

ASSEMBLY INSTRUCTIONS



Fine Furniture for every stage of life

TV STAND

ASSEMBLY INSTRUCTIONS

ASSEMBLY TIPS:

1. Remove hardware from box and sort by size.
2. Please check to see that all hardware and parts are present prior to start of assembly.
3. Please follow attached instructions in the same sequence as numbered to assure fast & easy assembly.



WARNING!

1. Don't attempt to repair or modify parts that are broken or defective. Please contact the store immediately.
2. This product is for home use only and not intended for commercial establishments.

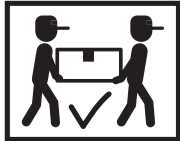

ASSEMBLY TIME

40 MINUTES

MAX TV SIZE : 78"

PARTS IDENTIFICATION

A LEFT SIDE PANEL

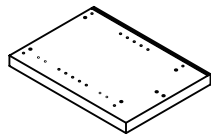

1 PC

B RIGHT SIDE PANEL

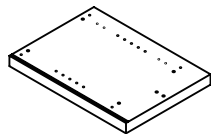

1 PC

C LEFT DIVIDE PANEL

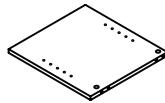

1 PC

D RIGHT DIVIDE PANEL

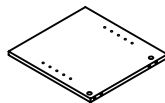

1 PC

E BOTTOM PANEL

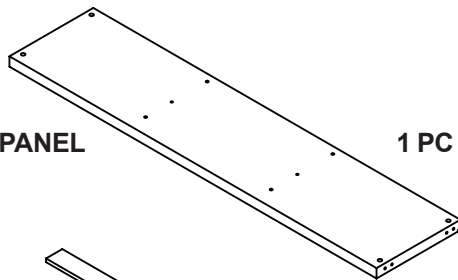

1 PC

F CROSS BRACE

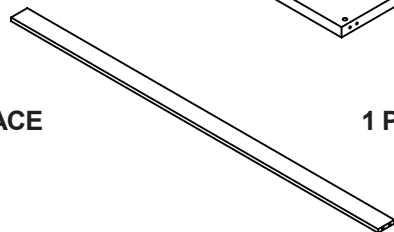

1 PC

G TOP PANEL

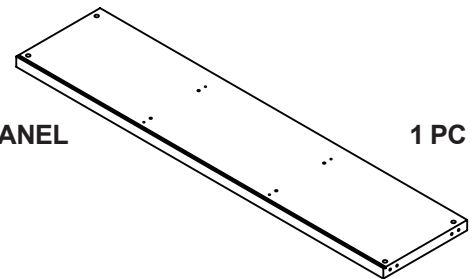

1 PC

H DOOR

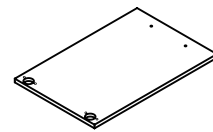

2 PCS

I ADJUSTABLE SHELF

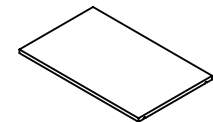

2 PCS

J MIDDLE ADJUSTABLE SHELF

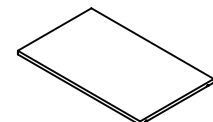

1 PC

K BACK PANEL

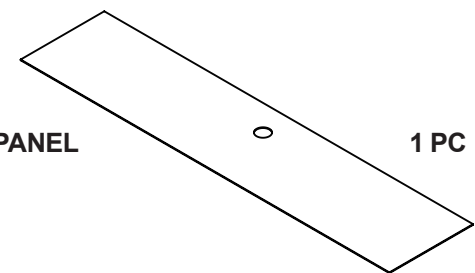









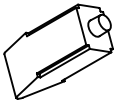
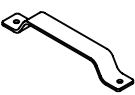
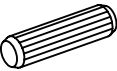

1 PC

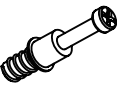
NOTE:

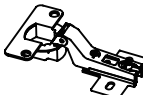
Phillips head screw driver is required in the assembly process; however, manufacturer does not provide this item.

HARDWARE IDENTIFICATION

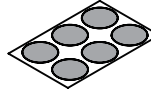
Z

NO	DESCRIPTION	FIGURE	Q'TY	NO	DESCRIPTION	FIGURE	Q'TY
1	GLUE 40g		1 PC	8	HANDLE		2 PCS
2	WOODEN DOWEL Ø 8x30mm		22 PCS	9	HANDLE BOLT M5x25mm		4 PCS
3	CAM BOLT Ø 7x35.5mm		12 PCS	10	NUT M5		4 PCS
4	CAM LOCK Ø 15x12mm		12 PCS	11	HINGE		4 PCS
5	SCREW Ø 4.5x42mm		4 PCS	12	HINGE SCREW Ø 4x15mm		16 PCS
6	PLASTIC FEET Ø 15mm		6 PCS	13	STICKER Ø 20mm		2 PCS
7	PIN Ø 4.9x8mm		12 PCS				

Z8,Z9,Z10,Z11 not included in blister packaging.

NOTE:

Phillips head screw driver is required in the assembly process; however, manufacturer does not provide this item.

STEP 1

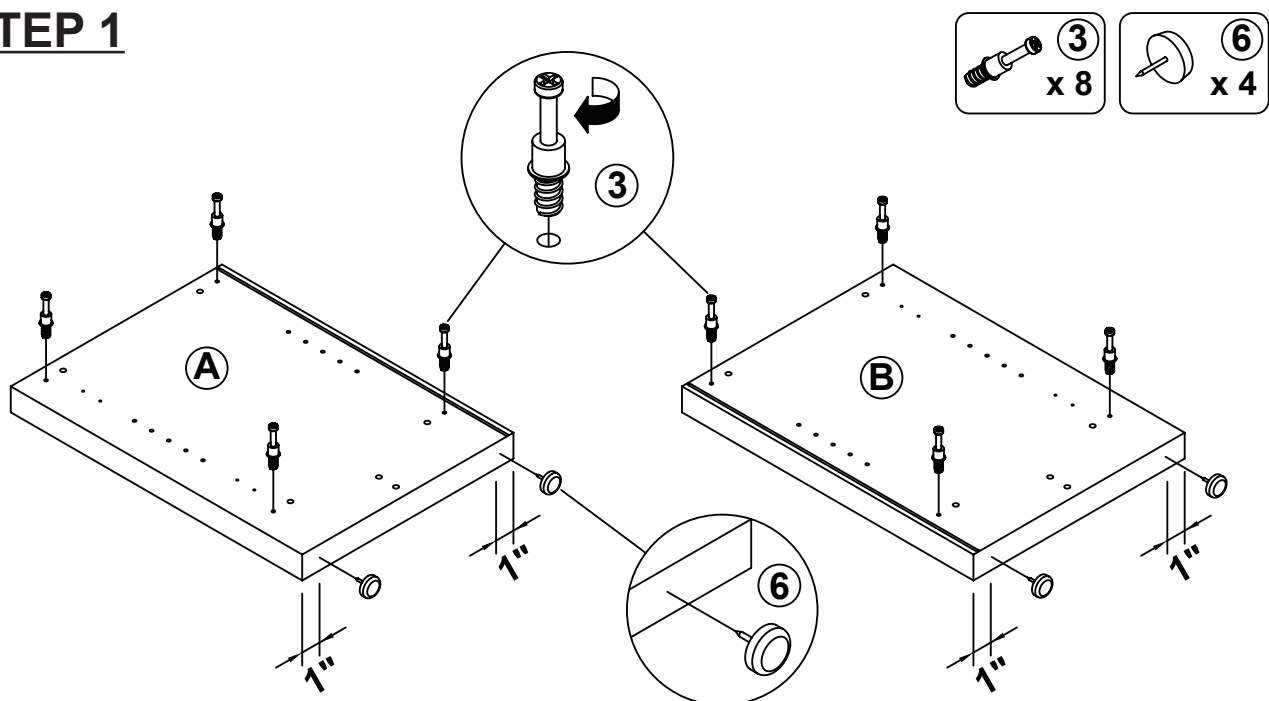

STEP 2

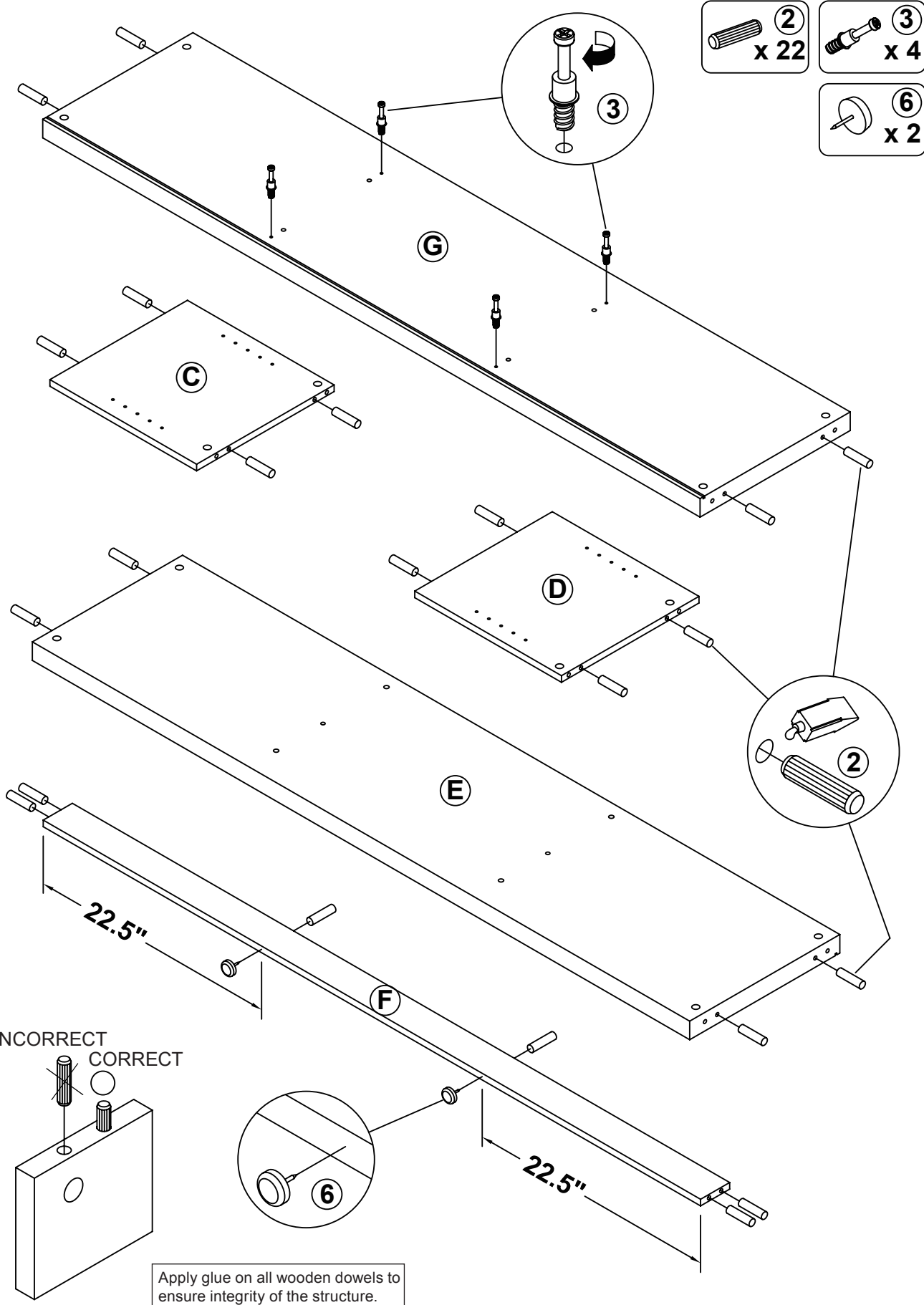

STEP 3

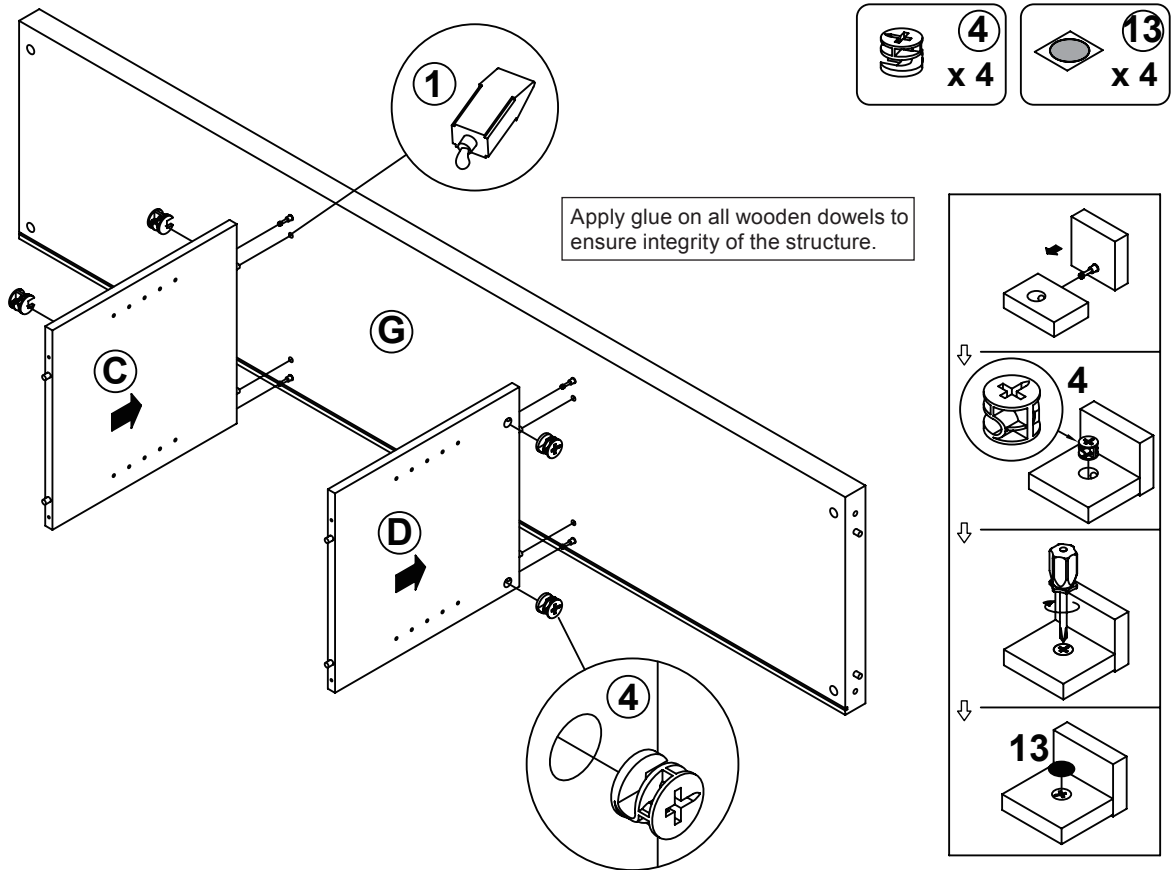

STEP 4

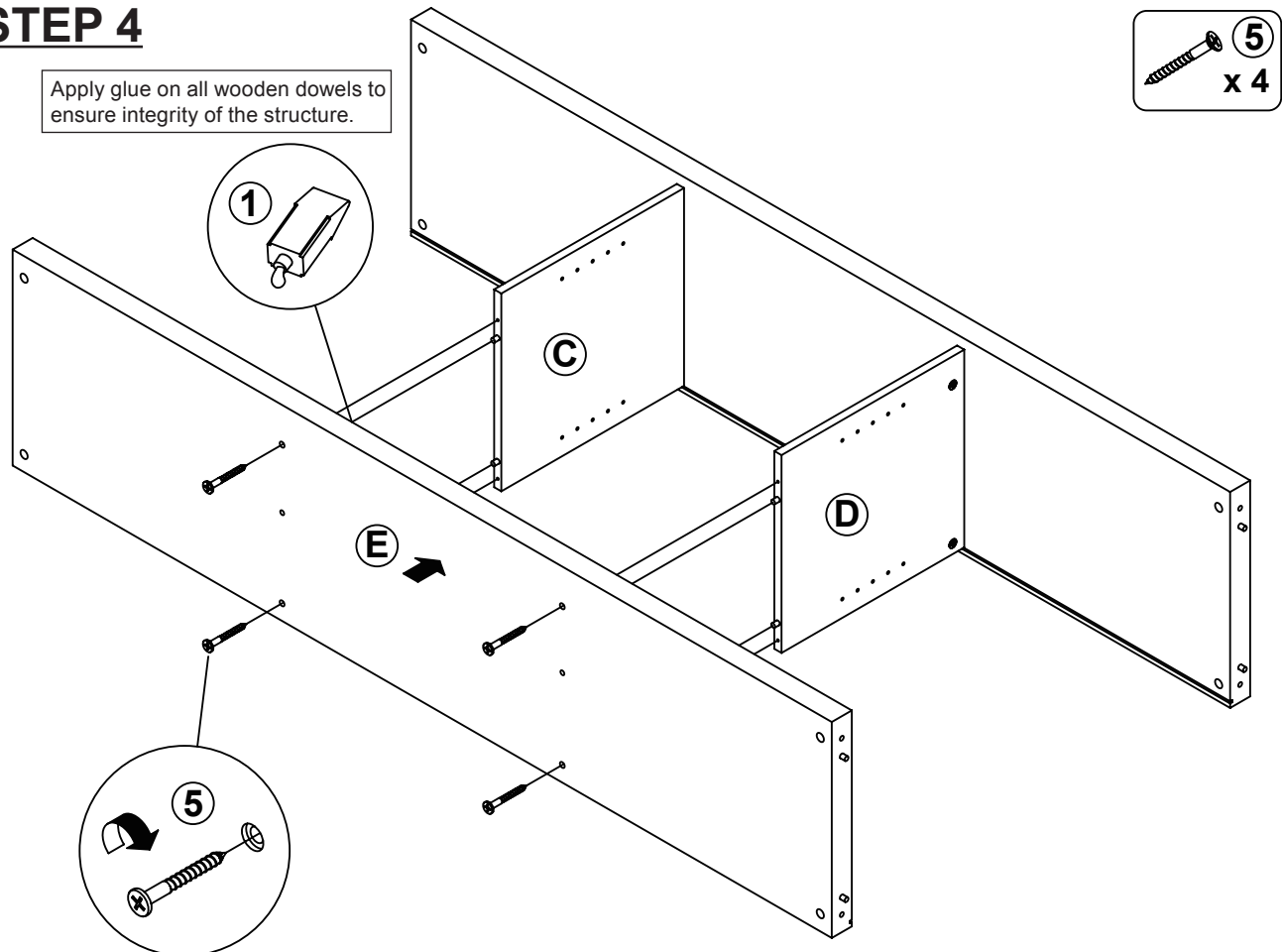

STEP 5

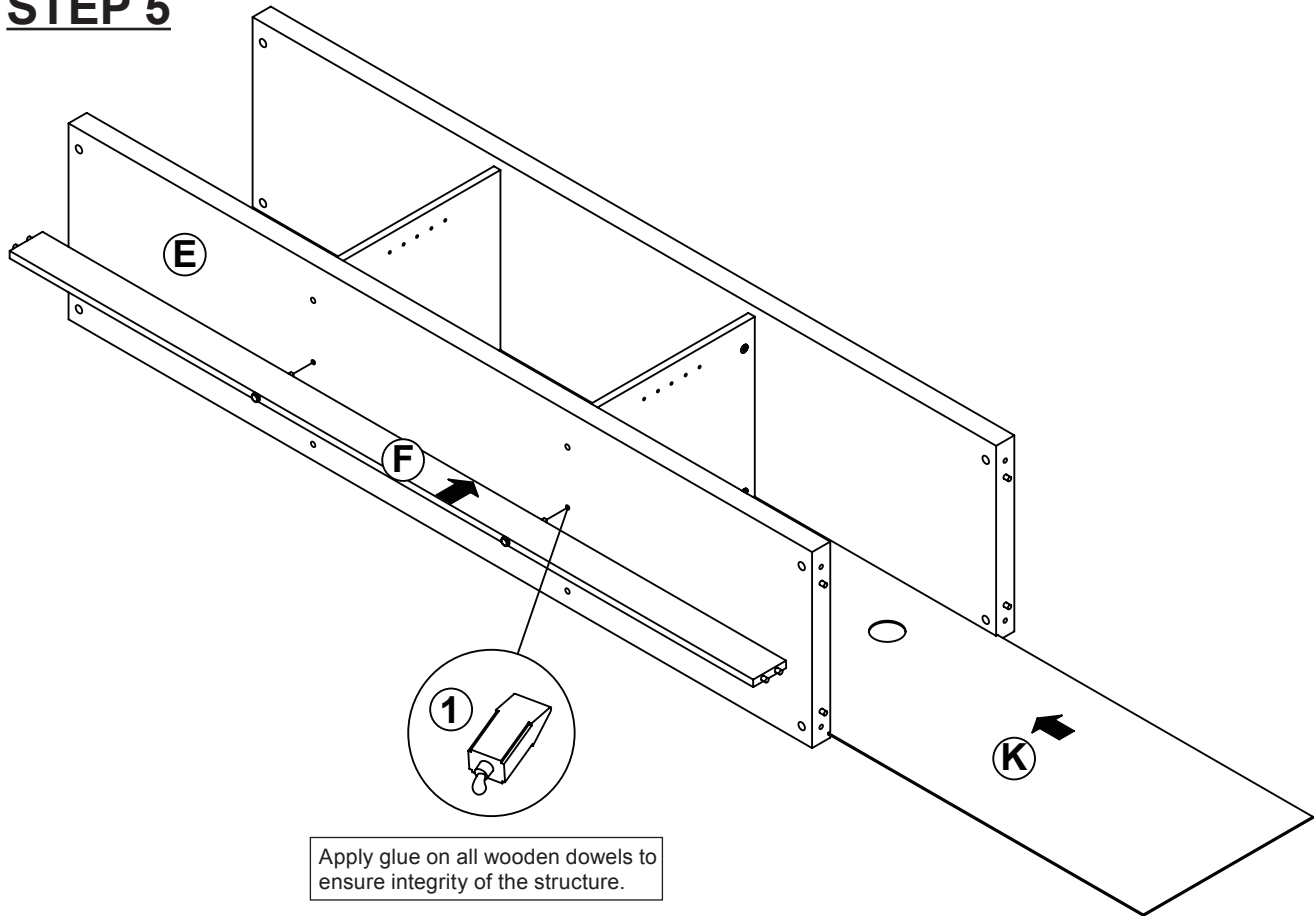

STEP 6

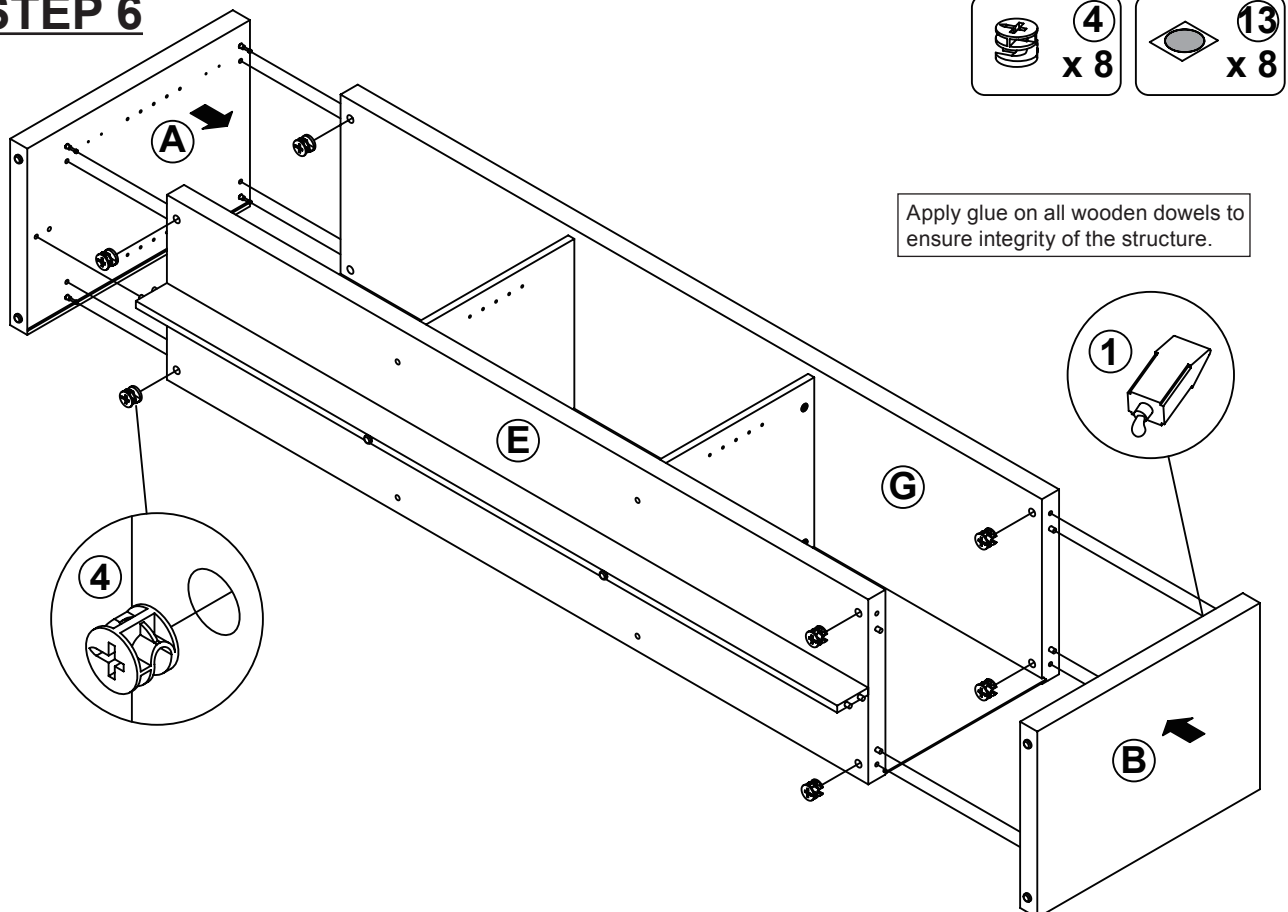

STEP 7

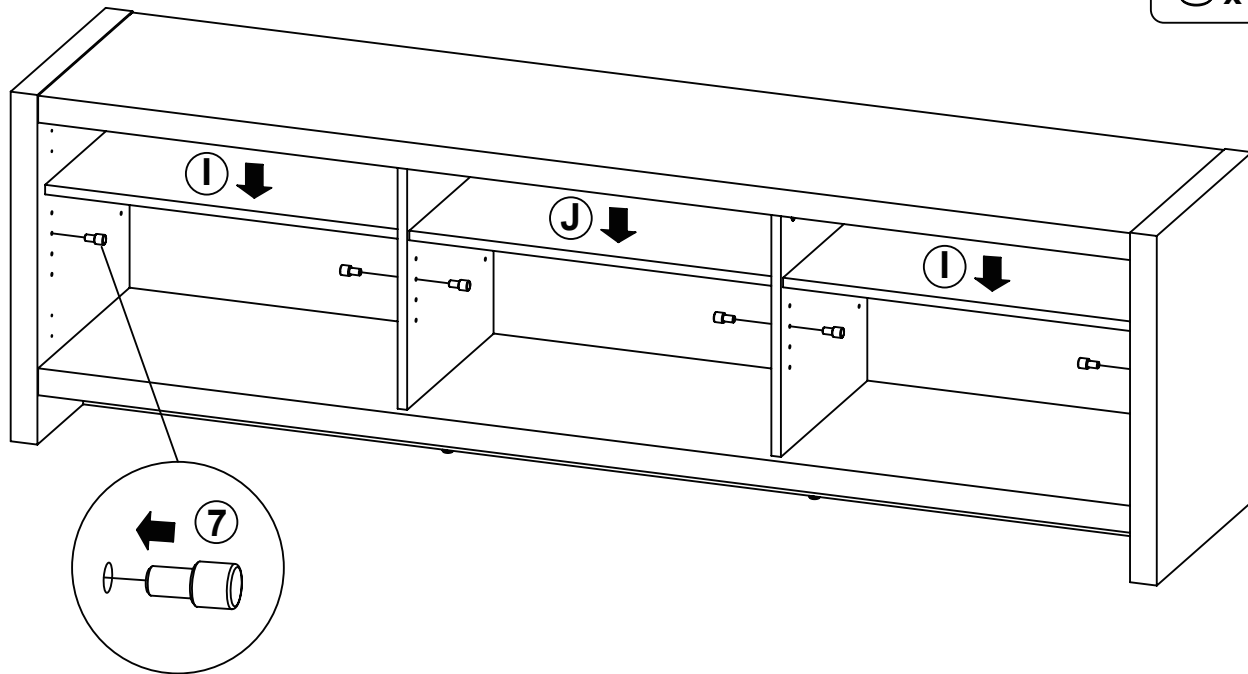
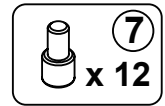

STEP 8

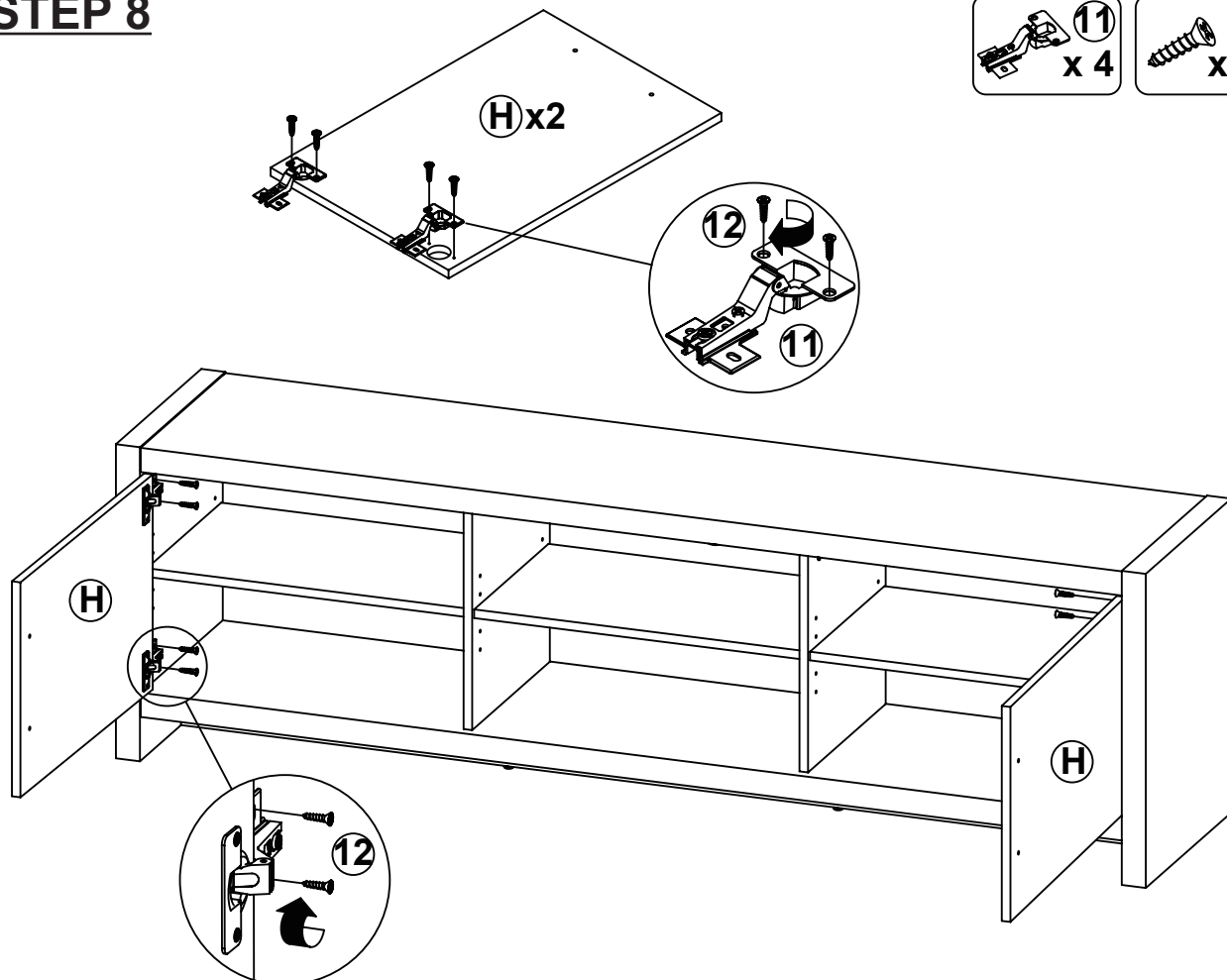
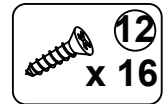
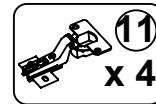

STEP 9

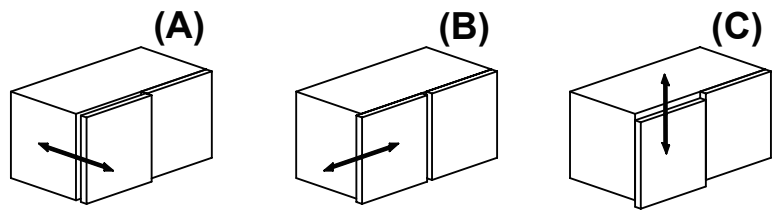
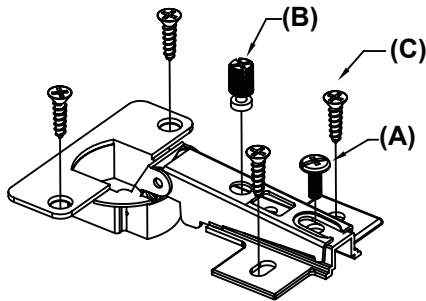
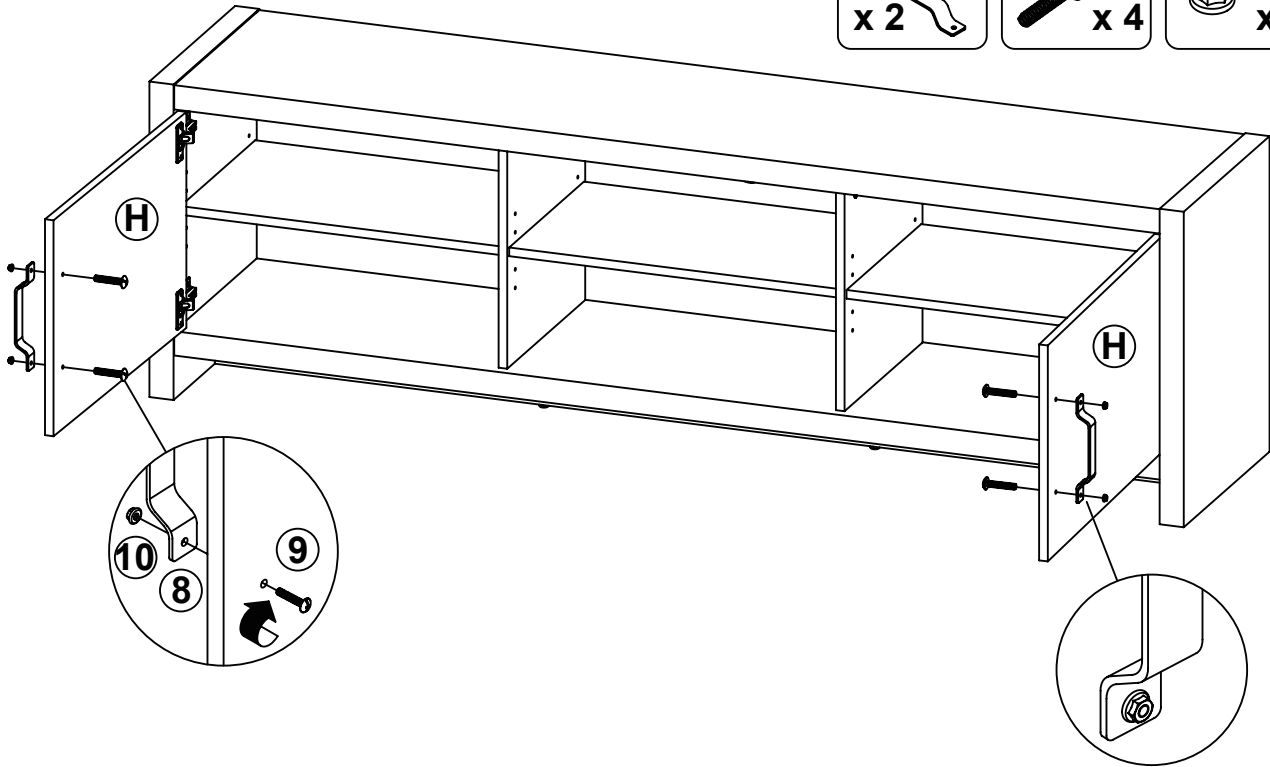
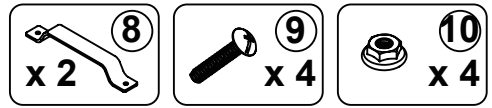

STEP 10

FINISH

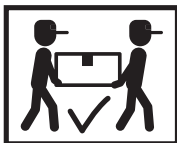
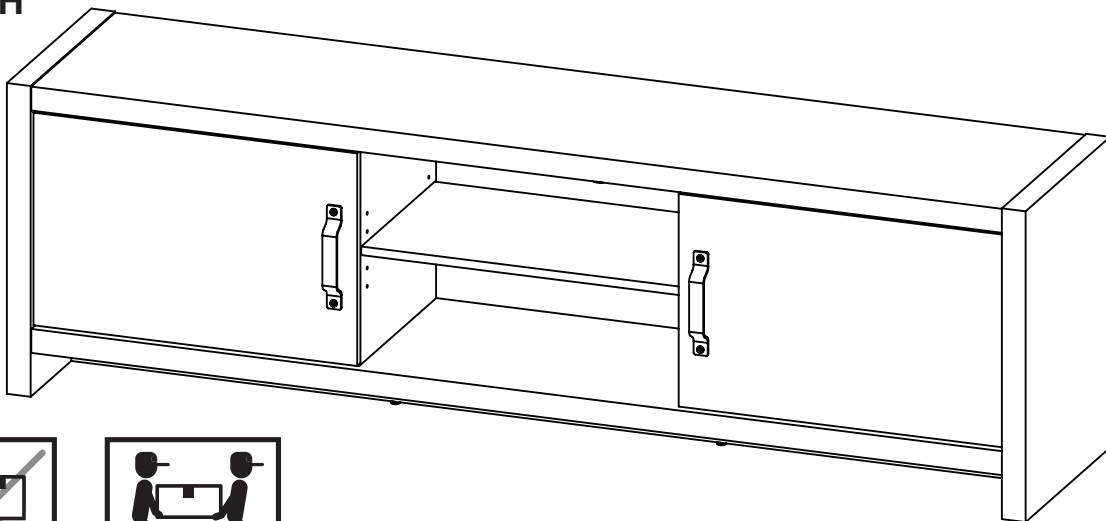

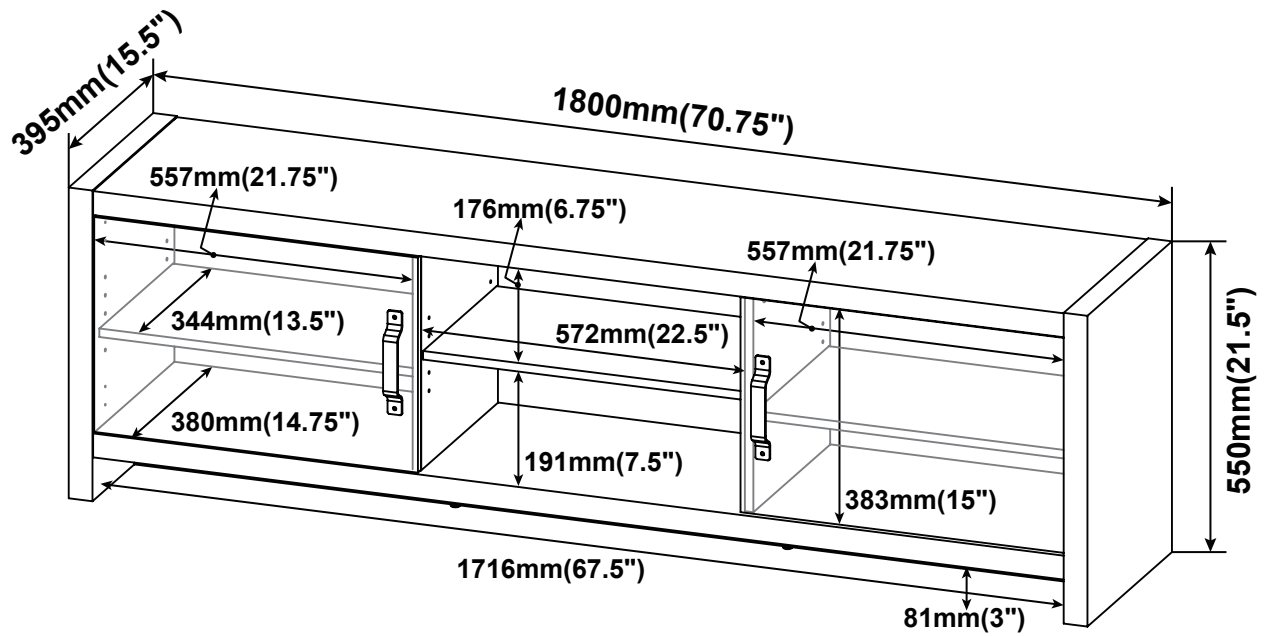
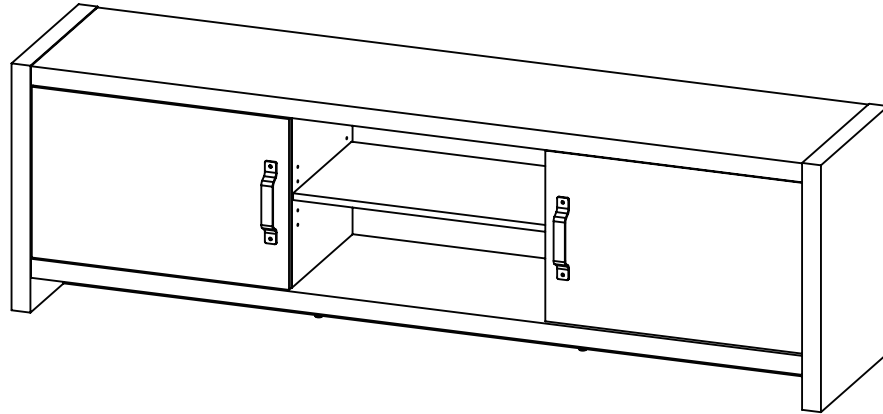

Note : Dimension tolerance $\pm 5\%$