

Important information to read
before starting the assembly.
Keep this information for future reference.

MODEL MODÈLE MODELO
26184-4
COLOR COULEUR COLOR
WO



WARNING

IMPACT OR CRUSHING HAZARD: If bed is not properly attached to the wall, it can suddenly fall, resulting in serious injury or death.

For wood or masonry wall structure, a qualified person must install the bed to the wall.

For all other types, a construction professional must install the bed to the wall in compliance with the codes and regulations in the province, state, or country where installed.

The choice of wall attachment screw depends on wall type. Use wall attachment screws suitable for your wall material.

Verify structural integrity of floor and wall prior to installation.

Do not open or use the bed if the bed cabinet moves while opening, or if you notice any other signs of loose or detaching screws.

Never remove wall attachment screws without first disassembling and removing the mattress frame and lift cylinders.

Qualified person must have the skills and tools necessary to locate wall studs, identify type of wall structure (wood, metal, masonry or other) and install screws correctly to wall structure. Skills and tools include electronic stud finder, drill motor and bits, screwdriver, and ability to correctly use these tools.

NOTICE

Bed frame maximum supporting weight: 1000 lb (455 kg).

Maximum mattress thickness: 10 in (25.5cm).

Mattress weight must be between: 60 lb (27 kg) and 90 lb (41 kg).

Minimum ceiling height:

Minimum holding force required for each fastener: 142 lb (630 N).

Not for use with folding mattress.

△ NOTE:

If there are parts missing from your order or if your product was damaged during shipping, PLEASE CONTACT US DIRECTLY.

△ NOTE :

S'il vous manque des pièces ou si votre meuble a été endommagé pendant le transport, VEUILLEZ NOUS CONTACTER DIRECTEMENT.

△ NOTA:

En caso de piezas faltantes o si su producto fue dañado durante el envío, POR FAVOR CONTACTENOS DIRECTAMENTE.

CONGRATS ON YOUR NEW PURCHASE! FÉLICITATIONS POUR VOTRE NOUVEL ACHAT!

We are thrilled to welcome you to the Bestar family. To ensure you get the most out of your new product, please follow the steps below.

Nous sommes ravis de vous accueillir dans la famille Bestar. Pour vous permettre de profiter au mieux de votre nouveau produit, veuillez suivre les étapes ci-dessous.

1



Activate Your Warranty Activez votre garantie

Register your product for warranty coverage by scanning the QR code or visiting bestar.com/warranty or bestar.ca/warranty. This ensures you receive the best support and service.

Enregistrez votre produit pour être couvert par la garantie en scannant le code QR ou en visitant le bestar.ca/fr/garantie. Vous pourrez ainsi bénéficier d'une assistance et d'un service de qualité.



Scan for Warranty Activation
Balayer pour activer la garantie
https://bestar.zendesk.com/hc/en-us/requests/new?ticket_form_id=23496338049300

2



How Did We Do? Comment avez-vous aimé votre expérience?

We value your feedback. Please take a moment to complete our survey by scanning the QR code. Your input helps us improve our products and services.

Votre avis nous intéresse. Nous vous invitons à prendre un moment pour répondre à notre sondage en scannant le code QR. Vos commentaires nous aident à améliorer nos produits et nos services.



Scan for NPS Survey
Balayer pour répondre au sondage
<https://www.surveymonkey.com/r/WLDTMC3>

3



Assembly Tips Conseils d'assemblage

To make assembly easier, follow our detailed instructions and refer to the video guides available on our website. Scan the QR code for assembly tips and tricks.

Pour faciliter l'assemblage, suivez nos instructions détaillées et consultez les guides vidéo disponibles sur notre site Web. Scannez le code QR pour obtenir des trucs et conseils d'assemblage.



Scan for Assembly Tips
Balayer pour les conseils d'assemblage
<https://bestar.zendesk.com/hc/en-us/articles/31744766678676-Videos>

4



Review & Renew Des avis pour l'avenir

Share your experience with others by leaving a review. As a thank you, we'll plant trees on your behalf, contributing to a greener planet. Scan the QR code to review.

Partagez votre expérience en laissant un avis. Pour vous remercier, nous planterons un arbre en votre nom pour un avenir plus vert. Scannez le code QR pour laisser un avis.



Scan to Leave a Review
Balayer pour laisser un avis
<https://esolutionsfurniture.com/review-and-renew/>

OUR TEAM IS HERE TO HELP.
NOTRE ÉQUIPE EST LÀ POUR VOUS AIDER.

If you have any questions or need assistance, our dedicated support team is ready to help. Visit our website for customer support or call our toll-free number.

Si vous avez des questions ou si vous avez besoin d'aide, notre équipe de soutien dévouée est prête à vous aider. Visitez notre site Web pour contacter notre service à la clientèle ou appelez notre numéro de téléphone sans frais.



Visit our website:
Visitez notre site Web :
bestar.com/support
bestar.ca/support
bestar.ca/fr/soutien



Call our toll-free number:
Appelez notre numéro sans frais :
1-800-950-4782

Important Notice / Note importante / Nota importante

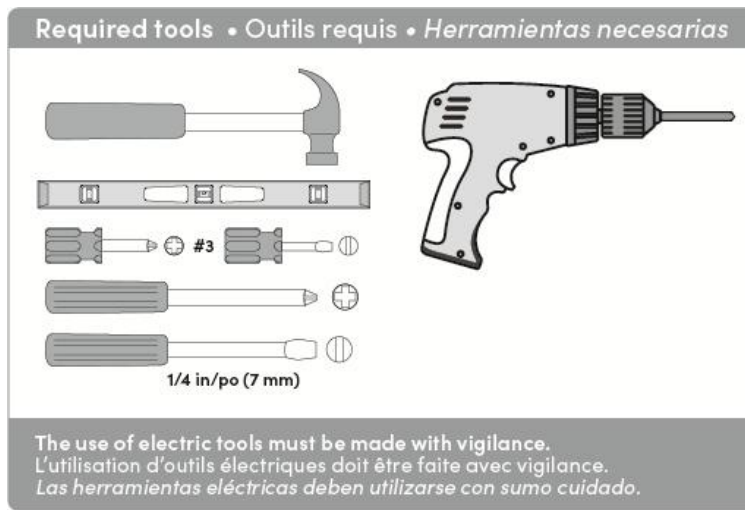
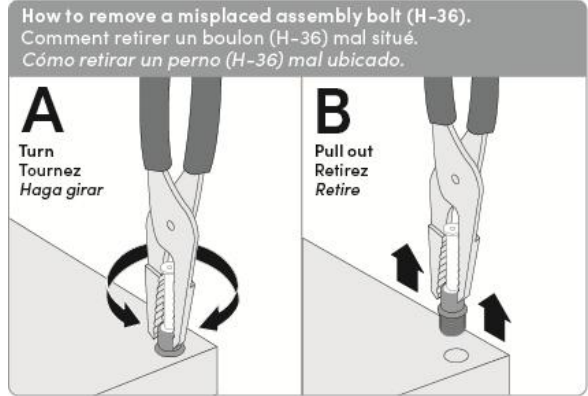
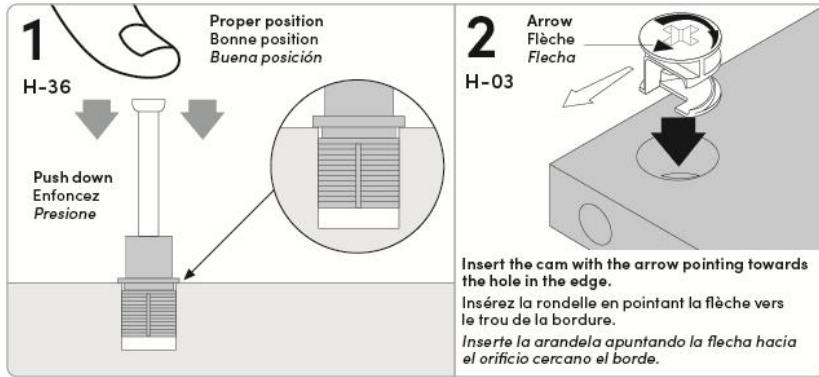

ASSEMBLY GUIDE
GUIDE D'ASSEMBLAGE
INSTRUCCIONES DE ENSAMBLAJE

bestar solutions
ameublement | furniture

MODEL / MODÈLE / MODELO
COLOR / COULEUR / COLOR
NO

△ NOTE:
If there are parts missing from your order or if your product was damaged during shipping, PLEASE CONTACT US DIRECTLY.

△ NOTE:
Si il vous manque des pièces ou si votre meuble a été endommagé pendant le transport, VEUILLEZ NOUS CONTACTER DIRECTEMENT.

△ NOTE:
En caso de piezas faltantes o si su producto fue dañado durante el envío, POR FAVOR CONTACTENOS DIRECTAMENTE.

KEEP MANUAL FOR FUTURE REFERENCE. | CONSERVEZ LE MANUEL POUR RÉFÉRENCE FUTURE. | GUARDE EL MANUAL PARA REFERENCIA FUTURA.

bestar solutions
ameublement | furniture

To better serve you!
pour mieux vous servir!

Model / Modèle: _____

Production Number
Numéro de production: _____

Customer Service
Service à la clientèle **1-800-950-4782**

Important Notice • Note importante • Nota importante

For future reference and to allow us to serve you better, please complete the self-adhesive sticker and apply it in an accessible space such as under shelf.

Pour que nous puissions mieux vous servir en cas besoin, veuillez compléter l'autocollant et l'apposer dans un endroit facilement accessible tel que dessous d'une tablette.

Para futuras referencias y un mejor servicio, por favor pegue la etiqueta adhesiva en un espacio accesible, Por ejemplo, la parte interior del estante.

Parts & Hardwares

Parts

Code	Qty	Code	Qty	Code	Qty	Code	Qty
30	1	60	1	71	1	83	1
31	1	61	1	80	1	85	1
41	1	70	1				

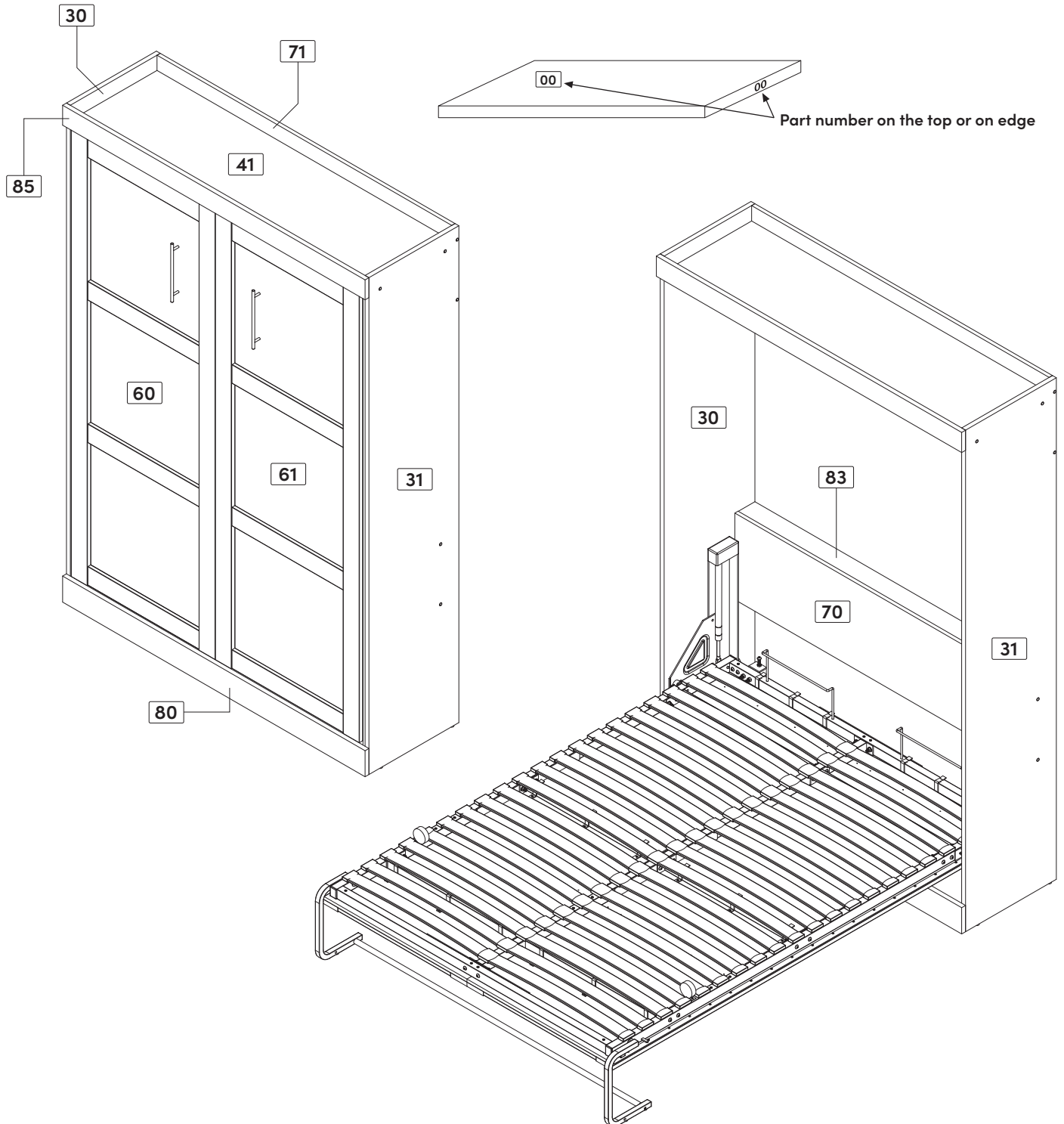











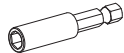

Have an assembly question or need a replacement part? Just call 1-800-950-4782, we are here to help.

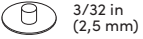
¿Tiene alguna pregunta sobre el montaje o necesita una pieza de repuesto? Simplemente llame al 1-800-950-4782, estamos aquí para ayudarle.

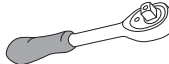

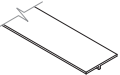









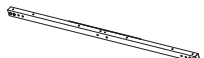





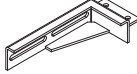
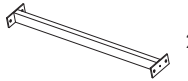

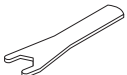
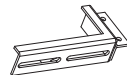
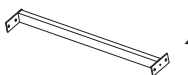

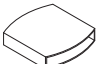

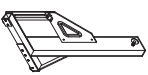

Vous avez une question concernant l'assemblage ou vous avez besoin d'une pièce de rechange? Appelez au 1-800-950-4782, nous sommes là pour vous aider.

Parts & Hardwares

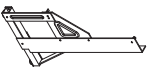
Hardwares in box 1

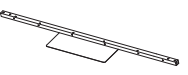
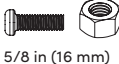
Code	Qty	Code	Qty	Code	Qty	Code	Qty
BT-1137	 1	GO-796	 14	H206515	 1	PA-844	 1 in (25 mm) 4
CA-100	 3/32 in (2,5 mm) 12	H-03	 4	H219091	 1	PO-959	 2
EX-7635	 83 in (2100 mm) 2	H-36	 4	H219092	 1/2 in 13 mm 1	LEG WARNING STICKER	1
FO-1136	 1						

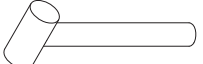
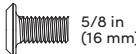
Hardwares in box 3 — Metal Mechanism

Code	Qty	Code	Qty	Code	Qty	Code	Qty
CA-7641	 2	KI-985-Q	 1	KI-7652-P	 2	KI-7652-A-4	 1
CR-7639	 3	KI-985-S	 42	KI-7652-S	 2	KI-7652-A-5	 1
KI-985-E	 2	KI-985-R	 42	KI-7652-W-2-1	 1	KI-7652-A-6	 2
KI-985-G	 1	KI-1115-P	 1	KI-7652-W-2-2	 1	KI-7652-A-7	 4
KI-985-H	 1	KI-7652-A-8	 21	KI-7652-X	 2 Not used for this model.	KI-7652-J	 2
KI-985-I	 1	KI-7652-C	 1	KI-7652-Y	 2	KI-7652-V	 1
KI-985-K	 18	KI-7652-D	 1	KI-7652-A-1	 1	KI-7652-W-1	 1
KI-985-L	 5/8 in (16 mm) 5	KI-7652-M	 32	KI-7652-A-2	 1	MA-1138	 1
KI-985-M	 5/8 in (16 mm) 18	KI-7652-O	 30	KI-7652-A-3	 1		

Important Notice

Group together all the hardware required for each step as the construction of your piece of furniture is progressing.





Have an assembly question or need a replacement part? Just call 1-800-950-4782, we are here to help.

¿Tiene alguna pregunta sobre el montaje o necesita una pieza de repuesto? Simplemente llame al 1-800-950-4782, estamos aquí para ayudarle.

Vous avez une question concernant l'assemblage ou vous avez besoin d'une pièce de rechange? Appelez au 1-800-950-4782, nous sommes là pour vous aider.

Parts & Hardwares

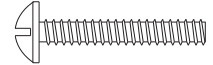
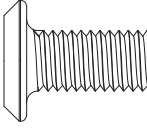
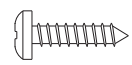
Real Size

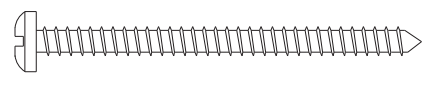
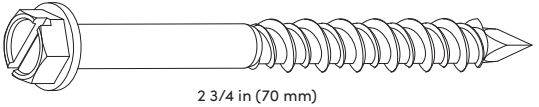
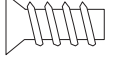
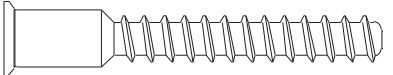
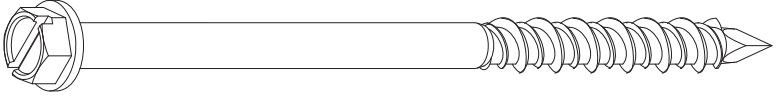
Code	Qty	Code	Qty
 KI-985-L  5/8 in (16 mm)	5	 VF-232 7/8 in (22 mm)	4
 KI-985-M 5/8 in (16 mm)	18	 VR-207 1/2 in (13 mm)	42
 KI-7652-M 2 5/32 in (55 mm)	32	 VR-215 2 in (51 mm)	8
 VB-1135 2 3/4 in (70 mm)	6	 3500-400350 1/2 in (13 mm)	42
 VC-204 2 in (50 mm)	15		
 VB-1134 4 in (102 mm)			8

Important Notice



BESTAR
Reinvent your space™

<http://bestar.ca>
<http://bestar.com>

26184-4

Important information to read before starting the assembly. Keep this information for future reference.

WARNING

Impact or Crushing Hazard: If bed is not properly attached to the wall, it can suddenly fall, resulting in serious injury or death.

- For wood, metal, or masonry wall structure, a qualified person must install the bed to the wall.
- For all other types, a construction professional must install the bed to the wall in compliance with the codes and regulations in the province, state, or country where installed.
- The choice of wall attachment screw depends on wall type. Use wall attachment screws suitable for your wall material.
- Verify structural integrity of floor and wall prior to installation.
- Do not open or use the bed if the bed cabinet moves while opening, or if you notice any other signs of loose or detaching screws.
- Never remove wall attachment screws without first disassembling and removing the mattress frame and fill cylinders.
- Qualified person must have the skills and tools necessary to locate wall studs, identify type of wall structure (wood, metal, masonry or other) and install screws correctly to wall structure. Skills and tools include electronic stud finder, drill motor and bits, screwdriver, and ability to correctly use these tools.

NOTICE

- Bed frame maximum supporting weight: 1000 lb (455 kg).
- Maximum mattress thickness: 10 in (25.4 cm).
- Mattress weight must be between: 60 lb (27 kg) and 90 lb (41 kg).
- Minimum ceiling height: 91.5 in (2.32 m).
- Minimum holding force required for each fastener: 142 lb (63.0 N).
- Not for use with folding mattress.

FOR ANY PROBLEM OR INFORMATION
1-888-BESTAR (1-888-823-7827)



To better serve you!
Pour mieux vous servir!

BESTAR

Model / Modèle: _____

Production Number
Numéro de production: _____

Customer Service
Service à la clientèle **1-888-823-7827**

For future reference and to allow us to serve you better, please complete the self-adhesive sticker and apply it in an accessible space such as the back of part 60.

Have an assembly question or need a replacement part? Just call 1-800-950-4782, we are here to help.

¿Tiene alguna pregunta sobre el montaje o necesita una pieza de repuesto? Simplemente llame al 1-800-950-4782, estamos aquí para ayudarle.

Vous avez une question concernant l'assemblage ou vous avez besoin d'une pièce de rechange? Appelez au 1-800-950-4782, nous sommes là pour vous aider.

Important Notice

Main hardware system. Installation steps.

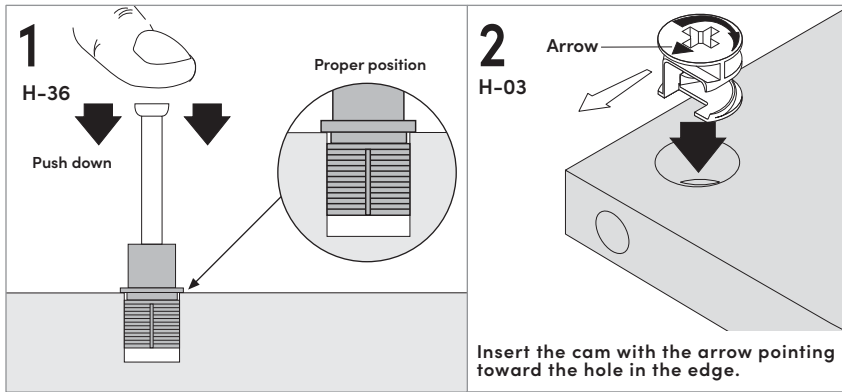

How to remove a misplaced assembly bolt (H-36).

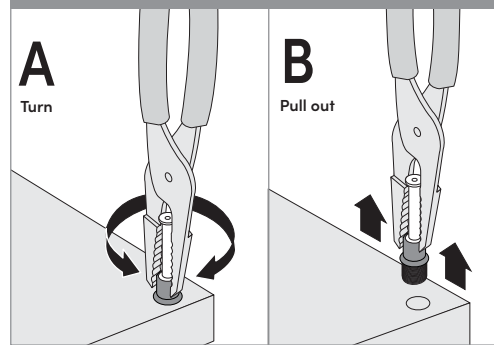

Main hardware system. Assembly steps.

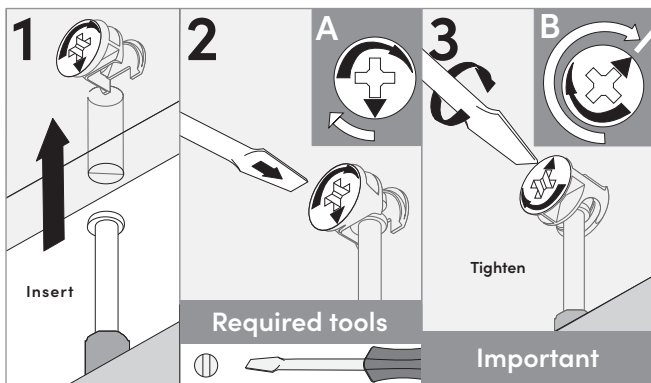

Make sure to properly tighten each cam to ensure furniture solidity. Otherwise, parts could be damaged or the user could be injured.

PA-844

Properly level your furniture using the adjustable legs.

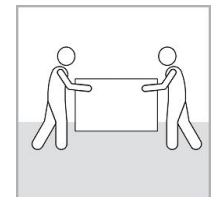
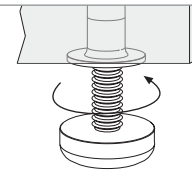

Team Lift
Esfuerzo de equipo
Effort d'équipe

When you have completed the assembly of your new furniture, install plastic caps

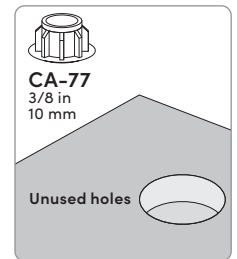
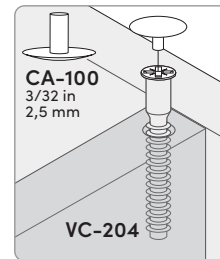
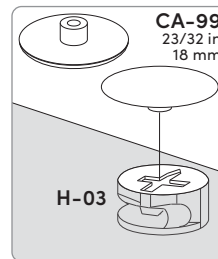

When you have completed the assembly of your new furniture, install self-adhesive caps on unused holes.



Required tools

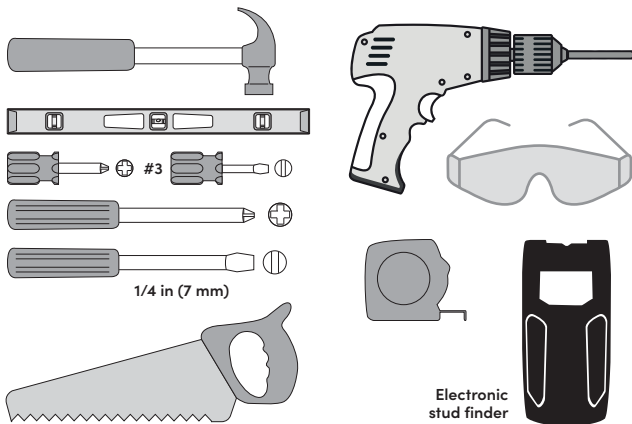

The use of power tools must be done with vigilance.

Easier with these tools

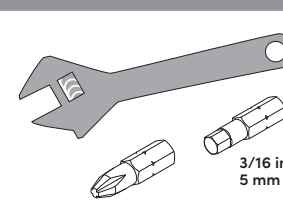



Have an assembly question or need a replacement part? Just call 1-800-950-4782, we are here to help.

¿Tiene alguna pregunta sobre el montaje o necesita una pieza de repuesto? Simplemente llame al 1-800-950-4782, estamos aquí para ayudarle.

Vous avez une question concernant l'assemblage ou vous avez besoin d'une pièce de rechange? Appelez au 1-800-950-4782, nous sommes là pour vous aider.

1 Hardware installation
Murphy bed

			 1 in (25 mm)
Code	GO-796	H-03	PA-844
Qty	x 14	x 4	x 4

NOTICE
Place boxes under parts during the assembly to avoid damage.

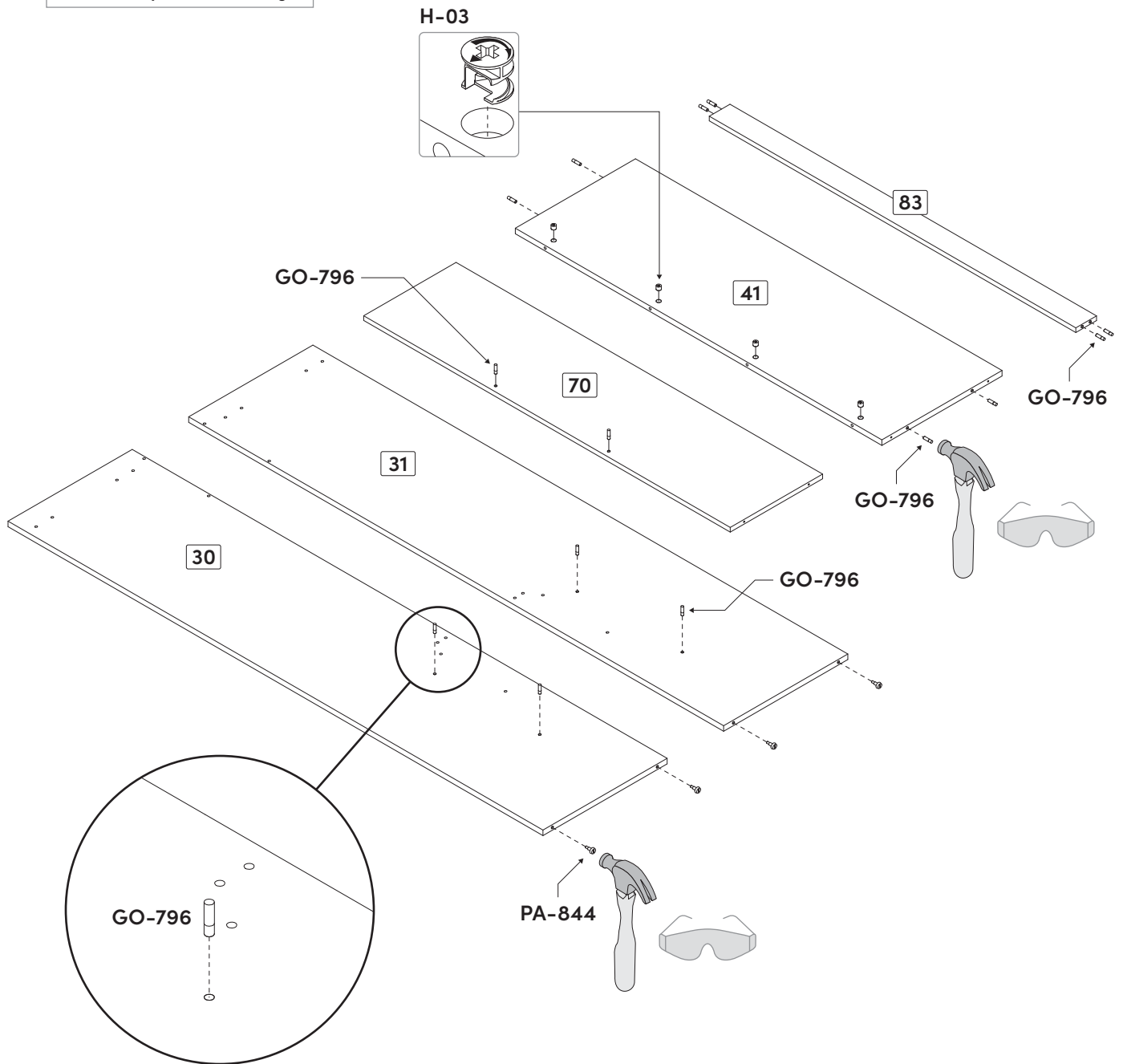

2 Hardware installation & assembly

Murphy bed

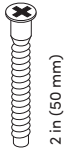

Code VC-204

Qty x 4

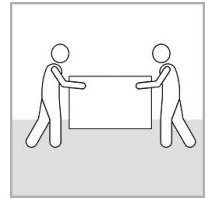

Team Lift
Esfuerzo de equipo
Effort d'équipe

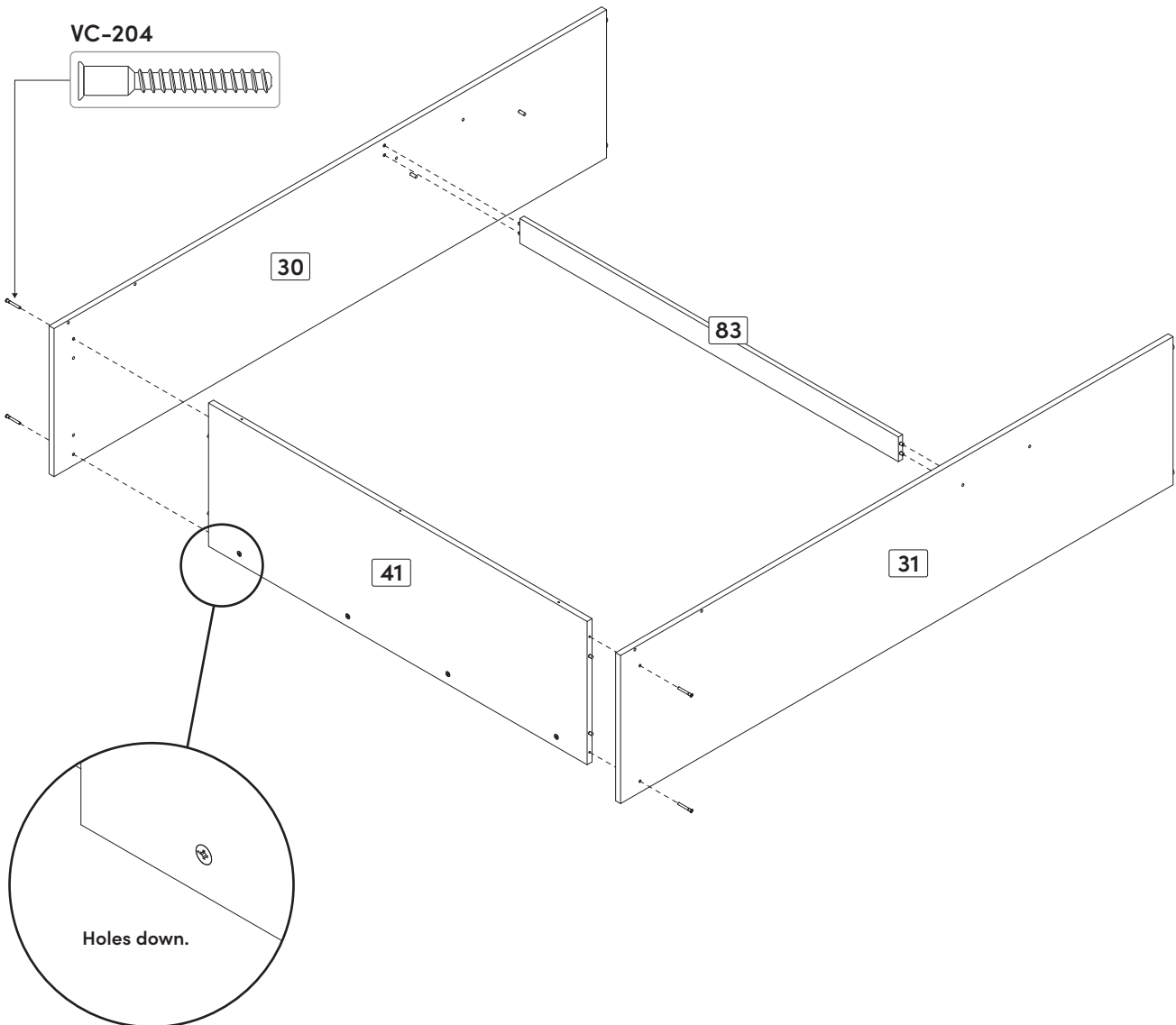

Have an assembly question or need a replacement part? Just call 1-800-950-4782, we are here to help.

¿Tiene alguna pregunta sobre el montaje o necesita una pieza de repuesto? Simplemente llame al 1-800-950-4782, estamos aquí para ayudarle.

Vous avez une question concernant l'assemblage ou vous avez besoin d'une pièce de rechange? Appelez au 1-800-950-4782, nous sommes là pour vous aider.

3

Hardware installation & assembly
Murphy bed

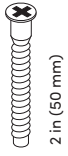

Code VC-204

Qty x 11

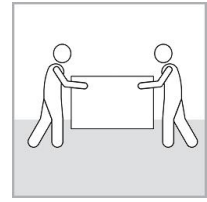

Team Lift
Esfuerzo de equipo
Effort d'équipe

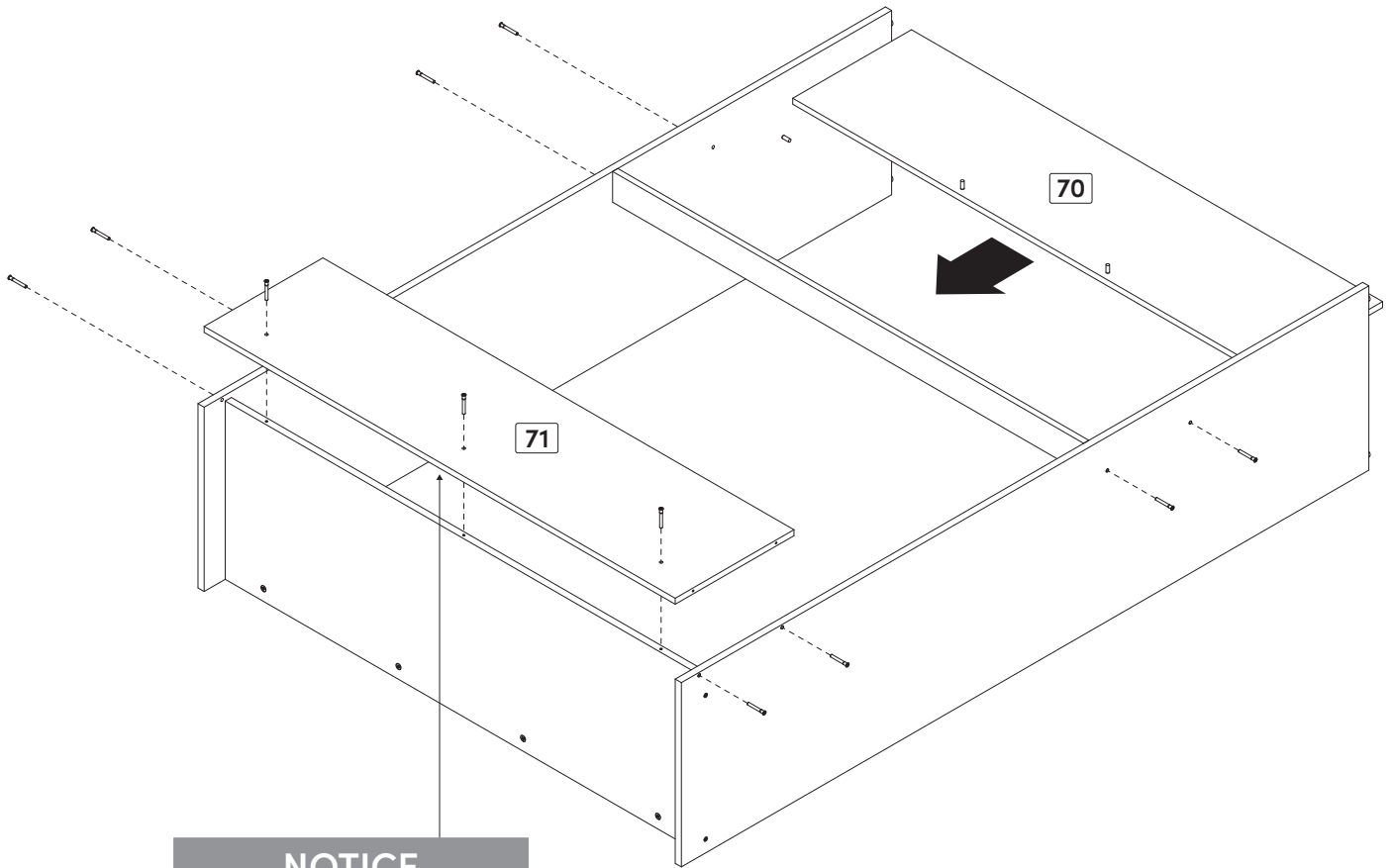

NOTICE

Label must face this way.
See next page for detailed view.

Have an assembly question or need a replacement part? Just call 1-800-950-4782, we are here to help.

¿Tiene alguna pregunta sobre el montaje o necesita una pieza de repuesto? Simplemente llame al 1-800-950-4782, estamos aquí para ayudarle.

Vous avez une question concernant l'assemblage ou vous avez besoin d'une pièce de rechange? Appelez au 1-800-950-4782, nous sommes là pour vous aider.

4 Assembly Murphy bed

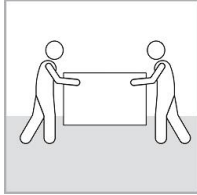

Team Lift
Esfuerzo de equipo
Effort d'équipe

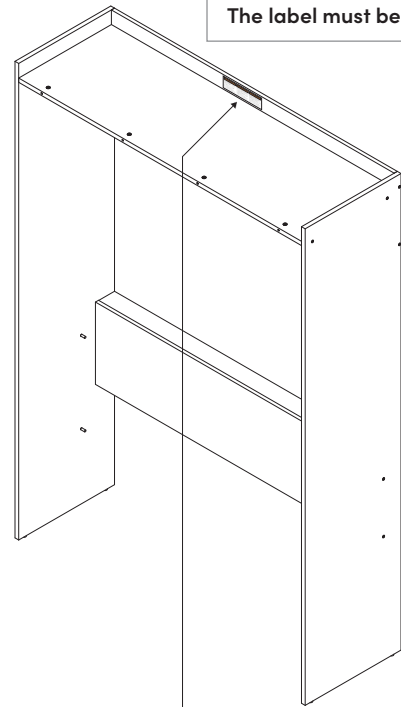
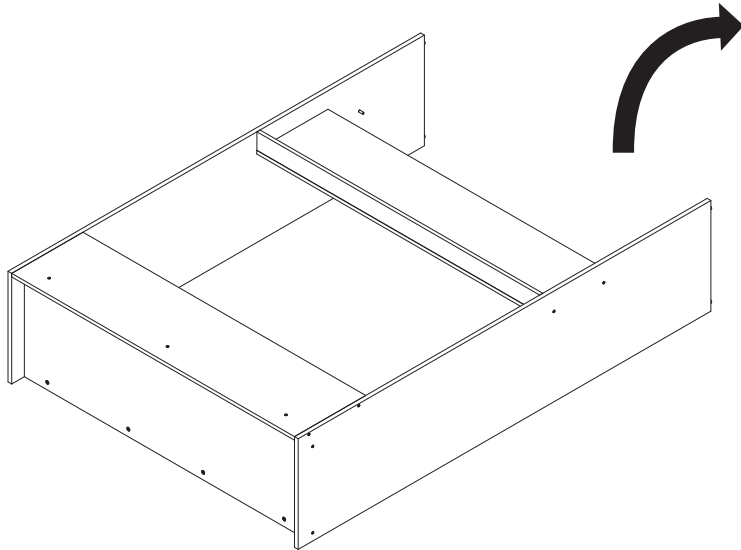

NOTICE

The label must be visible.

122-00098-0



WARNING

IMPACT or CRUSHING HAZARD: If wall bed mechanism is not properly attached to the floor and wall, it can suddenly rotate, resulting in serious injury or death.

- For wood and masonry floor and wall structure, a qualified person must install the wall bed mechanism.
- For all other type of floor or wall structure, a professional must install the wall bed mechanism.
- The choice of attachment screws depends on floor and wall type. Use attachment screws suitable for your floor and wall material.
- Verify structural integrity of floor and wall prior to installation.
- NEVER use hollow wall anchors.
- ALWAYS use 12 screws for floor and wall attachment.
- NEVER remove floor and wall attachment screws without first disassembling and removing the lift cylinders and mattress frame.
- Only a professional or qualified person should disassemble this wall bed.
- Disassemble product in reverse order of initial assembly.
- Refer to owner's manual or download manual at bestar.ca or bestar.com



AVERTISSEMENT

RISQUE DE CHOC ou D'ÉCRASEMENT : Si le mécanisme du lit escamotable n'est pas correctement fixé au plancher et au mur, il peut subitement pivoter, entraînant des blessures graves ou la mort.

- Pour les structures de murs et de planchers en bois et en maçonnerie, une personne qualifiée doit installer le mécanisme du lit escamotable.
- Pour tout autre type de structure de mur et de plancher, un professionnel doit installer le mécanisme du lit escamotable.
- Le choix de vis de fixation dépend du type de plancher et de mur. Utilisez des vis de fixation adaptées au matériau de votre plancher et de votre mur.
- Vérifiez l'intégrité structurelle du plancher et du mur avant l'installation.
- N'utilisez JAMAIS de chevilles pour cloison sèche.
- Utilisez TOUJOURS 12 vis pour la fixation au sol et au mur.
- Ne retirez JAMAIS les vis de fixation au sol et au mur sans avoir préalablement démonté et retiré les vérins de levage et le cadre du matelas.
- Seul un professionnel ou une personne qualifiée devrait démonter ce lit escamotable.
- Consultez le manuel du propriétaire ou téléchargez le manuel sur bestar.ca.



ADVERTENCIA

PELIGRO DE IMPACTO o APLASTAMIENTO: Si el mecanismo de la cama abatible no está bien fijado al suelo y a la pared, puede girar repentinamente y provocar lesiones graves o la muerte.

- Para suelos y paredes de madera y mampostería, una persona cualificada debe instalar el mecanismo de la cama mural.
- Para cualquier otro tipo de estructura de suelo o pared, un profesional debe instalar el mecanismo de la cama abatible.
- La elección de los tornillos de fijación depende del tipo de suelo y pared. Utilice tornillos de fijación adecuados para el material del suelo y la pared.
- Verifique la integridad estructural del suelo y la pared antes de la instalación.
- Nunca utilice anclajes de pared huecos.
- Utilice siempre 12 tornillos para la fijación al suelo y a la pared.
- Nunca retire los tornillos de fijación al suelo y a la pared sin antes desmontar y retirar los cilindros de elevación y el armazón del colchón.
- Sólo un profesional o persona cualificada debe desmontar esta cama abatible.
- Desmante el producto en el orden inverso al del montaje inicial.
- Consulte el manual del propietario o descargue el manual en bestar.ca o bestar.com.

122-00098-0

Have an assembly question or need a replacement part? Just call 1-800-950-4782, we are here to help.

¿Tiene alguna pregunta sobre el montaje o necesita una pieza de repuesto? Simplemente llame al 1-800-950-4782, estamos aquí para ayudarle.

Vous avez une question concernant l'assemblage ou vous avez besoin d'une pièce de rechange? Appelez au 1-800-950-4782, nous sommes là pour vous aider.

WALL ANCHORING REQUIREMENTS & INSTALLATION RECOMMENDATIONS

Important information to read before starting the assembly.
Keep this information for future reference.



WARNING

IMPACT OR CRUSHING HAZARD: If bed is not properly attached to the wall, it can suddenly fall, resulting in serious injury or death.

- For wood or masonry wall structure, a qualified person must install the bed to the wall.
- For all other types, a construction professional must install the bed to the wall in compliance with the codes and regulations in the province, state, or country where installed.
- The choice of wall attachment screw depends on wall type. Use wall attachment screws suitable for your wall material.
- Verify structural integrity of floor and wall prior to installation.
- Do not open or use the bed if the bed cabinet moves while opening, or if you notice any other signs of loose or detaching screws.
- Never remove wall attachment screws without first disassembling and removing the mattress frame and lift cylinders.
- Qualified person must have the skills and tools necessary to locate wall studs, identify type of wall structure (wood, metal, masonry or other) and install screws correctly to wall structure. Skills and tools include electronic stud finder, drill motor and bits, screwdriver, and ability to correctly use these tools.



WARNING

IMPACT OR CRUSHING HAZARD: If bed is not properly attached to the wall, it can suddenly fall, resulting in serious injury or death.

- NEVER use hollow-wall or drywall anchors.
- NEVER attach wall bed directly to drywall, sheetrock, gypsum, or other wall board.
- ALWAYS attach wall bed to wood stud, steel stud or masonry wall structure.
- ALWAYS use two (2) screws for wall attachment.

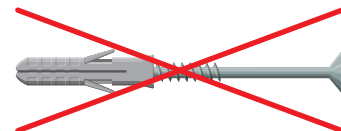

Have an assembly question or need a replacement part? Just call 1-800-950-4782, we are here to help.

¿Tiene alguna pregunta sobre el montaje o necesita una pieza de repuesto? Simplemente llame al 1-800-950-4782, estamos aquí para ayudarle.

Vous avez une question concernant l'assemblage ou vous avez besoin d'une pièce de rechange? Appelez au 1-800-950-4782, nous sommes là pour vous aider.

WALL ANCHORING INSTRUCTIONS

ATTACHING THE CABINET TO THE WALL STRUCTURE

INSTALLATION RECOMMENDATIONS

1

Locate stud centerlines using electronic stud finder. Use pencil to mark stud centerlines above the upper back of wall bed.

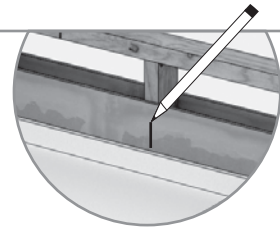

2

Drill a 1/8 in or 3 mm pilot hole into the wall stud to determine the type of wall structure present.

3

WOOD found behind the wall board?

- Use a 1/8 in drill for the pilot hole on back panel.
- Use the wood stud mounting approach with the six #10 x 4 in VB-1134 screws provided.

VB-1134
4 in (102 mm)

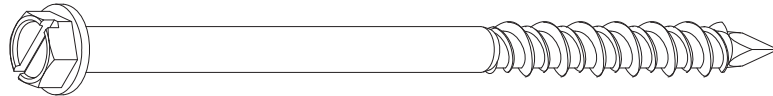

4

CONCRETE found behind the wall board?

- Use a 5/32 in masonry drill for the pilot hole on back panel and for the wall.
- Use the masonry wall structure mounting approach with the six #10 x 4 in VB-1134 screws provided.

VB-1134
4 in (102 mm)



122-00099-0



WARNING

RISK OF SERIOUS INJURY or DEATH: improper assembly, use, or loading can lead to product instability, tip-over, or collapse.

- Assemble following all instructions using all indicated parts and hardware.
- Attach cabinet to the wall (wood stud, metal stud, or masonry) structure.
- Verify product is stable on its own.
- Do not allow children to stand, climb, or hang on furniture.



AVERTISSEMENT

RISQUE DE MORT ou DE BLESSURES GRAVES: Un assemblage, une utilisation ou un chargement inappropriés peuvent entraîner l'instabilité, le renversement ou l'effondrement du produit.

- Complétez l'assemblage en suivant toutes les instructions et en utilisant toutes les pièces et le matériel indiqués.
- Fixez le caisson à la structure du mur (montants de bois, montants de métal ou maçonnerie).
- Vérifiez que le produit est stable.
- Ne laissez pas des enfants grimper et se tenir debout sur le meuble, ou s'y accrocher.



ADVERTENCIA

RIESGO DE LESIONES GRAVES o DE MUERTE: Un montaje, uso o carga inadecuados pueden provocar la inestabilidad, el vuelco o el colapso del producto.

- Ensamble siguiendo todas las instrucciones y utilizando todas las piezas y herrajes indicados.
- Fije el armario a la estructura de la pared (montante de madera, montante metálico o mampostería).
- Compruebe que el producto es estable por sí mismo.
- No permita que los niños se pongan de pie, trepen o se cuelguen de los muebles.

122-00099-0

Have an assembly question or need a replacement part? Just call 1-800-950-4782, we are here to help.

¿Tiene alguna pregunta sobre el montaje o necesita una pieza de repuesto? Simplemente llame al 1-800-950-4782, estamos aquí para ayudarle.

Vous avez une question concernant l'assemblage ou vous avez besoin d'une pièce de rechange? Appelez au 1-800-950-4782, nous sommes là pour vous aider.

WALL ANCHORING INSTRUCTIONS WOOD STUDS

INSTALLATION RECOMMENDATIONS

- 1** Determine the position of the bed in the room.

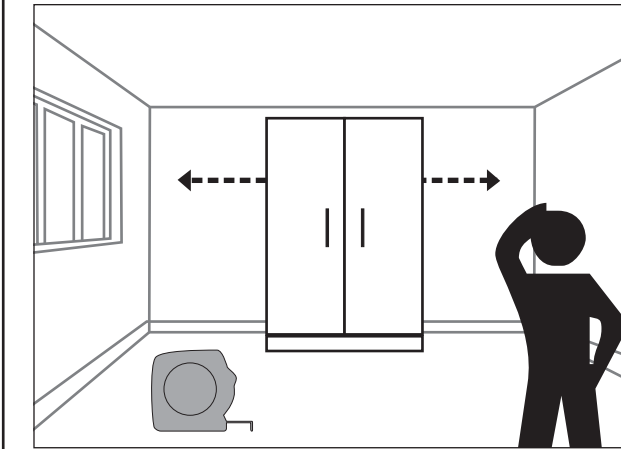

- 2** Move the bed if necessary, then remove the floor trim completely.

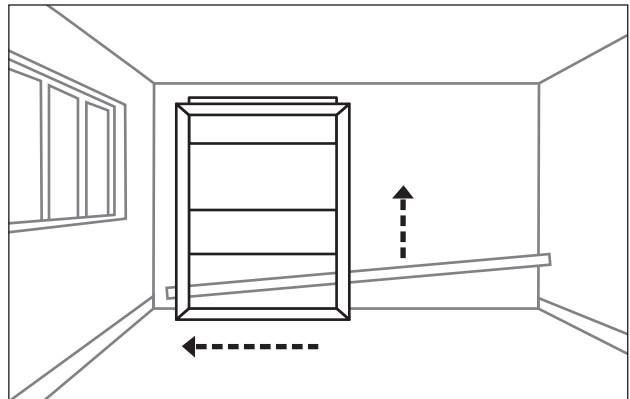

- 3** Locate and mark the positioning of 2 studs using a stud finder.

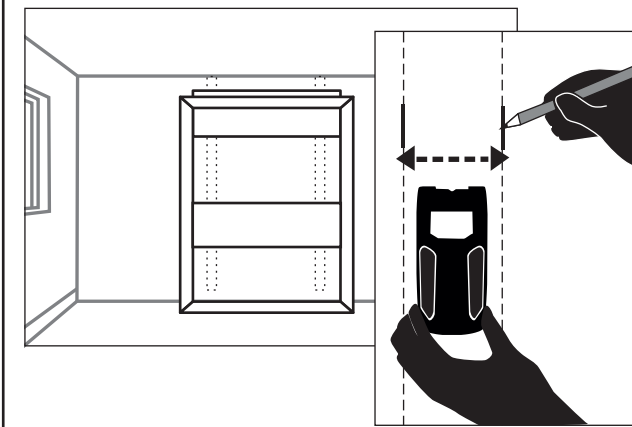

- 4** Put the bed back in its place. Level by adjusting the legs PA-844 previously installed. If you install the bed on a carpet, you must raise the bed by an extra 3/8 in (10 mm).

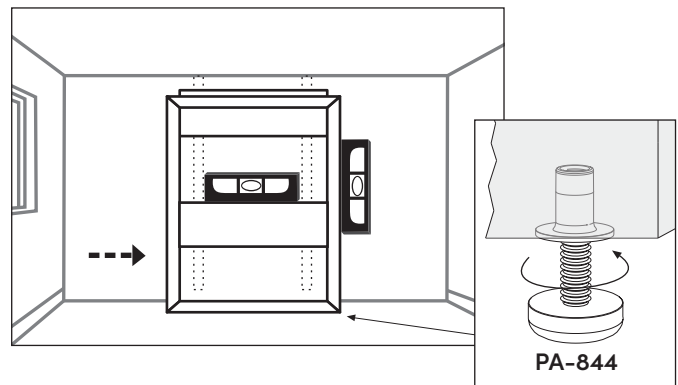

- 5** Line up back panel on the wall and mark the middle of the studs on the back panel, then pre-drill back panel with 1 pilot hole of 1/8 in (3 mm) diameter per stud (2 holes in total). DO NOT DRILL HOLES INTO THE WOOD STUDS.

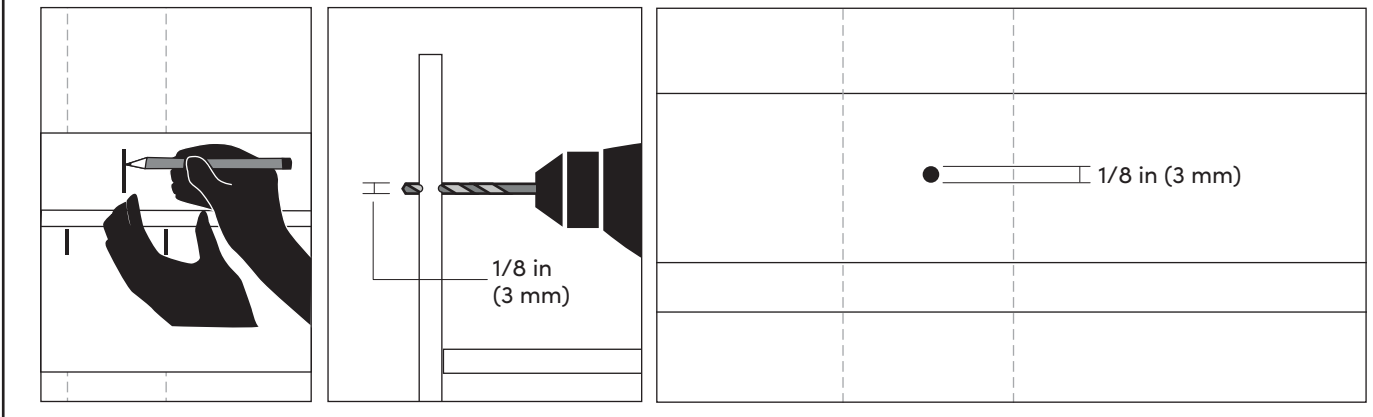

Have an assembly question or need a replacement part? Just call 1-800-950-4782, we are here to help.

¿Tiene alguna pregunta sobre el montaje o necesita una pieza de repuesto? Simplemente llame al 1-800-950-4782, estamos aquí para ayudarle.

Vous avez une question concernant l'assemblage ou vous avez besoin d'une pièce de rechange? Appelez au 1-800-950-4782, nous sommes là pour vous aider.

WALL ANCHORING INSTRUCTIONS WOOD STUDS

INSTALLATION RECOMMENDATIONS

- 6** Put the VB-1134 screws through the holes of back panel and screw into the center of the studs until the plywood is tight against the wall.
USE AN ELECTRIC SCREWDRIVER WITH AN ADJUSTABLE TENSION CLUTCH THAT HELPS PREVENT OVER-TIGHTENING AND STRIPPING.

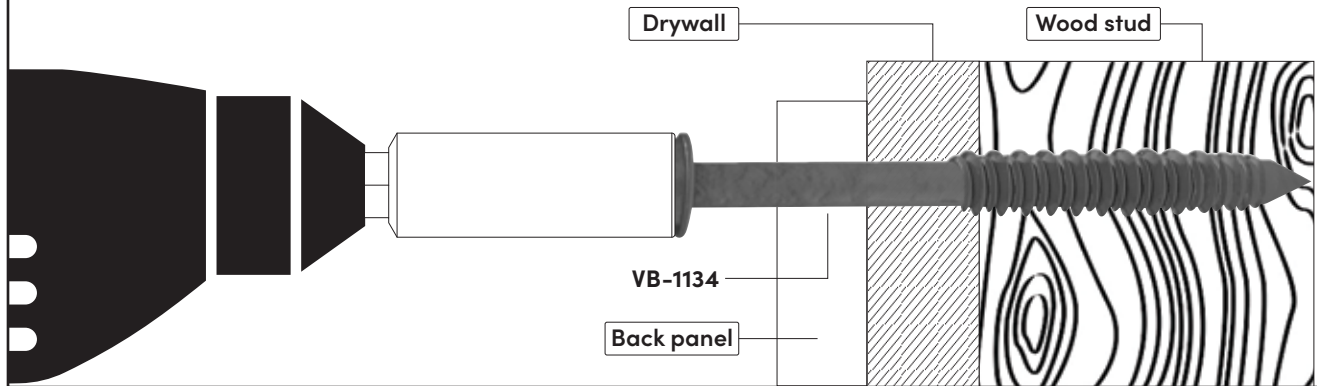

Have an assembly question or need a replacement part? Just call 1-800-950-4782, we are here to help.

¿Tiene alguna pregunta sobre el montaje o necesita una pieza de repuesto? Simplemente llame al 1-800-950-4782, estamos aquí para ayudarle.

Vous avez une question concernant l'assemblage ou vous avez besoin d'une pièce de rechange? Appelez au 1-800-950-4782, nous sommes là pour vous aider.

WALL ANCHORING INSTRUCTIONS MASONRY

INSTALLATION RECOMMENDATIONS

- 1** Determine and mark the position of the bed in the room.

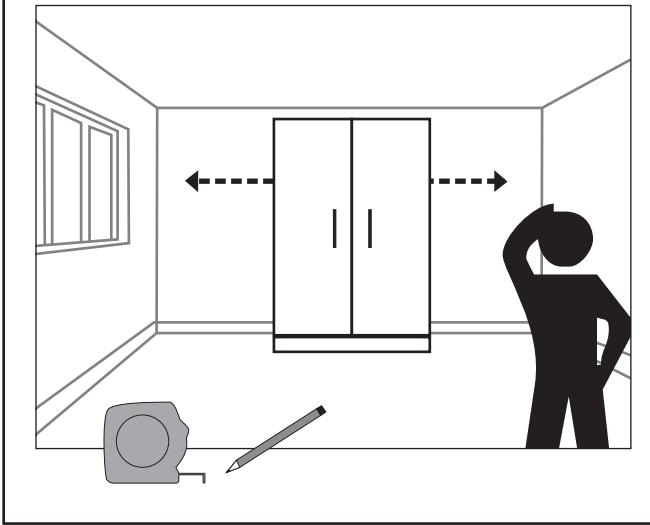

- 2** Move the bed if necessary, then remove the floor trim completely.

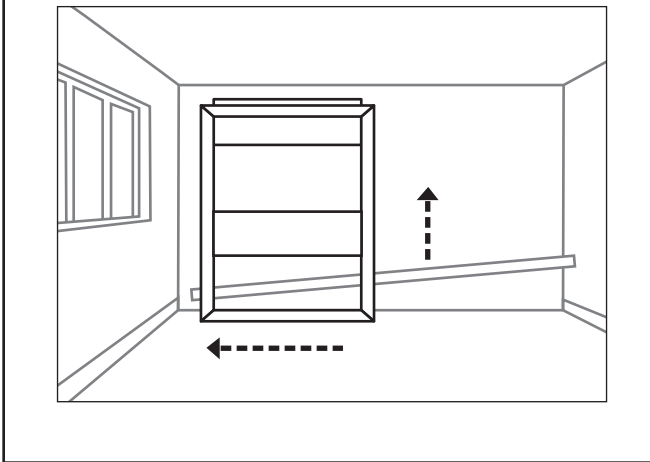

- 3** Put the bed back in its place. Level by adjusting the legs PA-844 previously installed. If you install the bed on a carpet, you must raise the bed by an extra 3/8 in (10 mm).

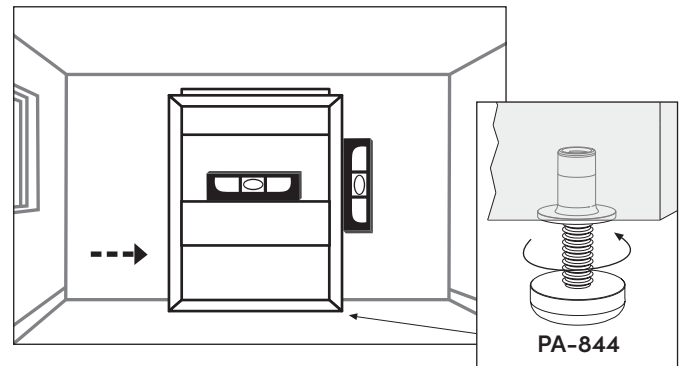

- 4** Pre-drill the back panel with 2 pilot holes of 1/8 in (3 mm) diameter, one on the left and one on the right. With the bed in position, mark the position of the 2 holes on the masonry wall.

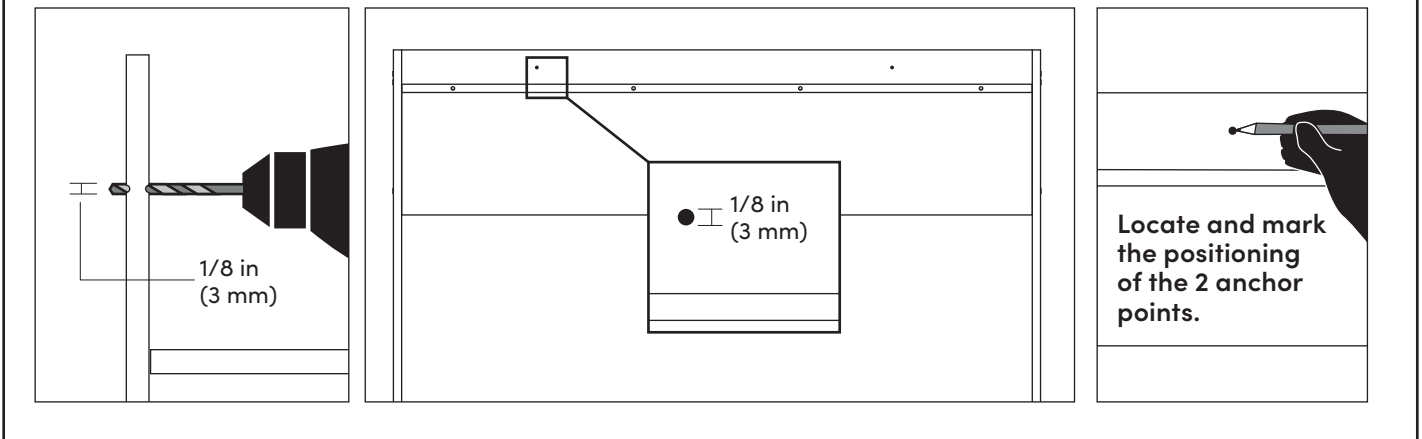

Have an assembly question or need a replacement part? Just call 1-800-950-4782, we are here to help.

¿Tiene alguna pregunta sobre el montaje o necesita una pieza de repuesto? Simplemente llame al 1-800-950-4782, estamos aquí para ayudarle.

Vous avez une question concernant l'assemblage ou vous avez besoin d'une pièce de rechange? Appelez au 1-800-950-4782, nous sommes là pour vous aider.

WALL ANCHORING INSTRUCTIONS MASONRY

INSTALLATION RECOMMENDATIONS

5 Move the bed again.

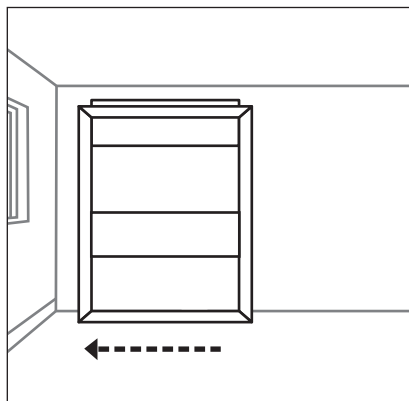

6 Using a 5/32 in (4 mm) diameter masonry bit, drill into the drywall and masonry (a hammer drill is required).

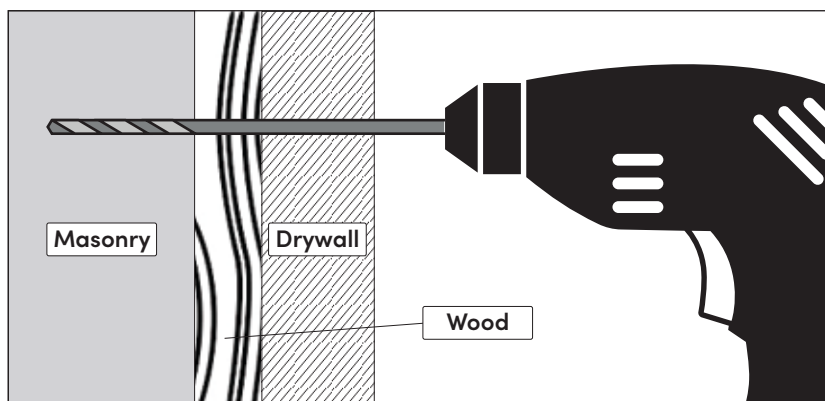

7 Put the bed back in its place.

Put the VB-1134 screws into the holes of back panel and screw the bed onto the masonry wall until tight against the wall. Screw must be at least 1 1/4 in (32 mm) deep into masonry.

USE AN ELECTRIC SCREWDRIVER WITH AN ADJUSTABLE TENSION CLUTCH THAT HELPS PREVENT OVER-TIGHTENING AND STRIPPING.

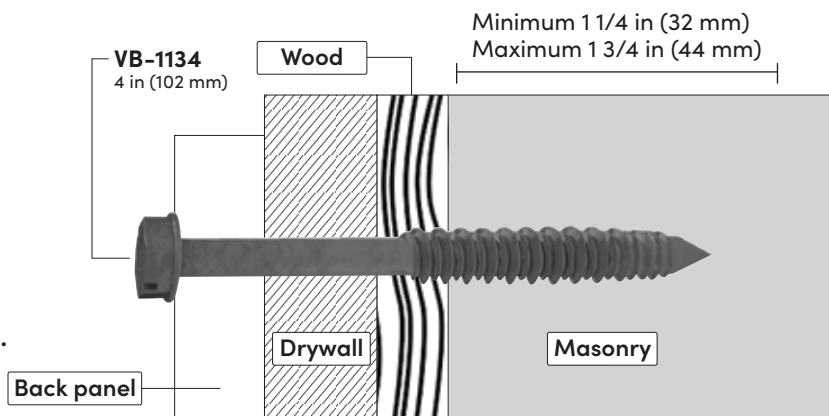

Have an assembly question or need a replacement part? Just call 1-800-950-4782, we are here to help.

¿Tiene alguna pregunta sobre el montaje o necesita una pieza de repuesto? Simplemente llame al 1-800-950-4782, estamos aquí para ayudarle.

Vous avez une question concernant l'assemblage ou vous avez besoin d'une pièce de rechange? Appelez au 1-800-950-4782, nous sommes là pour vous aider.

6 Hardware installation & assembly

Murphy bed

Code	KI-985-Q	KI-7652-O	KI-7652-M	KI-7652-W-2-1	KI-7652-W-2-2	KI-7652-W-1
Qty	x 1	x 4	x 4	x 1	x 1	x 1

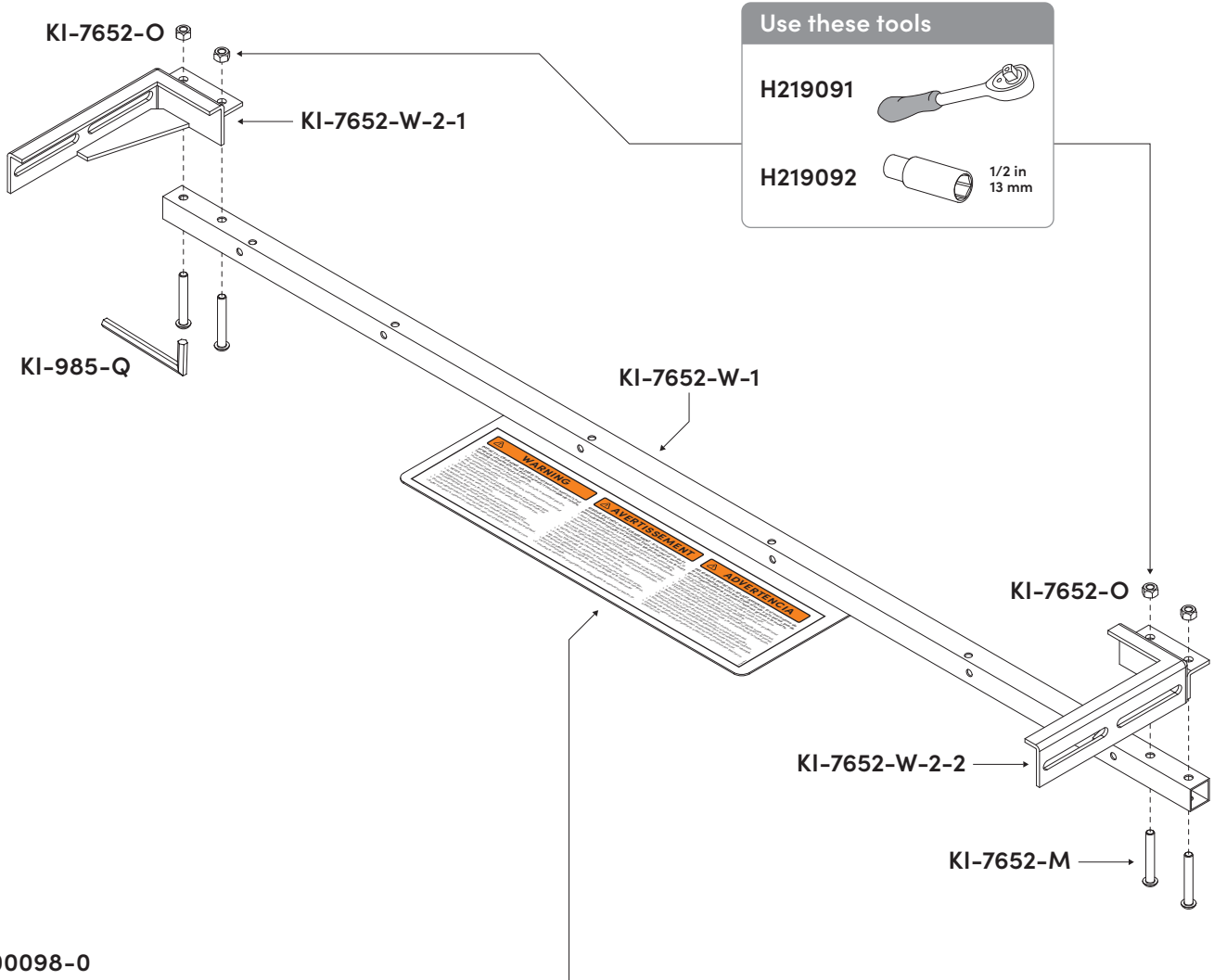

122-00098-0



WARNING

IMPACT or CRUSHING HAZARD: If wall bed mechanism is not properly attached to the floor and wall, it can suddenly rotate, resulting in serious injury or death.

- For wood and masonry floor and wall structure, a qualified person must install the wall bed mechanism.
- For all other type of floor or wall structure, a professional must install the wall bed mechanism.
- The choice of attachment screws depends on floor and wall type. Use attachment screws suitable for your floor and wall material.
- Verify structural integrity of floor and wall prior to installation.
- NEVER use hollow wall anchors.
- ALWAYS use 12 screws for floor and wall attachment.
- NEVER remove floor and wall attachment screws without first disassembling and removing the lift cylinders and mattress frame.
- Only a professional or qualified person should disassemble this wall bed.
- Disassemble product in reverse order of initial assembly.
- Refer to owner's manual or download manual at bestar.ca or bestar.com



AVERTISSEMENT

RISQUE DE CHOC ou D'ÉCRASEMENT : Si le mécanisme du lit escamotable n'est pas correctement fixé au plancher et au mur, il peut subitement pivoter, entraînant des blessures graves ou la mort.

- Pour les structures de murs et de planchers en bois et en maçonnerie, une personne qualifiée doit installer le mécanisme du lit escamotable.
- Pour tout autre type de structure de mur et de plancher, un professionnel doit installer le mécanisme du lit escamotable.
- Le choix de vis de fixation dépend du type de plancher et de votre mur. Utilisez des vis de fixation adaptées au matériau de votre plancher et de votre mur.
- Vérifiez l'intégrité structurale du plancher et du mur avant l'installation.
- N'utilisez JAMAIS de chevilles pour cloison sèche.
- Utilisez TOUJOURS 12 vis pour la fixation au sol et au mur.
- Ne retirez JAMAIS les vis de fixation au sol et au mur sans avoir préalablement démonté et retiré les vérins de levage et le cadre du matelas.
- Seul un professionnel ou une personne qualifiée devrait démonter ce lit escamotable.
- Consultez le manuel du propriétaire ou téléchargez le manuel sur bestar.ca.



ADVERTENCIA

PELIGRO DE IMPACTO o APLASTAMIENTO: Si el mecanismo de la cama abatible no está bien fijado al suelo y a la pared, puede girar repentinamente y provocar lesiones graves o la muerte.

- Para suelos y paredes de madera y mampostería, una persona cualificada debe instalar el mecanismo de la cama abatible.
- Para cualquier otro tipo de estructura de suelo o pared, un profesional debe instalar el mecanismo de la cama abatible.
- La elección de los tornillos de fijación depende del tipo de suelo y pared. Utilice tornillos de fijación adecuados para el material del suelo y la pared.
- Verifique la integridad estructural del suelo y la pared antes de la instalación.
- Nunca utilice anclajes de pared huecos.
- Utilice siempre 12 tornillos para la fijación al suelo y a la pared.
- Nunca retire los tornillos de fijación al suelo y a la pared sin antes desmontar y retirar los cilindros de elevación y el armazón del colchón.
- Sólo un profesional o persona cualificada debe desmontar esta cama abatible.
- Desmonte el producto en el orden inverso al del montaje inicial.
- Consulte el manual del propietario o descargue el manual en bestar.ca o bestar.com.

122-00098-0

Have an assembly question or need a replacement part? Just call 1-800-950-4782, we are here to help.

¿Tiene alguna pregunta sobre el montaje o necesita una pieza de repuesto? Simplemente llame al 1-800-950-4782, estamos aquí para ayudarle.

Vous avez une question concernant l'assemblage ou vous avez besoin d'une pièce de rechange? Appelez au 1-800-950-4782, nous sommes là pour vous aider.

7 Hardware installation & assembly
Murphy bed



5/8 in (16 mm)



Code	KI-985-M	KI-7652-C	KI-7652-D
Qty	x 6	x 1	x 1

CA-7641

KI-7652-C

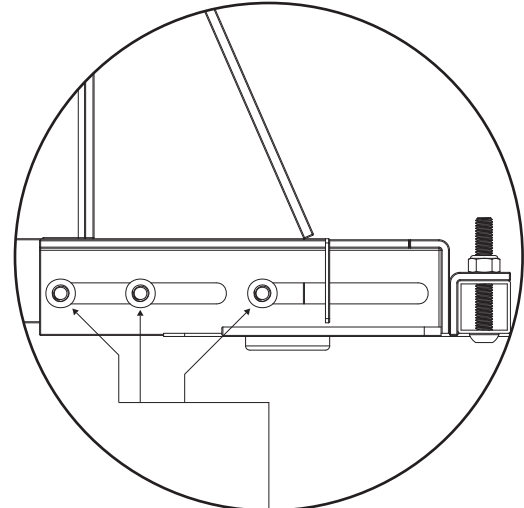
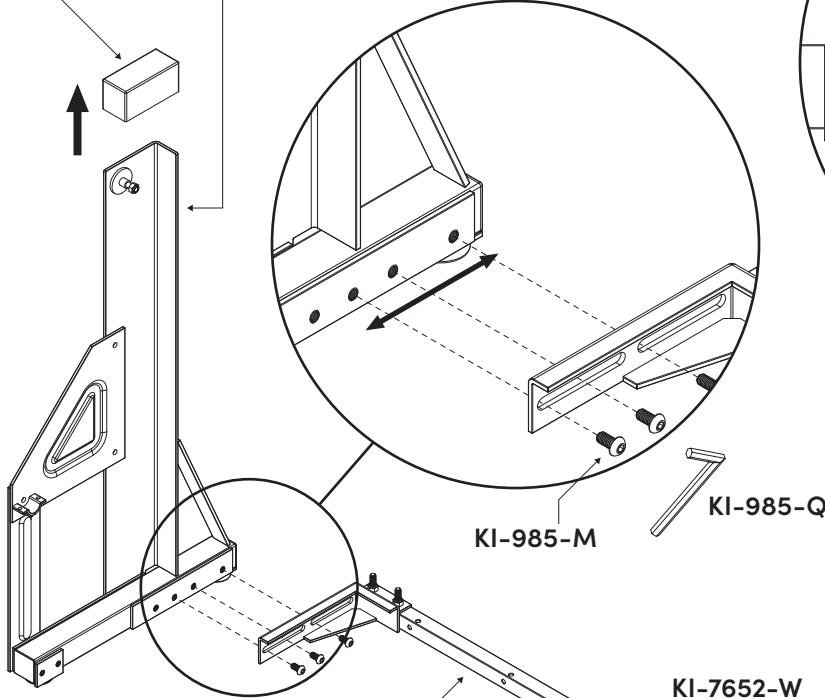

NOTICE
Use the 3 back holes without fully tightening the KI-985-M.

This part can move toward the front or the back.

KI-7652-W

KI-7652-D

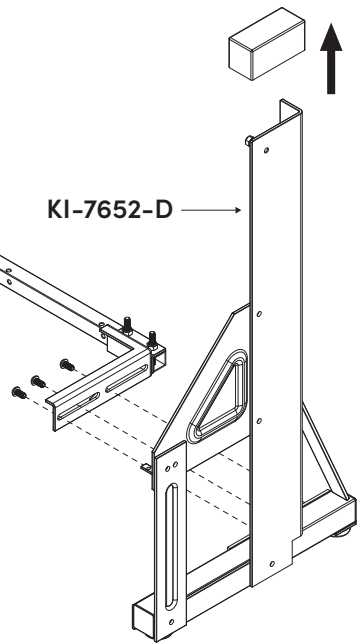

Have an assembly question or need a replacement part? Just call 1-800-950-4782, we are here to help.

¿Tiene alguna pregunta sobre el montaje o necesita una pieza de repuesto? Simplemente llame al 1-800-950-4782, estamos aquí para ayudarle.

Vous avez une question concernant l'assemblage ou vous avez besoin d'une pièce de rechange? Appelez au 1-800-950-4782, nous sommes là pour vous aider.

8

Hardware installation & assembly
Murphy bed



5/8 in (16 mm)

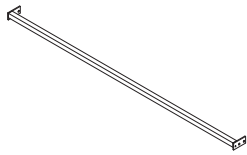

Code KI-985-M

KI-7652-V

Qty x 4

x 1

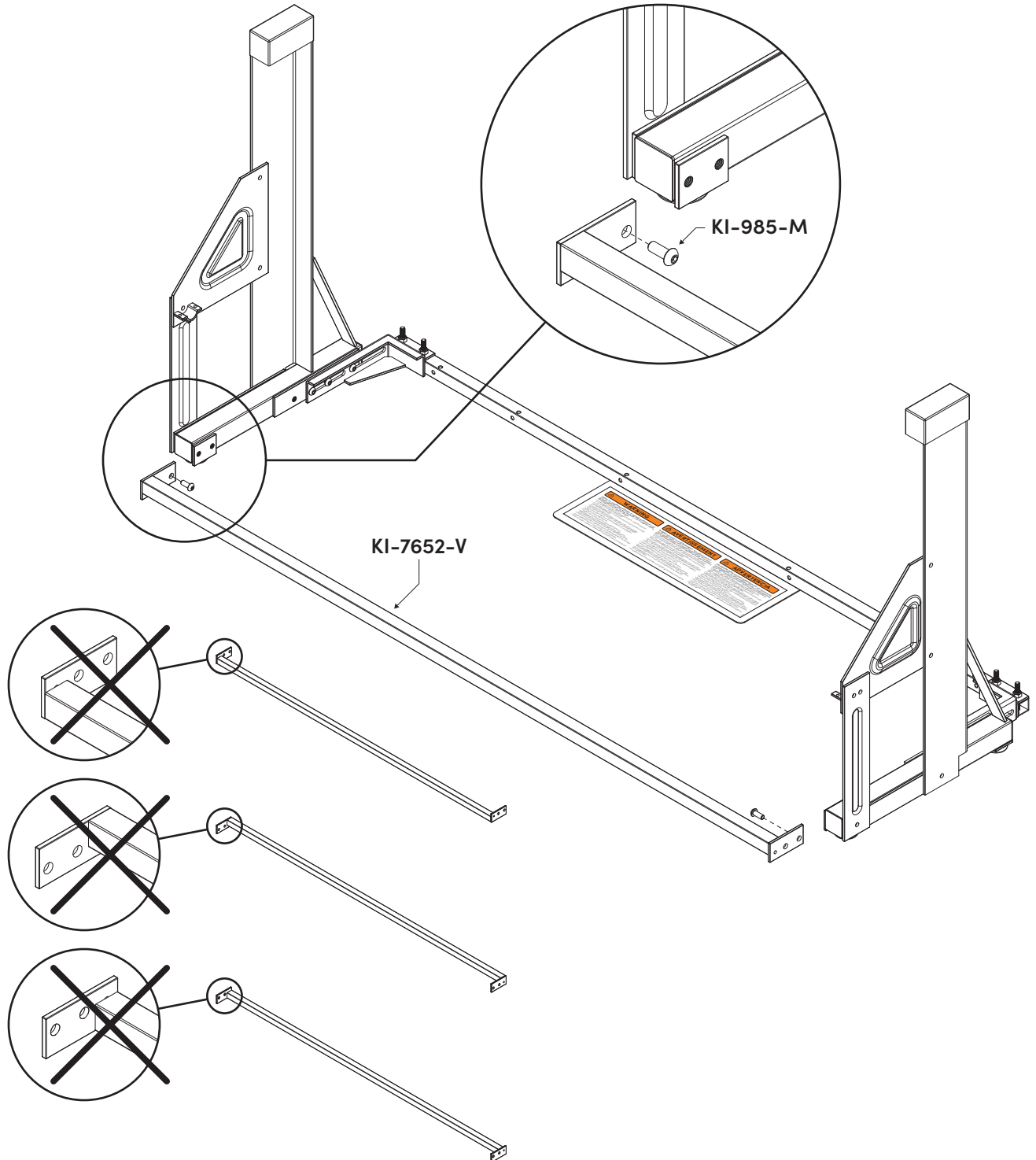

Have an assembly question or need a replacement part? Just call 1-800-950-4782, we are here to help.

¿Tiene alguna pregunta sobre el montaje o necesita una pieza de repuesto? Simplemente llame al 1-800-950-4782, estamos aquí para ayudarle.

Vous avez une question concernant l'assemblage ou vous avez besoin d'une pièce de rechange? Appelez au 1-800-950-4782, nous sommes là pour vous aider.

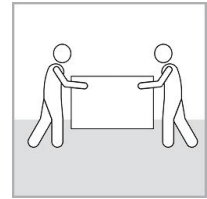

Team Lift
 Esfuerzo de equipo
 Effort d'équipe

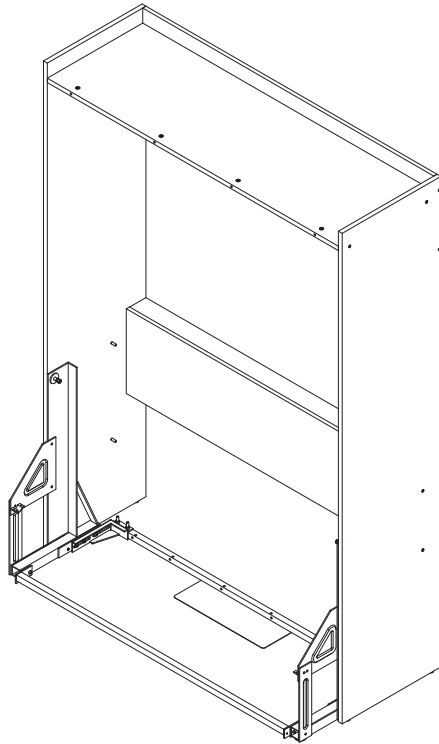

Insert the
 metal base
 that you have
 just assembled.

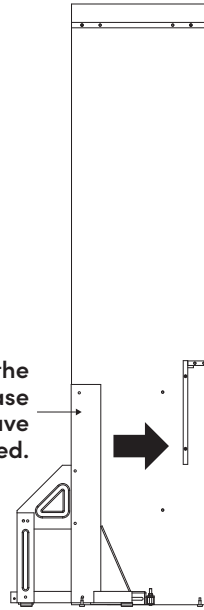

Push the
 metal base
 in until you
 touch the
 wooden
 dowels.

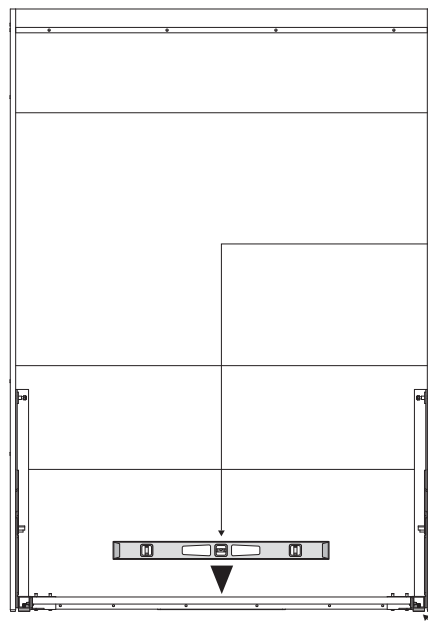
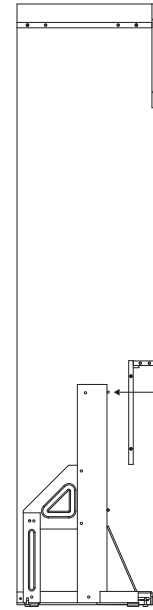

Place a leveler on the tube.

NOTICE

If you install the bed on a carpet, you must raise the bed by an extra 3/8 in (10 mm).



Adjust the leg levelers until the tube is level.

Have an assembly question or need a replacement part? Just call 1-800-950-4782, we are here to help.

¿Tiene alguna pregunta sobre el montaje o necesita una pieza de repuesto? Simplemente llame al 1-800-950-4782, estamos aquí para ayudarle.

Vous avez une question concernant l'assemblage ou vous avez besoin d'une pièce de rechange? Appelez au 1-800-950-4782, nous sommes là pour vous aider.

10 Assembly
Murphy bed

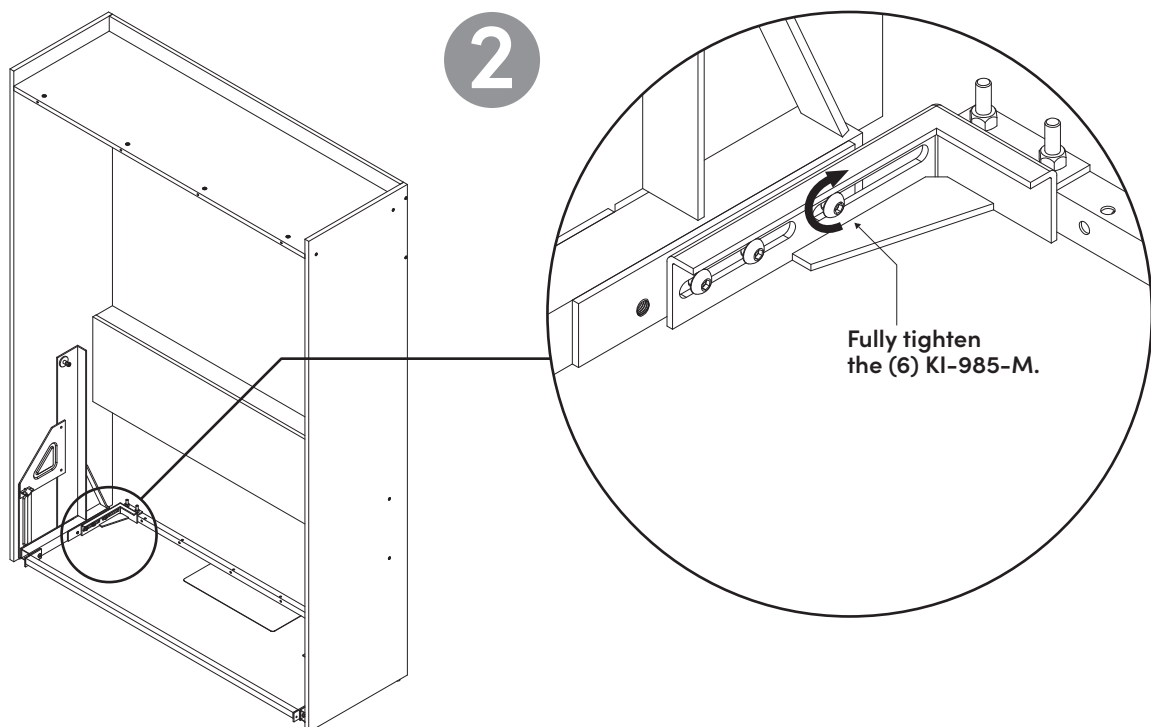
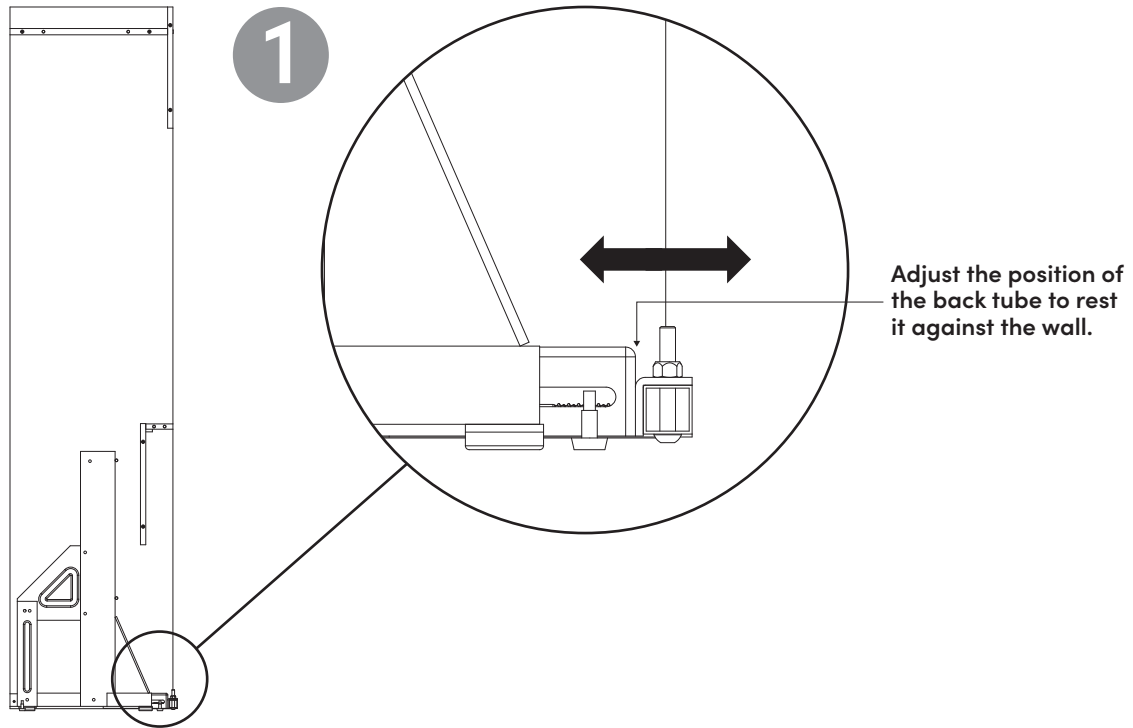

Have an assembly question or need a replacement part? Just call 1-800-950-4782, we are here to help.

¿Tiene alguna pregunta sobre el montaje o necesita una pieza de repuesto? Simplemente llame al 1-800-950-4782, estamos aquí para ayudarle.

Vous avez une question concernant l'assemblage ou vous avez besoin d'une pièce de rechange? Appelez au 1-800-950-4782, nous sommes là pour vous aider.



5/8 in (16 mm)

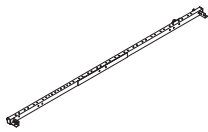

KI-7652-A-1

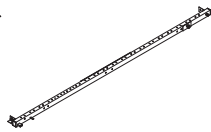

KI-7652-A-2

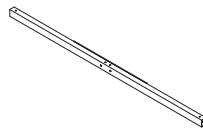

KI-7652-A-3

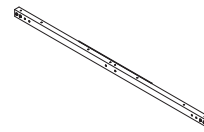

KI-7652-A-4

Code

KI-985-M

KI-7652-A-1

KI-7652-A-2

KI-7652-A-3

KI-7652-A-4

Qty

x 4

x 1

x 1

x 1

x 1

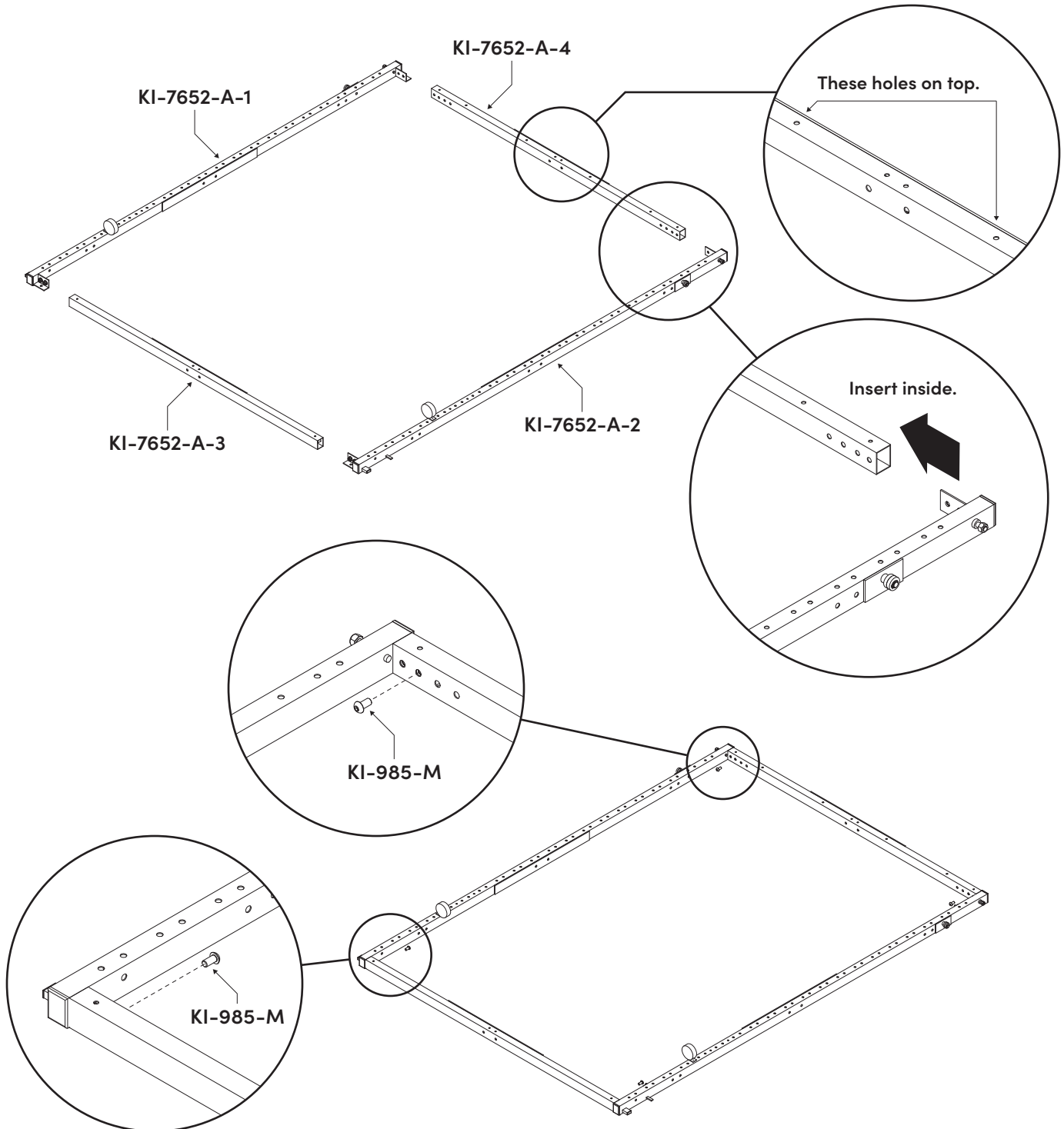



Have an assembly question or need a replacement part? Just call 1-800-950-4782, we are here to help.

¿Tiene alguna pregunta sobre el montaje o necesita una pieza de repuesto? Simplemente llame al 1-800-950-4782, estamos aquí para ayudarle.

Vous avez une question concernant l'assemblage ou vous avez besoin d'une pièce de rechange? Appelez au 1-800-950-4782, nous sommes là pour vous aider.

12 Hardware installation & assembly
Murphy bed

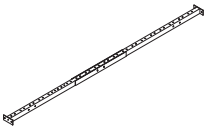
			
Code	KI-7652-O	KI-7652-M	KI-7652-A-5
Qty	x 4	x 4	x 1

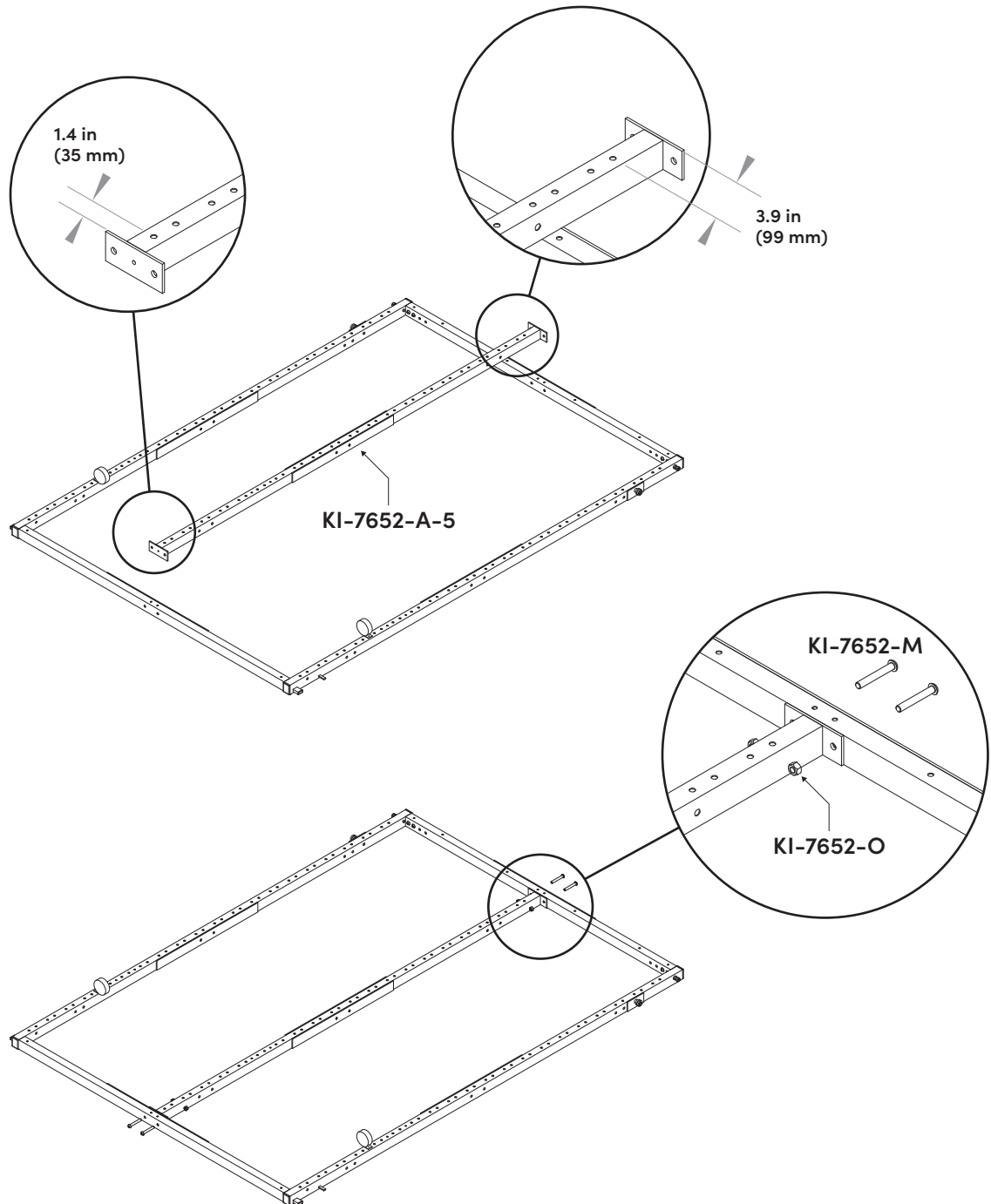



Have an assembly question or need a replacement part? Just call 1-800-950-4782, we are here to help.

¿Tiene alguna pregunta sobre el montaje o necesita una pieza de repuesto? Simplemente llame al 1-800-950-4782, estamos aquí para ayudarle.

Vous avez une question concernant l'assemblage ou vous avez besoin d'une pièce de rechange? Appelez au 1-800-950-4782, nous sommes là pour vous aider.

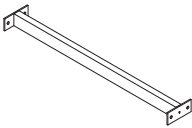
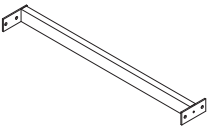
13 Hardware installation & assembly
Murphy bed

					
Code	KI-985-E	KI-7652-A-6	KI-7652-A-7	KI-7652-O	KI-7652-M
Qty	x 2	x 2	x 4	x 18	x 18

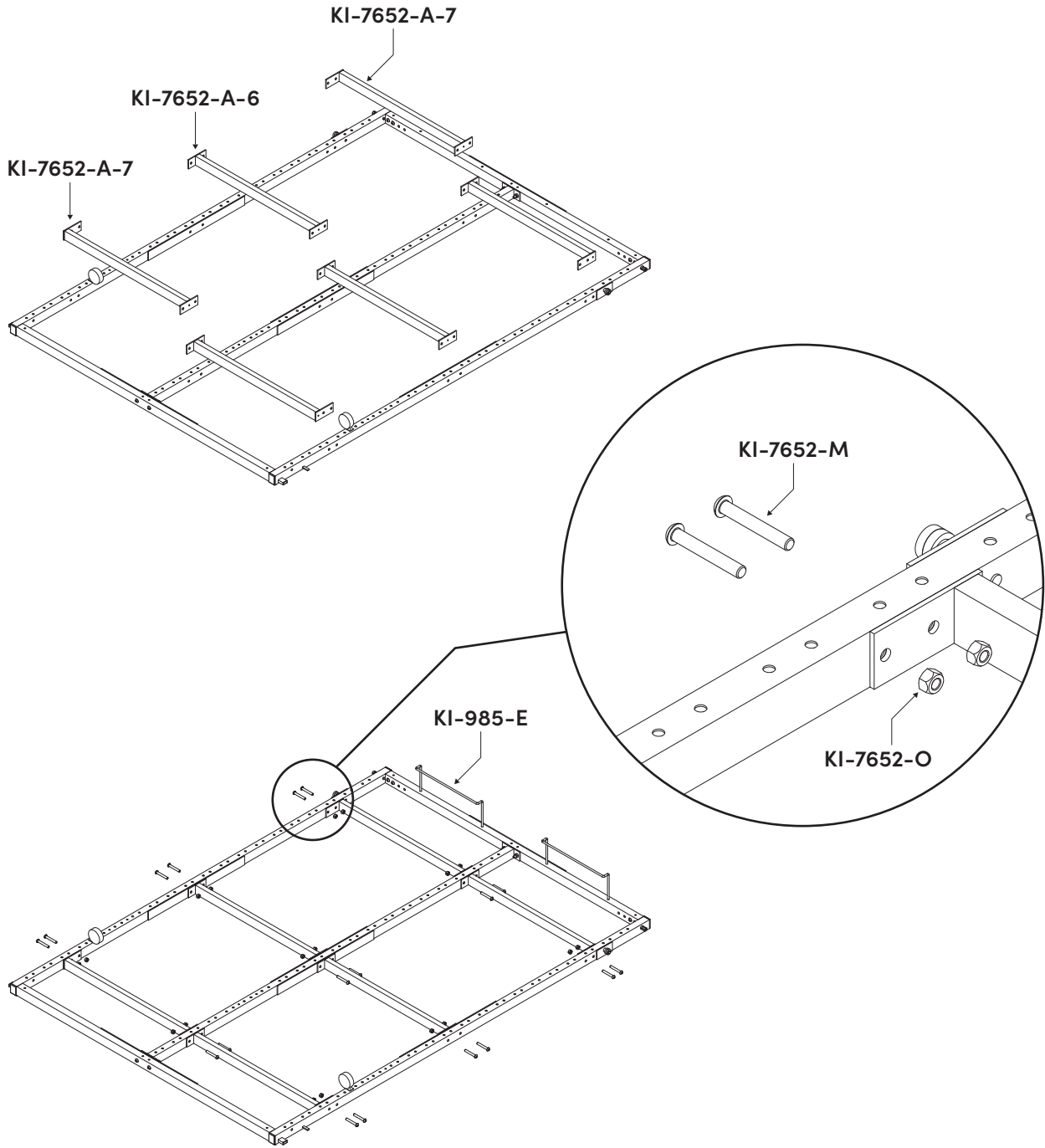

Have an assembly question or need a replacement part? Just call 1-800-950-4782, we are here to help.

¿Tiene alguna pregunta sobre el montaje o necesita una pieza de repuesto? Simplemente llame al 1-800-950-4782, estamos aquí para ayudarle.

Vous avez une question concernant l'assemblage ou vous avez besoin d'une pièce de rechange? Appelez au 1-800-950-4782, nous sommes là pour vous aider.

14 Assembly
Murphy bed

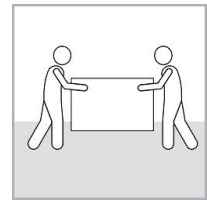

Team Lift
Esfuerzo de equipo
Effort d'équipe

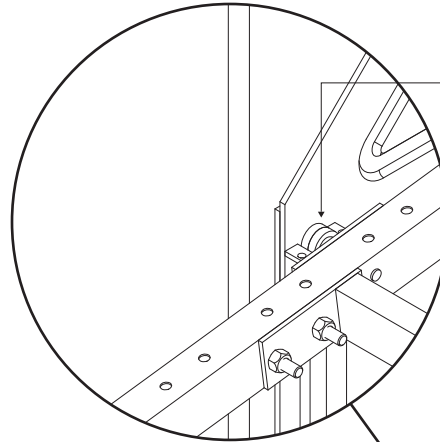
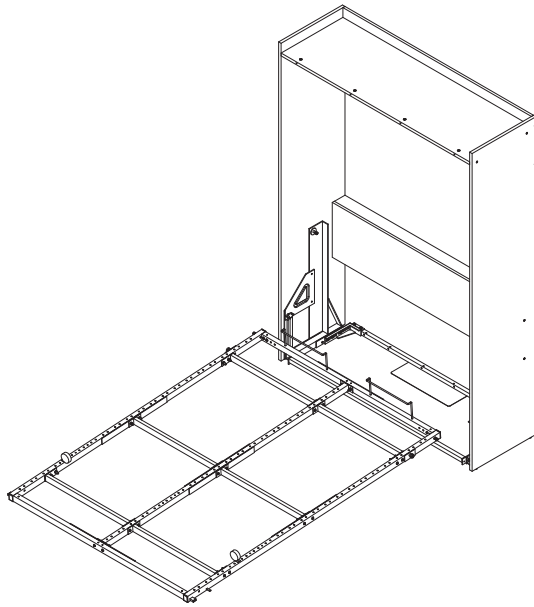

**Place the bearing
inside the bearing
support.**

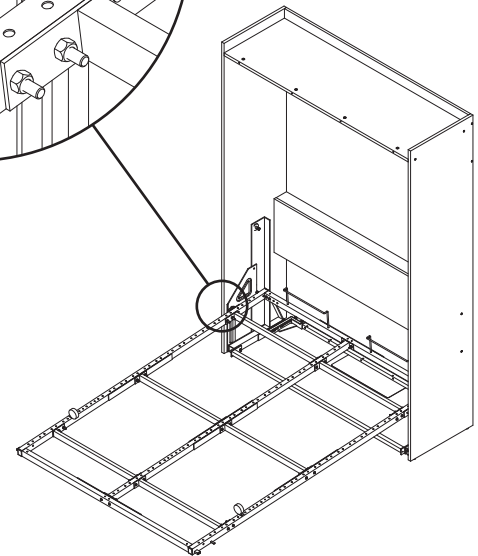

**Close the
metal frame.**

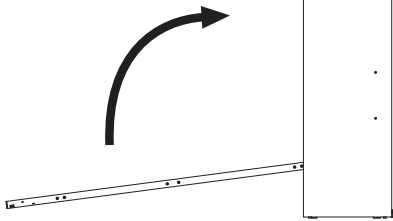

**Distance between metal frame and
wood gable must be the same each side.**

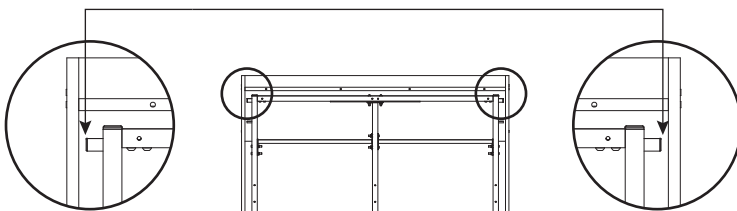

**Move the base to adjust
the distance on top.**

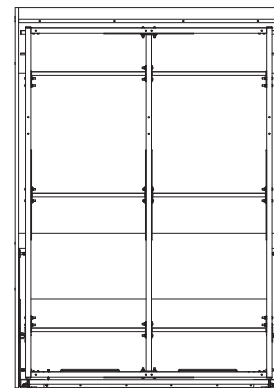

**Mark the bottom
of your wall.**

Have an assembly question or need a replacement part? Just call 1-800-950-4782, we are here to help.

¿Tiene alguna pregunta sobre el montaje o necesita una pieza de repuesto? Simplemente llame al 1-800-950-4782, estamos aquí para ayudarle.

Vous avez une question concernant l'assemblage ou vous avez besoin d'une pièce de rechange? Appelez au 1-800-950-4782, nous sommes là pour vous aider.

15 Assembly
Murphy bed

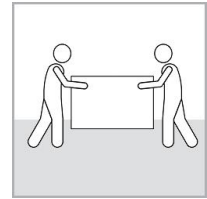

Team Lift
Esfuerzo de equipo
Effort d'équipe

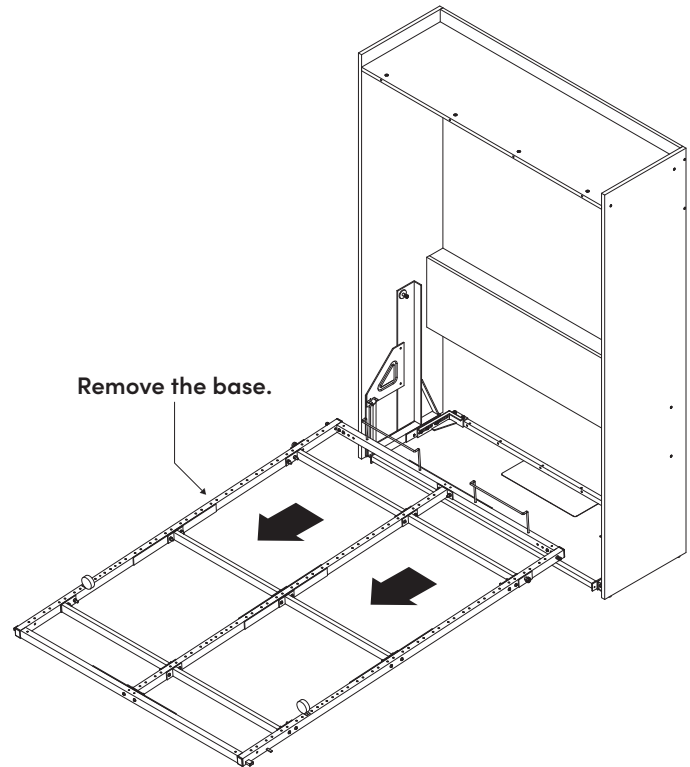
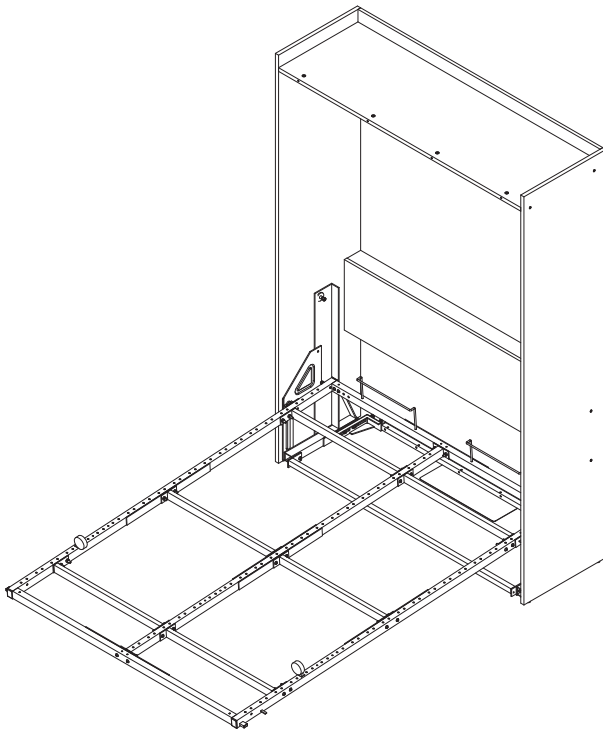
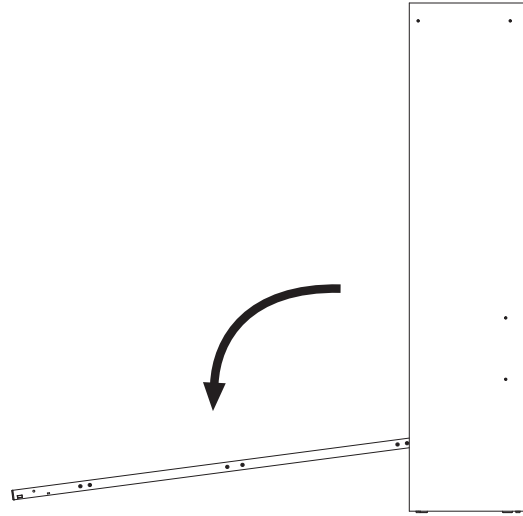
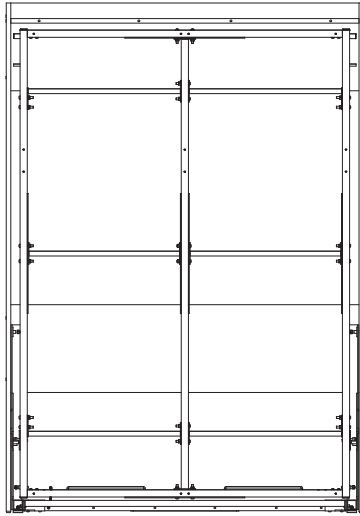

Have an assembly question or need a replacement part? Just call 1-800-950-4782, we are here to help.

¿Tiene alguna pregunta sobre el montaje o necesita una pieza de repuesto? Simplemente llame al 1-800-950-4782, estamos aquí para ayudarle.

Vous avez une question concernant l'assemblage ou vous avez besoin d'une pièce de rechange? Appelez au 1-800-950-4782, nous sommes là pour vous aider.

WALL ANCHORING REQUIREMENTS & INSTALLATION RECOMMENDATIONS

Important information to read before starting the assembly.
Keep this information for future reference.



WARNING

IMPACT OR CRUSHING HAZARD: If bed is not properly attached to the wall and floor, it can suddenly fall, resulting in serious injury or death.

- For wood or masonry wall structure, a qualified person must install the bed to the wall.
- For all other types, a construction professional must install the bed to the wall in compliance with the codes and regulations in the province, state, or country where installed.
- The choice of wall attachment screw depends on wall type. Use wall attachment screws suitable for your wall material.
- Verify structural integrity of floor and wall prior to installation.
- Do not open or use the bed if the bed cabinet moves while opening, or if you notice any other signs of loose or detaching screws.
- Never remove wall and floor attachment screws without first disassembling and removing the mattress frame and lift cylinders.
- Qualified person must have the skills and tools necessary to locate wall studs, identify type of wall structure (wood, metal, masonry or other) and install screws correctly to wall structure. Skills and tools include electronic stud finder, drill motor and bits, screwdriver, and ability to correctly use these tools.



WARNING

IMPACT OR CRUSHING HAZARD: If bed is not properly attached to the wall, it can suddenly fall, resulting in serious injury or death.

- NEVER use hollow-wall or drywall anchors.
- NEVER attach wall bed directly to drywall, sheetrock, gypsum, or other wall board.
- ALWAYS attach wall bed to base of wall and floor.
- ALWAYS use twelve (12) screws for floor and wall attachment.

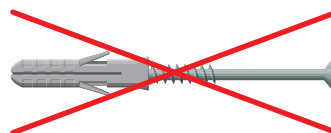

Have an assembly question or need a replacement part? Just call 1-800-950-4782, we are here to help.

¿Tiene alguna pregunta sobre el montaje o necesita una pieza de repuesto? Simplemente llame al 1-800-950-4782, estamos aquí para ayudarle.

Vous avez une question concernant l'assemblage ou vous avez besoin d'une pièce de rechange? Appelez au 1-800-950-4782, nous sommes là pour vous aider.

WALL ANCHORING INSTRUCTIONS

ATTACHING THE PIVOT MECHANISM TO THE WALL AND FLOOR STRUCTURE

INSTALLATION RECOMMENDATIONS

1

FIXATION ON SILL PLATE.

2

Drill a 1/8 in or 3 mm pilot hole into the wall to determine the type of structure present.

3

WOOD found behind the wall board?

- Use a 1/8 in drill to create pilot holes in the wall aligned with the holes on the metal tube.
- Use the 6 VB-1134 screws.

VB-1134
4 in (102 mm)



4

CONCRETE found behind the wall board?

- Use a 5/32 in masonry drill to create pilot holes in the wall aligned with the holes on the metal tube.
- Use the 6 VB-1134 screws.

VB-1134
4 in (102 mm)



122-00098-0



WARNING

IMPACT or CRUSHING HAZARD: If wall bed mechanism is not properly attached to the floor and wall, it can suddenly rotate, resulting in serious injury or death.

- For wood and masonry floor and wall structure, a qualified person must install the wall bed mechanism.
- For all other type of floor or wall structure, a professional must install the wall bed mechanism.
- The choice of attachment screws depends on floor and wall type. Use attachment screws suitable for your floor and wall material.
- Verify structural integrity of floor and wall prior to installation.
- NEVER use hollow wall anchors.
- ALWAYS use 12 screws for floor and wall attachment.
- NEVER remove floor and wall attachment screws without first disassembling and removing the lift cylinders and mattress frame.
- Only a professional or qualified person should disassemble this wall bed.
- Disassemble product in reverse order of initial assembly.
- Refer to owner's manual or download manual at bestar.ca or bestar.com



AVERTISSEMENT

RISQUE DE CHOC ou D'ÉCRASEMENT : Si le mécanisme du lit escamotable n'est pas correctement fixé au plancher et au mur, il peut subitement pivoter, entraînant des blessures graves ou la mort.

- Pour les structures de murs et de planchers en bois et en maçonnerie, une personne qualifiée doit installer le mécanisme du lit escamotable.
- Pour tout autre type de structure de mur et de plancher, un professionnel doit installer le mécanisme du lit escamotable.
- Le choix de vis de fixation dépend du type de plancher et de mur. Utilisez des vis de fixation adaptées au matériau de votre plancher et de votre mur.
- Vérifiez l'intégrité structurale du plancher et du mur avant l'installation.
- N'utilisez JAMAIS de chevilles pour cloison sèche.
- Utilisez TOUJOURS 12 vis pour la fixation au sol et au mur.
- Ne retirez JAMAIS les vis de fixation au sol et au mur sans avoir préalablement démonté et retiré les vérins de levage et le cadre du matelas.
- Seul un professionnel ou une personne qualifiée devrait démonter ce lit escamotable.
- Consultez le manuel du propriétaire ou téléchargez le manuel sur bestar.ca.



ADVERTENCIA

PELIGRO DE IMPACTO o APLASTAMIENTO: Si el mecanismo de la cama abatible no está bien fijado al suelo y a la pared, puede girar repentinamente y provocar lesiones graves o la muerte.

- Para suelos y paredes de madera y mampostería, una persona cualificada debe instalar el mecanismo de la cama mural.
- Para cualquier otro tipo de estructura de suelo o pared, un profesional debe instalar el mecanismo de la cama abatible.
- La elección de los tornillos de fijación depende del tipo de suelo y pared. Utilice tornillos de fijación adecuados para el material del suelo y la pared.
- Verifique la integridad estructural del suelo y la pared antes de la instalación.
- Nunca utilice anclajes de pared huecos.
- Utilice siempre 12 tornillos para la fijación al suelo y a la pared.
- Nunca retire los tornillos de fijación al suelo y a la pared sin antes desmontar y retirar los cilindros de elevación y el armazón del colchón.
- Sólo un profesional o persona cualificada debe desmontar esta cama abatible.
- Desmonte el producto en el orden inverso al del montaje inicial.
- Consulte el manual del propietario o descargue el manual en bestar.ca o bestar.com.

Have an assembly question or need a replacement part? Just call 1-800-950-4782, we are here to help.

¿Tiene alguna pregunta sobre el montaje o necesita una pieza de repuesto? Simplemente llame al 1-800-950-4782, estamos aquí para ayudarle.

Vous avez une question concernant l'assemblage ou vous avez besoin d'une pièce de rechange? Appelez au 1-800-950-4782, nous sommes là pour vous aider.

WALL ANCHORING INSTRUCTIONS

INSTALLATION RECOMMENDATIONS

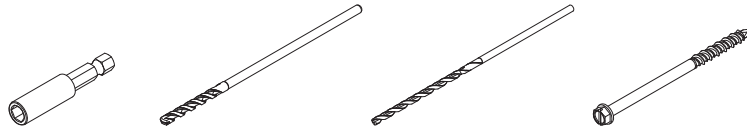

Code	BT-1137	FO-1136	H206515	VB-1134
Qty	x 1	x 1	x 1	x 6

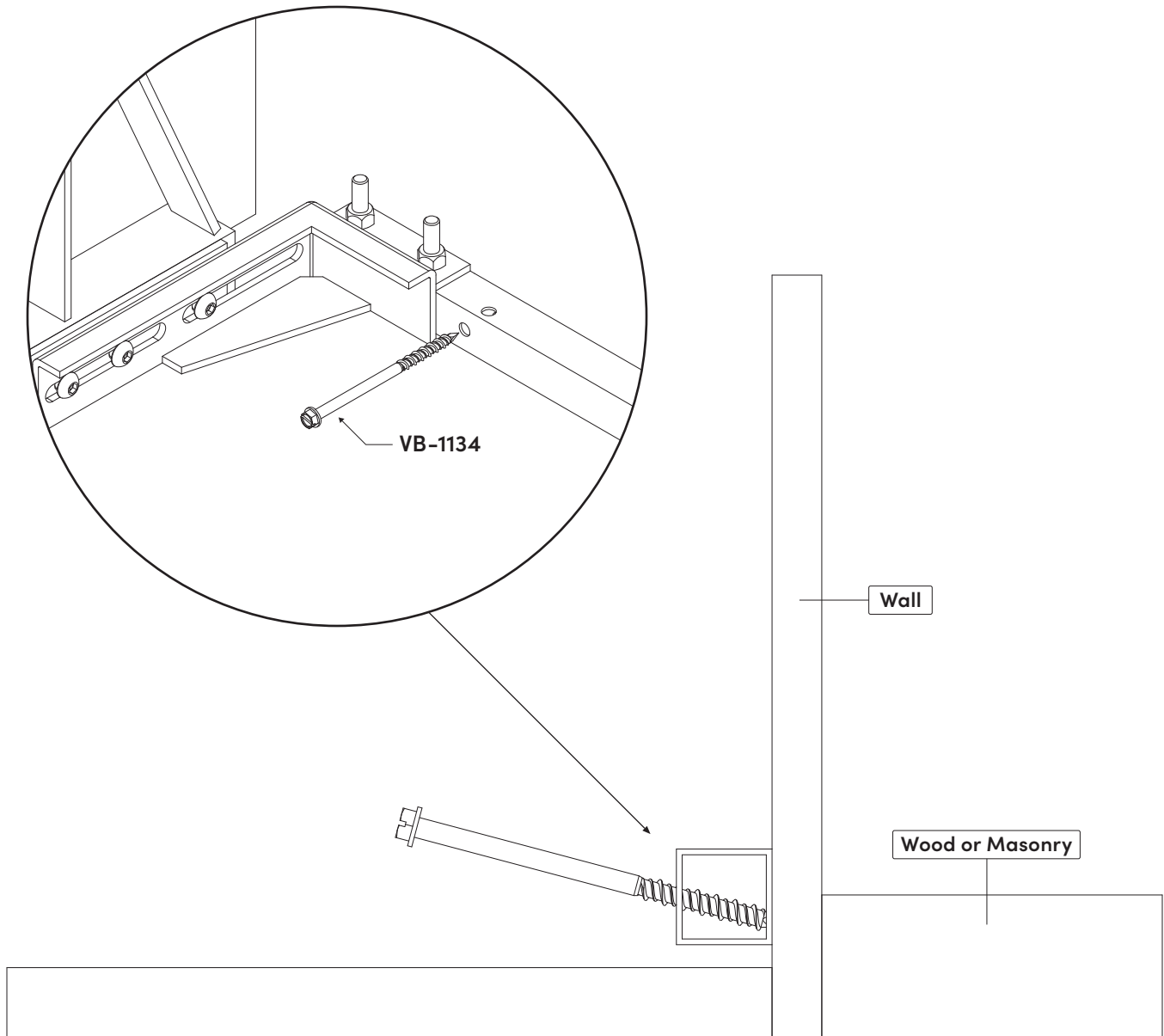

Have an assembly question or need a replacement part? Just call 1-800-950-4782, we are here to help.

¿Tiene alguna pregunta sobre el montaje o necesita una pieza de repuesto? Simplemente llame al 1-800-950-4782, estamos aquí para ayudarle.

Vous avez une question concernant l'assemblage ou vous avez besoin d'une pièce de rechange? Appelez au 1-800-950-4782, nous sommes là pour vous aider.

FLOOR ANCHORING INSTRUCTIONS

INSTALLATION RECOMMENDATIONS

1

FIXATION ON FLOOR.

2

Drill a 1/8 in or 3 mm pilot hole into floor to determine the type of floor structure present.

3

WOOD found behind the floor?

- Use a 1/8 in drill to create pilot holes in the floor aligned with the holes on the metal tube.
- Use the 6 VB-1135 screws.

VB-1135
2 3/4 in (70 mm)

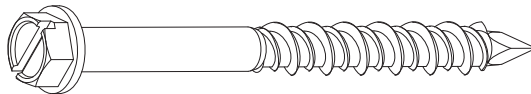

4

CONCRETE found behind the floor?

- Use a 5/32 in masonry drill to create pilot holes in the floor aligned with the holes on the metal tube.
- Use the masonry 6 VB-1135 screws.

VB-1135
2 3/4 in (70 mm)

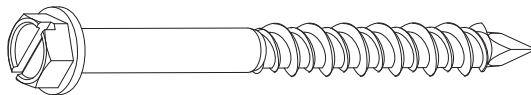

122-00098-0



WARNING

IMPACT or CRUSHING HAZARD: If wall bed mechanism is not properly attached to the floor and wall, it can suddenly rotate, resulting in serious injury or death.

- For wood and masonry floor and wall structure, a qualified person must install the wall bed mechanism.
- For all other type of floor or wall structure, a professional must install the wall bed mechanism.
- The choice of attachment screws depends on floor and wall type. Use attachment screws suitable for your floor and wall material.
- Verify structural integrity of floor and wall prior to installation.
- NEVER use hollow wall anchors.
- ALWAYS use 12 screws for floor and wall attachment.
- NEVER remove floor and wall attachment screws without first disassembling and removing the lift cylinders and mattress frame.
- Only a professional or qualified person should disassemble this wall bed.
- Disassemble product in reverse order of initial assembly.
- Refer to owner's manual or download manual at bestar.ca or bestar.com



AVERTISSEMENT

RISQUE DE CHOC ou D'ÉCRASEMENT : Si le mécanisme du lit escamotable n'est pas correctement fixé au plancher et au mur, il peut subitement pivoter, entraînant des blessures graves ou la mort.

- Pour les structures de murs et de planchers en bois et en maçonnerie, une personne qualifiée doit installer le mécanisme du lit escamotable.
- Pour tout autre type de structure de mur et de plancher, un professionnel doit installer le mécanisme du lit escamotable.
- Le choix de vis de fixation dépend du type de plancher et de mur. Utilisez des vis de fixation adaptées au matériau de votre plancher et de votre mur.
- Vérifiez l'intégrité structurelle du plancher et du mur avant l'installation.
- N'utilisez JAMAIS de chevilles pour cloison sèche.
- Utilisez TOUJOURS 12 vis pour la fixation au sol et au mur.
- Ne retirez JAMAIS les vis de fixation au sol et au mur sans avoir préalablement démonté et retiré les vérins de levage et le cadre du matelas.
- Seul un professionnel ou une personne qualifiée devrait démonter ce lit escamotable.
- Consultez le manuel du propriétaire ou téléchargez le manuel sur bestar.ca.



ADVERTENCIA

PELIGRO DE IMPACTO o APLASTAMIENTO: Si el mecanismo de la cama abatible no está bien fijado al suelo y a la pared, puede girar repentinamente y provocar lesiones graves o la muerte.

- Para suelos y paredes de madera y mampostería, una persona cualificada debe instalar el mecanismo de la cama mural.
- Para cualquier otro tipo de estructura de suelo o pared, un profesional debe instalar el mecanismo de la cama abatible.
- La elección de los tornillos de fijación depende del tipo de suelo y pared. Utilice tornillos de fijación adecuados para el material del suelo y la pared.
- Verifique la integridad estructural del suelo y la pared antes de la instalación.
- Nunca utilice anclajes de pared huecos.
- Utilice siempre 12 tornillos para la fijación al suelo y a la pared.
- Nunca retire los tornillos de fijación al suelo y a la pared sin antes desmontar y retirar los cilindros de elevación y el armazón del colchón.
- Sólo un profesional o persona cualificada debe desmontar esta cama abatible.
- Desmonte el producto en el orden inverso al del montaje inicial.
- Consulte el manual del propietario o descargue el manual en bestar.ca o bestar.com.

Have an assembly question or need a replacement part? Just call 1-800-950-4782, we are here to help.

¿Tiene alguna pregunta sobre el montaje o necesita una pieza de repuesto? Simplemente llame al 1-800-950-4782, estamos aquí para ayudarle.

Vous avez une question concernant l'assemblage ou vous avez besoin d'une pièce de rechange? Appelez au 1-800-950-4782, nous sommes là pour vous aider.

FLOOR ANCHORING INSTRUCTIONS

INSTALLATION RECOMMENDATIONS

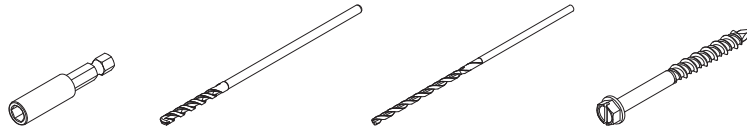

Code	BT-1137	FO-1136	H206515	VB-1135
Qty	x 1	x 1	x 1	x 6

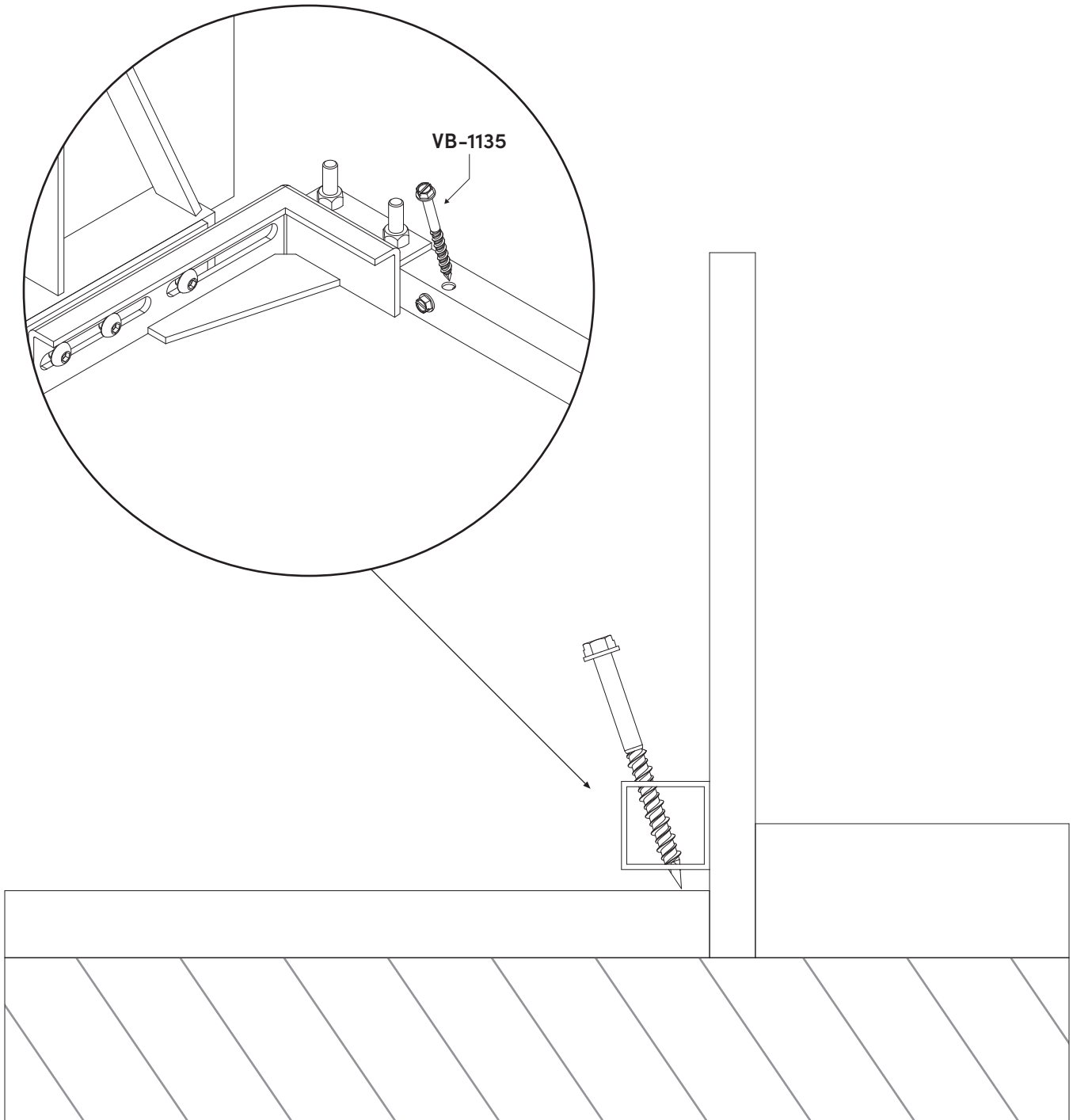

Have an assembly question or need a replacement part? Just call 1-800-950-4782, we are here to help.

¿Tiene alguna pregunta sobre el montaje o necesita una pieza de repuesto? Simplemente llame al 1-800-950-4782, estamos aquí para ayudarle.

Vous avez une question concernant l'assemblage ou vous avez besoin d'une pièce de rechange? Appelez au 1-800-950-4782, nous sommes là pour vous aider.

17 Hardware installation & assembly
Murphy bed

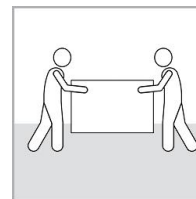

Team Lift
Esfuerzo de equipo
Effort d'équipe

Code	KI-7652-J	LEG WARNING STICKER
Qty	x 2	x 1

NOTICE

Fully tighten 1 nut per cylinder. Nylon side of the nut must face outwards. Thread should extend past end of nut when tightened.

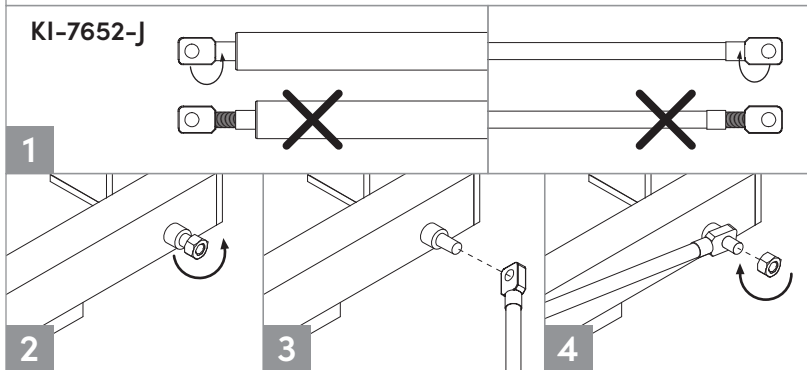

NOTICE

Take note that after the installation of the pistons, it will be very difficult to open the bed. Follow the steps until the end, after mattress and front panels are installed, the bed will open without effort.

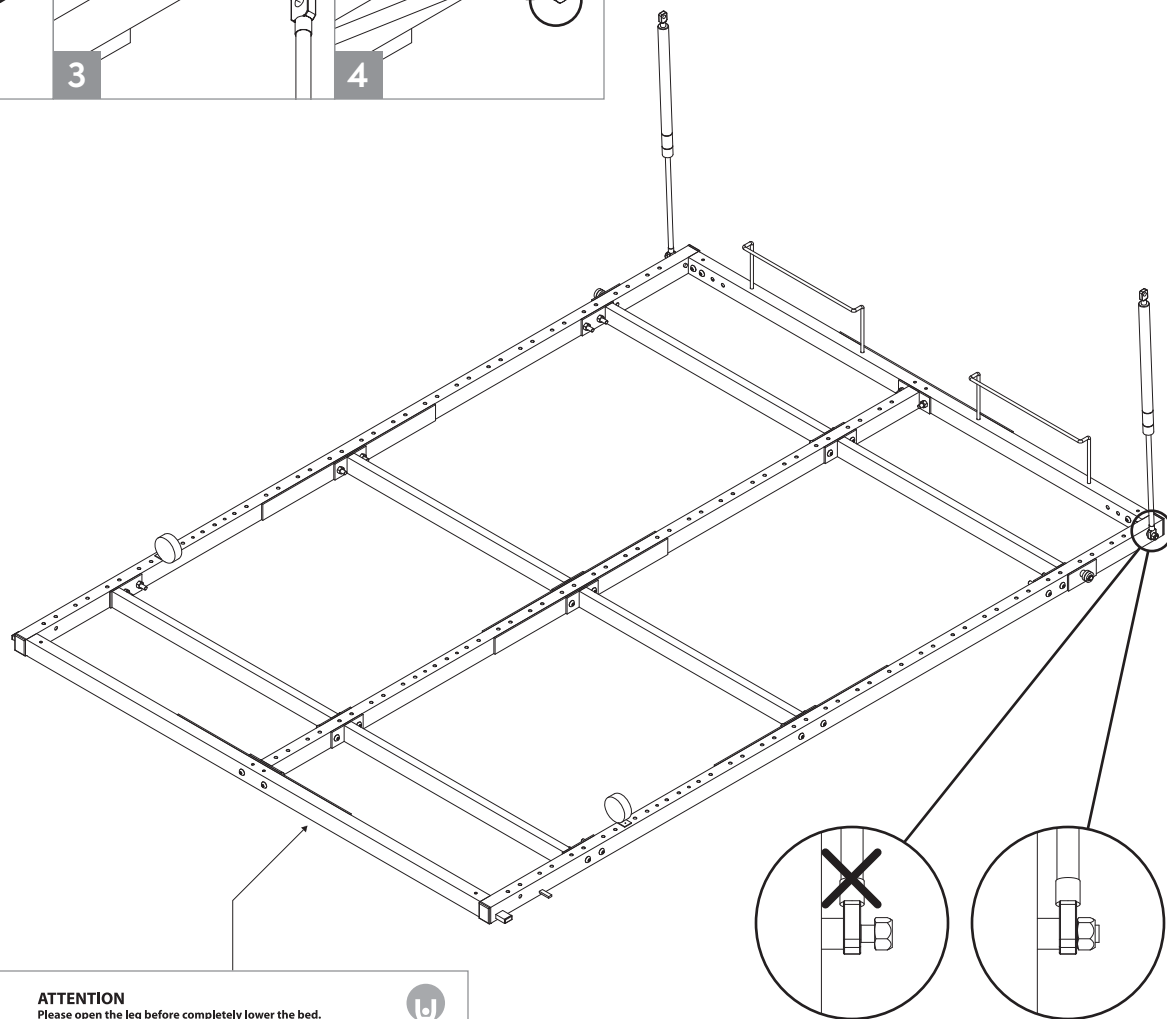

KI-7652-J MUST BE COMPLETELY TIGHTENED

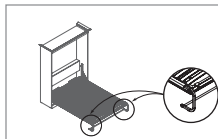

ATTENTION
Please open the leg before completely lower the bed.
Veuillez ouvrir la patte avant d'abaisser complètement le lit.



Maximum capacity: 1000 lbs
Capacité maximale: 450 kg
Costco and Bestar are released from any responsibility if the wall anchor screws are not secure to the wall into studs.
Costco et Bestar se déchargent de toutes responsabilités si les vis d'ancrage ne sont pas fixées au mur dans des montants.

Have an assembly question or need a replacement part? Just call 1-800-950-4782, we are here to help.

¿Tiene alguna pregunta sobre el montaje o necesita una pieza de repuesto? Simplemente llame al 1-800-950-4782, estamos aquí para ayudarle.

Vous avez une question concernant l'assemblage ou vous avez besoin d'une pièce de rechange? Appelez au 1-800-950-4782, nous sommes là pour vous aider.

18 Assembly
Murphy bed



Team Lift
Esfuerzo de equipo
Effort d'équipe

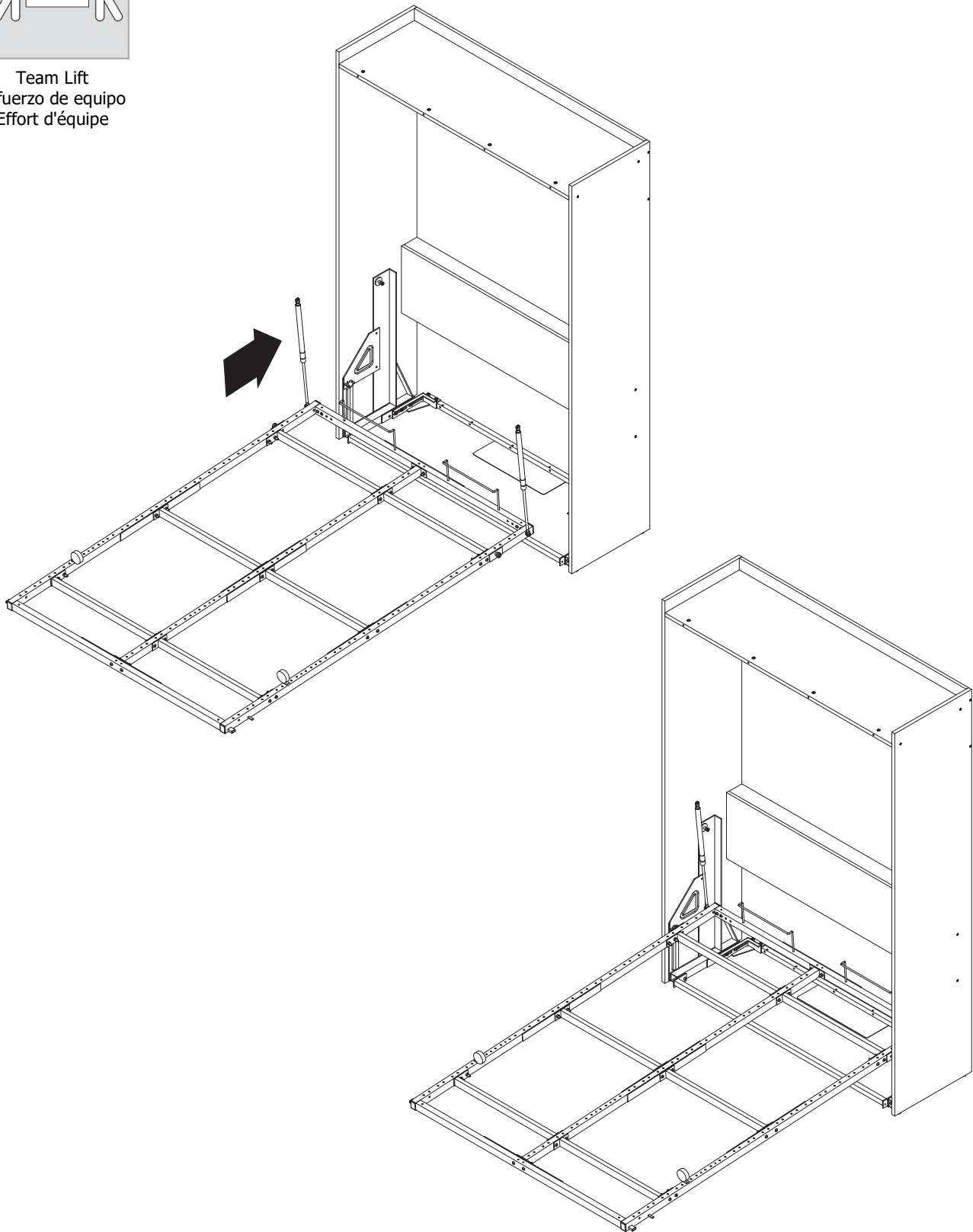

Have an assembly question or need a replacement part? Just call 1-800-950-4782, we are here to help.

¿Tiene alguna pregunta sobre el montaje o necesita una pieza de repuesto? Simplemente llame al 1-800-950-4782, estamos aquí para ayudarle.

Vous avez une question concernant l'assemblage ou vous avez besoin d'une pièce de rechange? Appelez au 1-800-950-4782, nous sommes là pour vous aider.

19 Hardware installation & assembly
Murphy bed

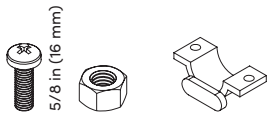

Code	KI-985-L	KI-7652-P
Qty	x 4	x 2

NOTICE

1. Place the bearings equally on each side before attaching them.
2. Position the bearing support in such a way as to lock. (Image 1)
3. Firmly tighten the bearing support screws.

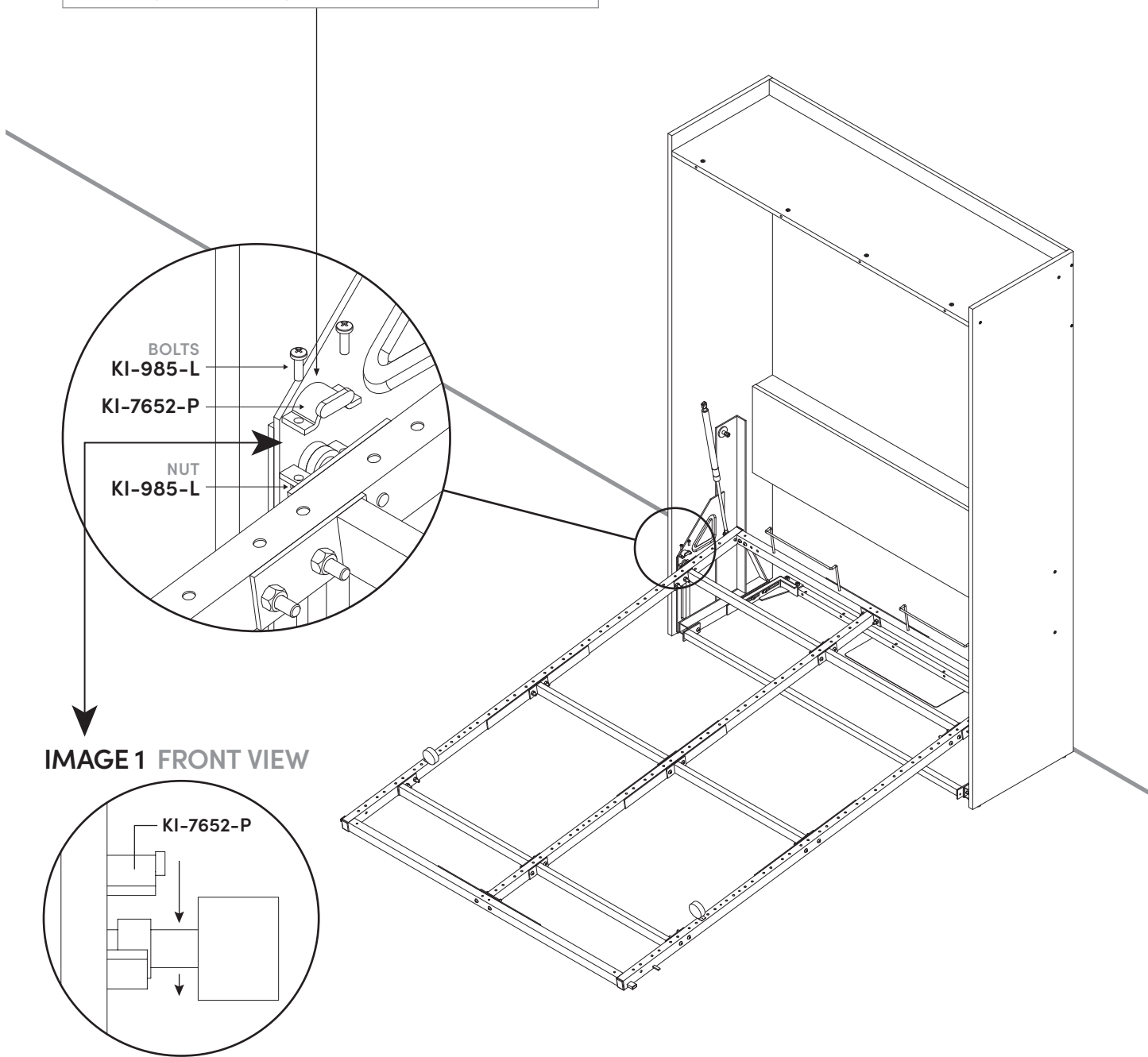
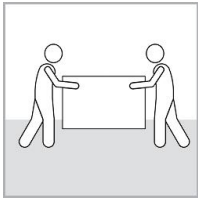

IMAGE 1 FRONT VIEW

Have an assembly question or need a replacement part? Just call 1-800-950-4782, we are here to help.

¿Tiene alguna pregunta sobre el montaje o necesita una pieza de repuesto? Simplemente llame al 1-800-950-4782, estamos aquí para ayudarle.

Vous avez une question concernant l'assemblage ou vous avez besoin d'une pièce de rechange? Appelez au 1-800-950-4782, nous sommes là pour vous aider.



Team Lift
Esfuerzo de equipo
Effort d'équipe

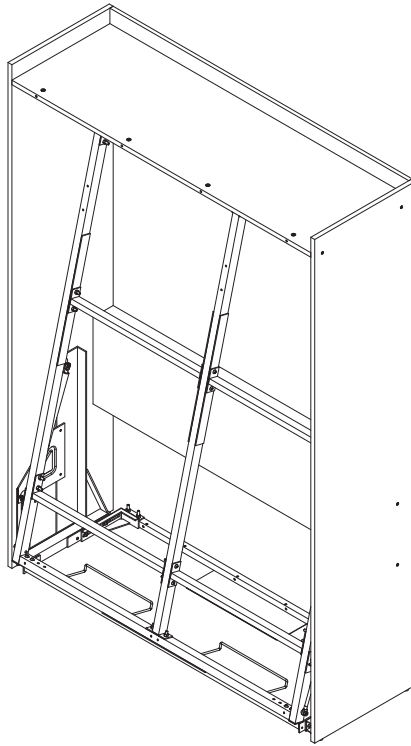

NOTICE

Take note that after the installation of the pistons, it will be very difficult to open the bed. Follow the steps until the end, after mattress and front panels are installed, the bed will open without effort.

INSERT CYLINDER ON ITS SUPPORT ROD

KI-7652-J must be completely tightened

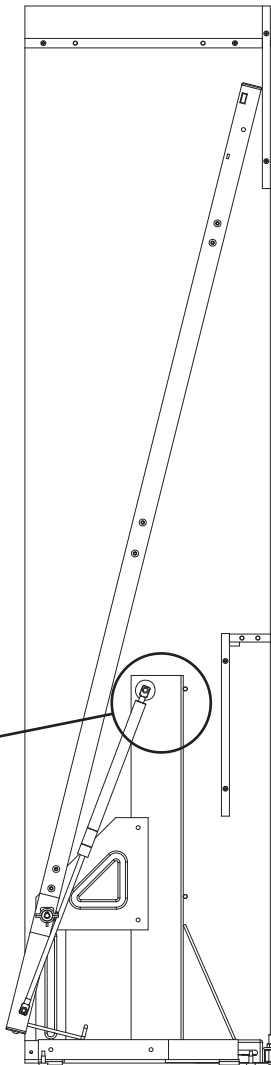
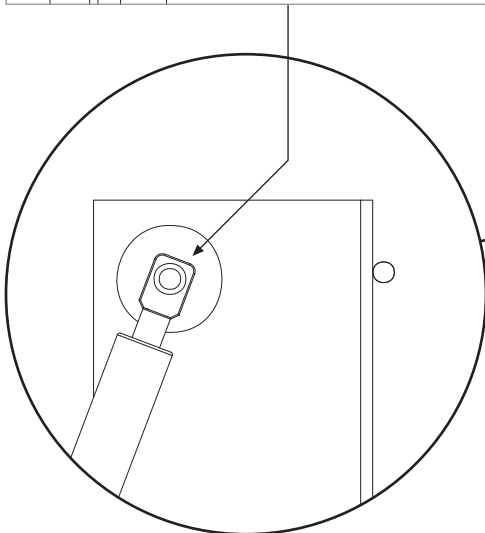
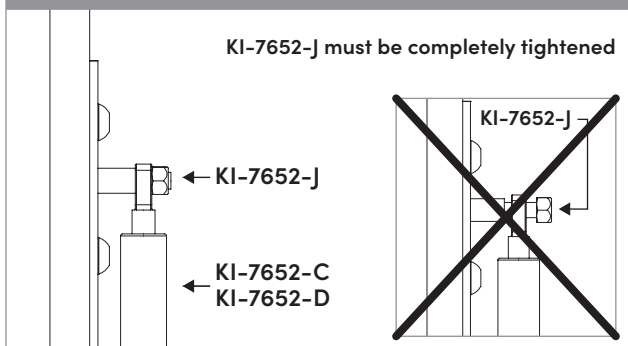

Have an assembly question or need a replacement part? Just call 1-800-950-4782, we are here to help.

¿Tiene alguna pregunta sobre el montaje o necesita una pieza de repuesto? Simplemente llame al 1-800-950-4782, estamos aquí para ayudarle.

Vous avez une question concernant l'assemblage ou vous avez besoin d'une pièce de rechange? Appelez au 1-800-950-4782, nous sommes là pour vous aider.

21 Hardware installation & assembly
Murphy bed

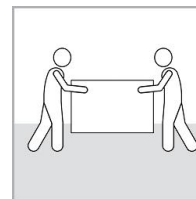

Team Lift
Esfuerzo de equipo
Effort d'équipe

Code	KI-985-G	KI-985-H	KI-985-I
Qty	x 1	x 1	x 1

NOTICE
Place an object so that the bed stays partially open.

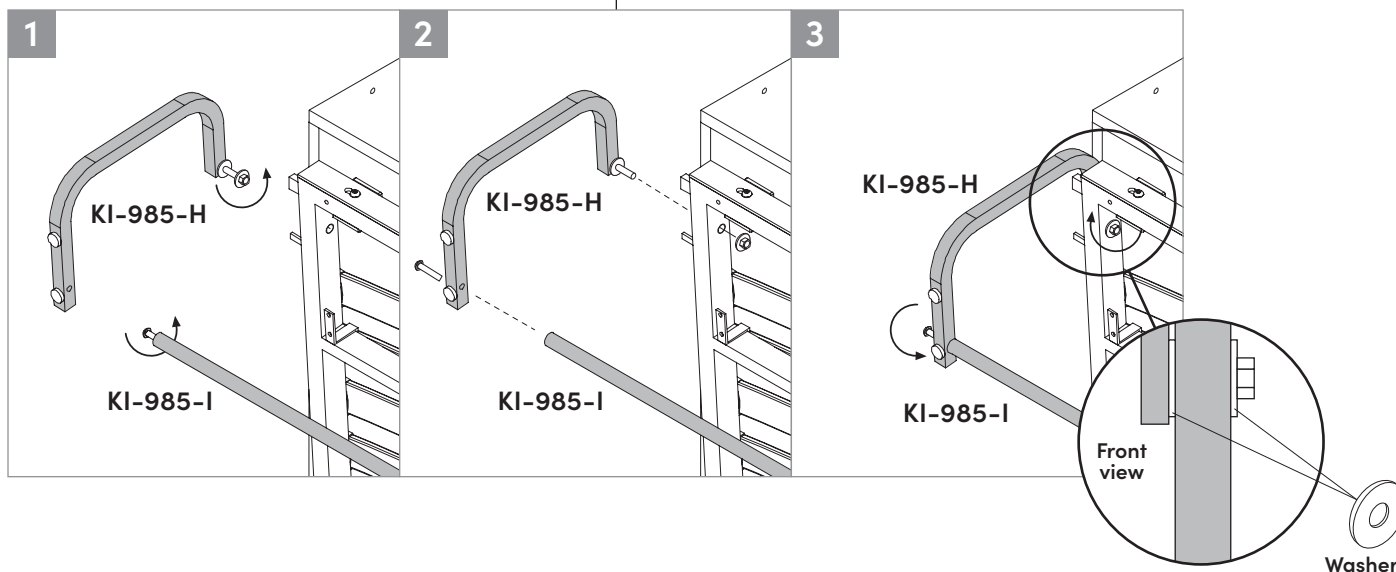
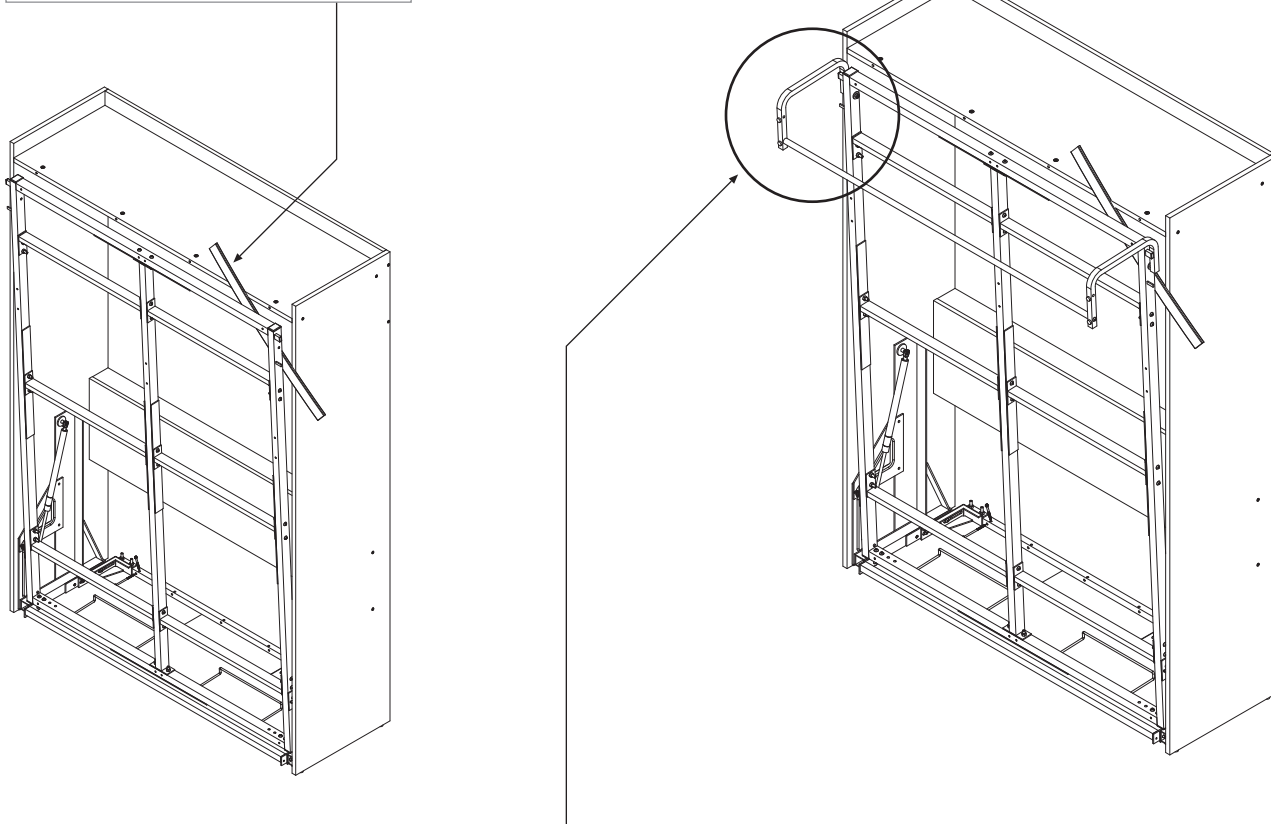

Have an assembly question or need a replacement part? Just call 1-800-950-4782, we are here to help.

¿Tiene alguna pregunta sobre el montaje o necesita una pieza de repuesto? Simplemente llame al 1-800-950-4782, estamos aquí para ayudarle.

Vous avez une question concernant l'assemblage ou vous avez besoin d'une pièce de rechange? Appelez au 1-800-950-4782, nous sommes là pour vous aider.

22 Hardware installation & assembly
Murphy bed

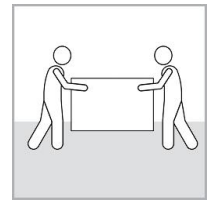

Team Lift
Esfuerzo de equipo
Effort d'équipe

Code	CA-7641	KI-7652-O	KI-7652-M	KI-7652-S	KI-7652-Y
Qty	x 2	x 4	x 6	x 2	x 2

Someone must hold the bed open during this step.

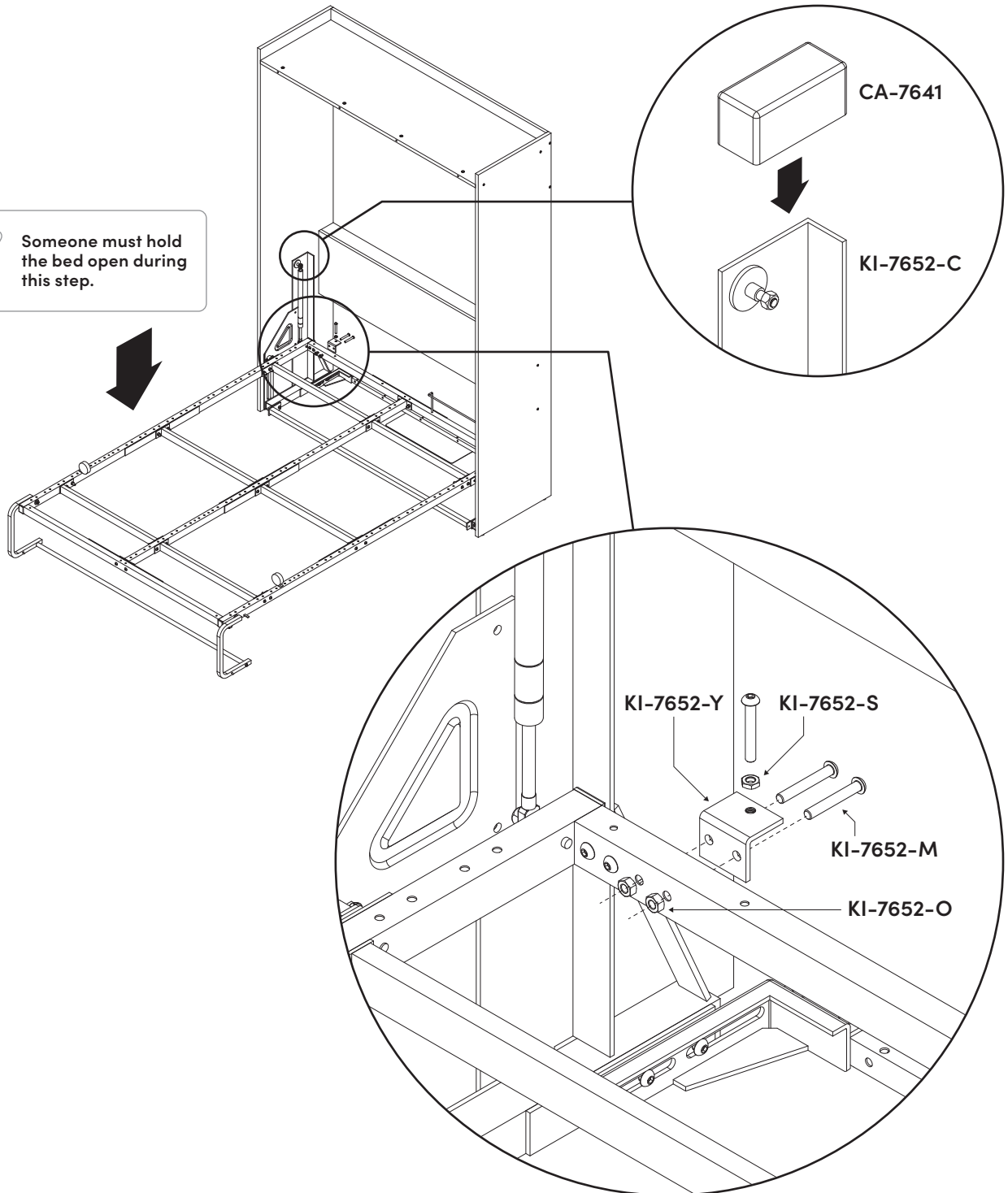

23 Assembly
Murphy bed

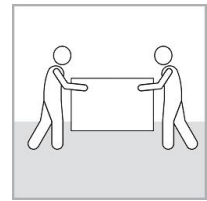

Team Lift
Esfuerzo de equipo
Effort d'équipe

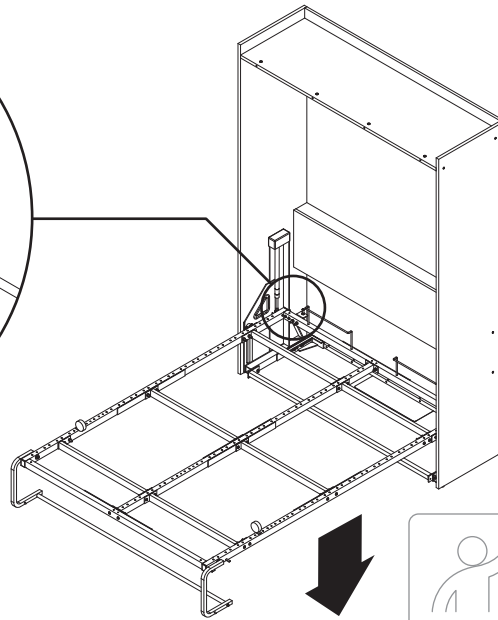
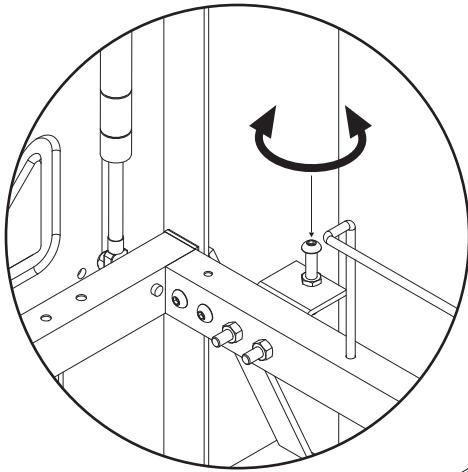

 Someone must hold the bed open during this step.

Adjustment
to close the metal base.

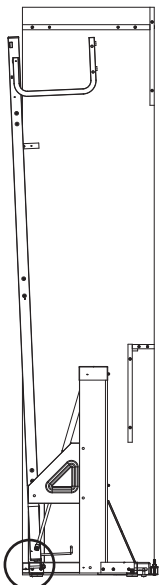

Adjustment
to open the metal base.

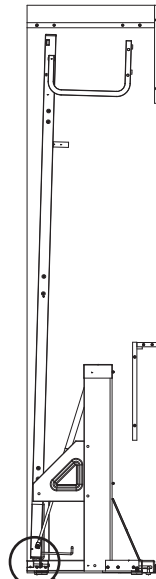

Perfect
adjustment.

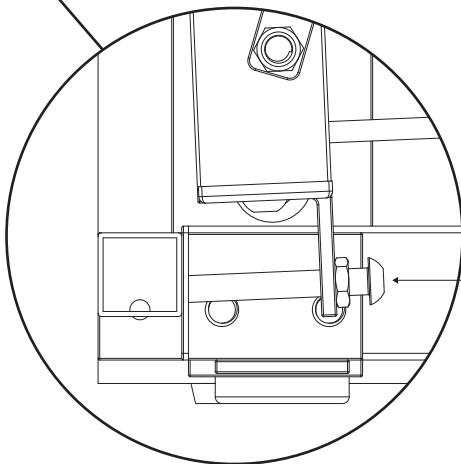
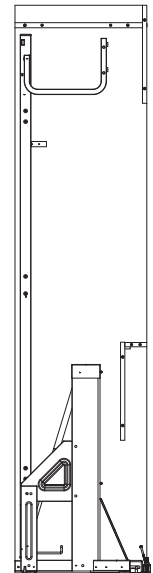

Unscrew
this bolt.

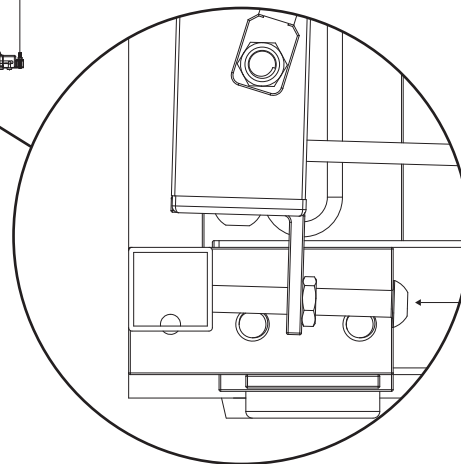

Screw
this bolt.

Have an assembly question or need a replacement part? Just call 1-800-950-4782, we are here to help.

¿Tiene alguna pregunta sobre el montaje o necesita una pieza de repuesto? Simplemente llame al 1-800-950-4782, estamos aquí para ayudarle.

Vous avez une question concernant l'assemblage ou vous avez besoin d'une pièce de rechange? Appelez au 1-800-950-4782, nous sommes là pour vous aider.

24 Hardware installation & assembly
Murphy bed

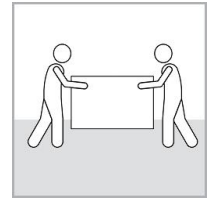

Team Lift
Esfuerzo de equipo
Effort d'équipe

Code	KI-985-S	KI-985-R	KI-7652-A-8	MA-1138
Qty	x 42	x 42	x 21	x 1

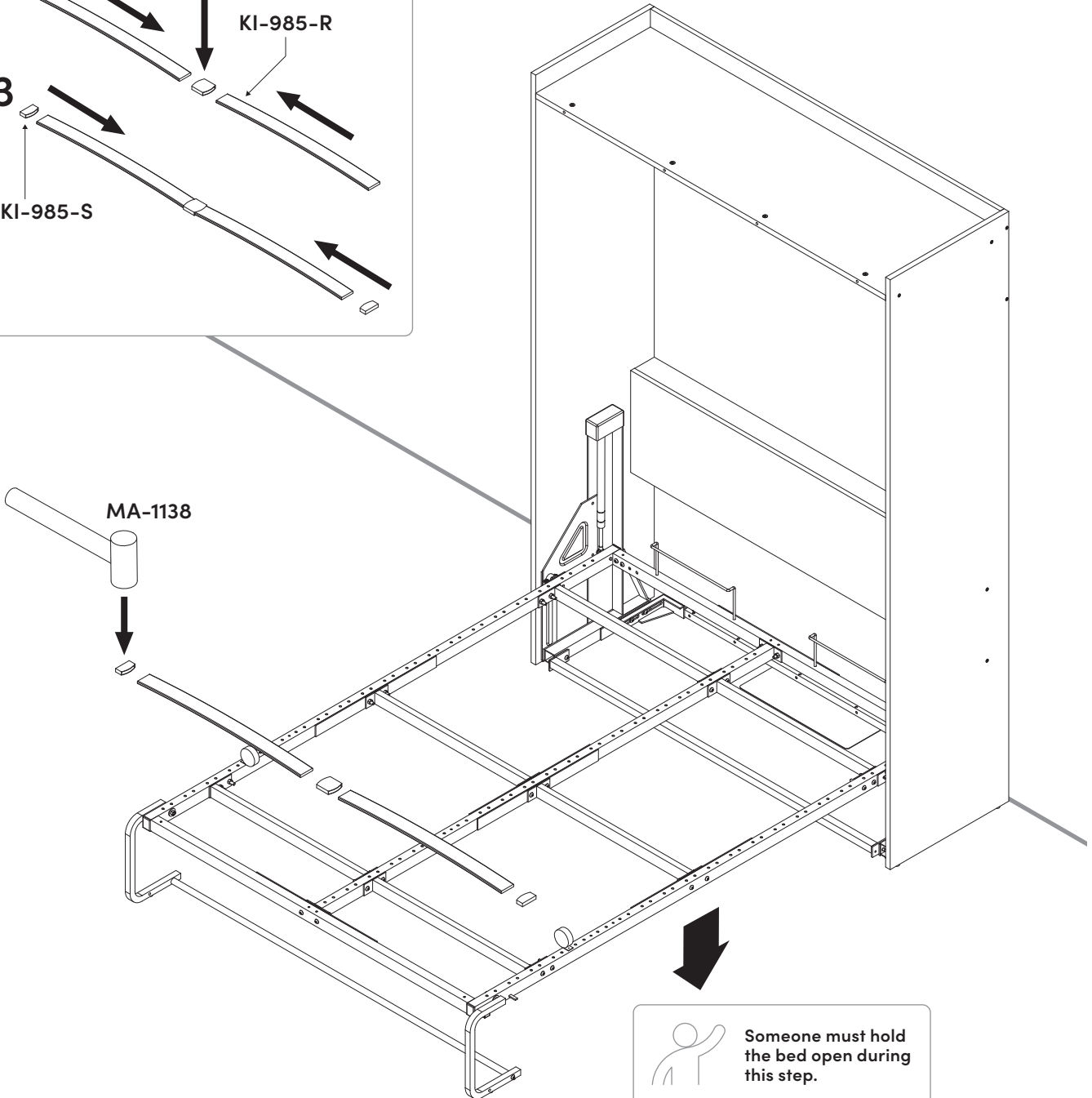
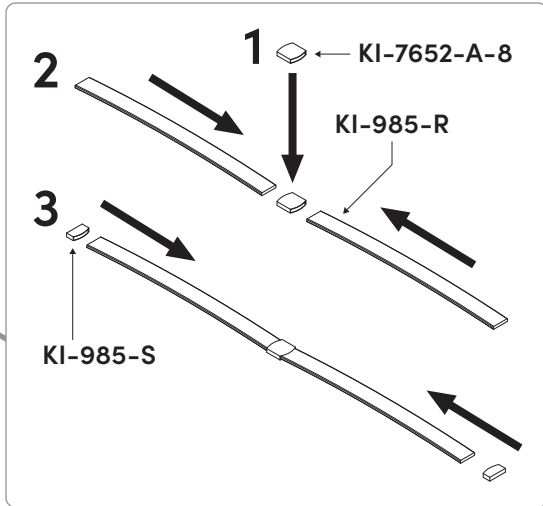

Have an assembly question or need a replacement part? Just call 1-800-950-4782, we are here to help.

¿Tiene alguna pregunta sobre el montaje o necesita una pieza de repuesto? Simplemente llame al 1-800-950-4782, estamos aquí para ayudarle.

Vous avez une question concernant l'assemblage ou vous avez besoin d'une pièce de rechange? Appelez au 1-800-950-4782, nous sommes là pour vous aider.

25 Hardware installation & assembly
Murphy bed

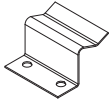

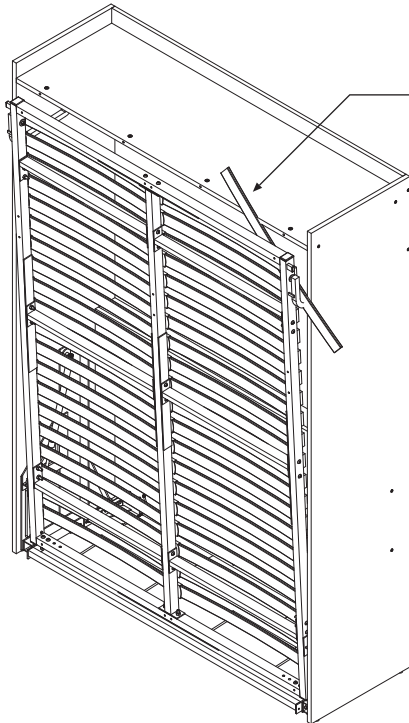

Code	CR-7639	3500-400350
Qty	x 3	x 6

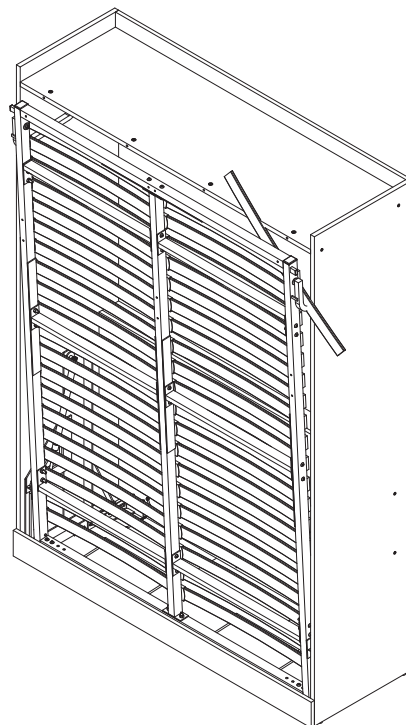
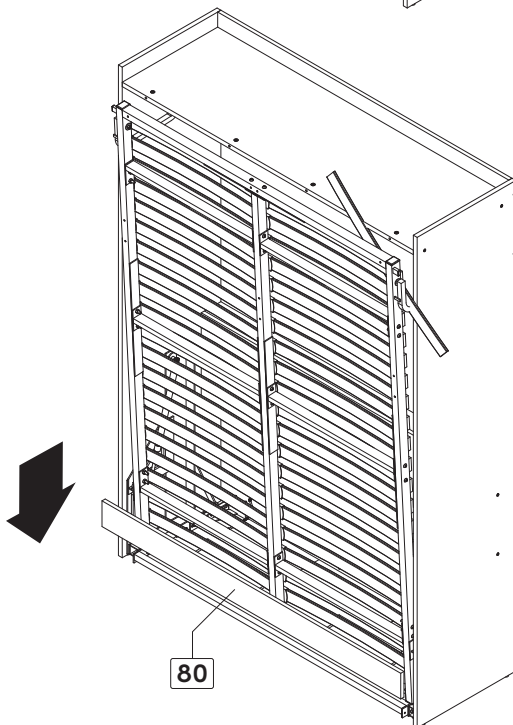
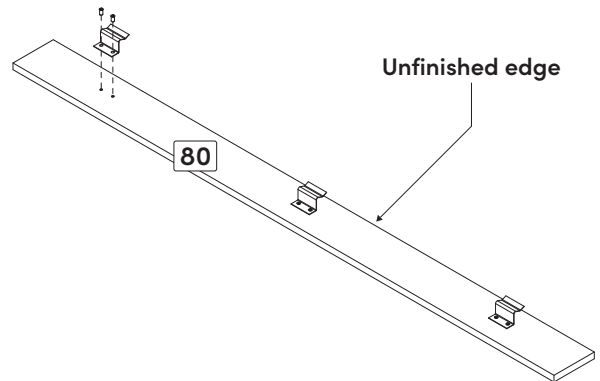

NOTICE
Place an object so that the bed stays partially open.

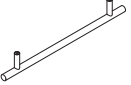

26 Hardware installation & assembly
Murphy bed

				
Code	KI-985-K	PO-959	VF-232	3500-400350
Qty	x 18	x 2	x 4	x 36

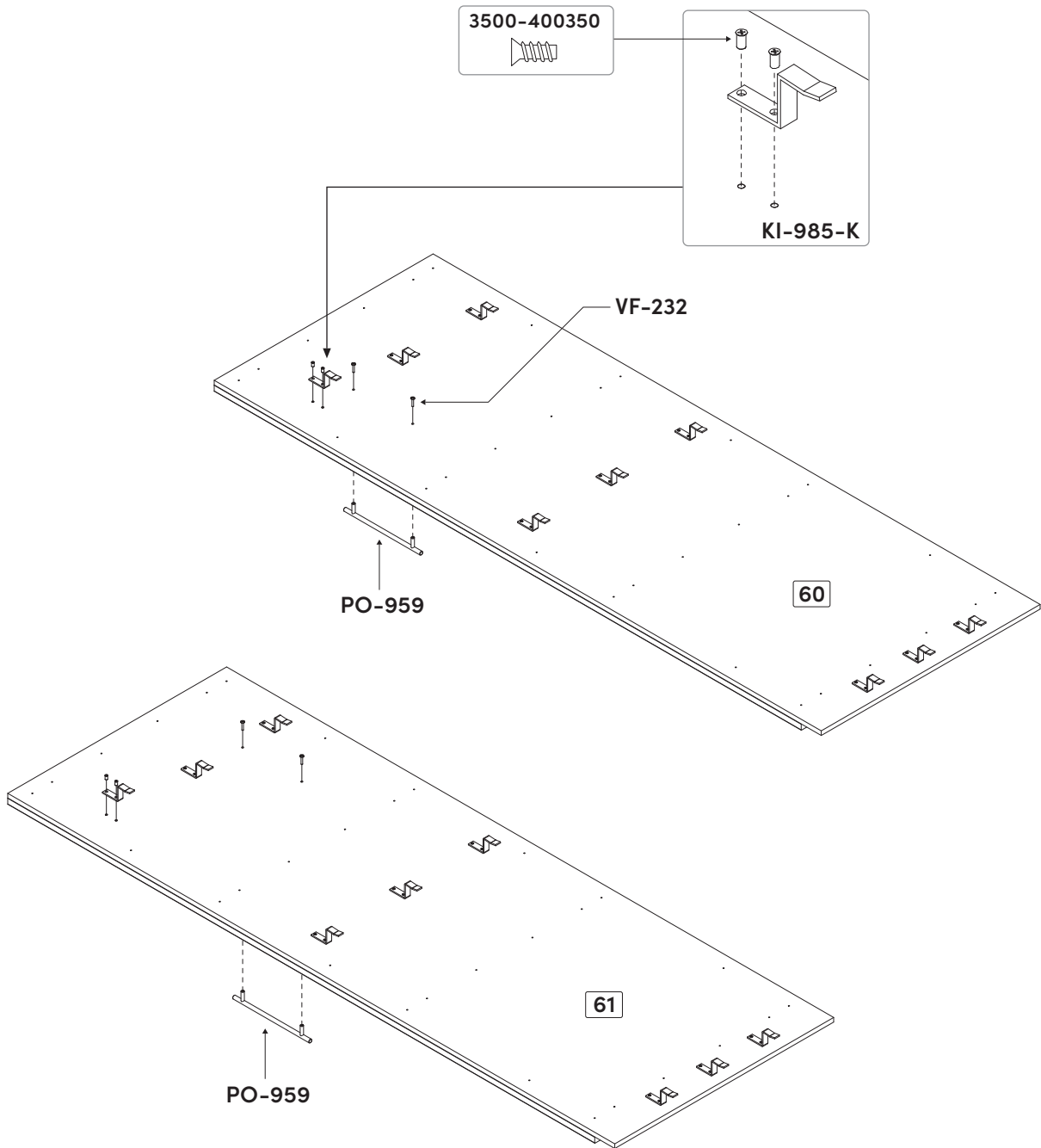

Have an assembly question or need a replacement part? Just call 1-800-950-4782, we are here to help.

¿Tiene alguna pregunta sobre el montaje o necesita una pieza de repuesto? Simplemente llame al 1-800-950-4782, estamos aquí para ayudarle.

Vous avez une question concernant l'assemblage ou vous avez besoin d'une pièce de rechange? Appelez au 1-800-950-4782, nous sommes là pour vous aider.

27 Hardware installation & assembly
Murphy bed

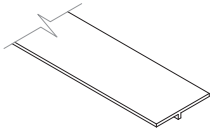

Code	EX-7635	VR-207
Qty	x 1	x 21

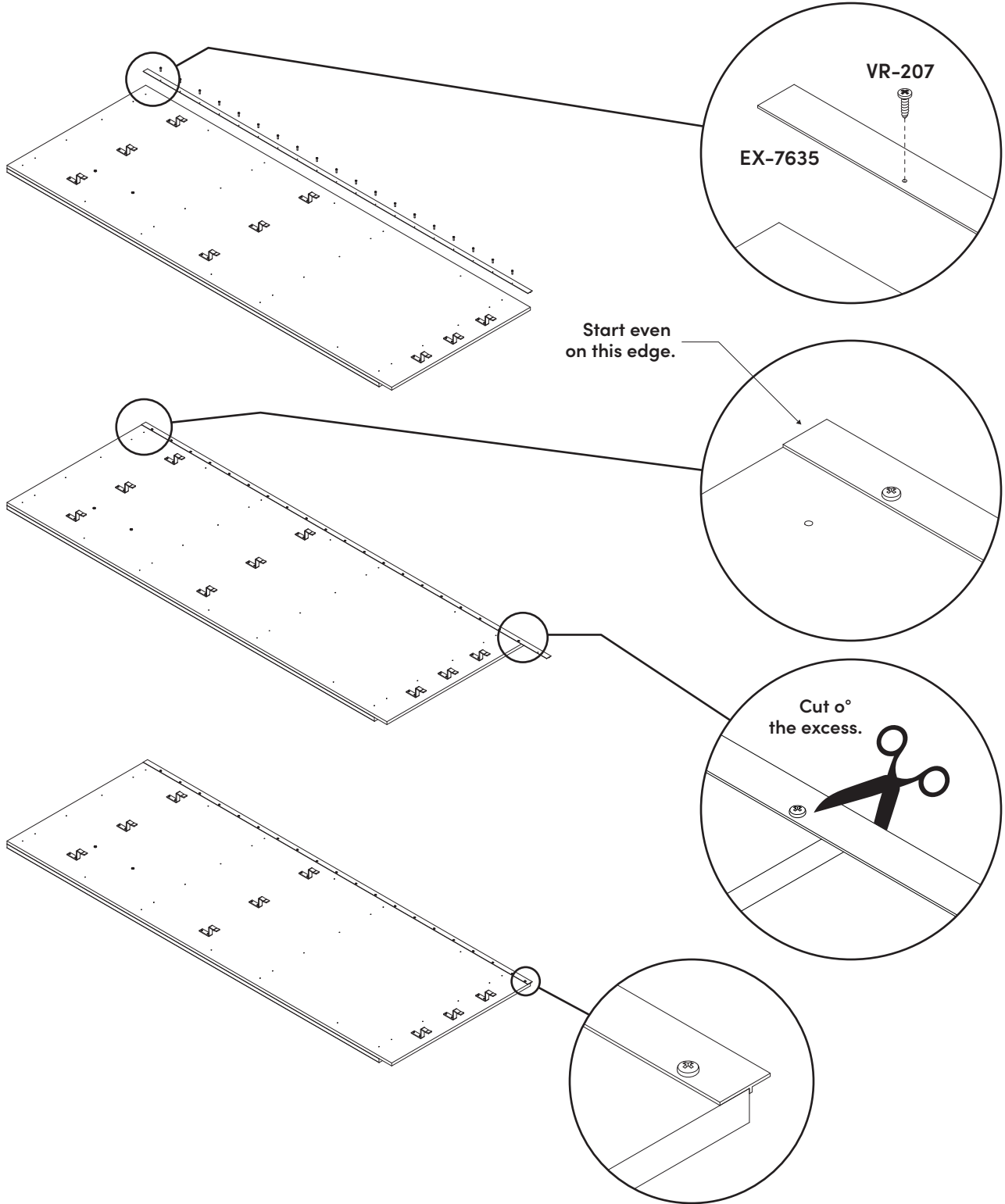

Have an assembly question or need a replacement part? Just call 1-800-950-4782, we are here to help.

¿Tiene alguna pregunta sobre el montaje o necesita una pieza de repuesto? Simplemente llame al 1-800-950-4782, estamos aquí para ayudarle.

Vous avez une question concernant l'assemblage ou vous avez besoin d'une pièce de rechange? Appelez au 1-800-950-4782, nous sommes là pour vous aider.

28 Hardware installation & assembly
Murphy bed

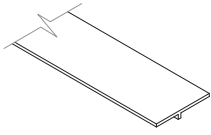

Code	EX-7635	VR-207
Qty	x 1	x 21

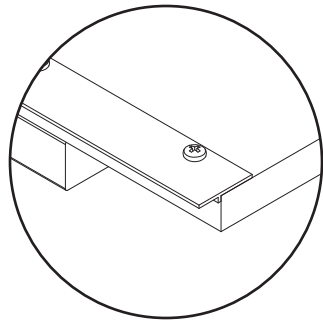
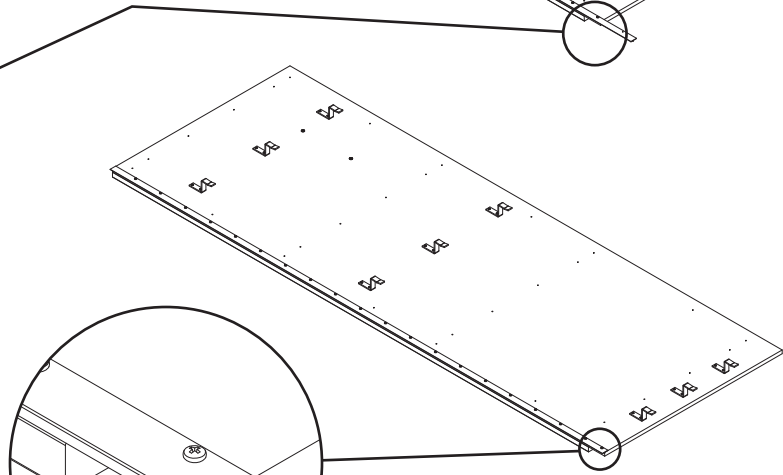
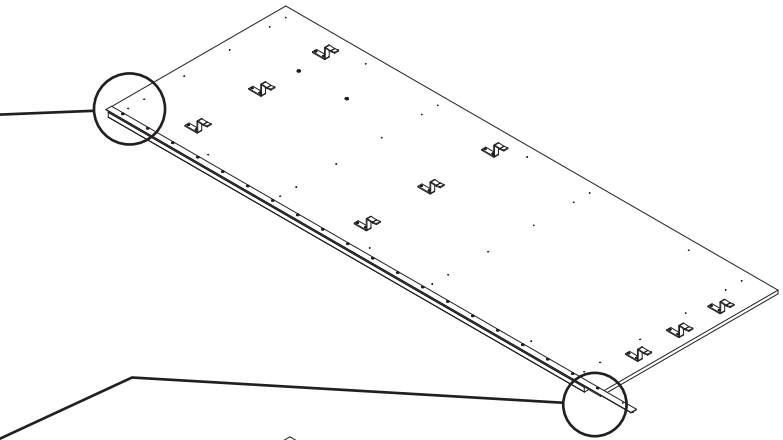
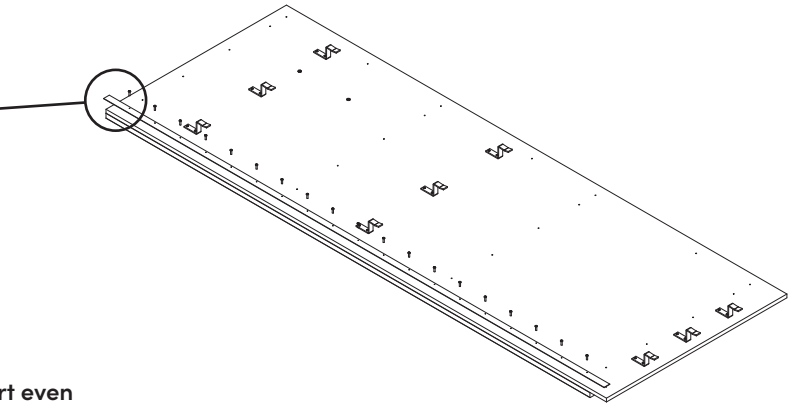
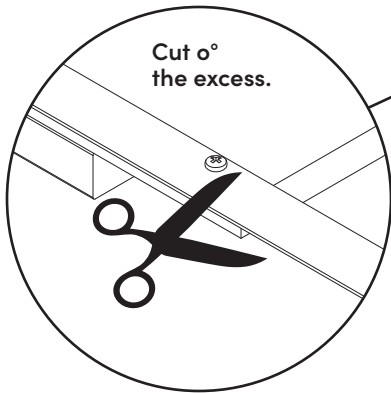
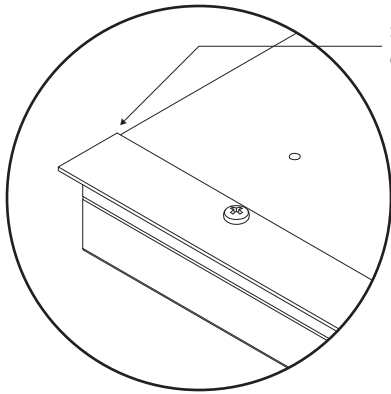
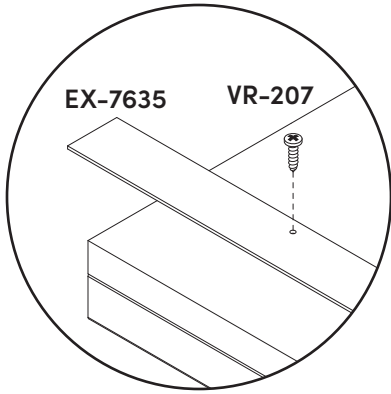

Have an assembly question or need a replacement part? Just call 1-800-950-4782, we are here to help.

¿Tiene alguna pregunta sobre el montaje o necesita una pieza de repuesto? Simplemente llame al 1-800-950-4782, estamos aquí para ayudarle.

Vous avez une question concernant l'assemblage ou vous avez besoin d'une pièce de rechange? Appelez au 1-800-950-4782, nous sommes là pour vous aider.

NOTICE

Use one of the cardboard corner pieces from packaging or similar object to keep the bed in semi-closed position for the installation of the facades.

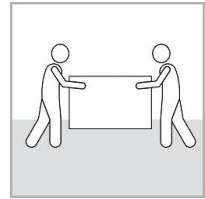

Team Lift
Esfuerzo de equipo
Effort d'équipe

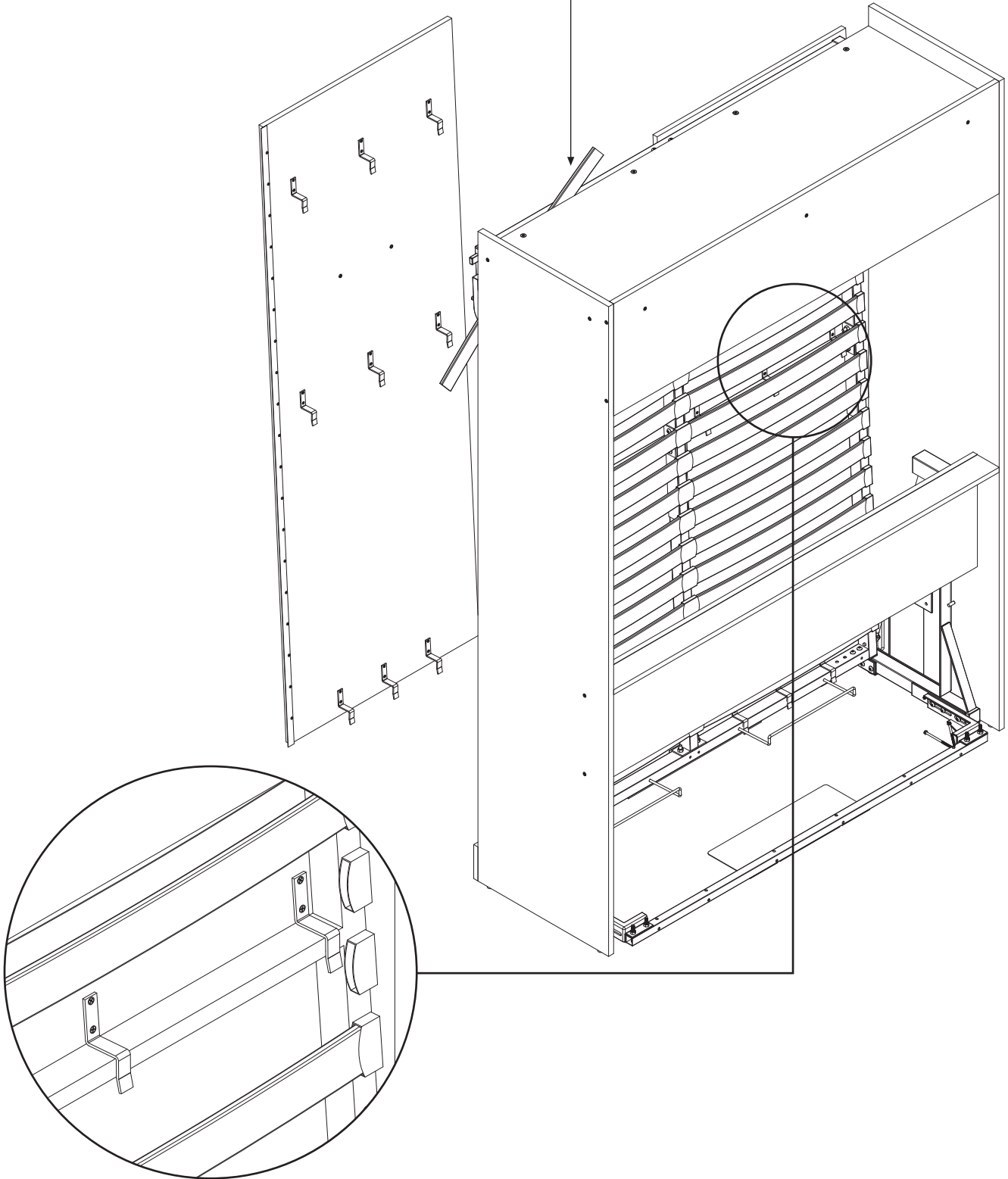

Have an assembly question or need a replacement part? Just call 1-800-950-4782, we are here to help.

¿Tiene alguna pregunta sobre el montaje o necesita una pieza de repuesto? Simplemente llame al 1-800-950-4782, estamos aquí para ayudarle.

Vous avez une question concernant l'assemblage ou vous avez besoin d'une pièce de rechange? Appelez au 1-800-950-4782, nous sommes là pour vous aider.

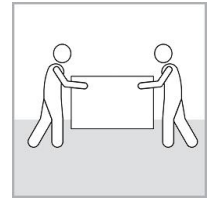

Team Lift
Esfuerzo de equipo
Effort d'équipe

Move the facades to the left or to the right
until the space is the same on each side.

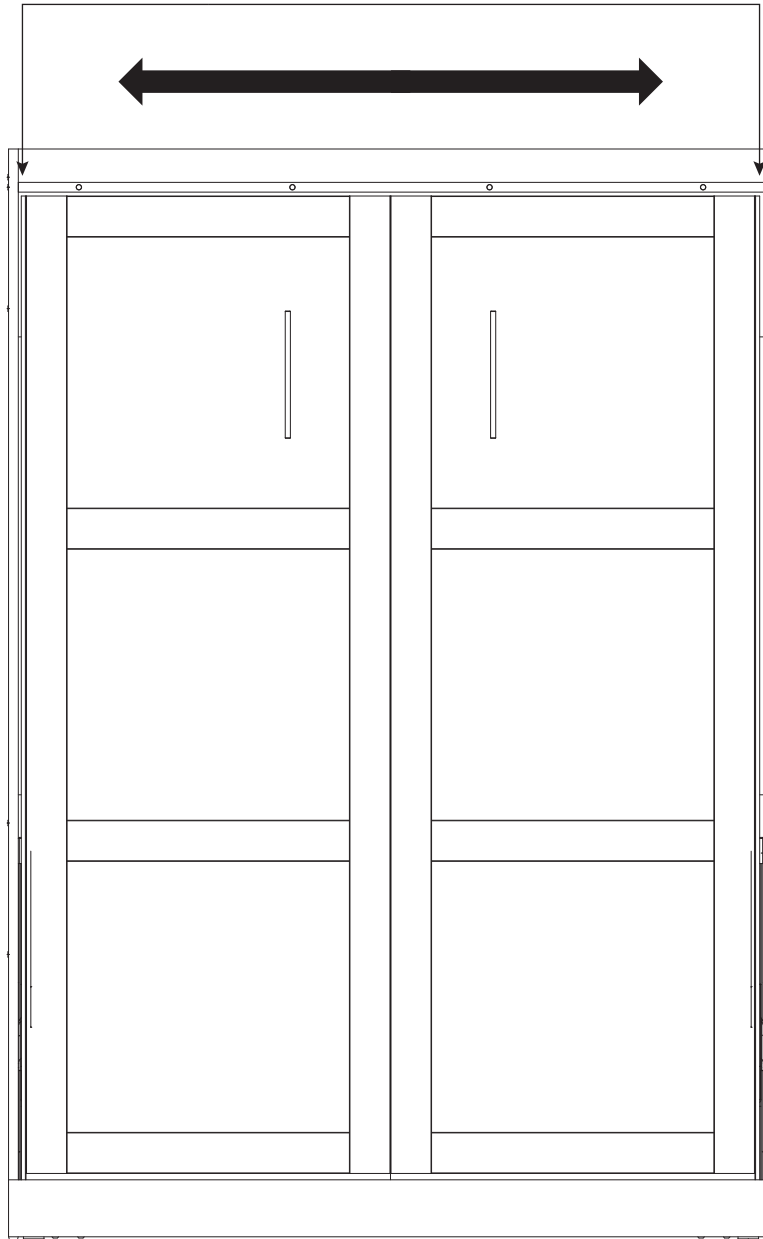

Have an assembly question or need a replacement part? Just call 1-800-950-4782, we are here to help.

¿Tiene alguna pregunta sobre el montaje o necesita una pieza de repuesto? Simplemente llame al 1-800-950-4782, estamos aquí para ayudarle.

Vous avez une question concernant l'assemblage ou vous avez besoin d'une pièce de rechange? Appelez au 1-800-950-4782, nous sommes là pour vous aider.

31 Hardware installation & assembly
Murphy bed

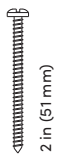

Code VR-215
Qty x 8

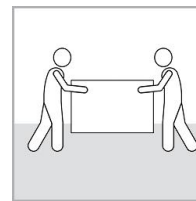

Team Lift
Esfuerzo de equipo
Effort d'équipe

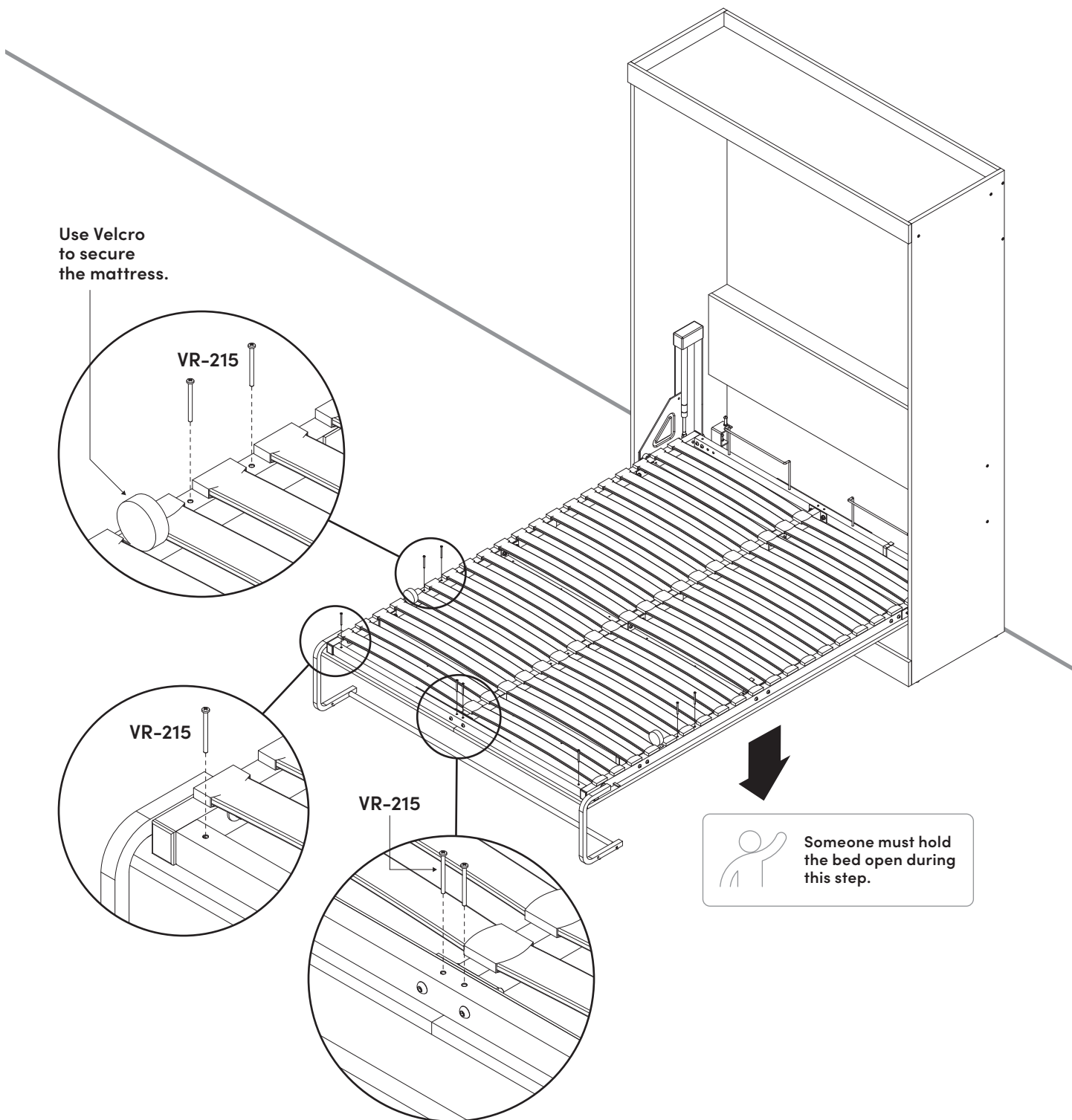

Have an assembly question or need a replacement part? Just call 1-800-950-4782, we are here to help.

¿Tiene alguna pregunta sobre el montaje o necesita una pieza de repuesto? Simplemente llame al 1-800-950-4782, estamos aquí para ayudarle.

Vous avez une question concernant l'assemblage ou vous avez besoin d'une pièce de rechange? Appelez au 1-800-950-4782, nous sommes là pour vous aider.

32 Hardware installation & assembly
Murphy bed

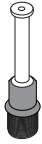

Code H-36
Qty x 4

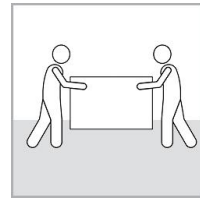

Team Lift
Esfuerzo de equipo
Effort d'équipe

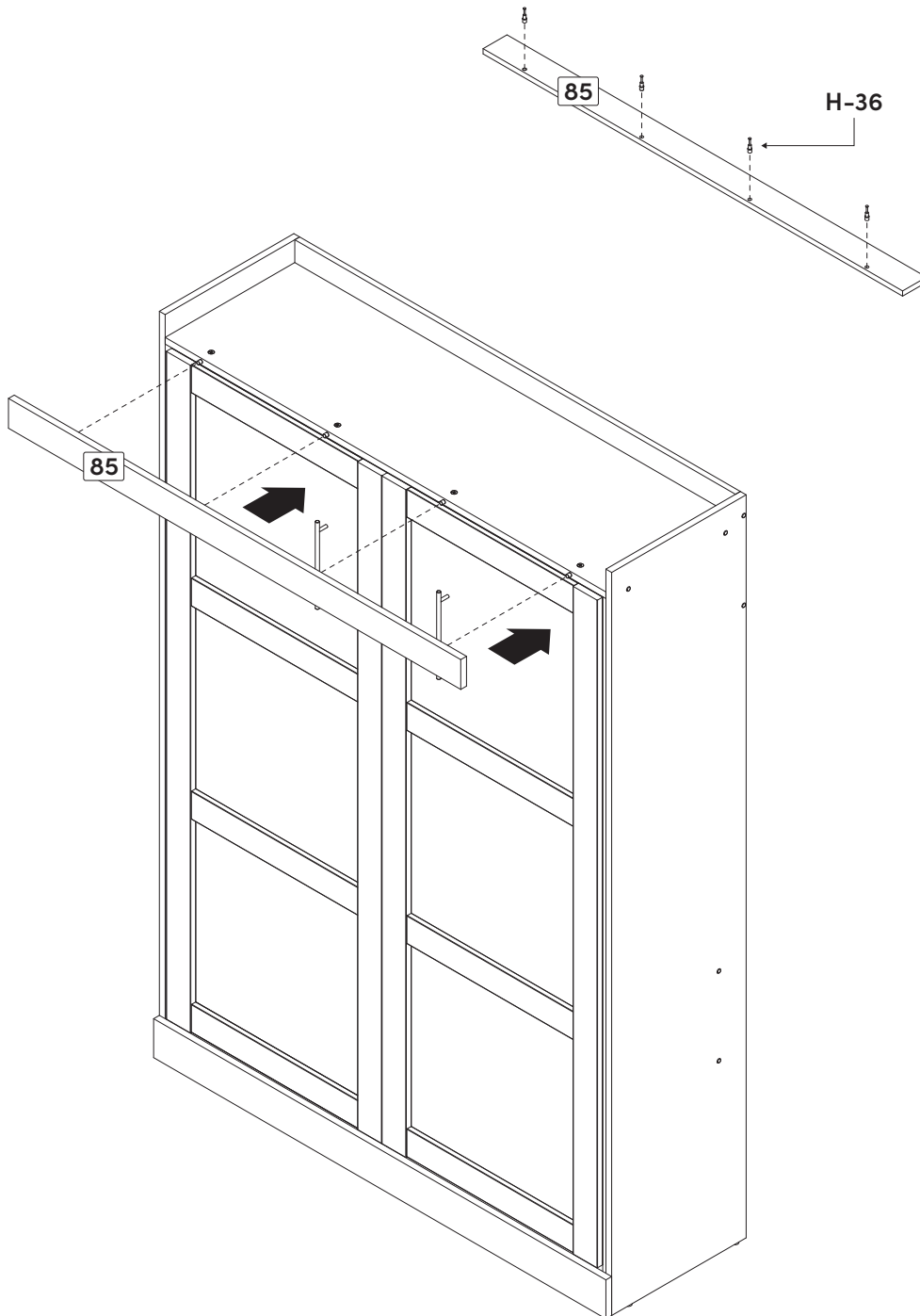

Have an assembly question or need a replacement part? Just call 1-800-950-4782, we are here to help.

¿Tiene alguna pregunta sobre el montaje o necesita una pieza de repuesto? Simplemente llame al 1-800-950-4782, estamos aquí para ayudarle.

Vous avez une question concernant l'assemblage ou vous avez besoin d'une pièce de rechange? Appelez au 1-800-950-4782, nous sommes là pour vous aider.



WARNING

RISK OF SERIOUS INJURY OR DEATH

- Never close the bed with a person on the mattress due to risk of suffocation.
- If the bed mechanism or a panel is damaged for any reason, please stop using the bed and contact us at 1-888-823-7827 to get the instructions and the parts required for the repair (if possible). Do not continue to use a damaged bed and don't try to fix it yourself without instructions from Bestar. A damaged bed may malfunction resulting in unexpected opening, closing, or collapse of bed.



WARNING

TO AVOID RISK OF FIRE

- Never close the bed with the lights on.
- Never leave an electric blanket or any other sources of heat inside the closed cabinet.



CAUTION

RISK OF INJURY

- Do not apply any items on the facade, such as picture frames, shelves, hooks or clothing. The facade may detach from the metal frame if it is overloaded.
- Do not leave anything on the bed which could prevent bed from closing properly. (pillows, decorative cushion, plush toys, etc.). This can cause damage to the bed, falling parts, and an unexpected opening of the bed that may cause injury.

NOTICE

- Always rotate leg down to support bed when opening. Failure to rotate the leg downward can result in panel or floor damage
- Always rotate the leg inward when closing bed to avoid damage.
- Never jump on the bed or leave a young child playing alone on the bed. This could cause the person to fall and could also damage the bed mechanism.

Have an assembly question or need a replacement part? Just call 1-800-950-4782, we are here to help.

¿Tiene alguna pregunta sobre el montaje o necesita una pieza de repuesto? Simplemente llame al 1-800-950-4782, estamos aquí para ayudarle.

Vous avez une question concernant l'assemblage ou vous avez besoin d'une pièce de rechange? Appelez au 1-800-950-4782, nous sommes là pour vous aider.

DISASSEMBLY

Important information to read before starting the disassembly.
Keep this information for future reference.



WARNING

IMPACT OR CRUSHING HAZARD: if wall attachment screws are removed before removing lift cylinders and metal mattress frame, wall bed cabinet can suddenly fall, resulting in serious injury or death.

- Only a professional or qualified person should disassemble or adjust a wall bed.
- Improper disassembly of the wall bed may result in bed detaching from the wall resulting in serious injury.
- Wall bed must remain attached to wall for the following disassembly steps (1-9).
- Qualified person must have the skills and tools necessary to locate wall studs, identify type of wall structure (wood, metal, masonry or other) and install screws correctly to wall structure. Skills and tools include electronic stud finder, drill motor and bits, screwdriver, and ability to correctly use these tools.

1 Remove the mattress.

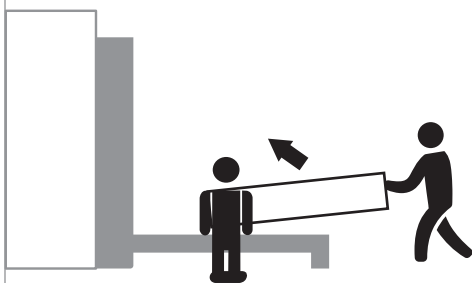

NOTICE

- By removing the mattress, the bed frame will rise quickly.
- Have a helper hold the frame down while removing the mattress.



Team Lift
Esfuerzo de equipo
Effort d'équipe

2 Remove the slats.

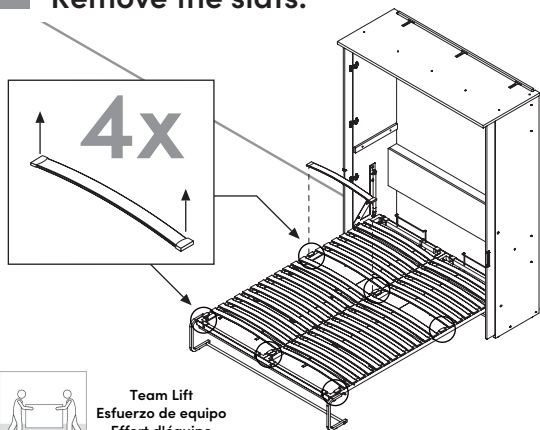

3 Unscrew the facades (screws VR-215).

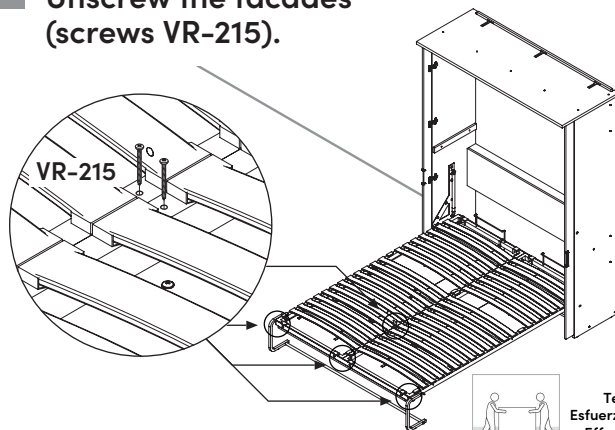

Have an assembly question or need a replacement part? Just call 1-800-950-4782, we are here to help.

¿Tiene alguna pregunta sobre el montaje o necesita una pieza de repuesto? Simplemente llame al 1-800-950-4782, estamos aquí para ayudarle.

Vous avez une question concernant l'assemblage ou vous avez besoin d'une pièce de rechange? Appelez au 1-800-950-4782, nous sommes là pour vous aider.

DISASSEMBLY

4 Rotate the leg toward the interior.

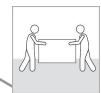
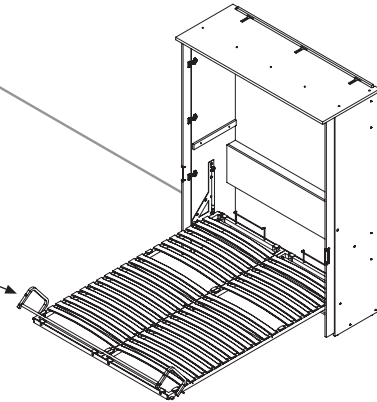
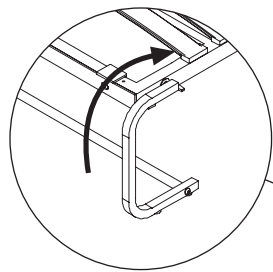

Team Lift
Esfuerzo de equipo
Effort d'équipe

5 Use an object of about 2 in (50 mm) thick to keep the bed in a semi-closed position, then lift and pull to remove the facades.

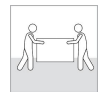
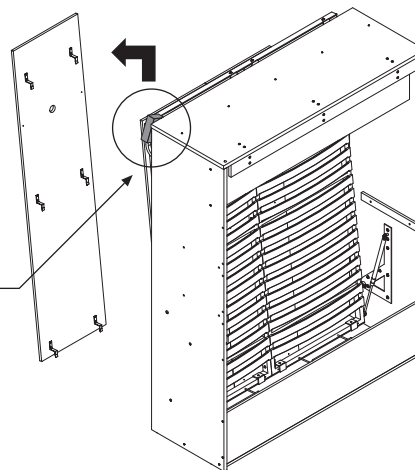
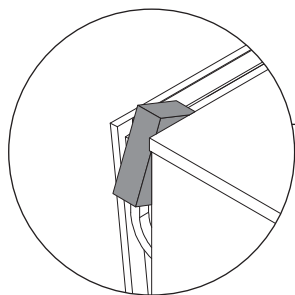

Team Lift
Esfuerzo de equipo
Effort d'équipe

6 Remove the stopper.

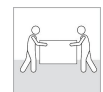
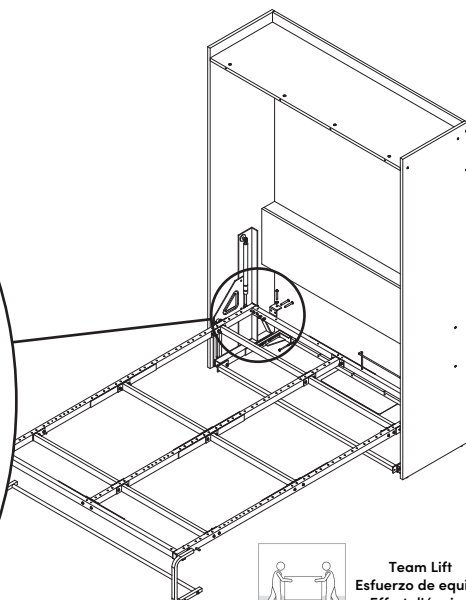
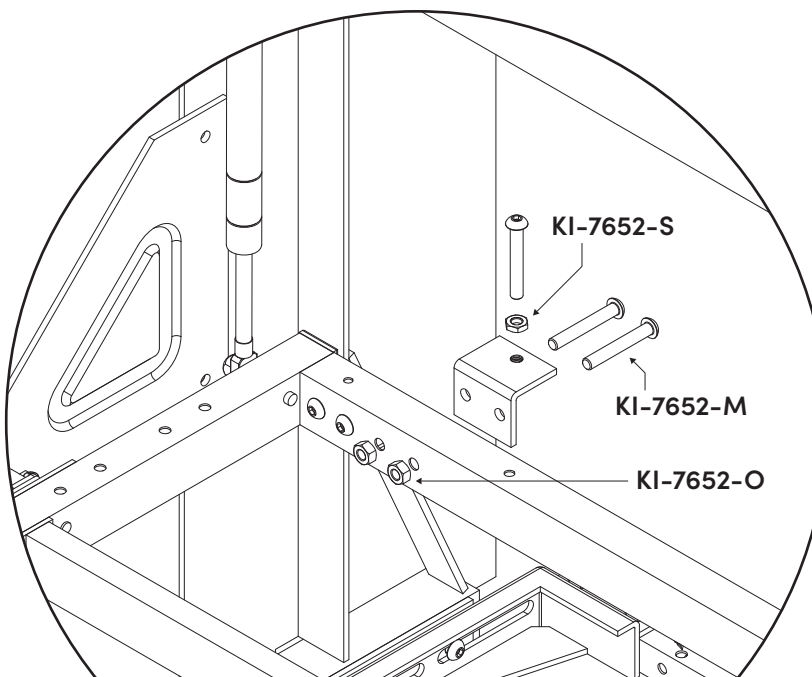

Team Lift
Esfuerzo de equipo
Effort d'équipe

Have an assembly question or need a replacement part? Just call 1-800-950-4782, we are here to help.

¿Tiene alguna pregunta sobre el montaje o necesita una pieza de repuesto? Simplemente llame al 1-800-950-4782, estamos aquí para ayudarle.

Vous avez une question concernant l'assemblage ou vous avez besoin d'une pièce de rechange? Appelez au 1-800-950-4782, nous sommes là pour vous aider.

- 7** Let the bed frame sink back into the cabinet and remove the lift cylinders.

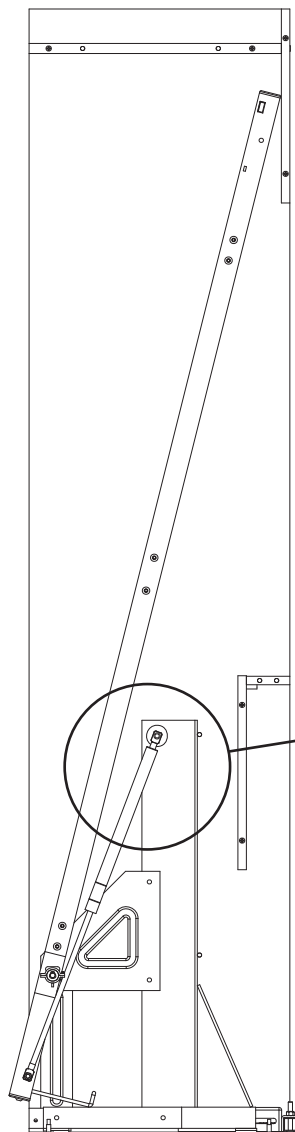

UNSCREW THE FASTENER AND REMOVE THE END OF THE CYLINDER FROM THE "L" BRACKET.

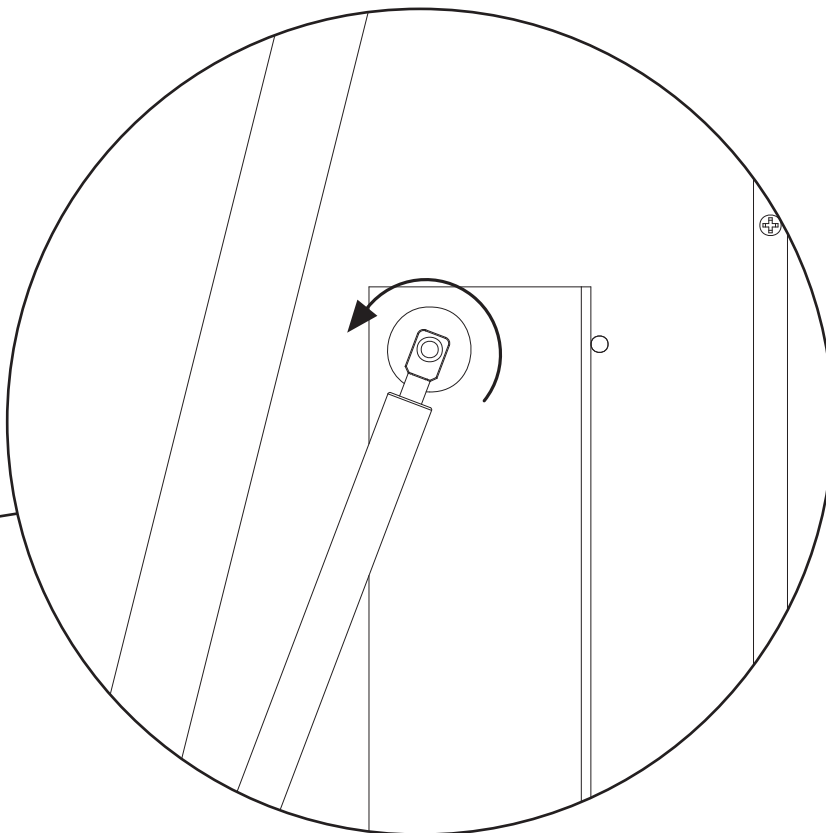

Have an assembly question or need a replacement part? Just call 1-800-950-4782, we are here to help.

¿Tiene alguna pregunta sobre el montaje o necesita una pieza de repuesto? Simplemente llame al 1-800-950-4782, estamos aquí para ayudarle.

Vous avez une question concernant l'assemblage ou vous avez besoin d'une pièce de rechange? Appelez au 1-800-950-4782, nous sommes là pour vous aider.

DISASSEMBLY

8 Unscrew and remove the bearing supports.

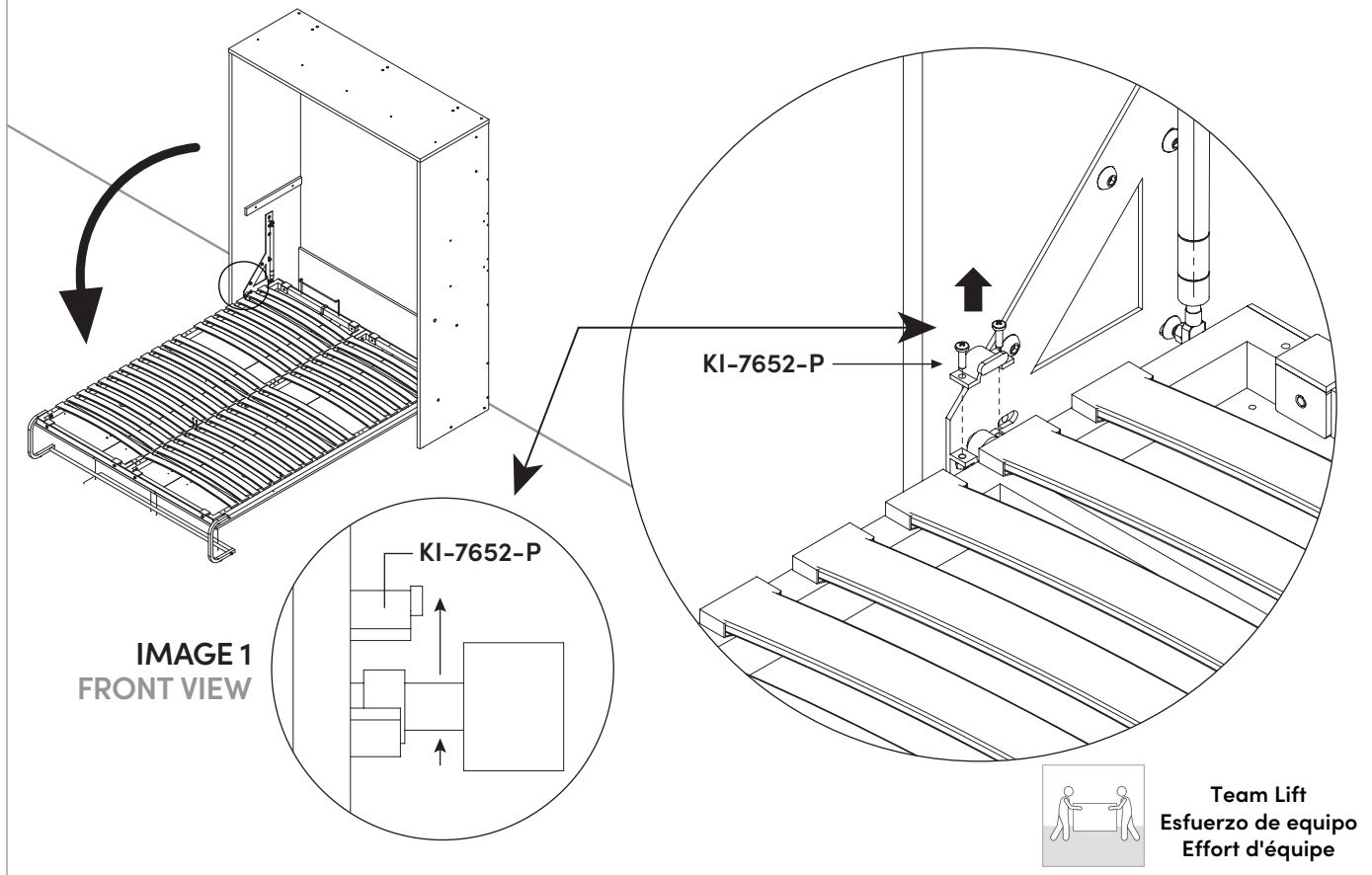

9 Lift the metal bed frame from the brackets.

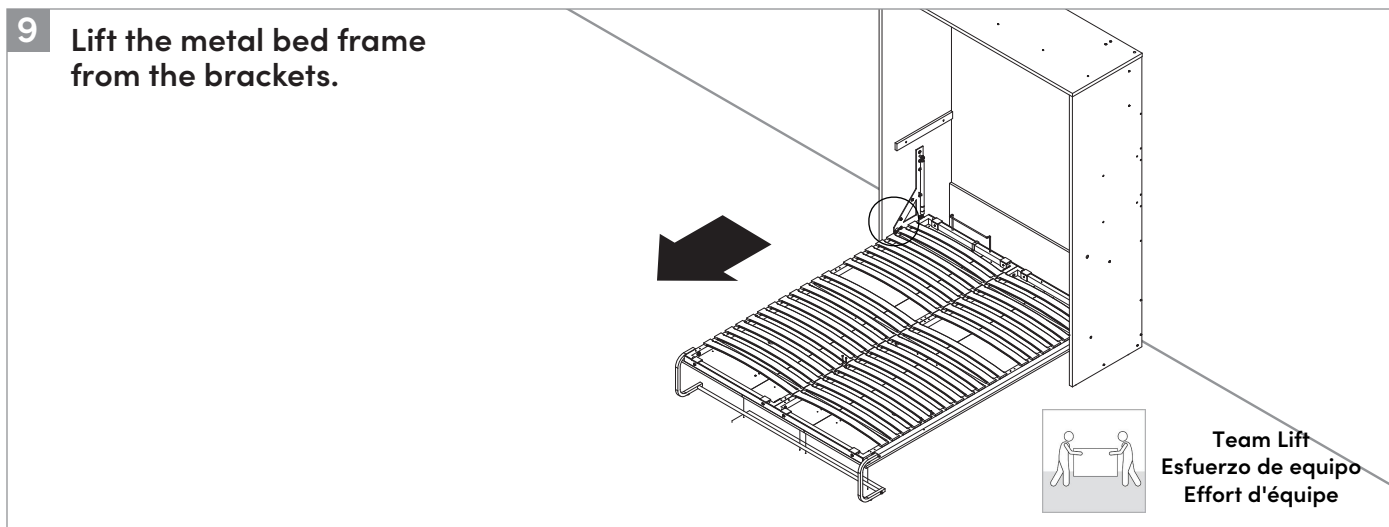

10 Now you can unscrew the bed from the wall and continue the disassembly.