

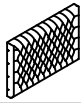

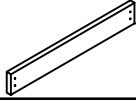

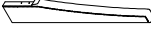

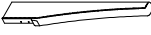



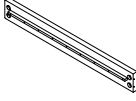
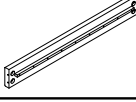
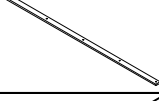
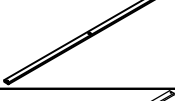
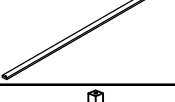





Q/F

PART LIST

Part No.	Description	Image	Quantity
A	Headboard		1PC
B	Footboard		1PC
C	Right Ear Panel		1PC
D	Left Ear Panel		1PC
E	Legs		2PCS
F	Right Side rail		1PC
G	Left Side rail		1PC
H	Center Rail		1PC
I	Slats Whit Hole		5PCS
J	Slats		8PCS
K	Slat Support Legs		5PCS
L	Ear Support		2PCS

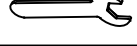
HARDWARE LIST

Part No.	Description	Image	Quantity
1	Bolt $\varnothing 5/16"$ x 1-1/2"		8PCS
2	Bolt $\varnothing 1/4"$ x 2-1/4"		9PCS
3	Screw M4 x 1-3/16"		26PCS
4	Lock Washer $\varnothing 5/16"$		8PCS
5	Flat Washer $\varnothing 5/16"$		8PCS
6	Lock Washer $\varnothing 1/4"$		9PCS
7	Flat Washer $\varnothing 1/4"$		9PCS
8	Bolt $\varnothing 5/16"$ * 3"		8PCS
9	Nut 5/16"		8PCS
10	Curved Washer		8PCS
11	Wrench 5/16"		1PC
12	Allen Wrench M4		1PC
13	Anti Slip Sheet		2PCS

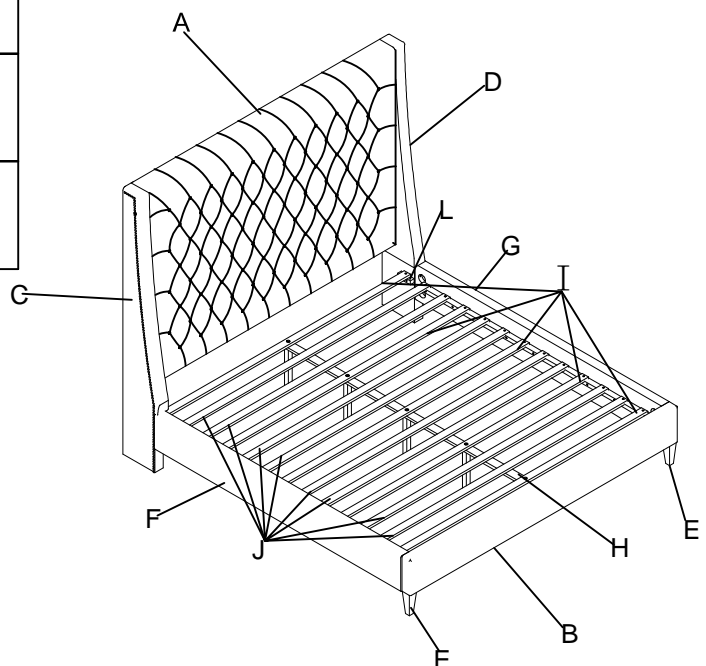

STEP 1

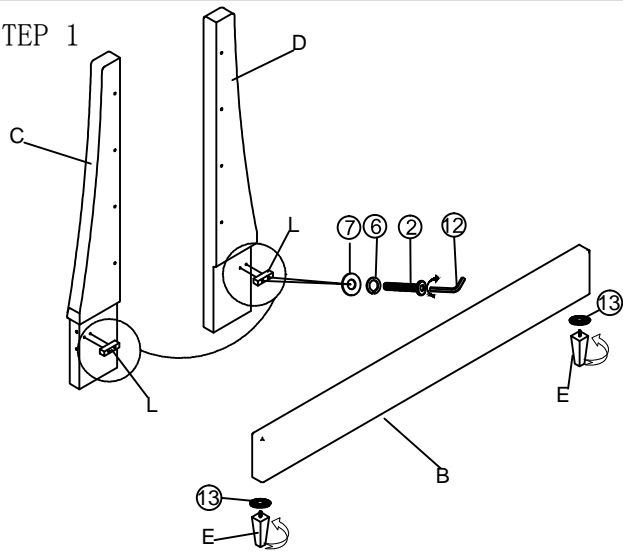

Notice: Assembly the taped wood leg with plastic ring into Headboard/Footboard bottom. Be tighten and keep the wood leg direction aline with headboard/Footboard. See illustration and Simple drawing.

STEP 2

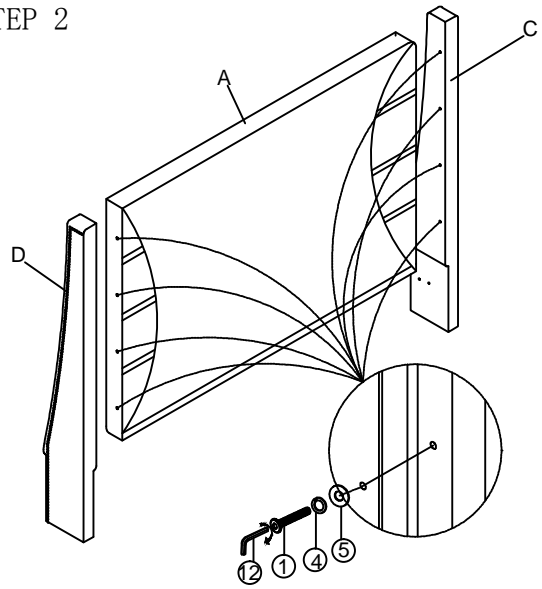

STEP 3

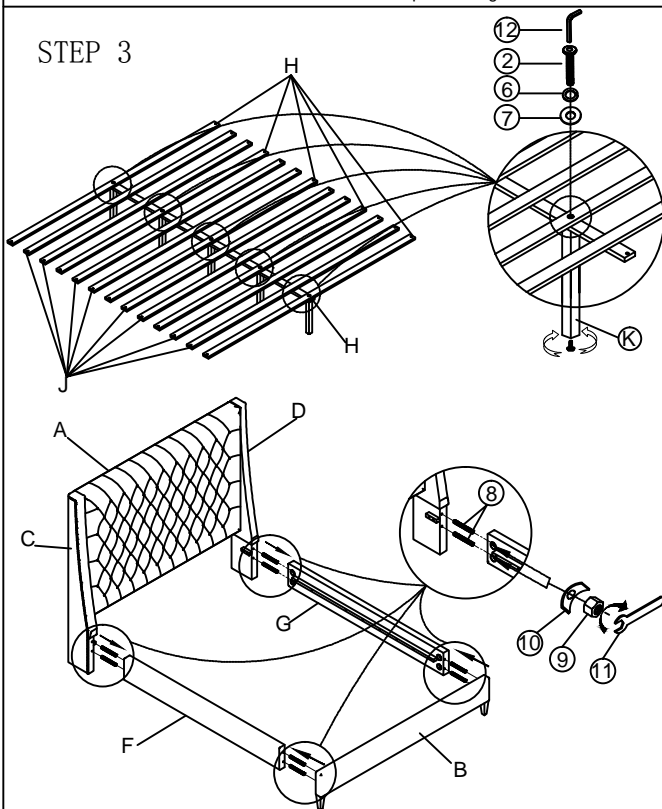

STEP 4

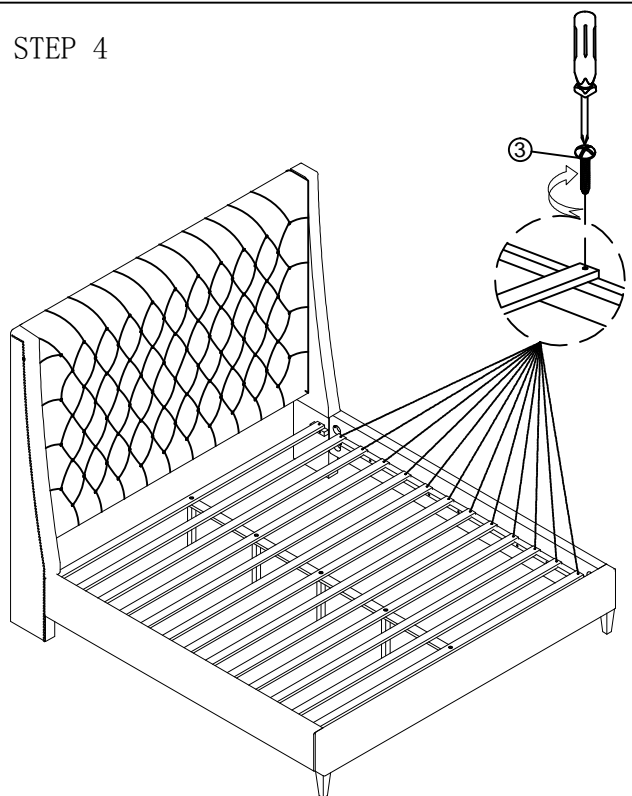

STEP 5

