

HG-WWHYR-4779 自动平开门电动机 说明书翻译

英

INSTALLATION MANUAL

DSW-100N

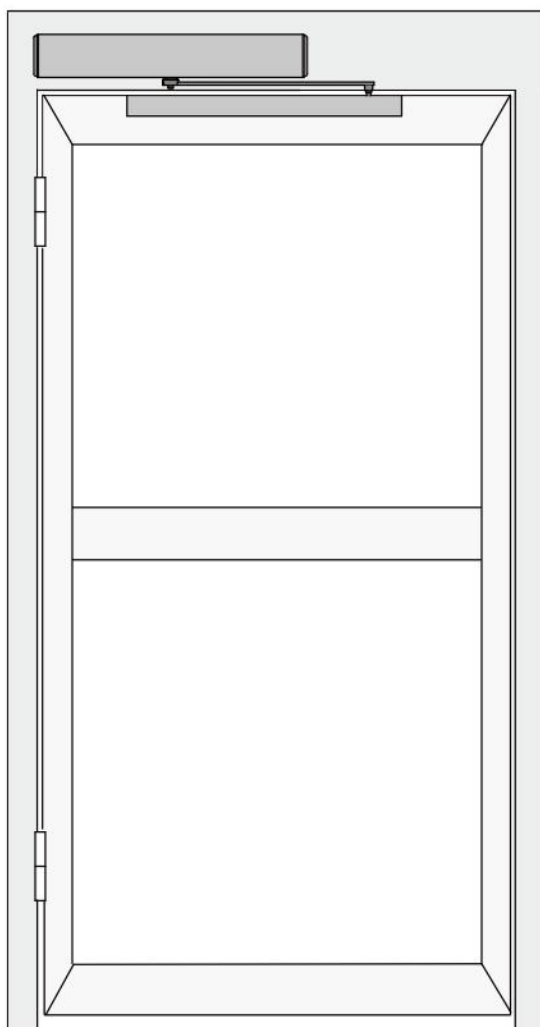

AUTOMATIC ENTRANCE SPECIALISTS

Contents

1. Technical Parameters	1
2. Components	2
3. Installation.....	3-10
3.1 Installation Example	3
3.2 Installation of Base Plate	4-5
3.3 Installation of Pull Arm	6
3.4 Installation of Push Arm	7-8
3.5 Installation of Operation System	9
3.6 Installation of Cover	9
3.7 Connection of Operation System and Pull Arm	10
3.8 Connection of Operation System and Push Arm.....	10
4. Electrical Connections	11-15
5. Parameters Adjustment	16

1. Technical Parameters

Voltage: 110~220V \pm 10%

Power consumption: 50W

Opening time: 3~7s/90°

Hold open time: 1~30s

Max. door frame depth: 450mm

Door width: Min. 660mm / Max. 1200mm

Max. opening angle: 120°

Environment Temperature: -20°C ~+50°C

Protection class: IP12D

Product weight: 6.5Kg

Dimension: L540xH95xW82mm

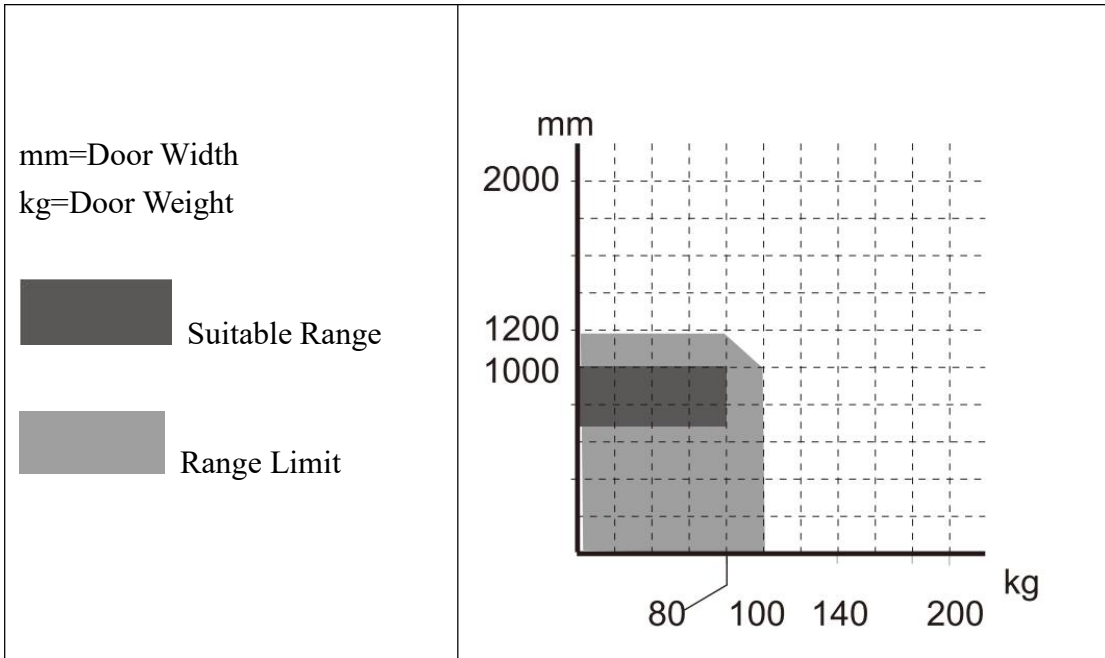

2. Components

hole for power cable

hole for sensor cable



base plate

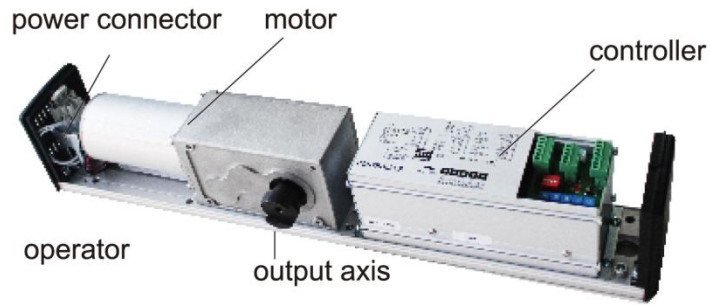

power connector

motor

controller

operator

output axis



cover



pull arm(alternative)
Inward opening



push arm(alternative)
Outward opening

3. Installation

3.1 Installation example

Choose pull arm: door leaf opens toward inside (operator is inside)

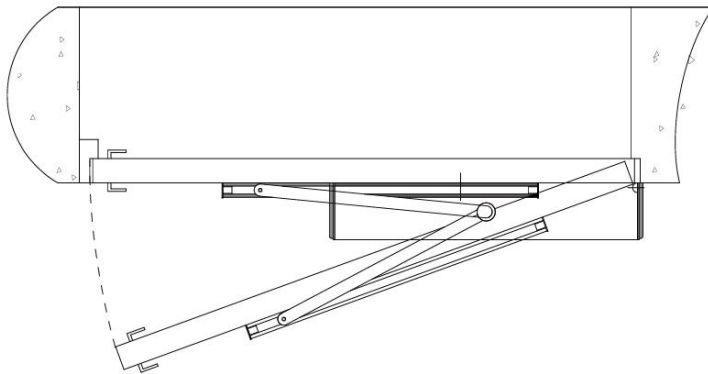
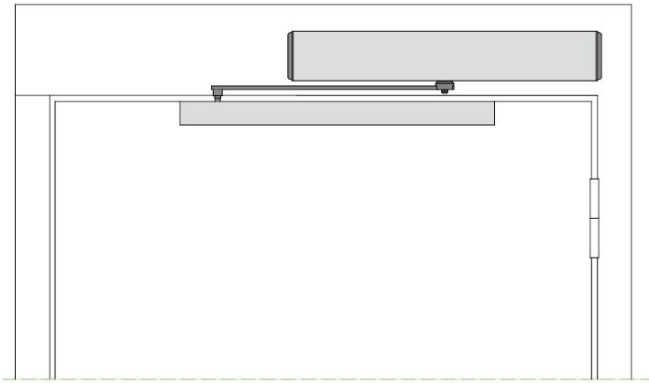

Choose push arm: door leaf opens toward outside (operator is inside)

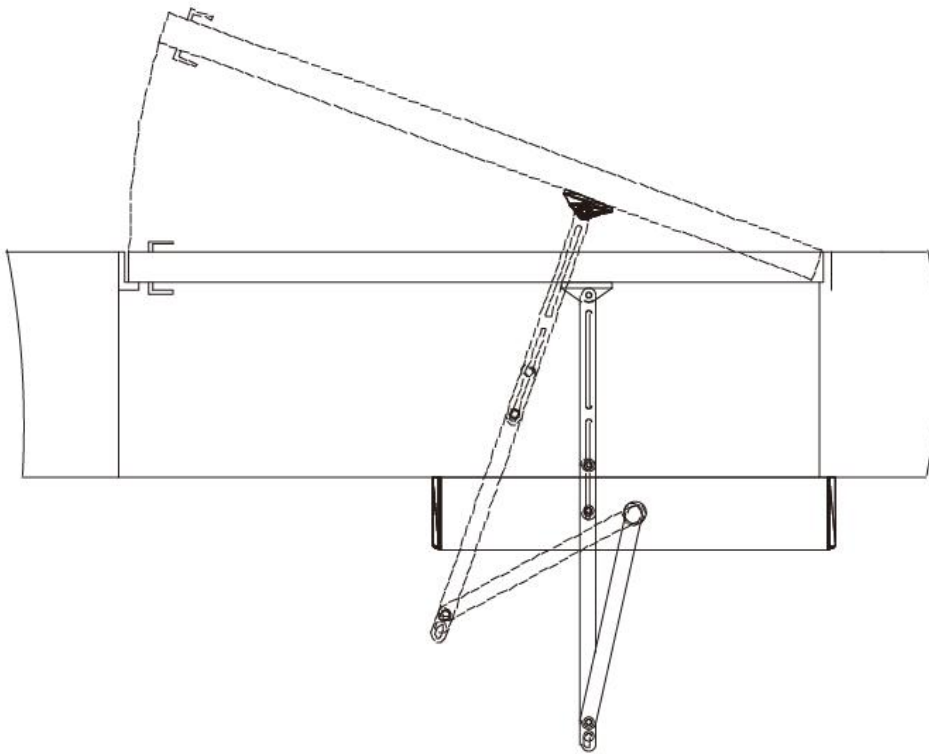
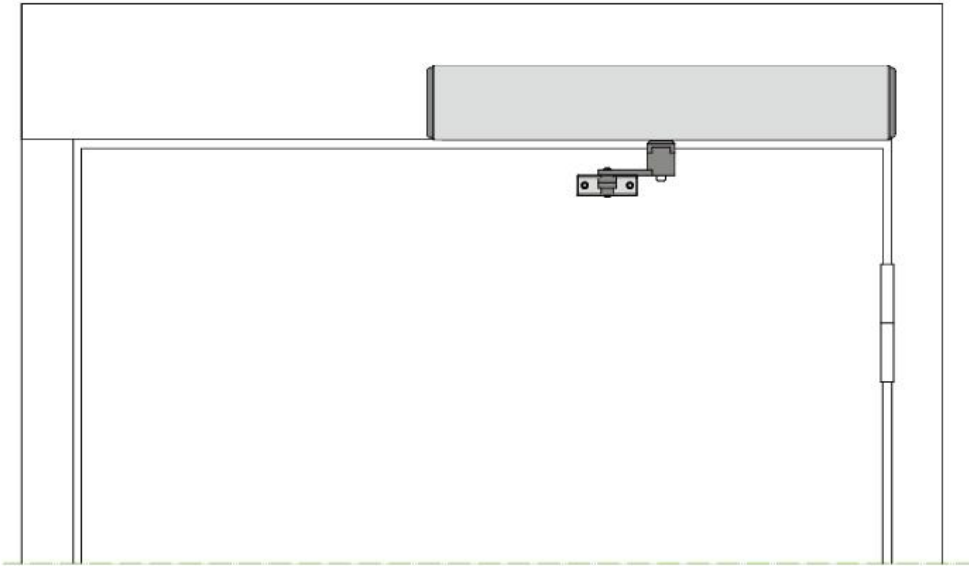

3.2 Installation of Base Plate

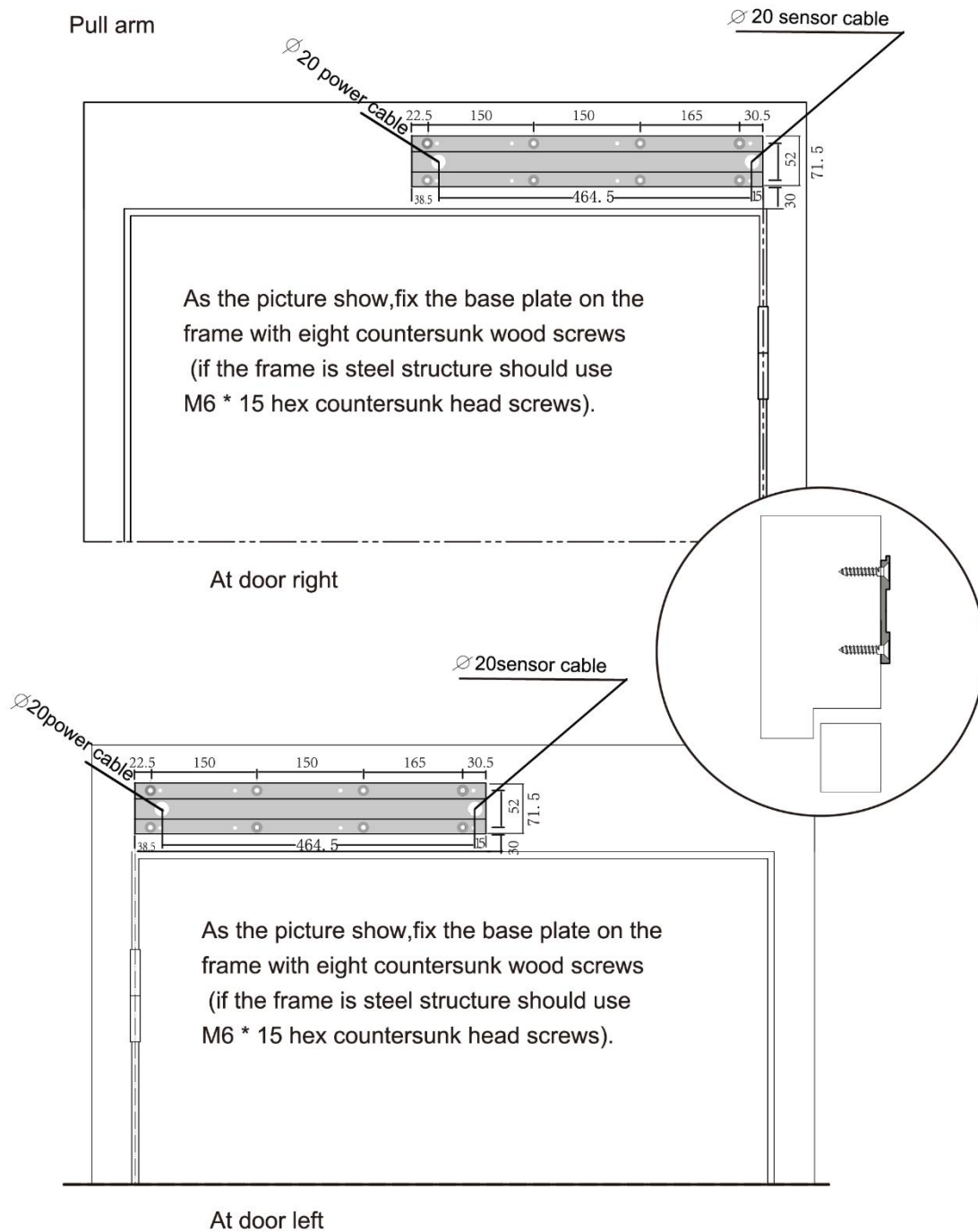

Push arm

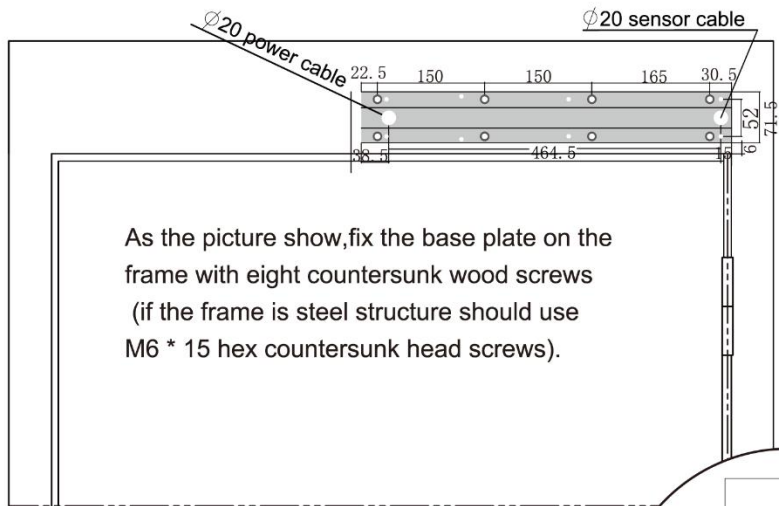

As the picture show,fix the base plate on the frame with eight countersunk wood screws (if the frame is steel structure should use M6 * 15 hex countersunk head screws).

At door right

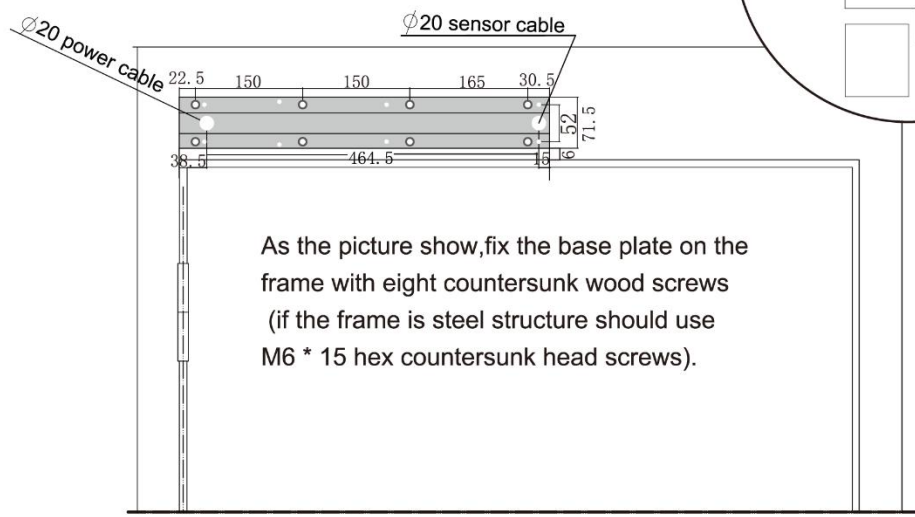
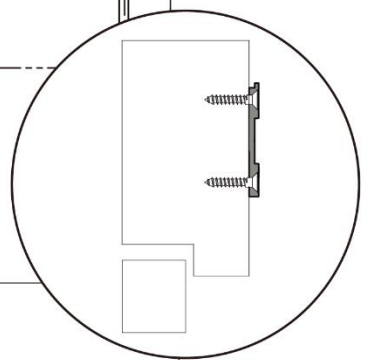

As the picture show,fix the base plate on the frame with eight countersunk wood screws (if the frame is steel structure should use M6 * 15 hex countersunk head screws).

At door left

3.3 Pull arm

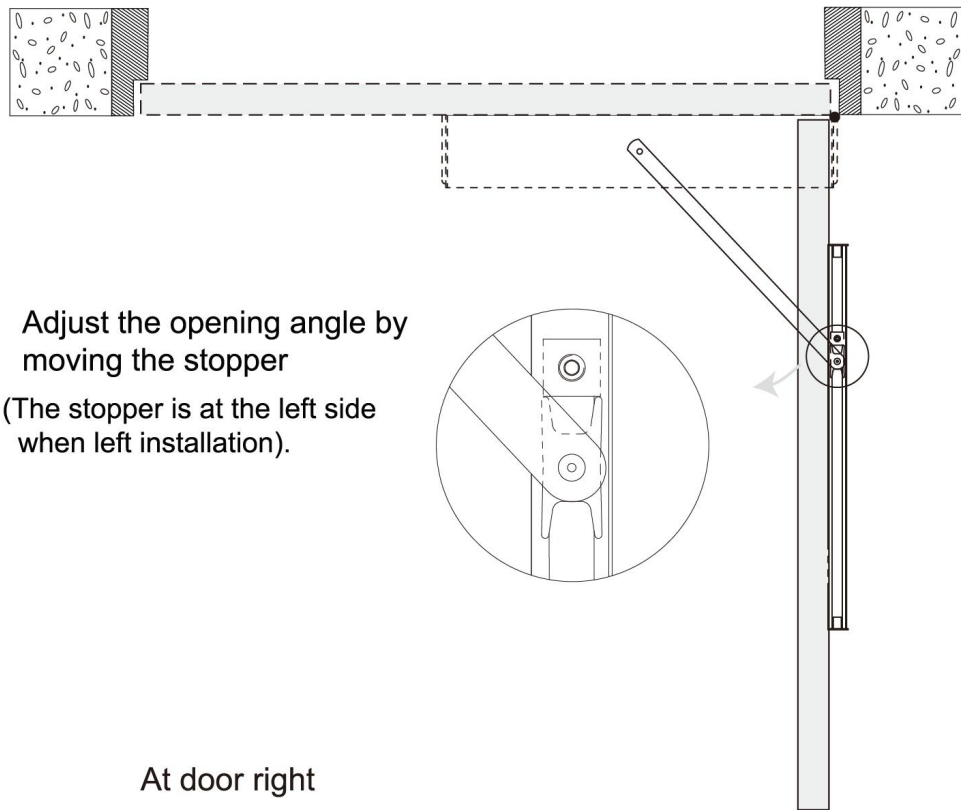
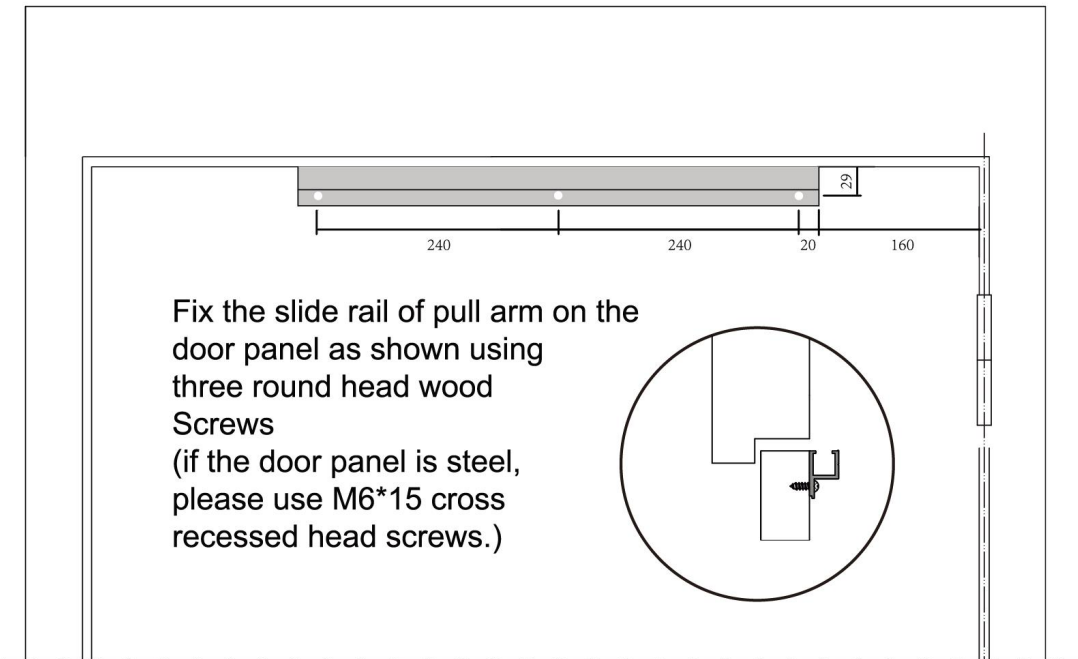

3.4 Push arm

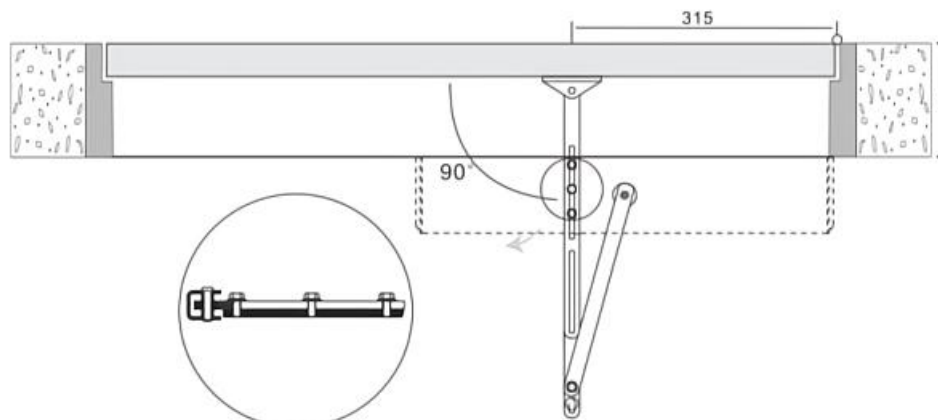
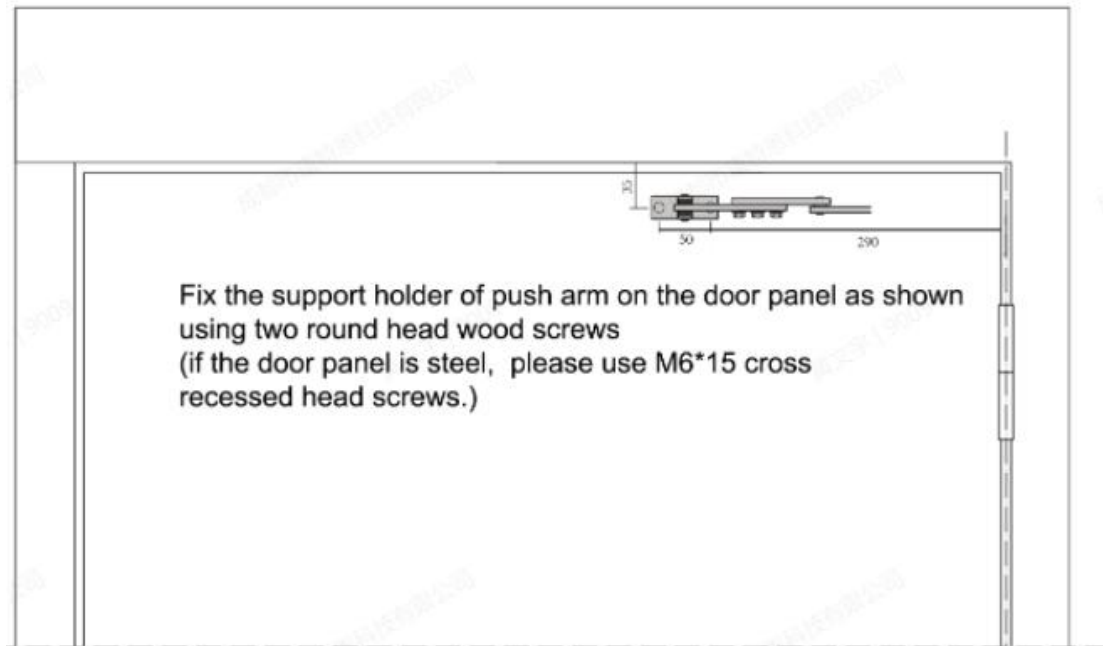

Loosen these three bolts and adjust the push arm length according to the door depth(L) until the angle between the push arm and door panel is 90°.

At the door right

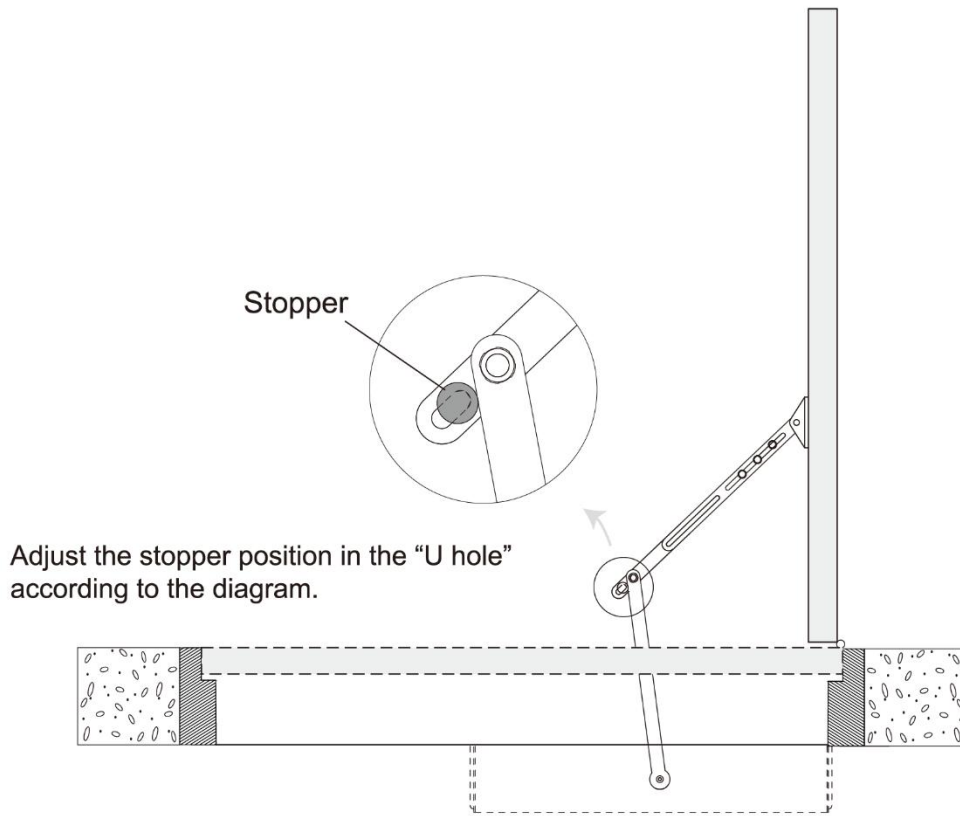

3.5 Operation System

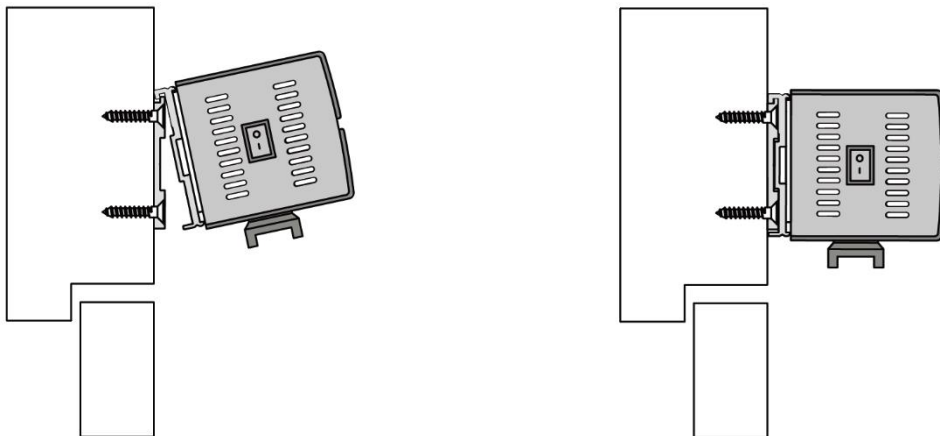

Hook the operation system on the finished base plate as shown, and fix it with eight hexagon socket head screws.

3.6 Cover

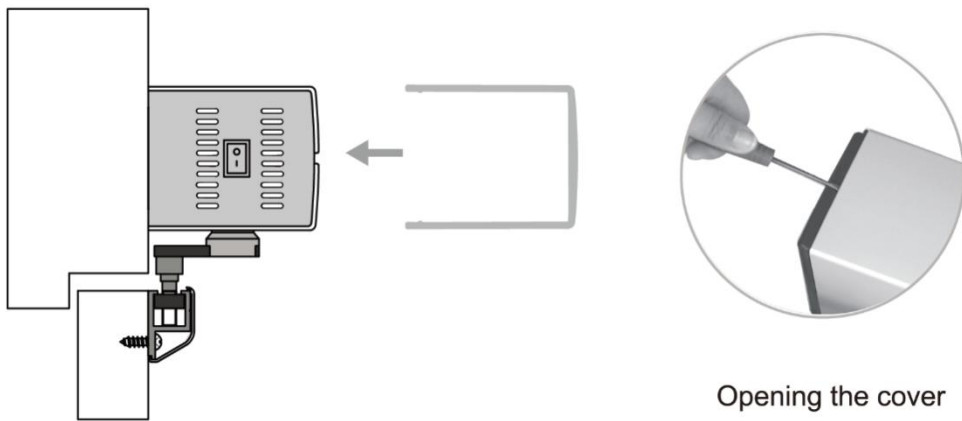

3.7 Connect the operation system and the pull arm

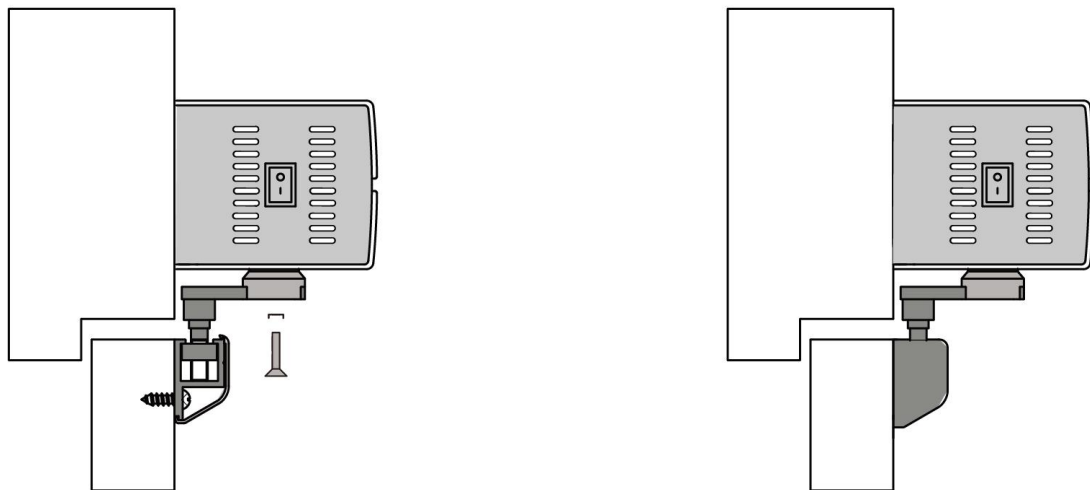

3.8 Connect the operation system and the push arm

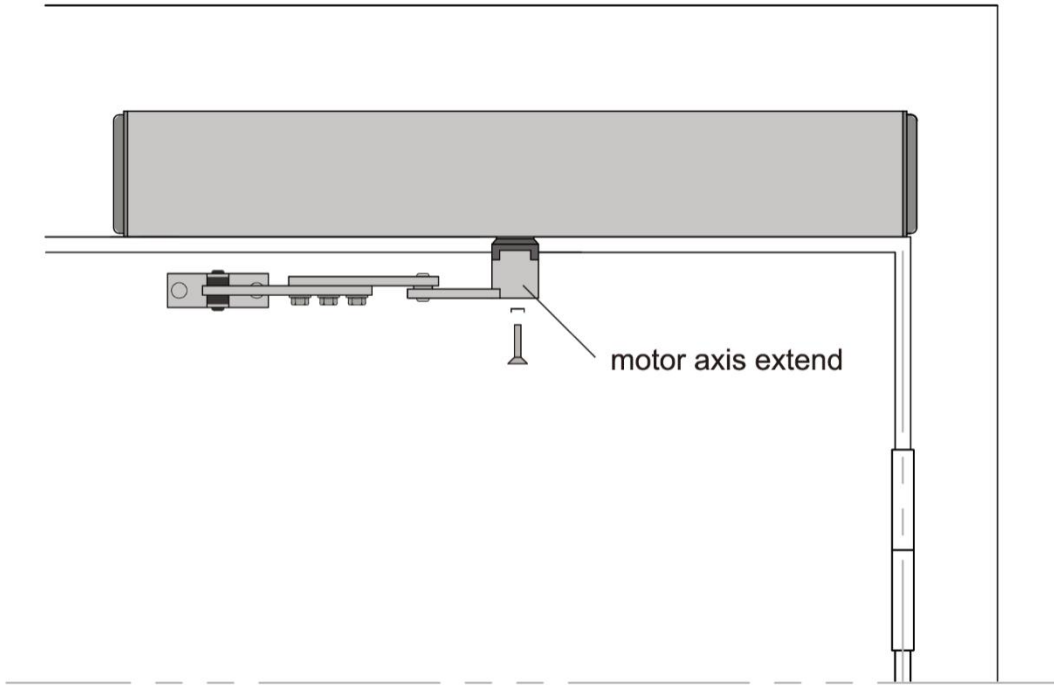

4. Electrical Connection

power cable

fuse 3A

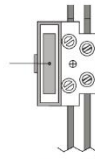

supply power 110~220V

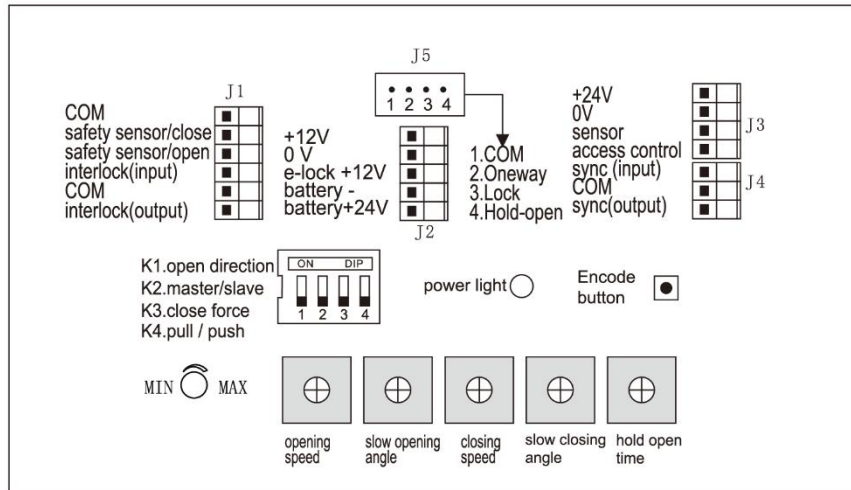

Safety sensor

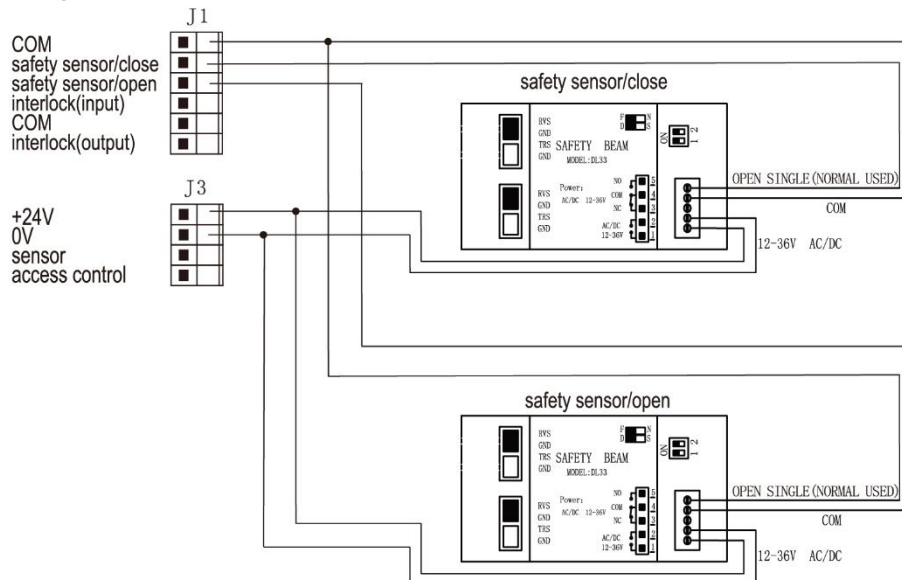

For safety, please connect the connection in J3 with 24V or J2 with 12V.

When the door is closing, the safety beam/close work, the door will open again. When the door opens the safety beam/open work the door will stop.

Note: The output power of 12V should less than 10W.

Sensor & Access Control

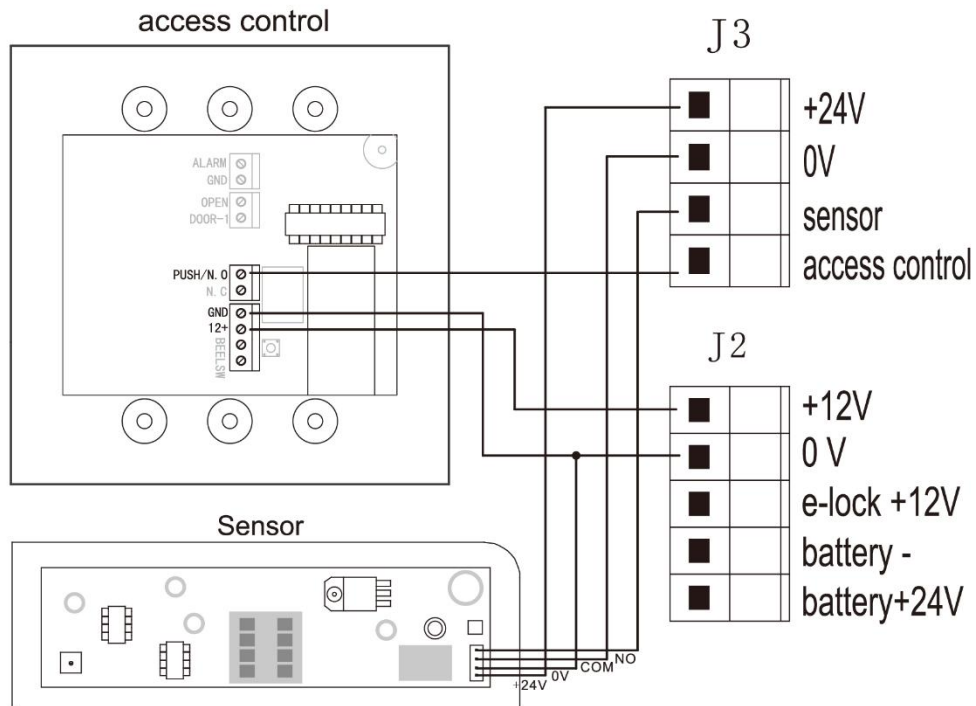

Note: The output power of 12V should be less than 10W.

Electric lock (Automatic lock)

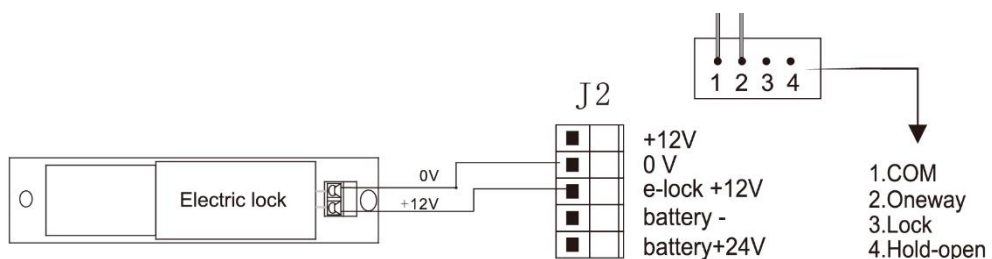

Note: The power supply voltage is 12V, the working current of the electric lock is less than 200mA, and the starting power is less than 800mA.

Electric lock (Remote control lock)

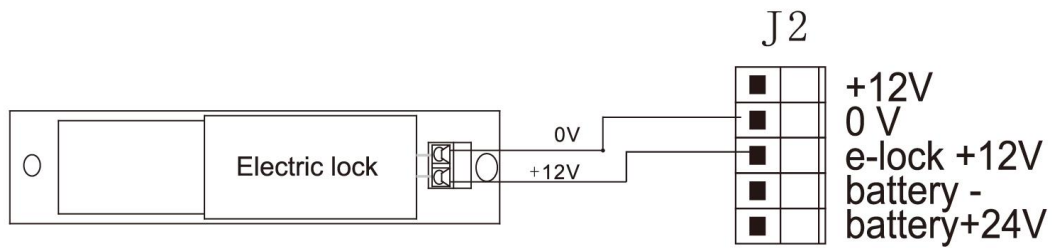

Note: The power supply voltage is 12V, the working current of the electric lock is less than 200mA, and the starting power is less than 800mA.

Backup battery

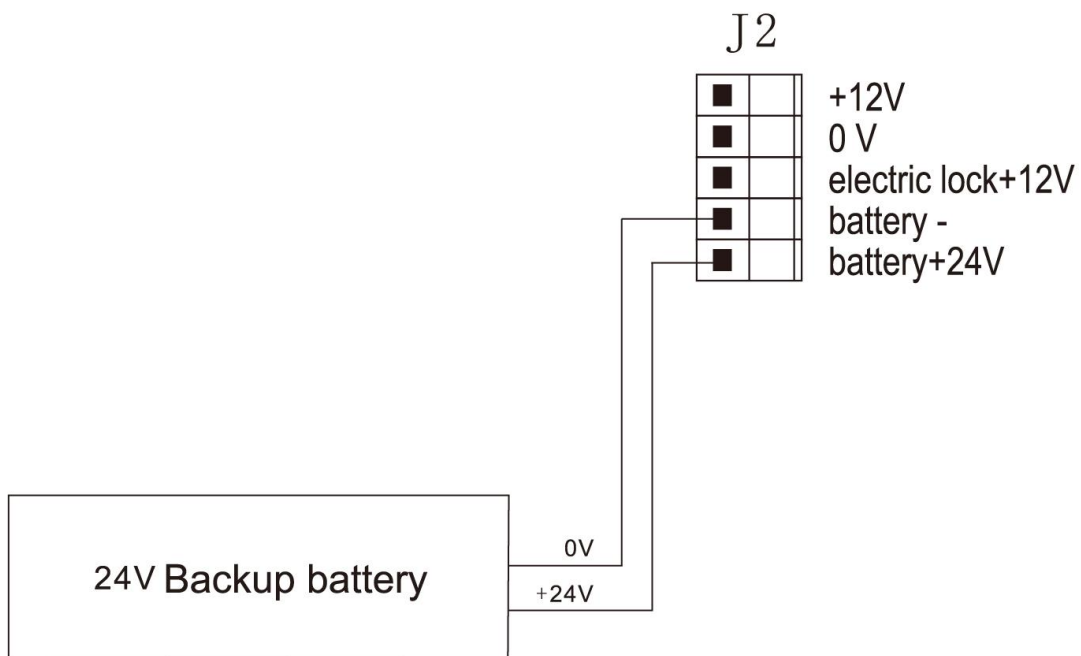

When the backup battery is directly connected to the controller for charging, the charging current must not be greater than 500mA.

Connection voltage "battery+" is 27V.

Double-door synchronous

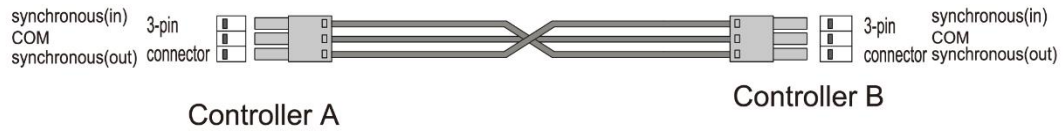

*When double opening, open first and close second is master door, close first and second open slave door; Master door turns K2 down, slave door turns K2 up.

*Sensors and access control system are connected to the master door controller.

Interlock

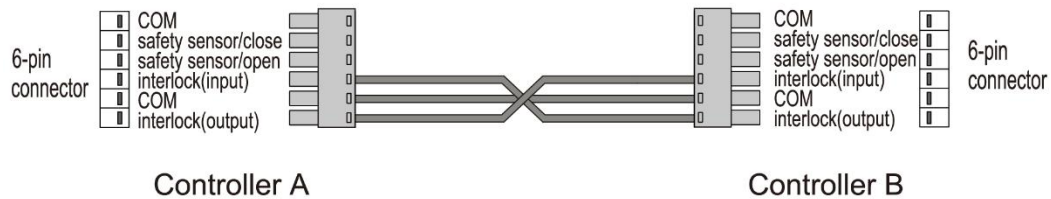

Note: Two doors share the same sensor or same signal source, both doors may hold open, in this case, exchange two signal wires of the sensor which is connected with the same controller, it doesn't matter whether controller A or B.

Optional: Functional key switch

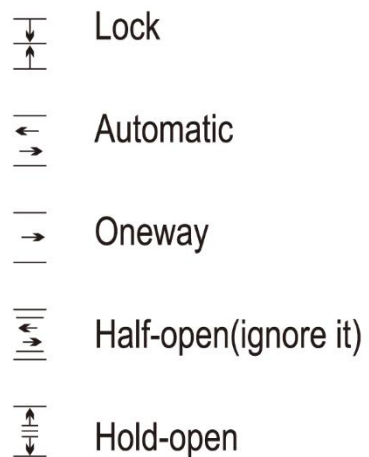
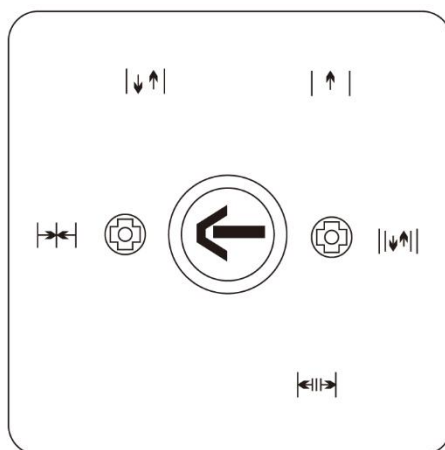
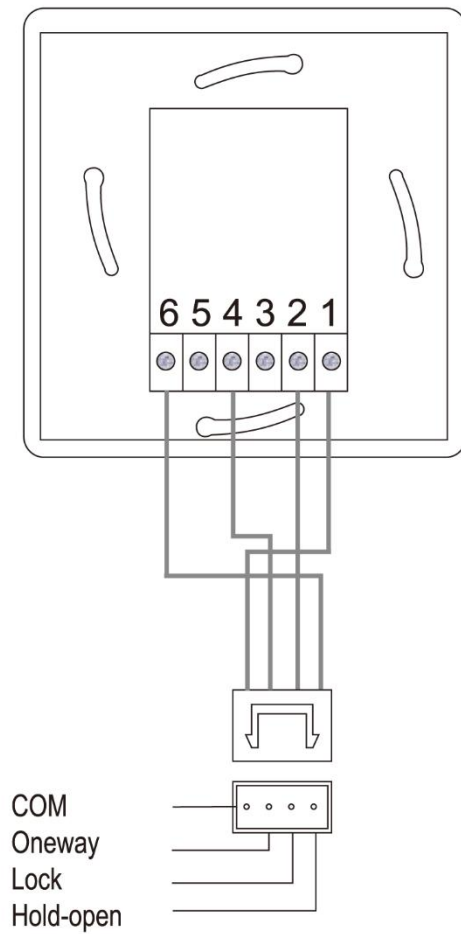

When the key switch is set in One Way status, the sensor signal is shielded, But the access control system works normally.

Optional: remote control

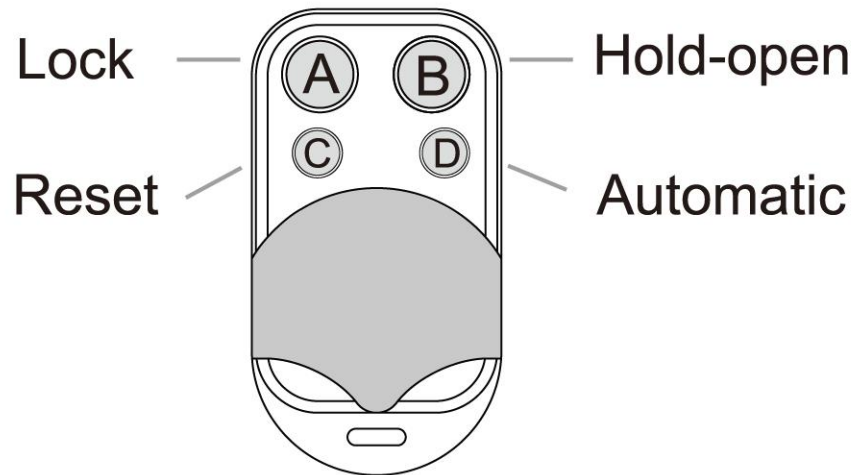

Encode remote control with the door controller:

1. Delete all: Long press the button "Encode" until the sound of the buzzer disappears, release the button.
2. Encoding: Long press the button "Encode", and the buzzer sounds. Then press any button on the remote control, and the buzzer stops sounding which means encoding successfully.

When using the remote control, the buzzer sounds for 2 seconds.

3. Note: when using the remote control, if the buzzer is "deep" twice, it means encoding failed, so please repeat above step 2.
4. Press the button "automatic" one time, and the door will open and dose one time.

One controller can be connected with a remote control not more than 10 pcs.

5. Parameters adjustment

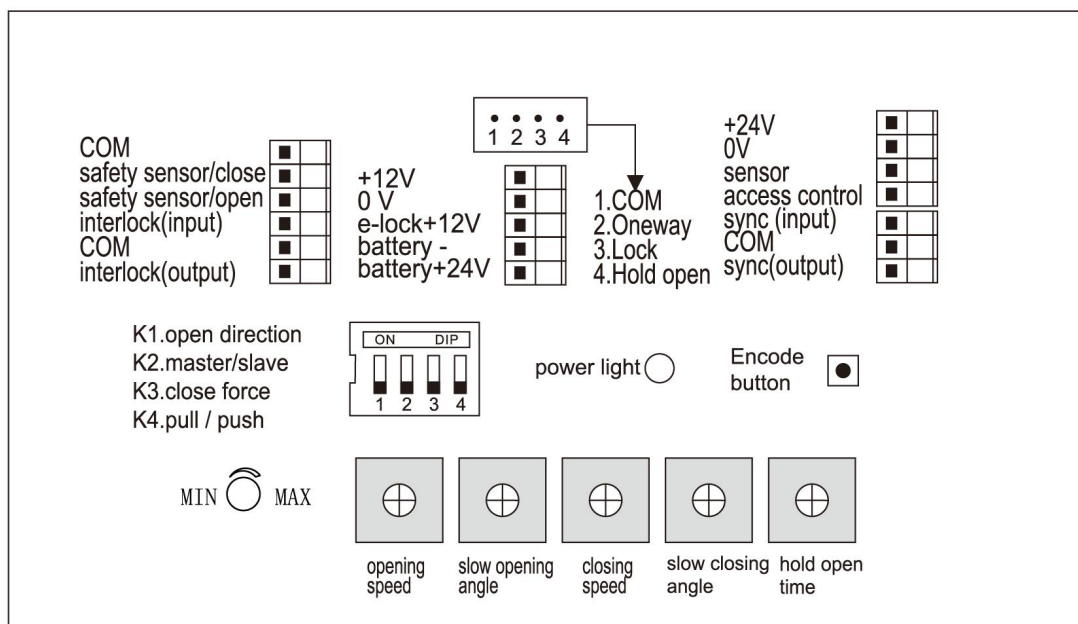

1. Set the DIP switch(K1-K4): after setting, power off and restart.

K1.Set opening direction: power on, the door goes to the closing direction, if not, change the switch position.

K2.Set master/slave door: when double-door synchronous, the master door turns K2 down (OFF), slave door turns K2 up(ON).

K3.Set closing force: no closing force, turn K3 down(OFF), want closing force, turn K3 up (ON).

K4.Select pull arm or push arm: pull arm, turn K4 down (OFF), push arm, turn K4 up (ON).

2. User adjustment:

1. Opening speed turn clockwise, speed increases
 2. Slow opening angle turn clockwise, angle widens
 3. Closing speed turn clockwise, speed increases
 4. Slow closing angle turn clockwise, angle widens
 5. Hold-open time turn clockwise, time extends
- Turn anticlockwise, it will decrease.