

NOTICE DE MONTAGE
ASSEMBLING INSTRUCTIONS
MONTAGEANLEIUNG
MANUAL DE MONTAJE
MONTAGEVOORSCHRIFT
INSTRUÇÕES DE MONTAGEM
ISTRUZIONI DI MONTAGGIO
ИНСТРУКЦИЯ ПО СБОРКЕ
Naputci za montažu

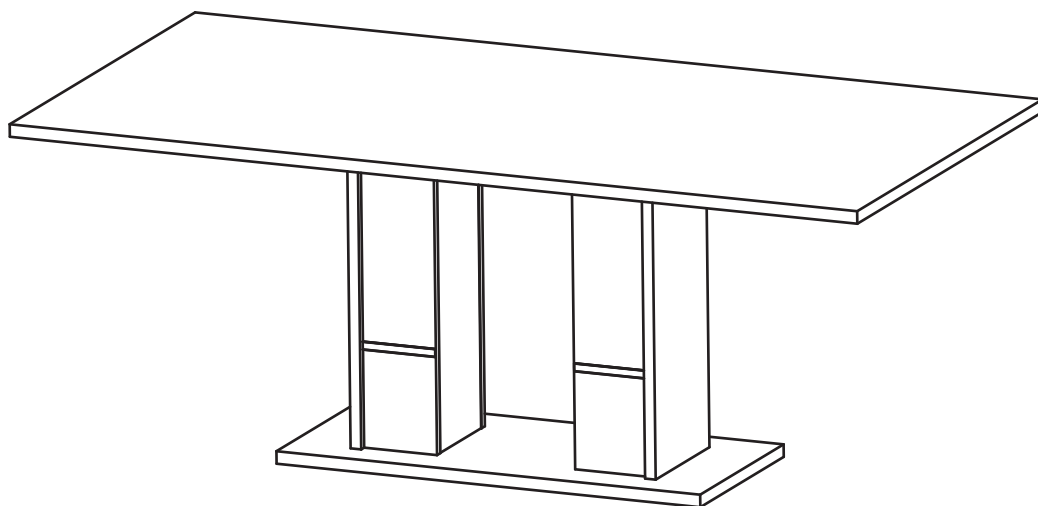

2H00

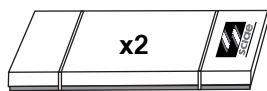

Package 1: 32 Kg
Package 2: 40 Kg

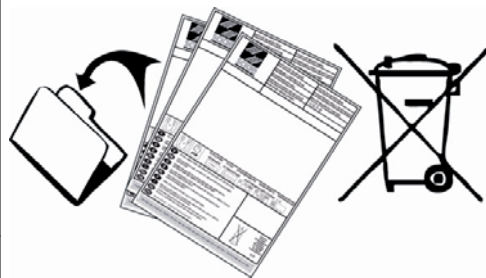

F POUR L'APRES-VENTE, RETOURNEZ AU MAGASIN AVEC CETTE NOTICE

GB FOR THE AFTER SALES, GO BACK TO THE SHOP WITH THIS ASSEMBLY INSTRUCTION

D WENDEN SIE SICH BITTE AN IHREN HANDLER UND GEBEN SIE IHM DIE KENNUMMER DES MOBELS UND DIE TEILNUMMER

E EN CASO DE SERVICIO POST-VENTA DEBEN DE VOLVER A LA TIENDA CON LAS INSTRUCCIONES DE MONTAJE

NL VOOR SERVICE NA VERKOOP, GA NAAR UW LEVERANCIER MET DEZE MONTAGE HANDLEIDING

P PARA O POS VENDA, VOLTE A LOJA COM ESTA FOLHA

I SERVIZIO POST VENDITA: E NECESSARIO PRESENTARSI SUL PUNTO VENDITA CON QUESTE ISTRUZIONI DI MONTAGGIO

RU ДЛЯ ПОСЛЕПРОДАЖНОГО ОБСЛУЖИВАНИЯ ПРОСЬБА ОБРАТИТЬСЯ В МАГАЗИН ПРЕДЪЯВИВ НАСТОЯЩУЮ ИНСТРУКЦИЮ ПО СБОРКЕ

HR U SLUČAJU REKLAMACIJE, VRATITE SE NA PRODAJNO MJESTO S OVIM UPUTAMA ZA MONTAŽU

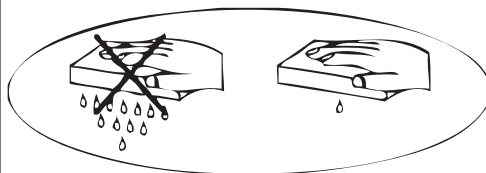

	+40°C +104°F	
	HYGROMETRIE HYGROMETRY 40%-65%	
	+15°C +59°F	

1 an
1 year

OK

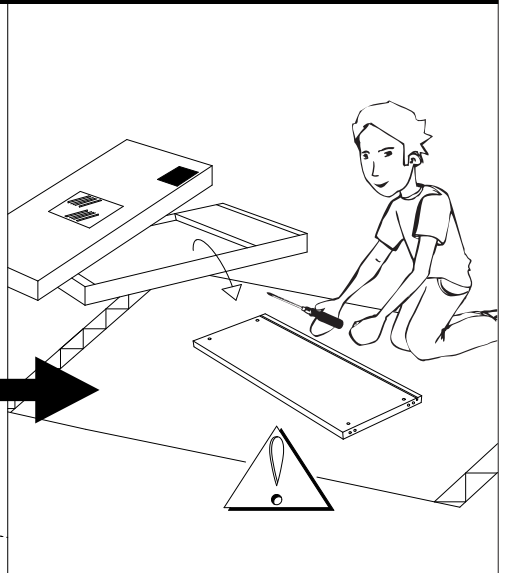
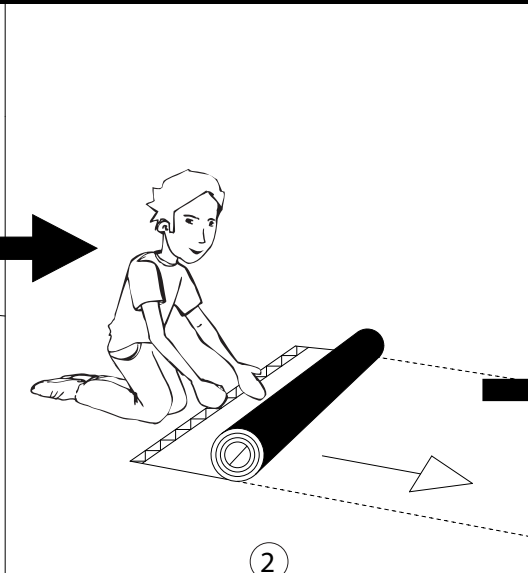
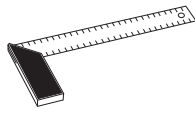
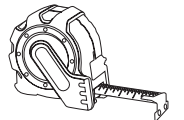
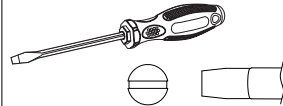
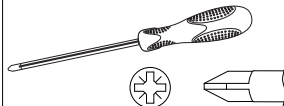
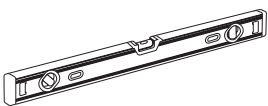
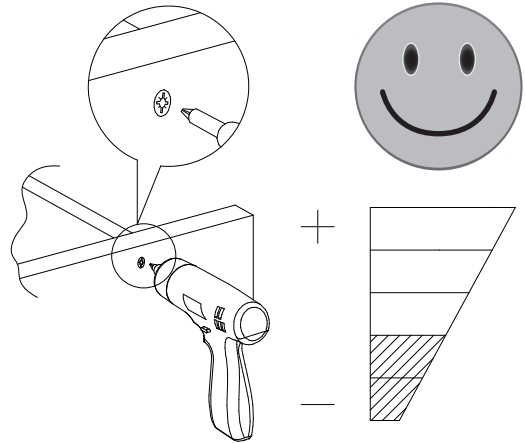
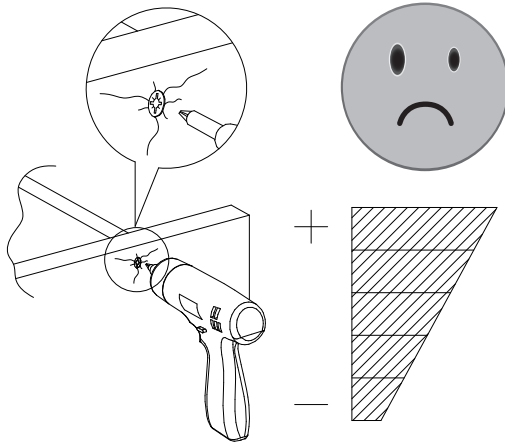
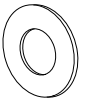
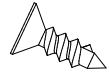
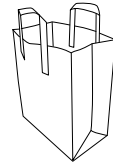
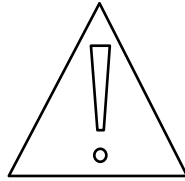

DESIGNATION	LONGUEUR	LARGEUR	EPAISSEUR	N° PIECE	QTE	COLIS
Semelle	1000	450	28	01	1	01
Côté de fût	699	290	25	02	2	01
Platine	1000	300	25	04	1	01
Côté de fut intérieure	699	222	18	05	2	01
Face de fût	699	172	18	07	4	01
Plateau	2000	1000	28	08	1	02

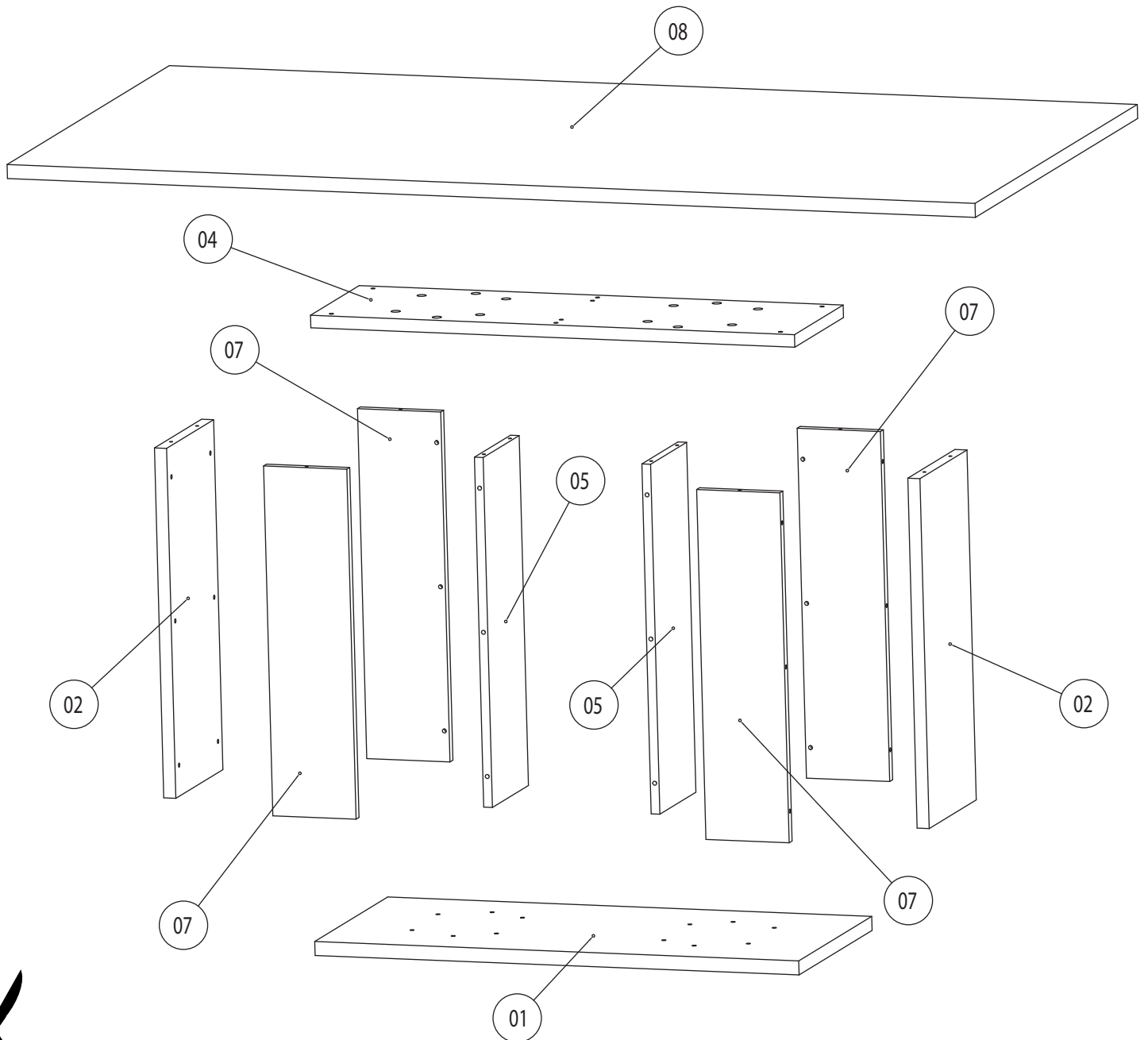

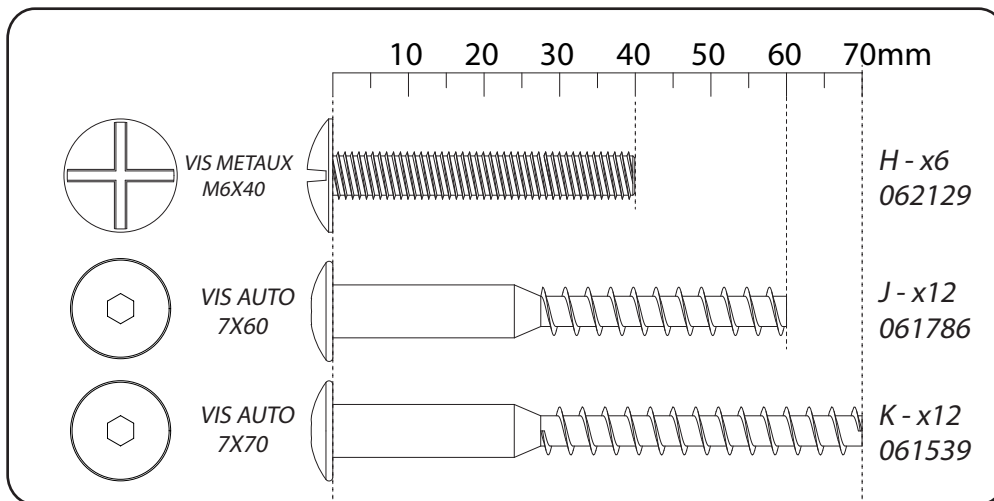
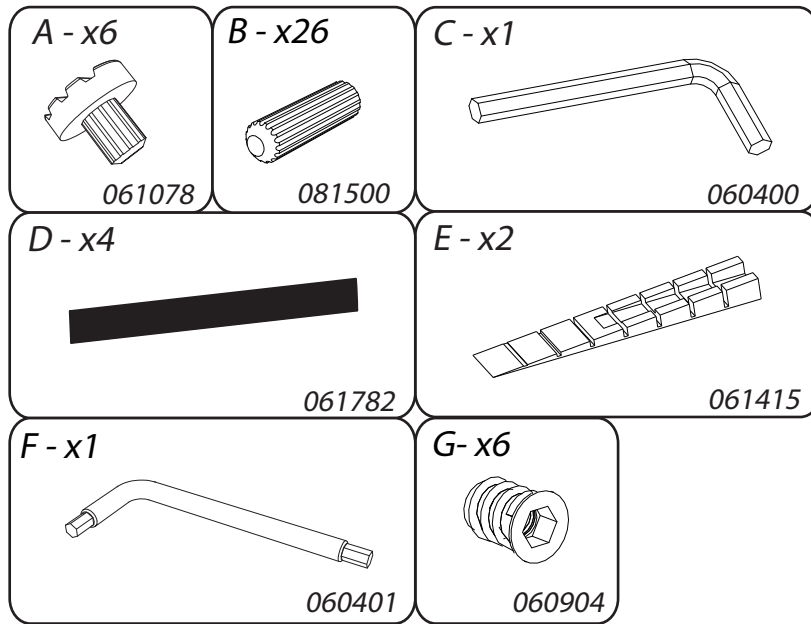

2

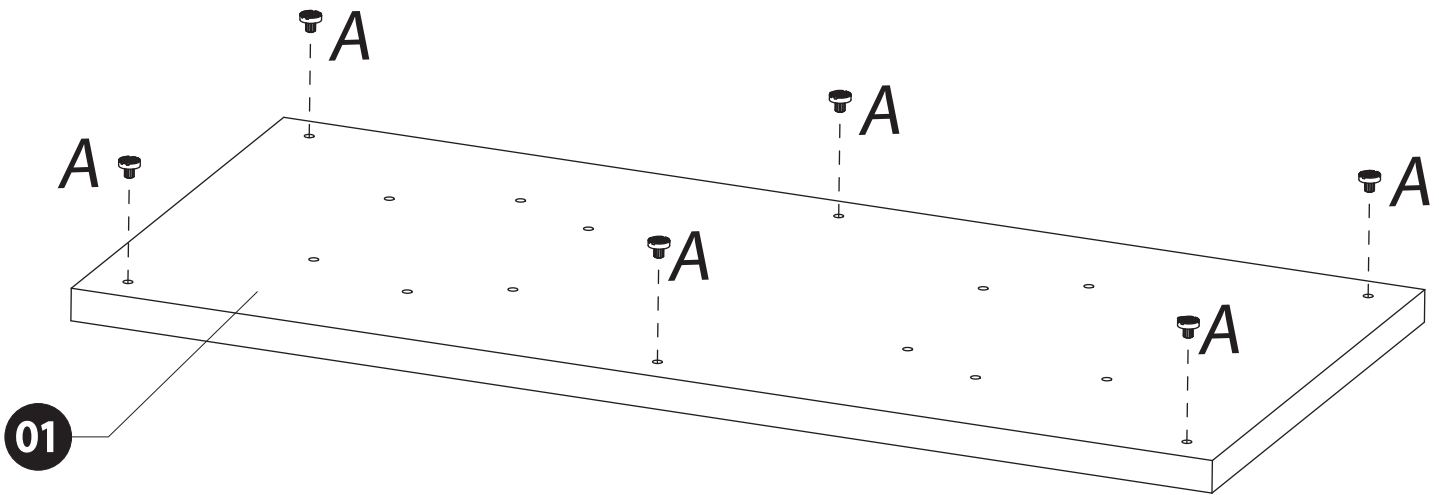
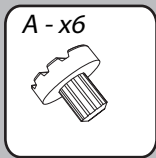

3

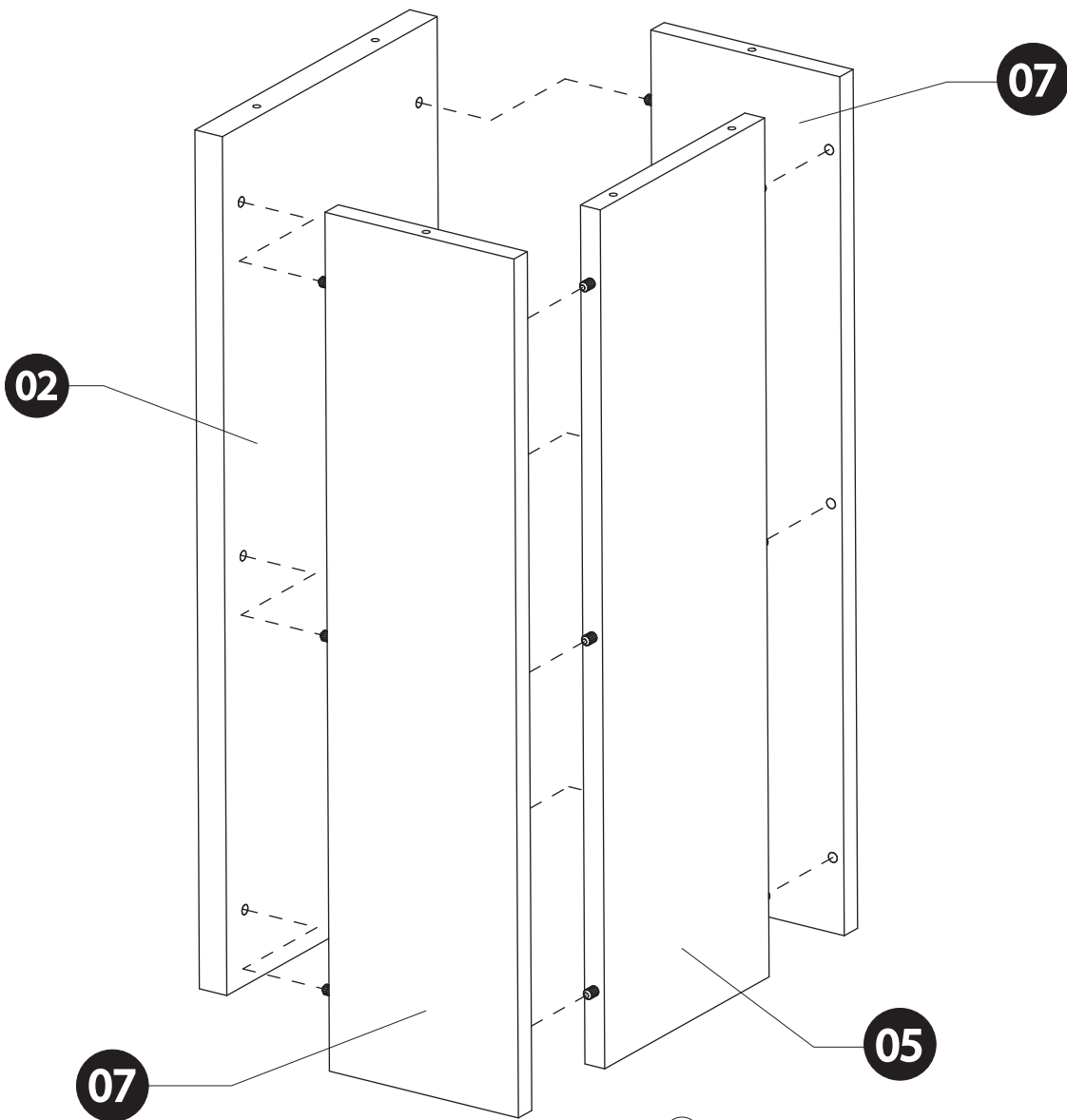

x2

6

5

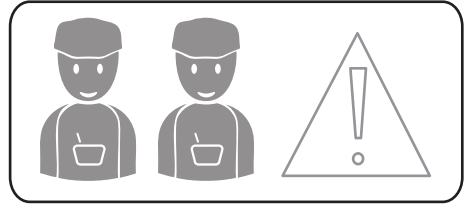
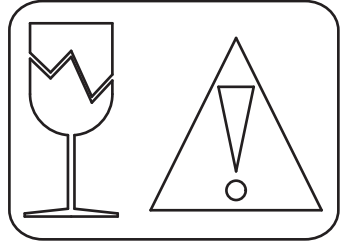
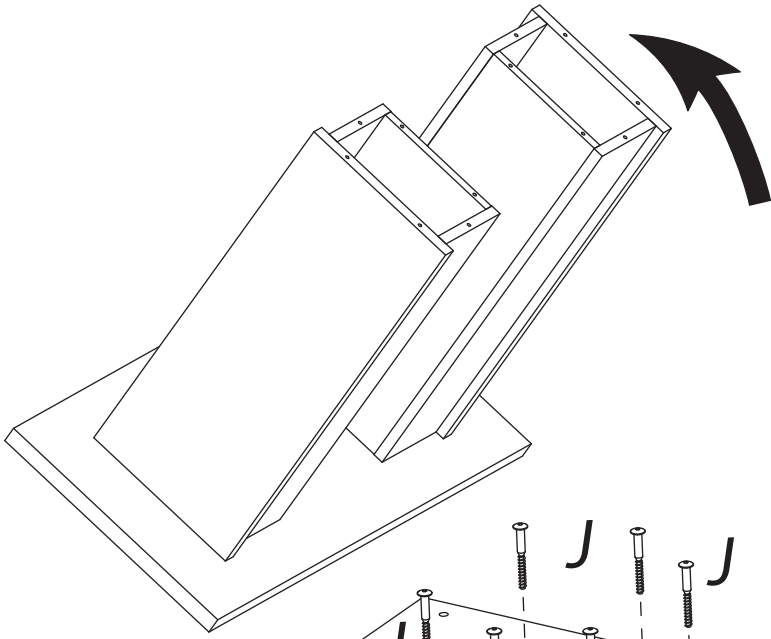
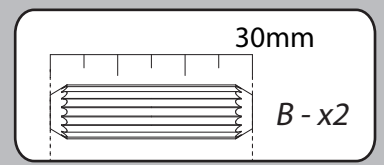
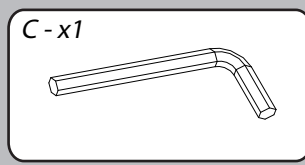
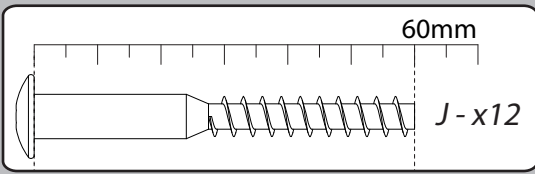

04

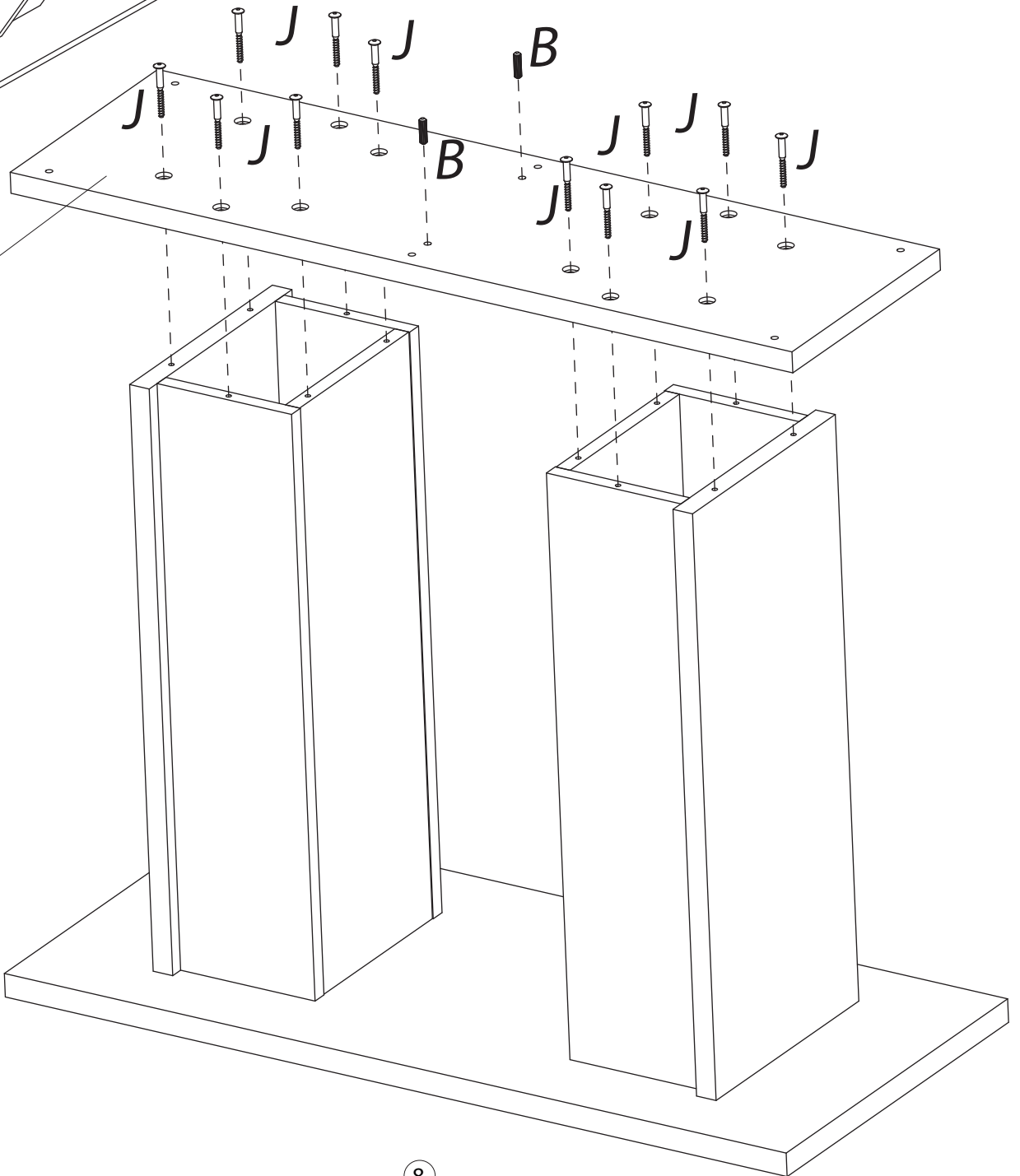

6

D-x4

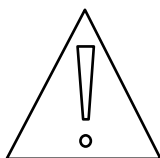
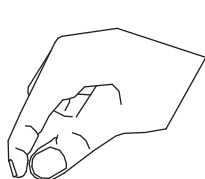
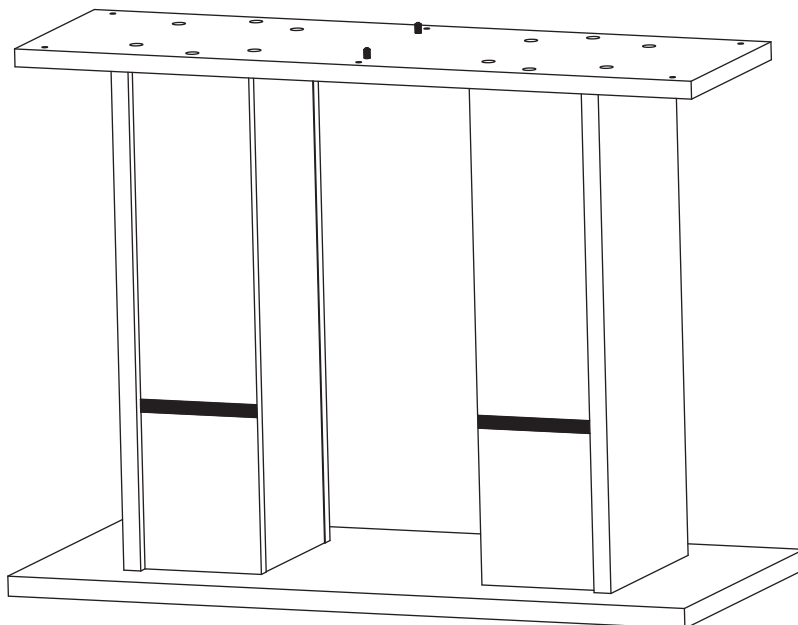

x4

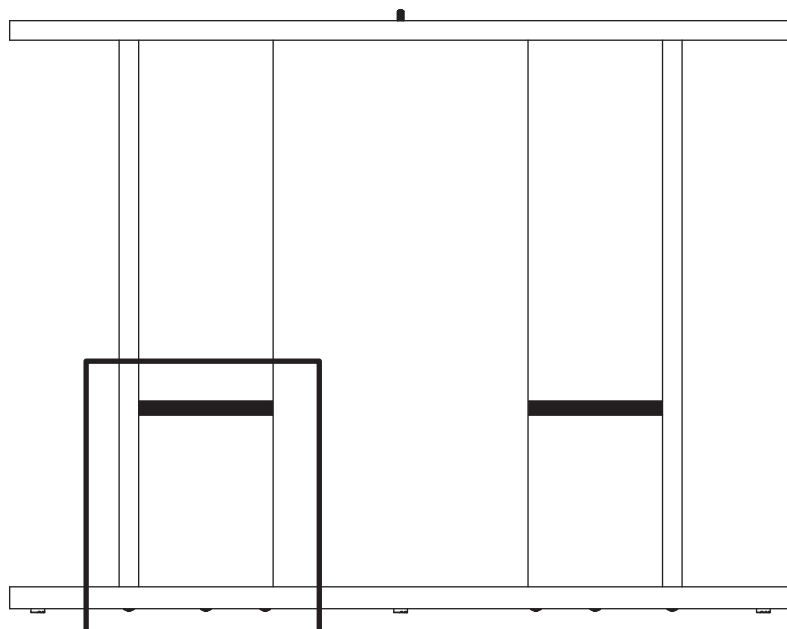
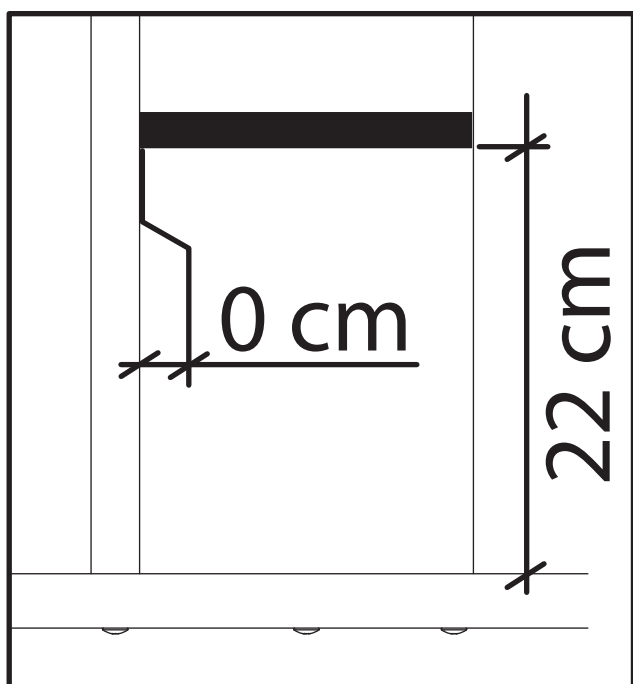

7

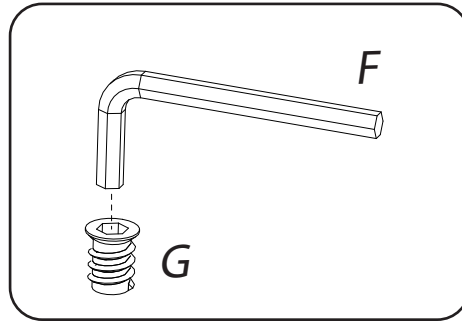
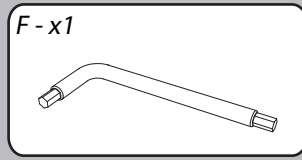
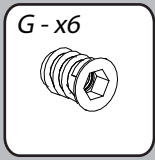

08

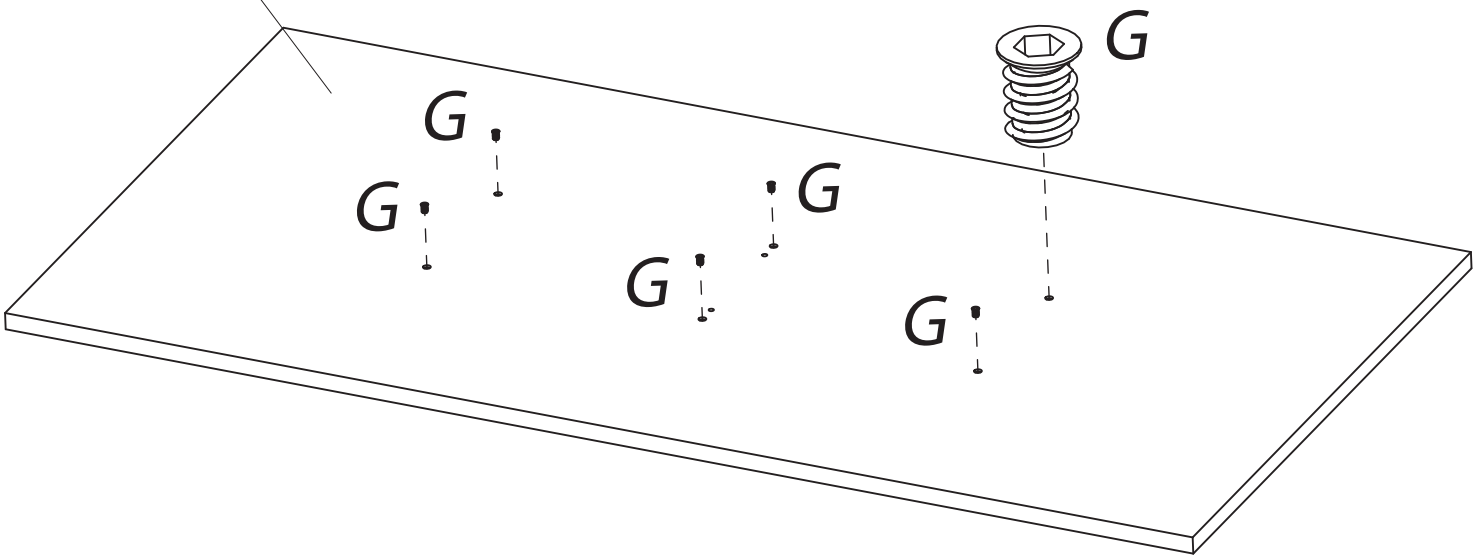

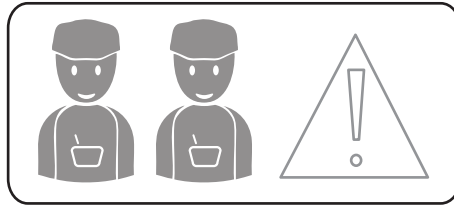
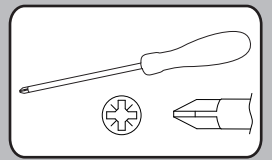
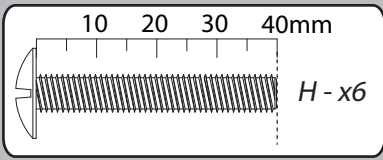

08

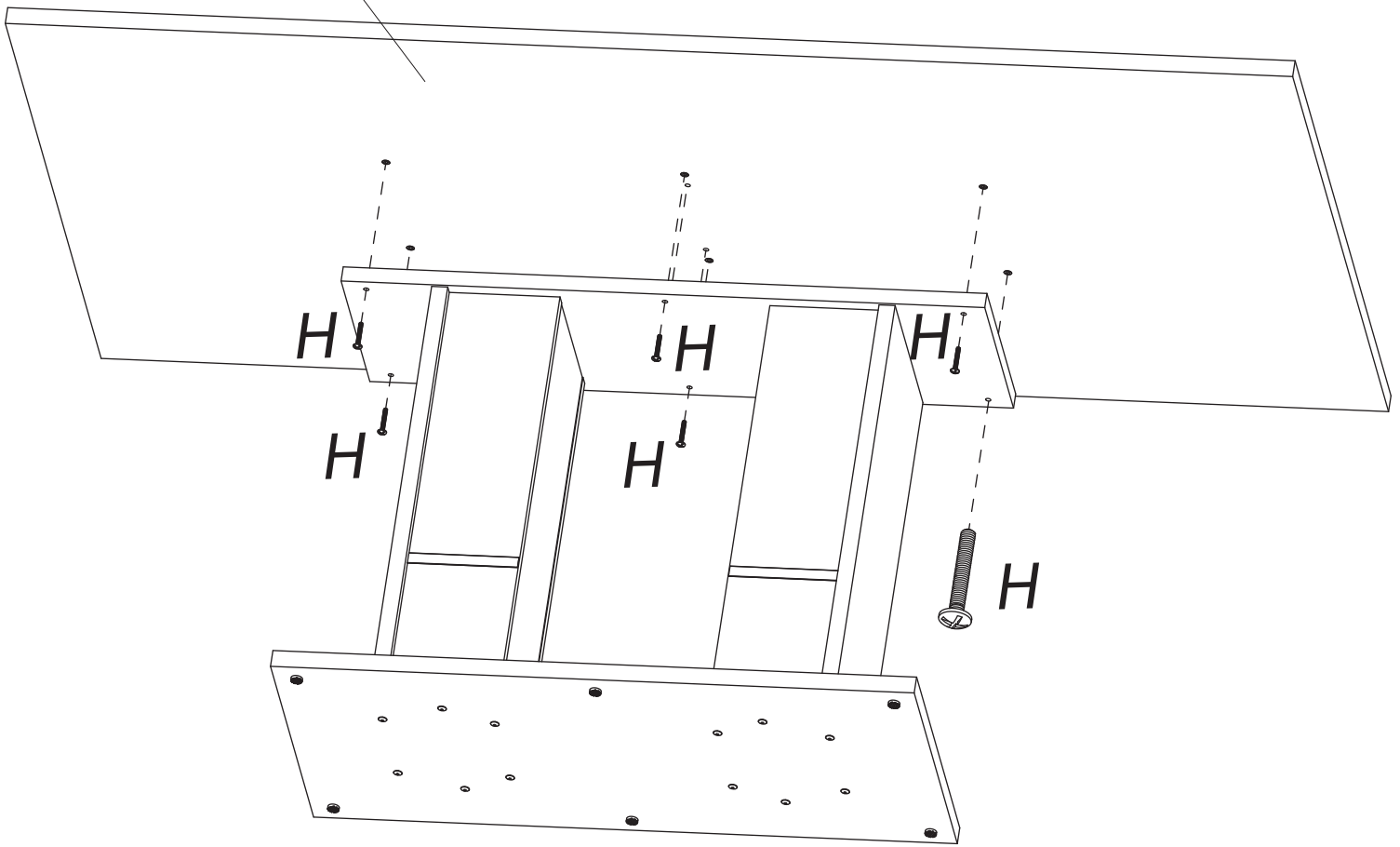

9

E - x2

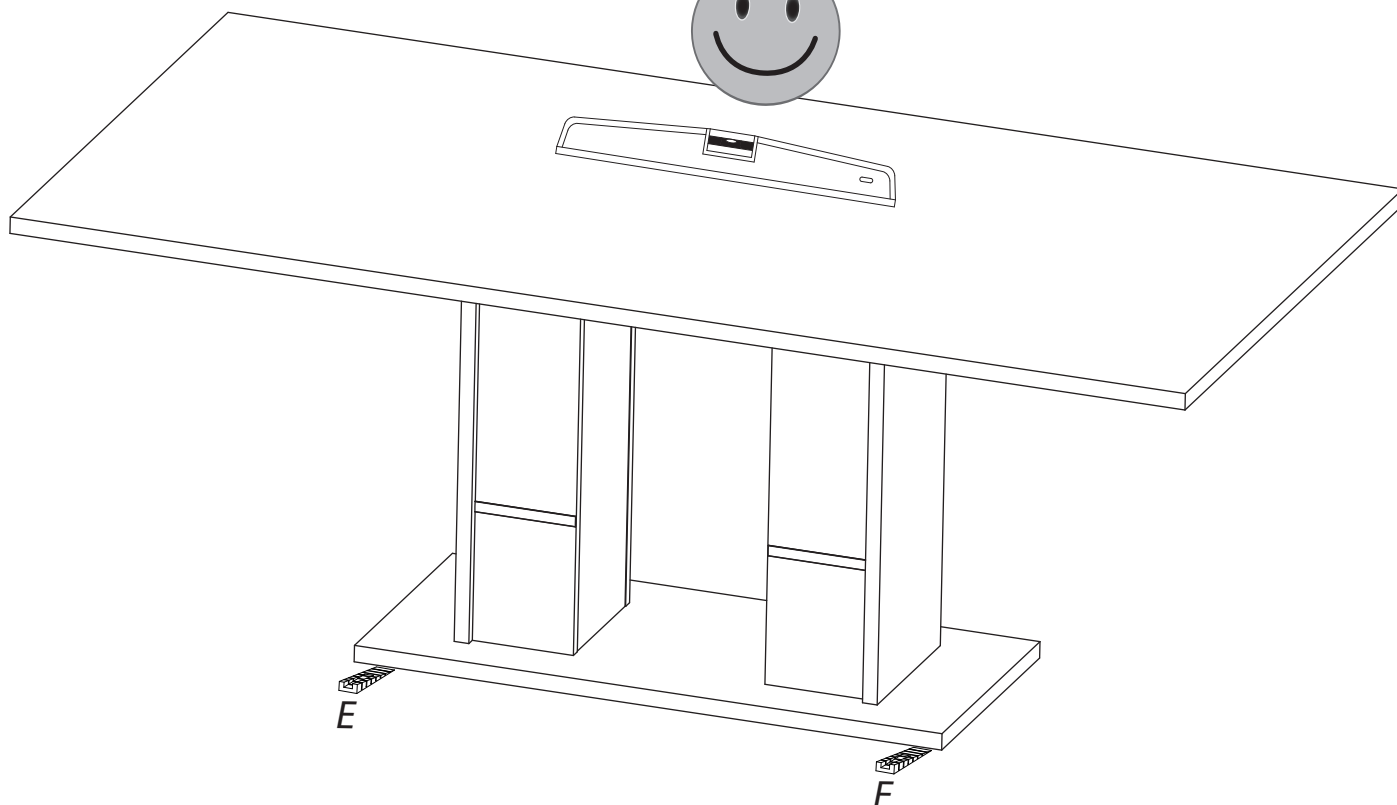
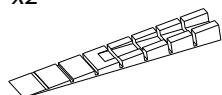

Table rectangulaire fût composé de panneaux de particules revêtus papier décor Karlstad Oak (Chêne Suédois) et laque beige argile brillante. La semelle et le plateau sont laquées noir brillante.

L.180 cm - H.89 cm - P.40 cm.

A monter soi-même.

-FRANCAIS : Recommandations de démontage :

En cas de déménagement, il convient de procéder au démontage de votre meuble, en ôtant toute la visserie.

-ENGLISH : Disassembly advices:

In case of moving, it is needed to dismantle the furniture removing the fittings.

-DEUTSCH : Empfehlungen für die Demontage:

Bei Transport bitte alle Beschläge demontieren.



FR

**Donnez ou recyclez
vos meubles.**



Association

OU



Magasin

OU



Déchèterie

<https://quefairedemesdechets.fr>

"Les meubles contenant des panneaux à base de bois (panneaux de particules, panneaux de fibres, contreplaqué...) peuvent émettre des substances polluantes dans l'air intérieur. Il est ainsi recommandé, après l'installation du meuble dans son logement, d'aérer fréquemment la pièce concernée pendant au moins quatre semaines afin de réduire son exposition aux polluants émis par le meuble."