

# ASSEMBLY INSTRUCTIONS

---

## TOOLS REQUIRED



Allen Wrench

(Included)

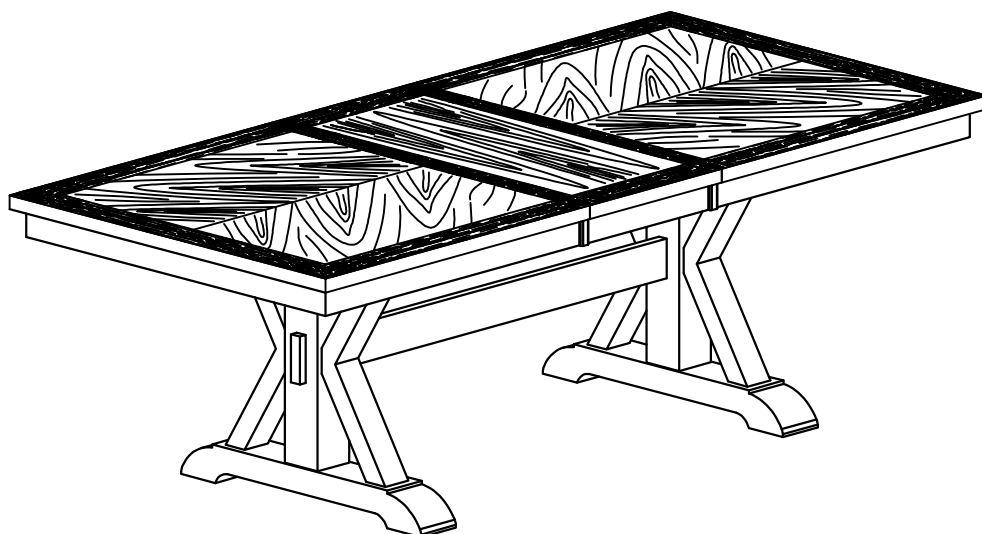

2 - People  
Recommended

## ASSEMBLY RATING



EASY —————> DIFFICULT

The Assembly Rating is a 5-point system showing the level of effort needed to assemble a specific product.

# PRE ASSEMBLY INTRODUCTION

We understand building ready-to-assemble furniture can be a challenging experience for some. To help avoid confusion, we have provided some helpful tips that may speed up the process.



## Teamwork

ALWAYS have at least two people to help with transporting and assembling the product to avoid potential injury and/or damage.



## Suitable Location

Assembling near the area of the intended location is highly recommended.



## Sufficient Space

Make sure you have enough space to move around during the assembly.

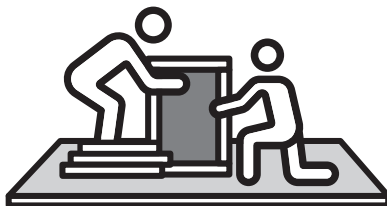

## Avoid Scratches

Use cardboard, blankets or a carpeted area while assembling furniture to prevent scratches.

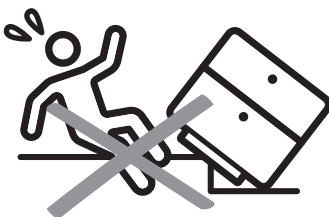

## Flat Surface

Make sure the furniture rests on a flat and level surface with each leg evenly touching the floor.

# ASSEMBLY AND CARE ADVICE



**FAILURE TO FOLLOW THE GUIDELINES BELOW MAY RESULT IN INJURY AND/OR PROPERTY DAMAGE.**



Position each part correctly and insert screws or bolts into their respective holes.

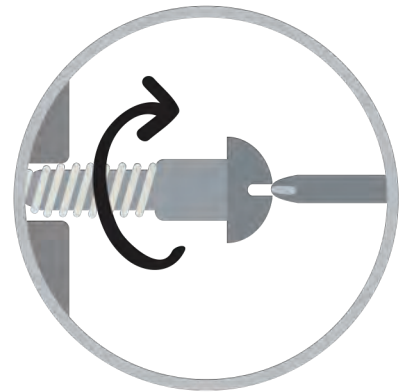

Turn clockwise to tighten and only tighten when step is completed or when instructed to do so.



Use the appropriate hand tools or power tools for assembly. Select steps, such as tightening screws and/or bolts, may require hand tools to avoid causing damage during assembly.



Save the instructions and store any supplied tools for later maintenance.

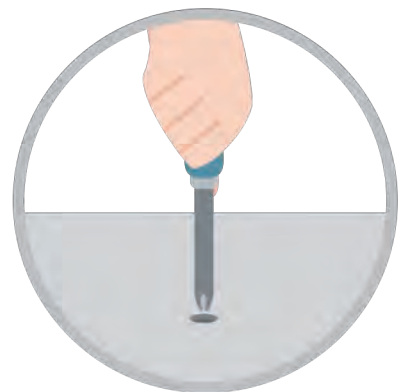

After two weeks, check and tighten any loose hardware and repeat again every six months thereafter.

**IT IS THE USER'S RESPONSIBILITY TO MAINTAIN THE FURNITURE. THE HARDWARE MAY LOOSEN OVER TIME AND MAY CAUSE THE FURNITURE TO BE WOBBLY AND UNABLE TO SUPPORT ITS INTENDED WEIGHT CAPACITY. THIS MAY LEAD TO COLLAPSE AND MAY CAUSE SERIOUS INJURY.**

# DINING TABLE



- Please keep instructions for future reference.
- Check the quantity and irregularity of parts and hardware before you start.

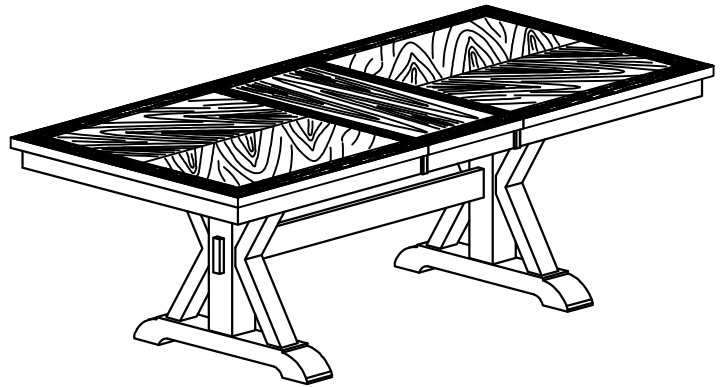

## PARTS

#1 1pc

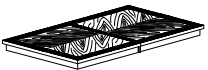

Top Table

#2 1pc

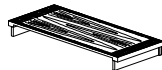
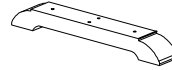

Table Leaf

#3 2pcs



Base

#4 2pcs

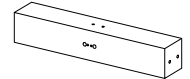

Pedestal Column

#5 4pcs

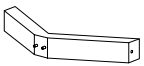

Leg

#6 2pcs



Mounting Plate 1

#7 2pcs

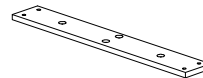

Mounting Plate 2

#8 1pc



Stretcher

## HARDWARE

#A 12pcs



Bolt Ø5/16" x 3"

#B 8pcs



Bolt Ø5/16" x 2"

#C 16pcs



Bolt Ø5/16" x 1-1/2"

#D 36pcs



Lock Washer  
Ø5/16"x13mm

#E 36pcs



Flat Washer  
Ø5/16"x19mm

#F 1pc



Allen Wrench M4

#G 2pcs







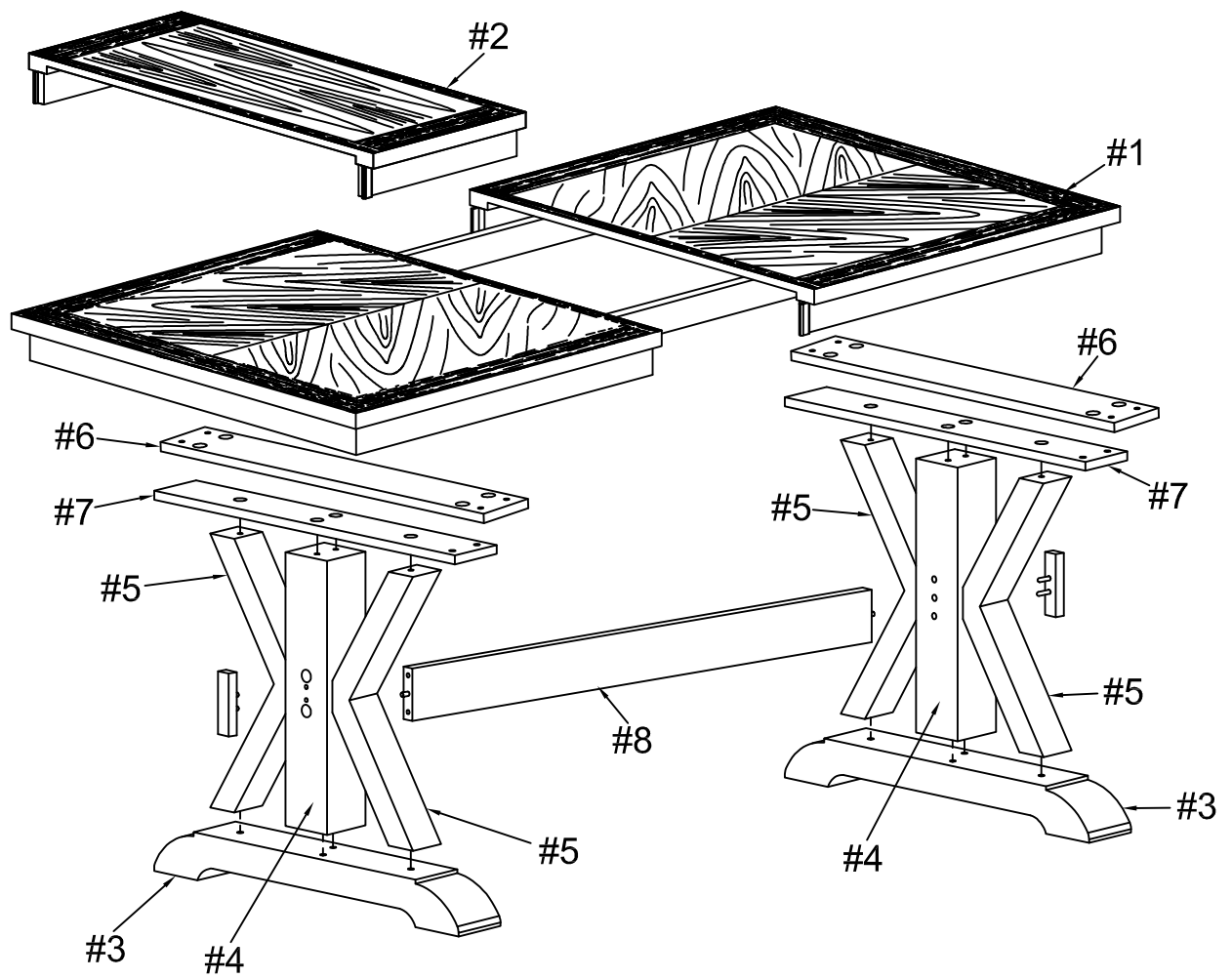



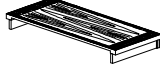

Wooden Plug

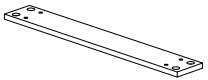
# Exploded View

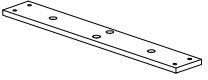

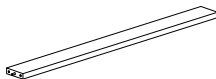
# packed in 2 cases

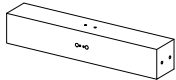
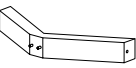
Carton	Disignation	Part	Hardware
	Top Table	#1 	 #A x 12pcs
	Table Leaf	#2 	 #B x 8pcs  #C x 16pcs
	Mounting Plate 1 (2pcs)	#6  x 2	 #D x 36pcs
	Mounting Plate 2 (2pcs)	#7  x 2	 #E x 36pcs  #F x 1pc
	Stretcher	#8 	 #G x 2pcs
	Base (2pcs)	#3  x 2	
	Pedestal Column (2pcs)	#4  x 2	
	Leg (4pcs)	#5  x 4	

# ASSEMBLY INSTRUCTIONS

## 1

- Part #3 x2pcs
- Part #4 x2pcs
- Part #5 x4pcs
- Part #7 x1pc
- Hardware #B x8pcs
- Hardware #D x8pcs
- Hardware #E x8pcs
- Hardware #A x8pcs
- Hardware #D x8pcs
- Hardware #E x8pcs

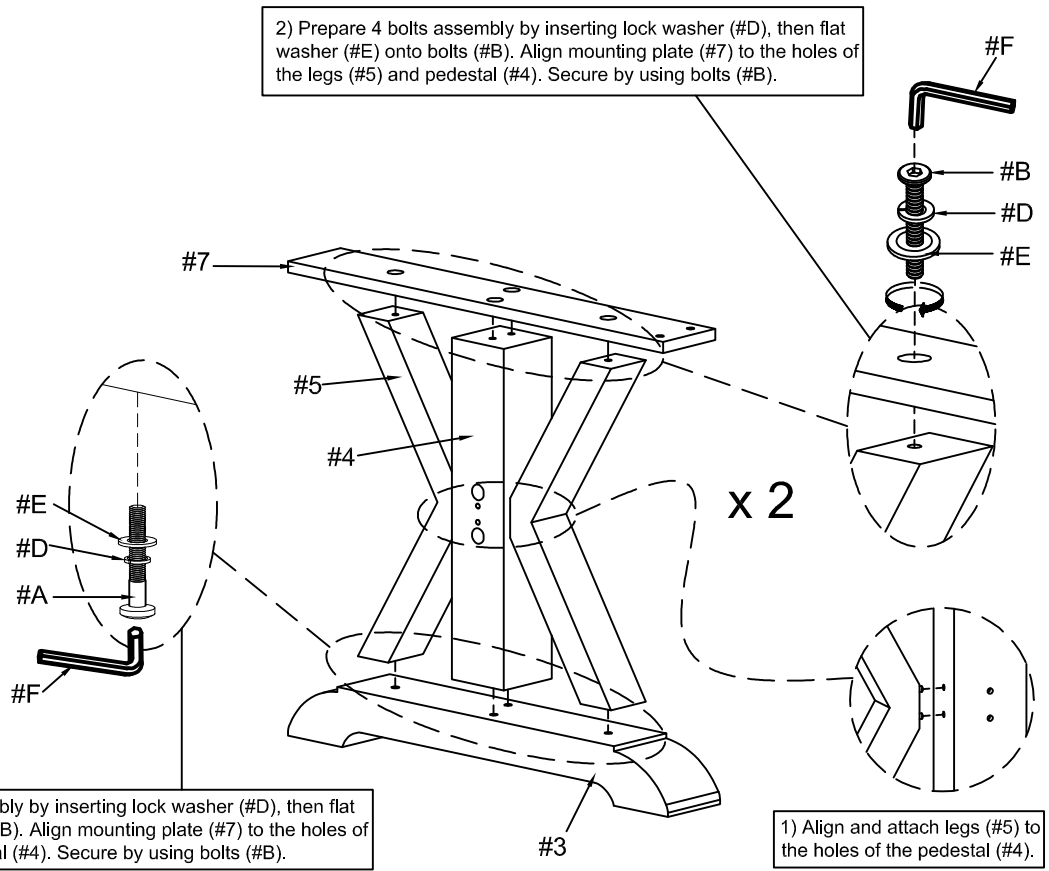

## 2

- Part #8 x1pc
- Hardware #A x4pcs
- Hardware #D x4pcs
- Hardware #E x4pcs
- Hardware #G x2pcs

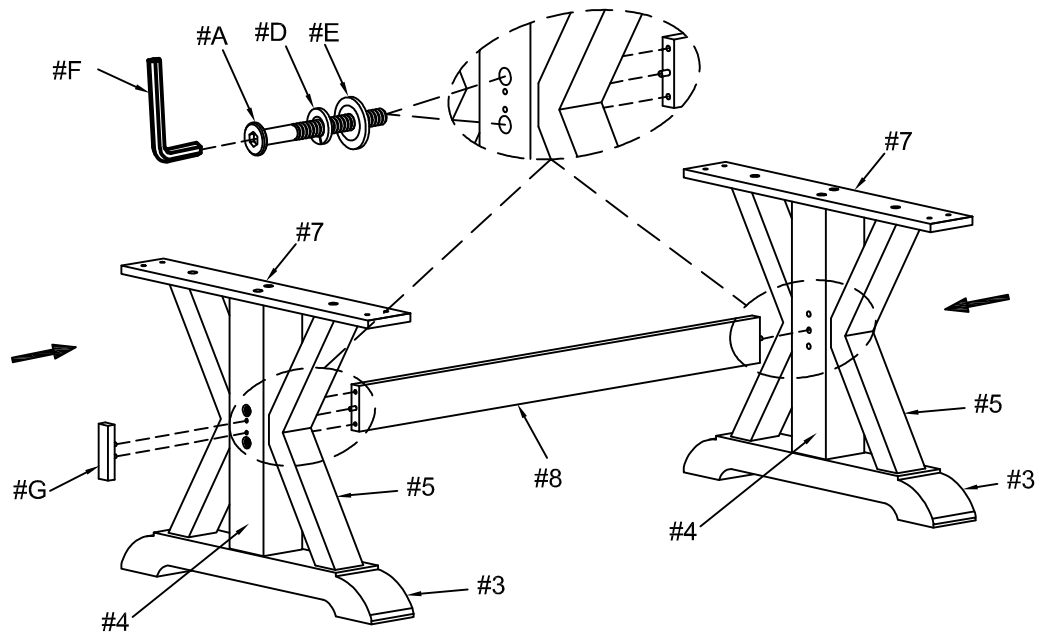

# ASSEMBLY INSTRUCTIONS

## 3

Part #1 x1pc

Part #6 x2pcs

Hardware #C x8pcs

Hardware #D x8pcs

Hardware #E x8pcs

Prepare 8 bolts assembly by inserting lock washer (#D), then flat washer (#E) onto bolts (#C). Align mounting plate (#6) to the holes of the table top (#1). Secure by using bolts (#C).

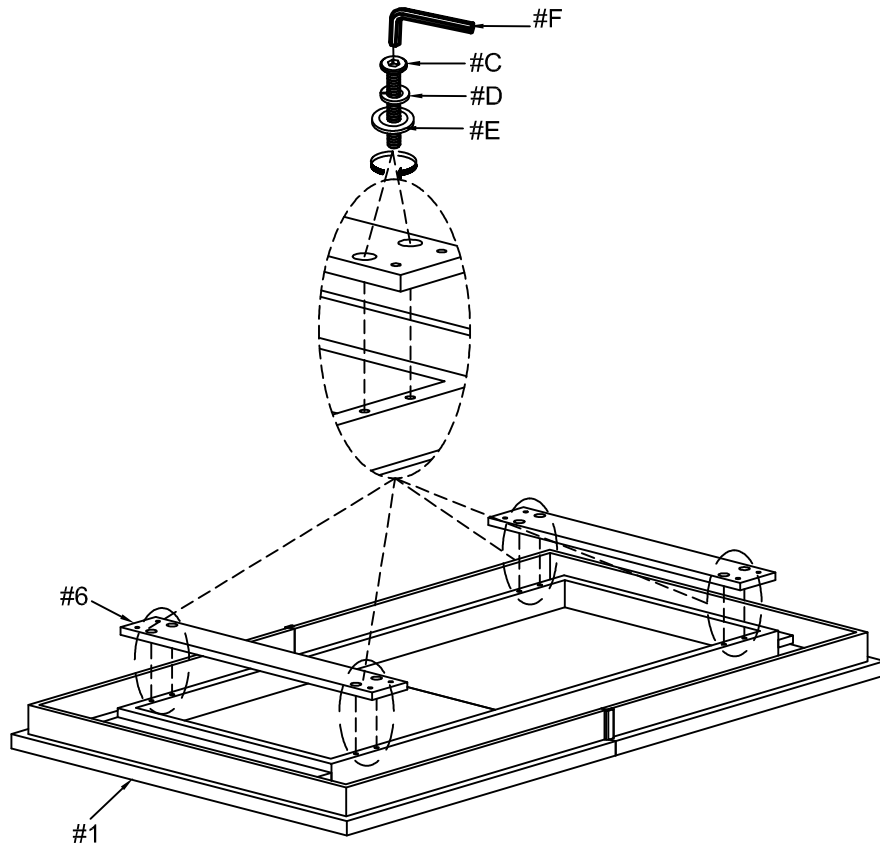

## 4

Hardware #C x8pcs

Hardware #D x8pcs

Hardware #E x8pcs

Prepare 8 bolts assembly by inserting lock washer (#D), then flat washer (#E) onto bolts (#C). Align mounting plate (#7) to the holes of the table top (#1). Secure by using bolts (#C).

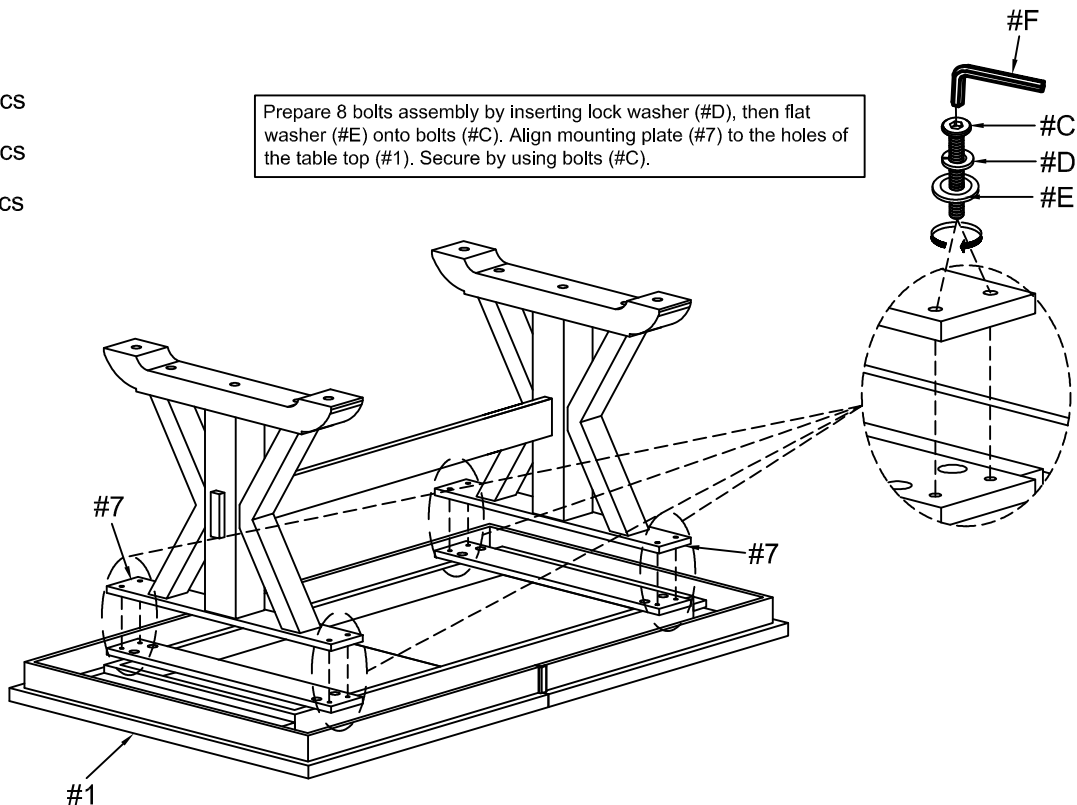

# ASSEMBLY INSTRUCTIONS

5

Part #2 x1pc

Turn lever to open.

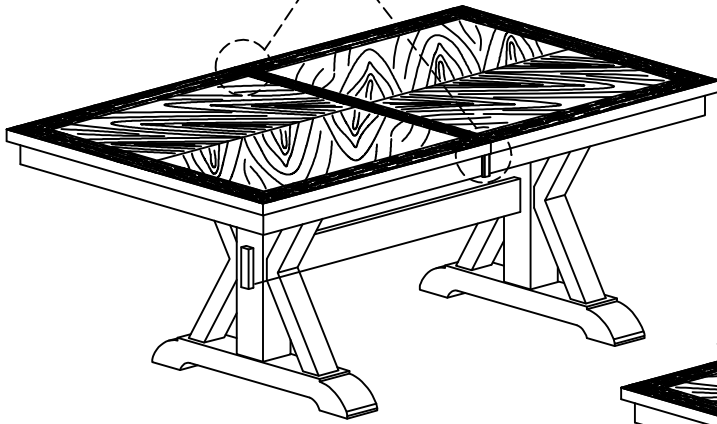
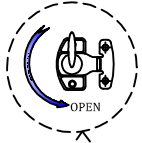

Extend table (#1), then place leaf (#2).

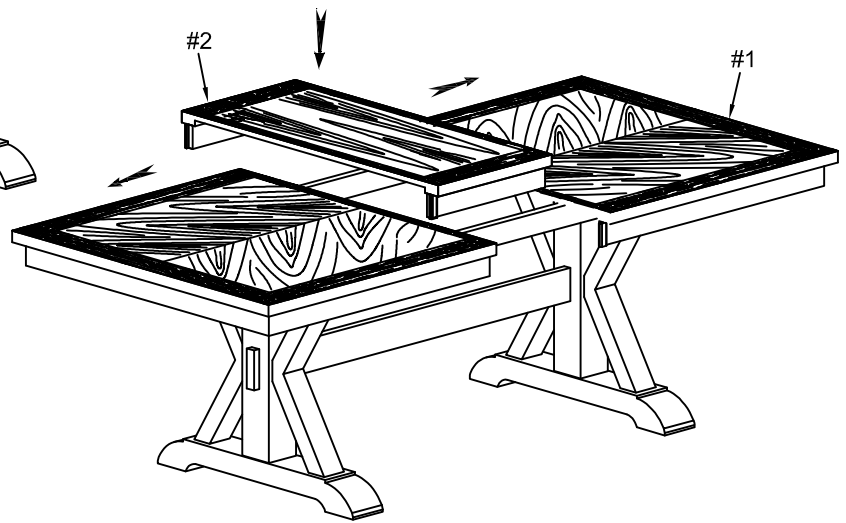

6

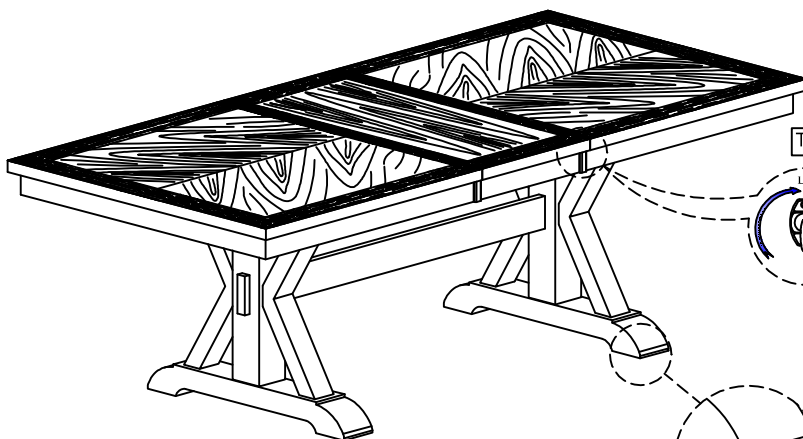

Turn lever to lock.

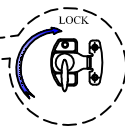

Adjust leveler of the base according to ground level.

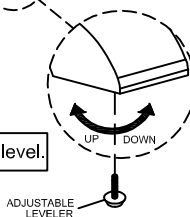

ADJUSTABLE  
LEVELER

## ASSEMBLY COMPLETED



Please ensure the furniture rests on an even and flat surface. If the product wobbles or feels loose, double-check all bolts and/or screws are properly tightened and secured.



### Keep this handy!

Please retain this instruction manual and any order-related information for future reference.



### Lift, don't drag!

To avoid damage to product please always LIFT the product when transporting or adjusting the placement.