

6 - Drawer Dresser

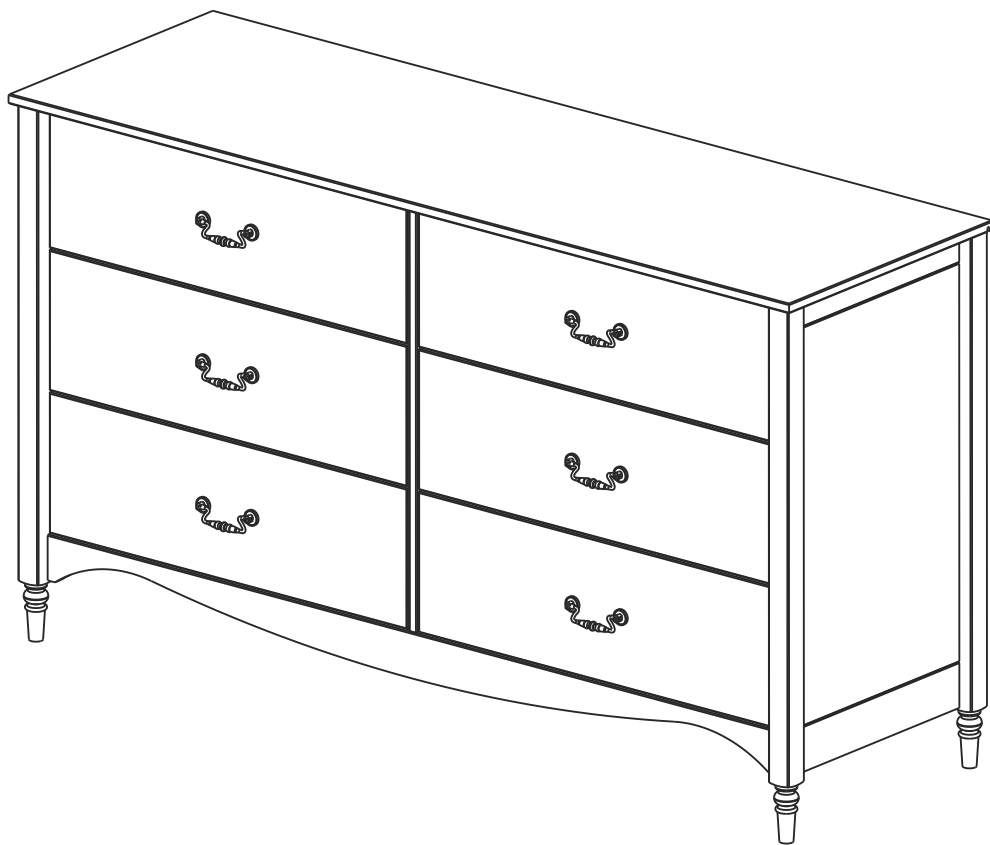

For Residential Use Only

Time to get started

Set up a clean and soft workplace to avoid damage during assembly. You can use the box and internal protections as a cover. It also helps to double-check if you have got all the pieces and parts before diving into the assembly.

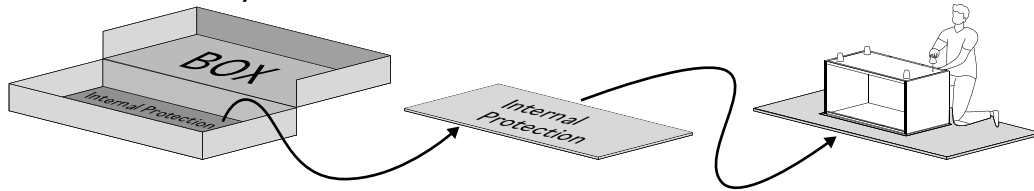

**Estimated time
for assembly**

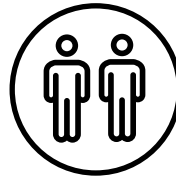

2 People Build

**People recommended
for assembly**

Make it a team effort!
Grab a friend for quicker,
easier assembly.

Tools Needed

Grab a Phillips head screwdriver and a hammer to conquer this assembly.

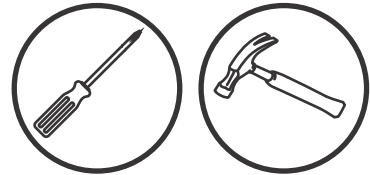

Use power tools with caution

This furniture is made of Solid Wood and Composite Wood, soft materials. If you choose to use power tools, set it to the slower setting. Be careful! Power tools can cause cracking or damage to the furniture, they can also damage the hardware if misused.

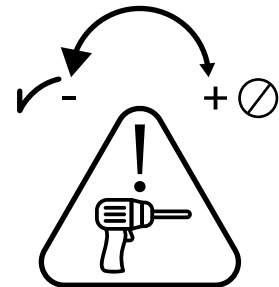

Parts List





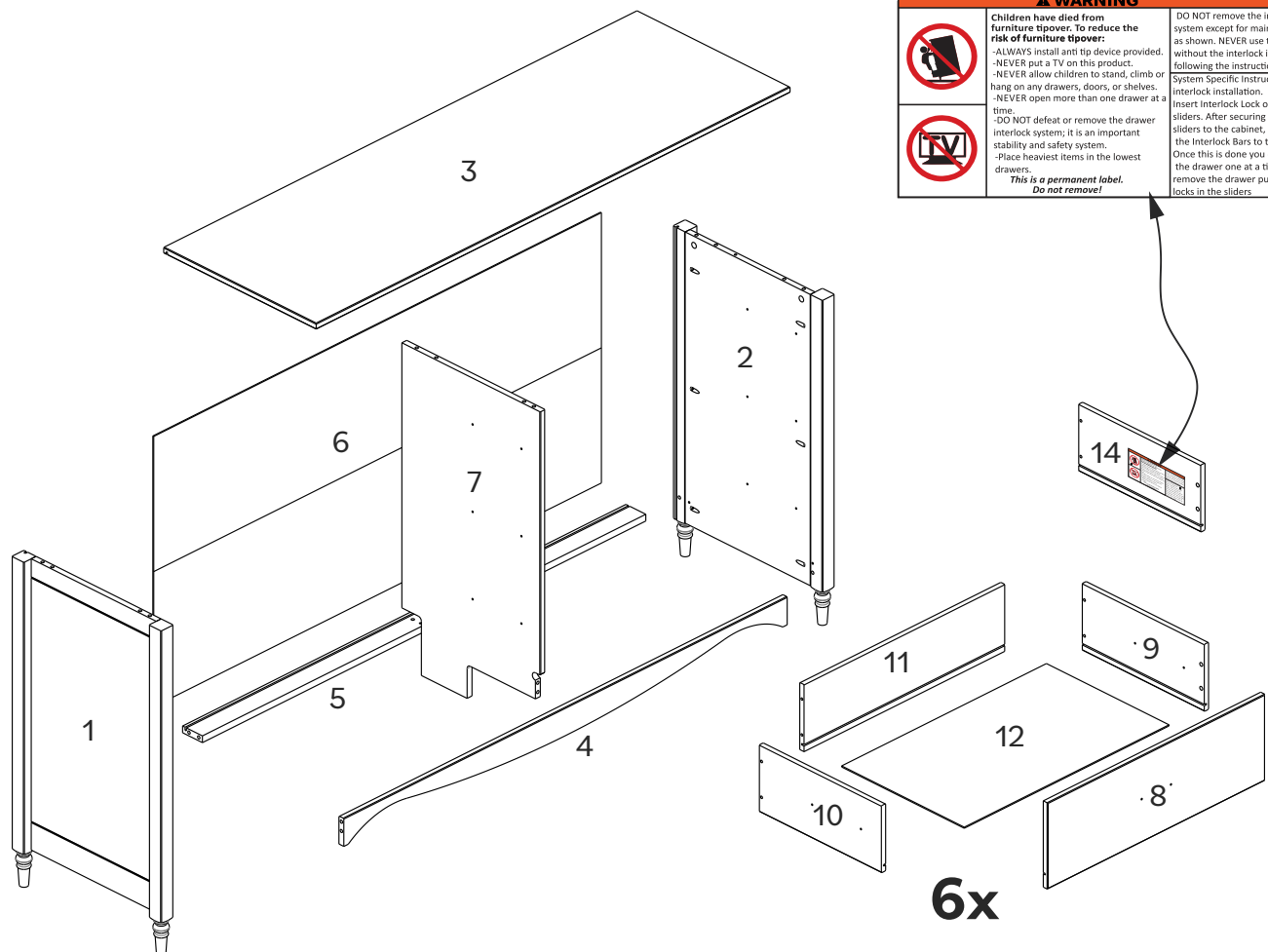









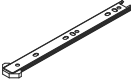

Part Number	Description	Quantity
1	Right Panel	1
2	Left Panel	1
3	Top Panel	1
4	Front Rail	1
5	Back Rail	1
6	Back Panel	1
7	Center Panel	1
8	Drawer Front	6
9	Right Drawer Side	5
10	Left Drawer Front	6
11	Drawer Back	6
12	Drawer Bottom	6
14	Right Drawer Side With Warning	1

The drawer side with the **WARNING LABEL**, should be placed as the highest drawer.



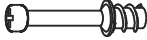

▲ WARNING		
	<p>Children have died from furniture tipover. To reduce the risk of furniture tipover:</p> <ul style="list-style-type: none"> -ALWAYS install anti tip device provided. -NEVER put a TV on this product. -NEVER allow children to stand, climb or hang on any drawers, doors, or shelves. -NEVER open more than one drawer at a time. 	<p>DO NOT remove the interlock system except for maintenance as shown. NEVER use the unit without the interlock installed following the instructions.</p> <p>System Specific Instructions for interlock installation.</p> <p>Insert Interlock Lock on the sliders. After securing the sliders to the cabinet, attach the Interlock Bars to the Locks. Once this is done you can place the drawer one at a time. To remove the drawer push the locks in the sliders.</p>
	<p>-DO NOT defeat or remove the drawer interlock system. It is an important stability and safety system.</p> <ul style="list-style-type: none"> -Place heaviest items in the lowest drawers. <p><i>This is a permanent label. Do not remove!</i></p>	

Hardware List

Part	Size	Name	Quantity
A		Dovetail	12
B		Dovetail Lock	24
C		Plastic Screw	24
D	 6x12mm	Screw	24
E		Interlock Lock	12
F	 6x14mm	Screw	24
G1	 250mm	Outer Slider	12
G2	 250mm	Inner Slider	12
H		Handle	6
I	 M4x19mm	Screw	12
J	 8x30mm	Wooden dowel	12
K		Leveling Bush	1
L		Leveling Foot	1
M	 6x31mm	Cam bolt	11
N	 15x11mm	Cam Lock	11
O		Interlock Bar	4
P		Wedge	14

*The hardware quantities listed above are required for proper assembly.
Extra hardware pieces may be included.*

Hardware List

	Part	Size	Name	Quantity
Q		4x40mm	Screw	2
R			Wall anchor	1
S		4x16mm	Screw	1
T		6x35mm	Plastic bush	1
U			Washer	2
V		3,5X14mm	Screw	14

*The hardware quantities listed above are required for proper assembly.
Extra hardware pieces may be included.*

Introducing The Easy Assembly Drawer System

Say Goodbye to Assembly Hassle!

We understand that assembling drawers can be the most time-consuming and tedious part of putting together your new furniture. That's why we've developed the Easy Assembly Drawer System - to make the process easy!

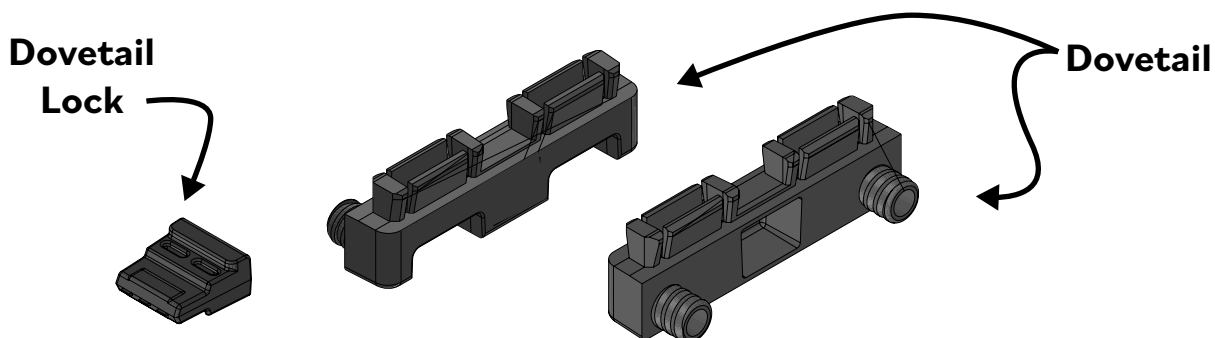

Why You'll Love Our Easy Assembly Drawer System:

Quick & Easy: Our new drawer hardware significantly reduces your assembly time. Get it done in no time!

Minimal Effort Required: Designed to be super simple, you'll need little to no tools to get the job done.

Built to Last: Strong and sturdy, our system ensures that your drawers stay solid and reliable.

Let's set the stage to assembly:

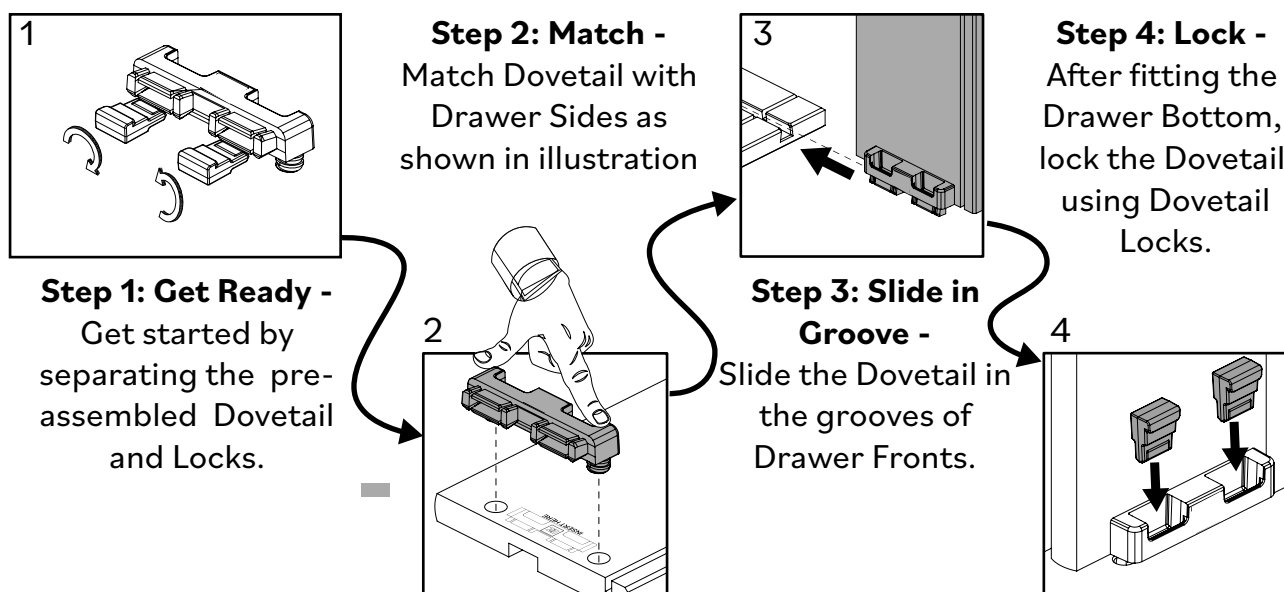

Attention: In the next steps there are more details to help you assemble.

Step 1

Prepare the Dovetails (A) by removing the Dovetail Locks (B) from the Dovetails (A).

1st

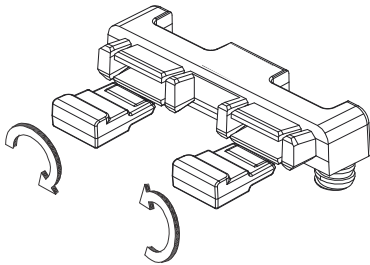

2nd

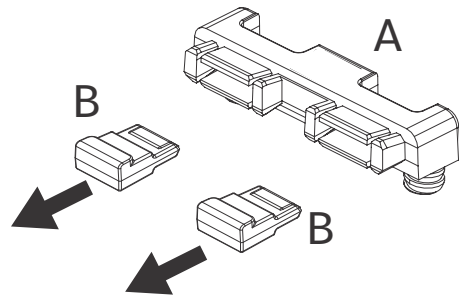

Step 2

Snap the Dovetails (A) into place on Right Drawer Sides (9 and 14) and Left Drawer Sides (10). Press the Dovetails until they are completely attached. Use a hammer if necessary.

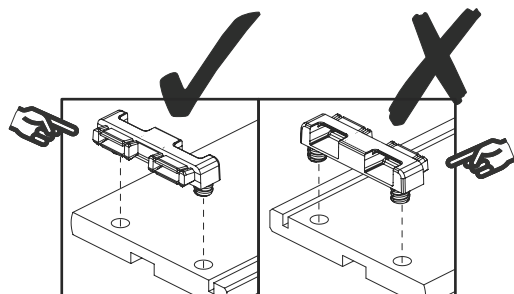

Press the piece until it is completely attached

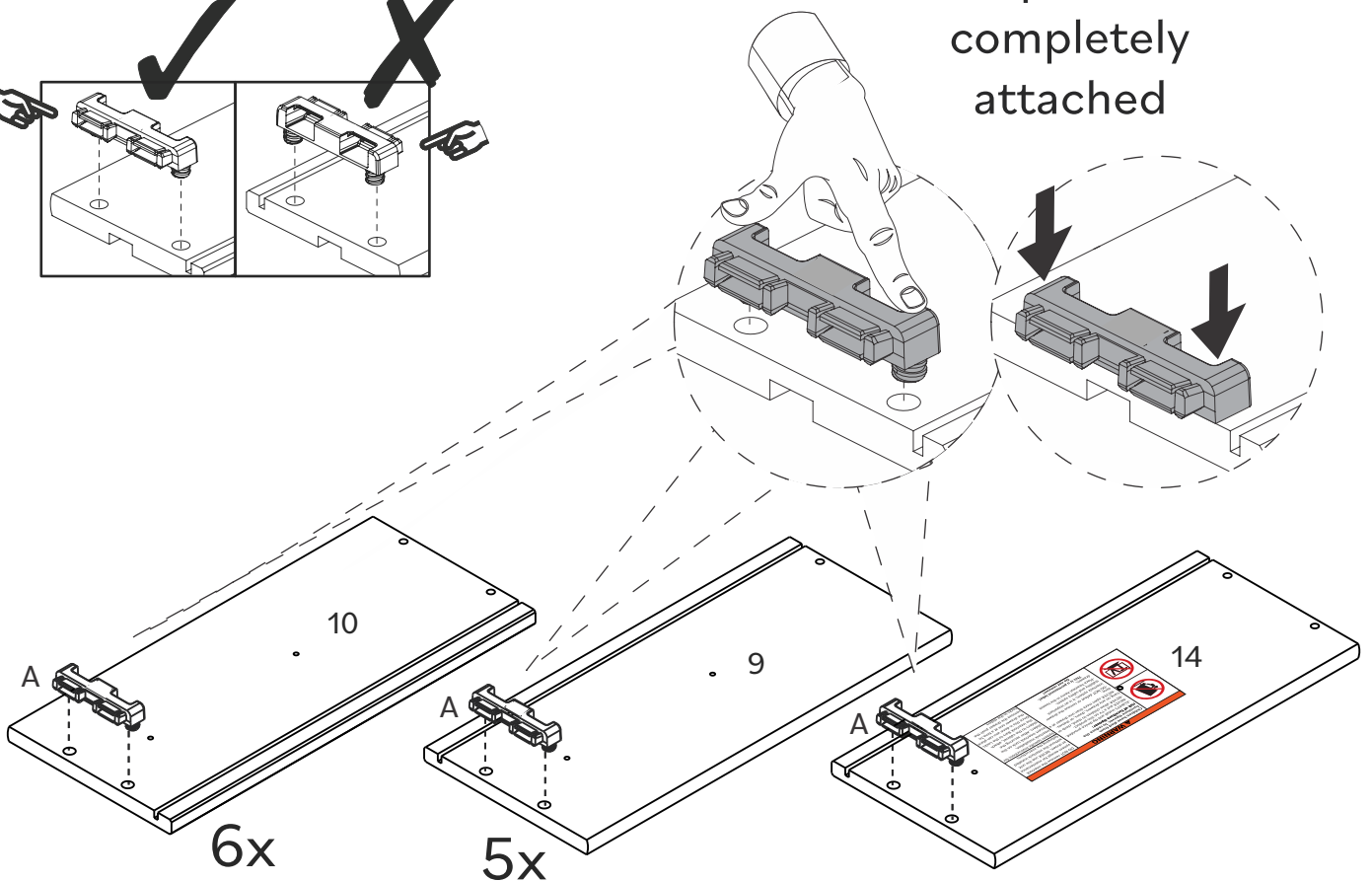

Step 3

Slide the Dovetail (A) on the Right Drawer Panel (9/14) and Left Drawer Panel (10) into the grooves on the Drawer Front (8).

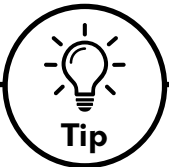
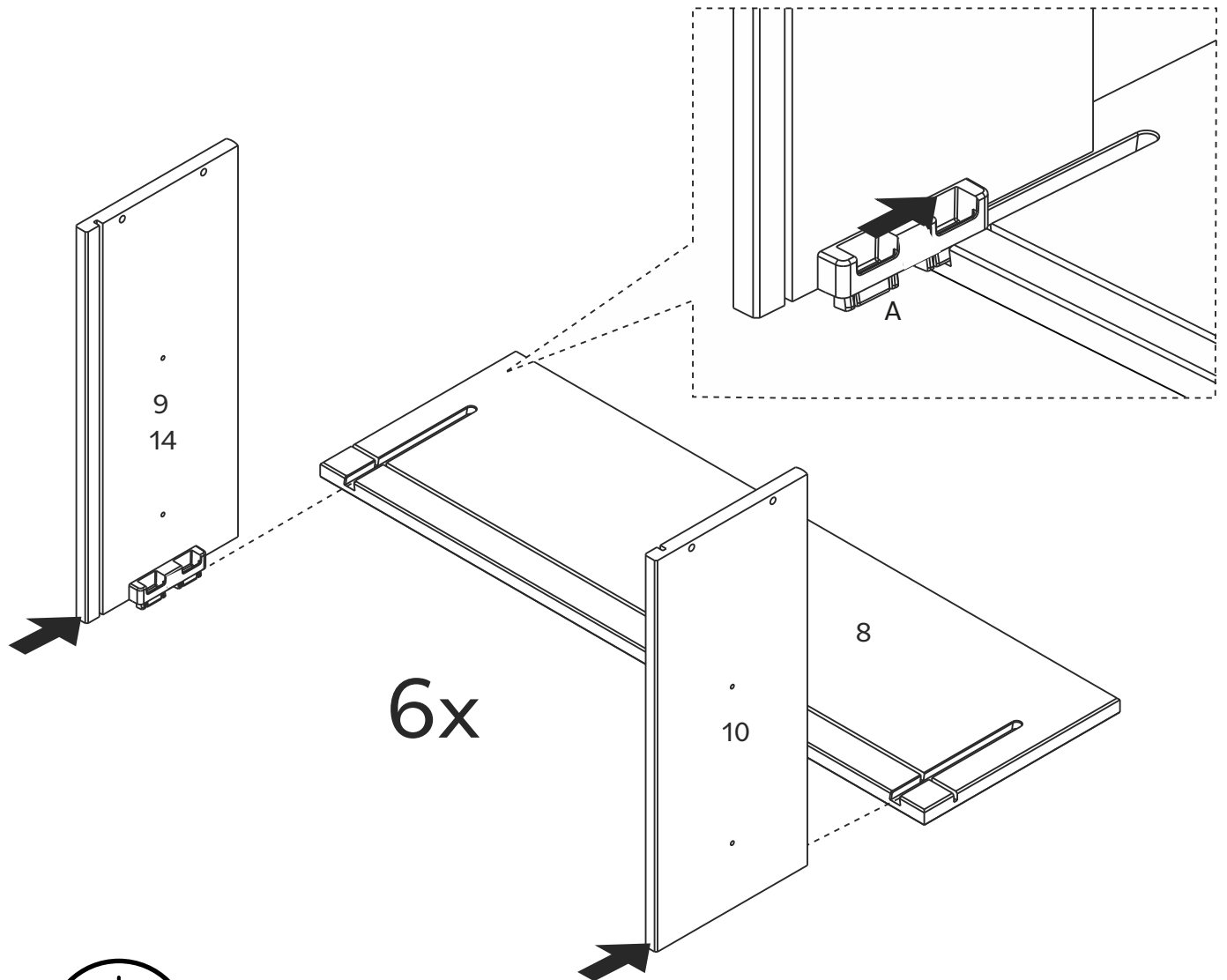

To keep your product looking its best and scratch-free, try assembling it on a soft surface like carpet or a blanket. This helps prevent any accidental scratches and keeps your furniture in top shape!

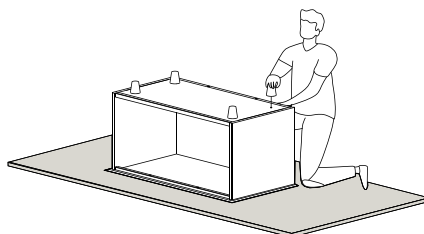

Step 4

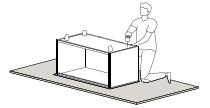

Slide Drawer Bottom (12) between the grooves on Right Drawer Side (9 and 14) and Left Drawer Side (10) fitting in Drawer Front (8).

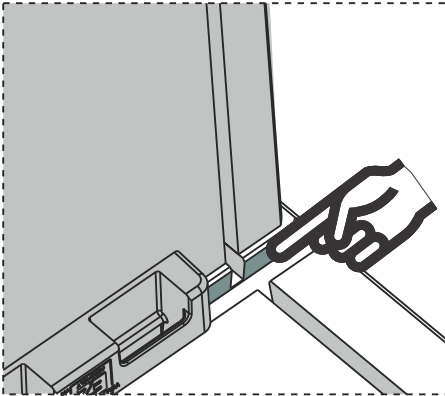

Align the grooves on the Drawer Sides and Drawer Front to receive the Drawer Bottom

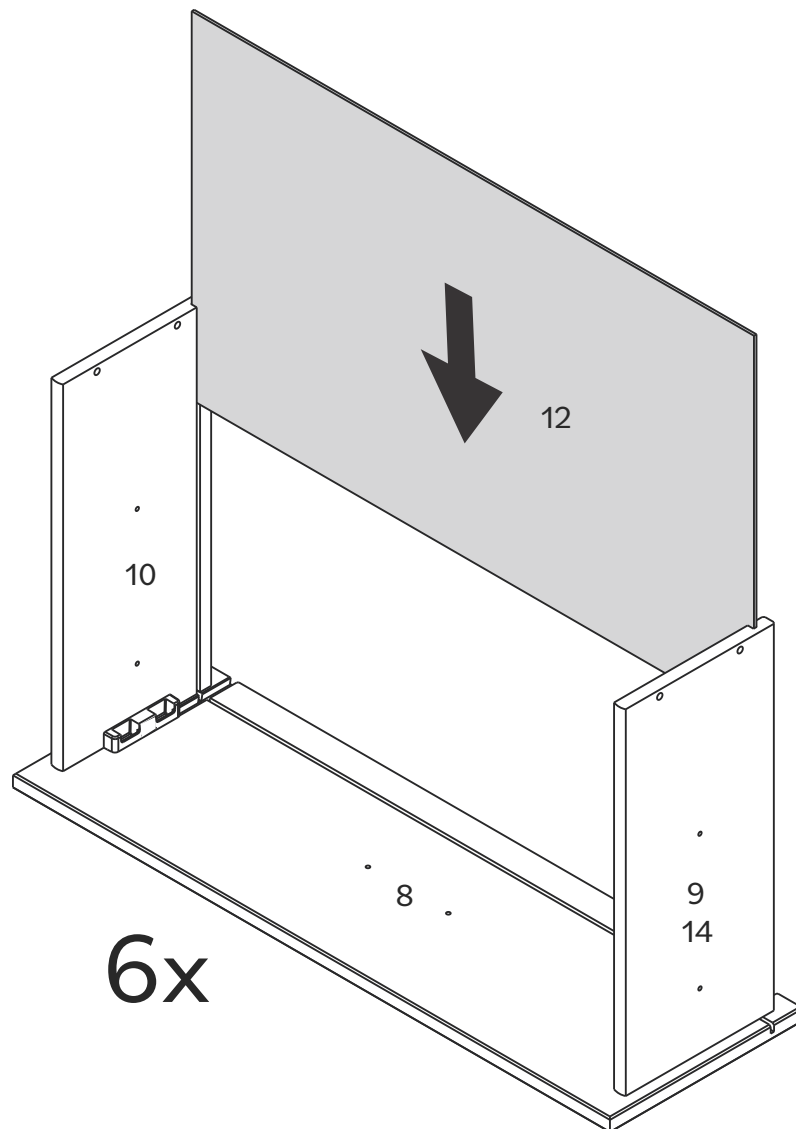

Step 5



To secure the Drawer sides, insert the Dovetail Locks (B) into the Dovetails (A). Use a hammer if necessary.

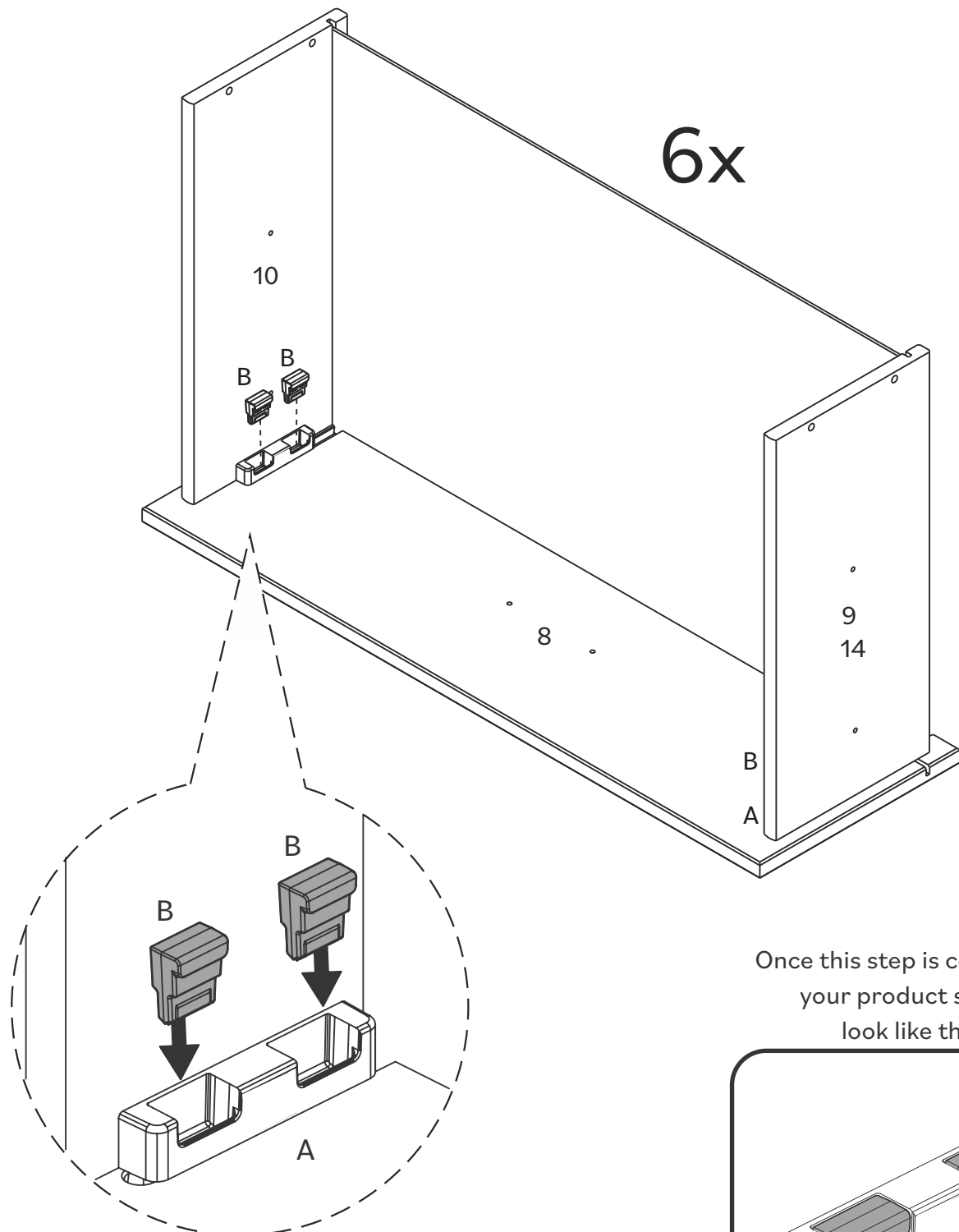

Once this step is completed, your product should look like this:

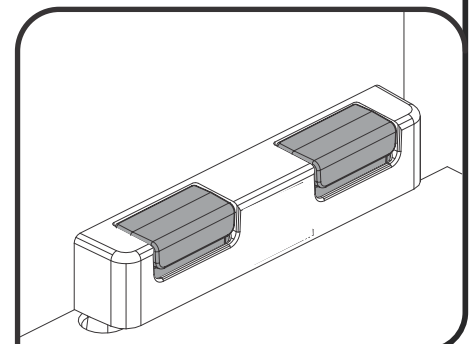

Step 6



Fit Drawer Bottom (12) to Drawer Back (11) and secure using Plastic Screw (C), you can insert it with your hands or using a hammer.

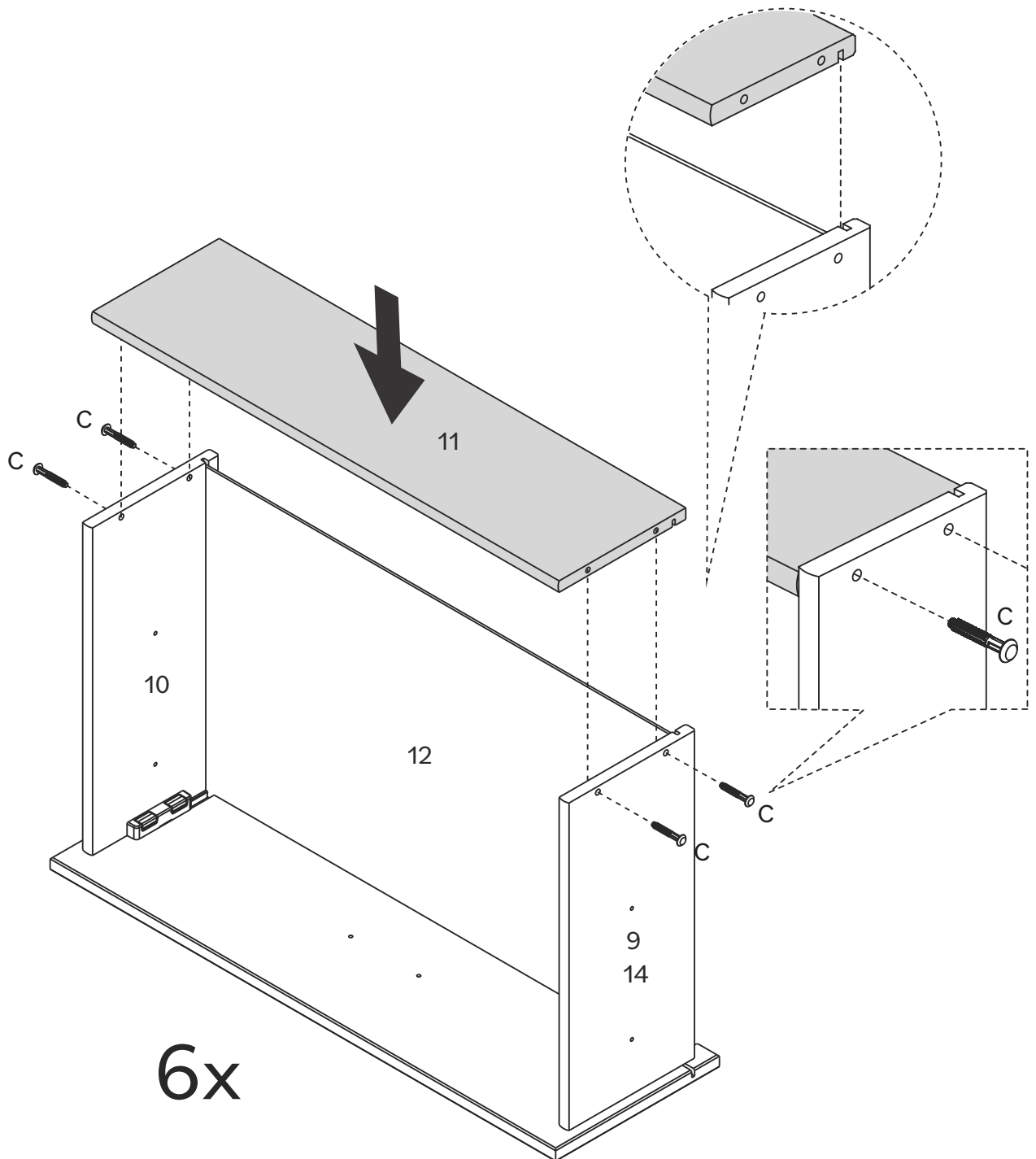

Step 7



Attach Inner Sliders (G2) to Right Drawer Sides (9 and 14) and Left Drawer Sides (10) using Screw (D) and a Phillips screwdriver.

Separate parts G1 and G2 by pressing the lock.

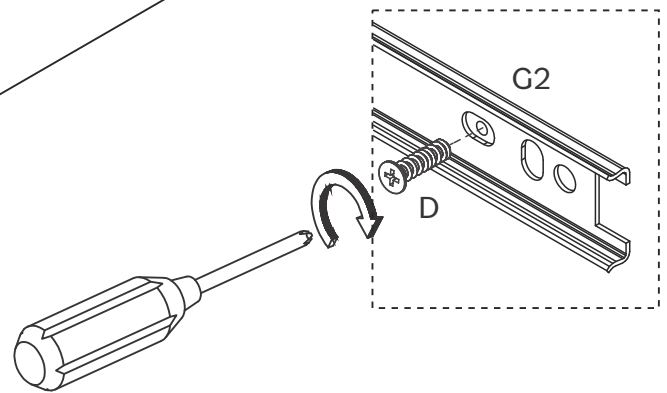
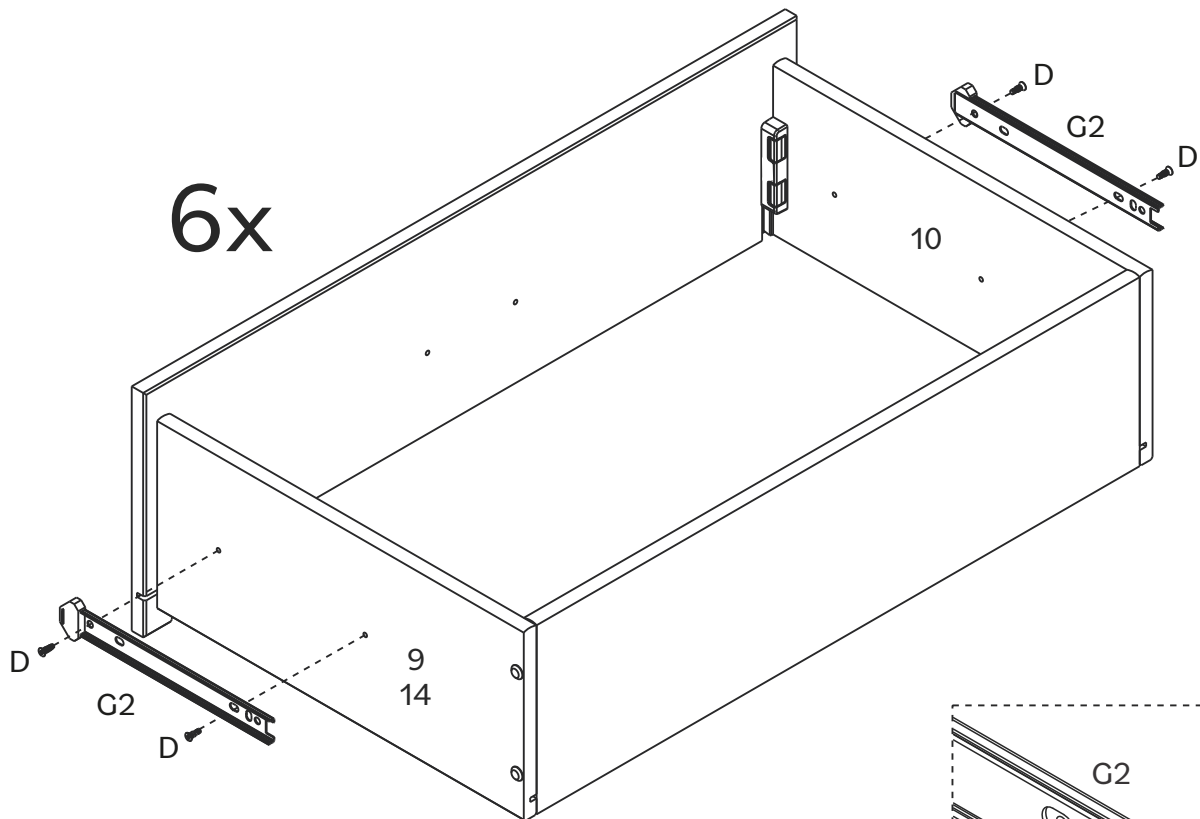
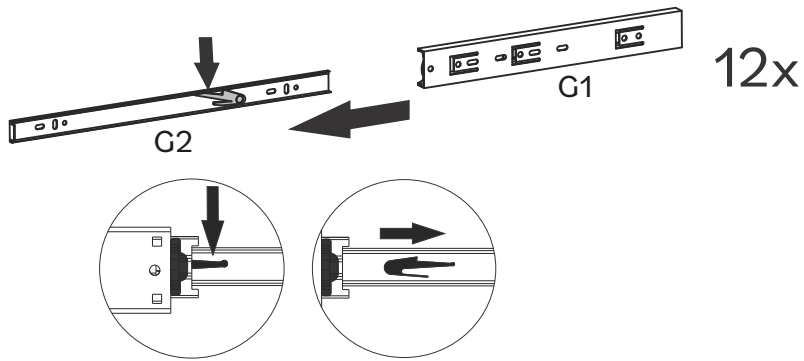

Step 8



Use Screws (I) and a Phillips screwdriver to secure Handles (H) to Drawer Fronts (8).

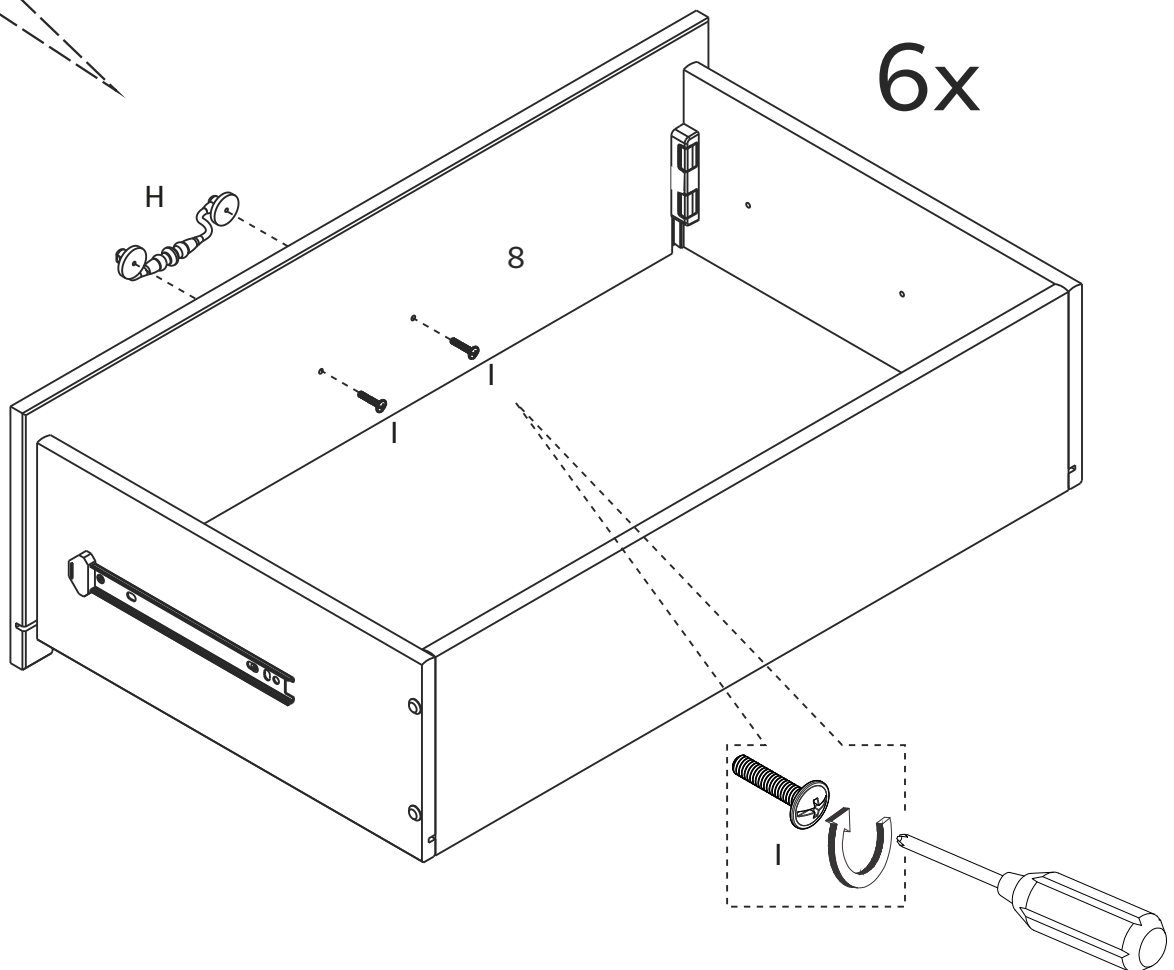
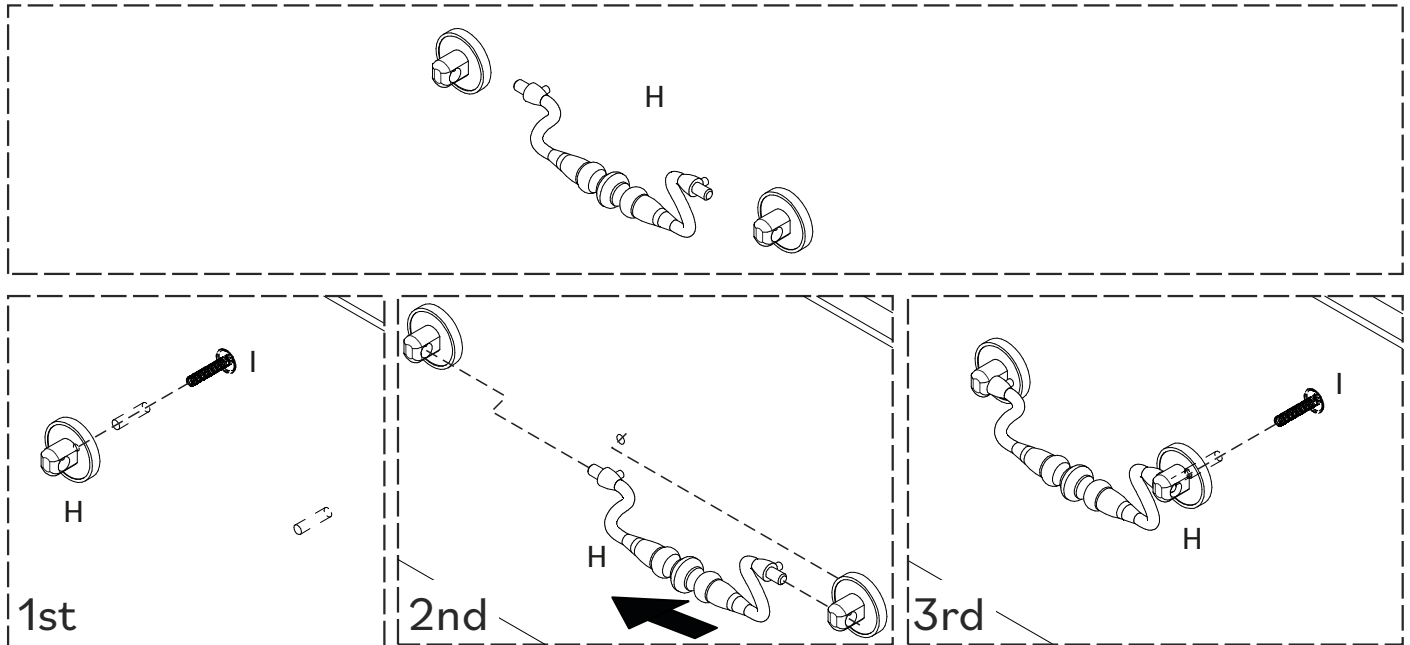

Step 9



Insert Wooden Dowels (J) into Left Panel (1), Right Panel (2), Front Rail (4), Back Rail (5) and Center Panel (7).

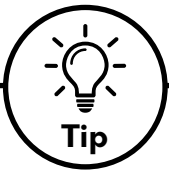
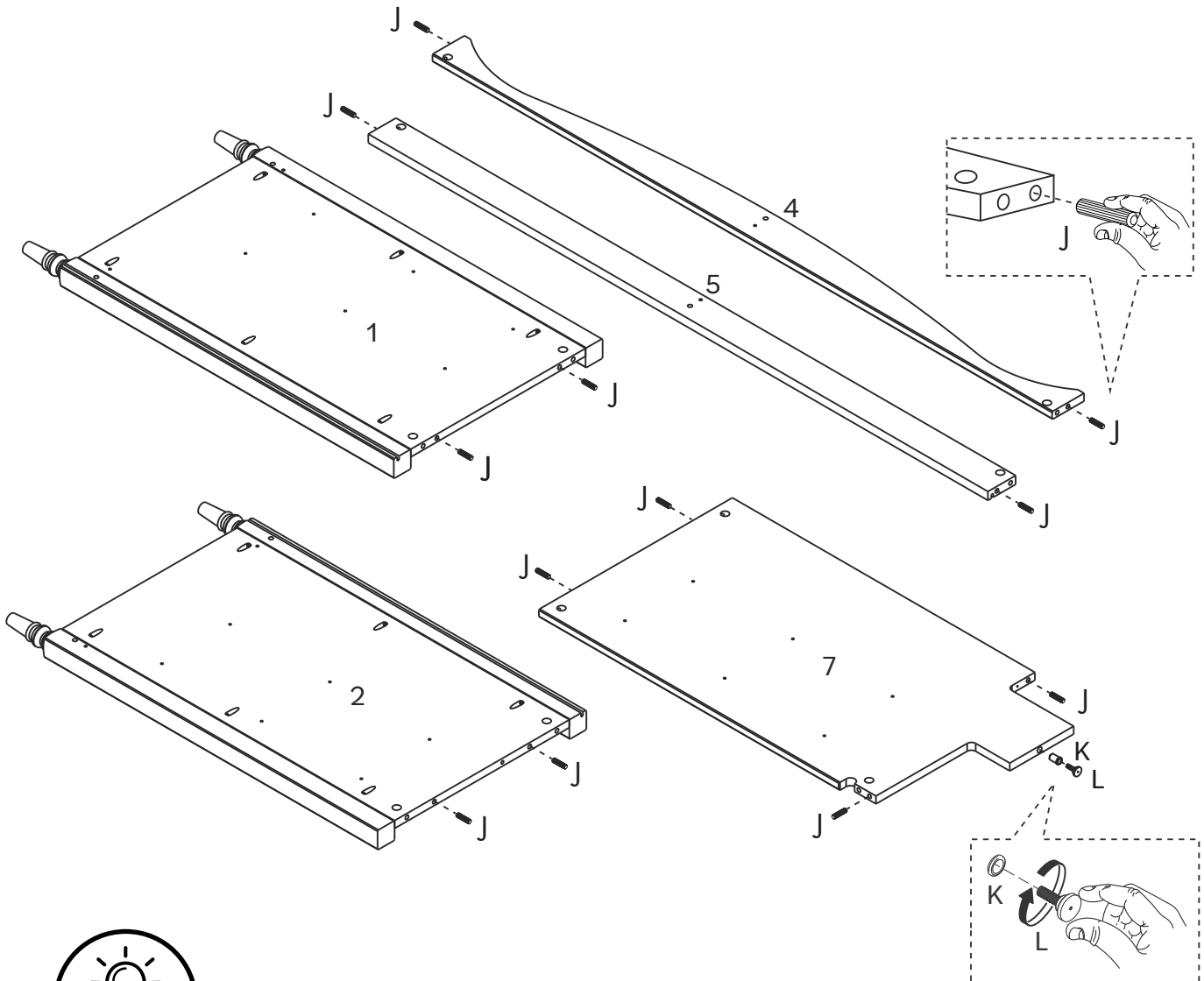

Tip

Wood Dowels

Dowels are essential in furniture assembly to create strong, precise connections. They ensure structural integrity, prevent shifting, and simplify alignment, resulting in sturdier, longer-lasting furniture.

Follow these steps:

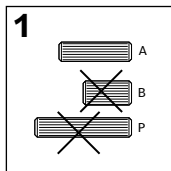

1: Select the appropriatedowel listed in the step.

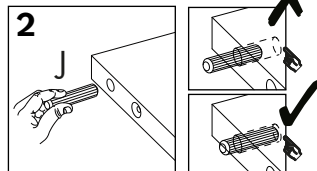

2: Insert into drilled hole and press firmly to ensure placement is set.

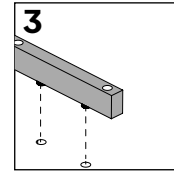

3: Align the dowel with corresponding piece and press together until secure.

Step 10

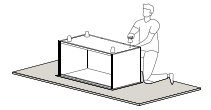

Attach Cam Bolts (M) to Left Panel (1), Right Panel (2), Top Panel (3) and Front Rail (5).

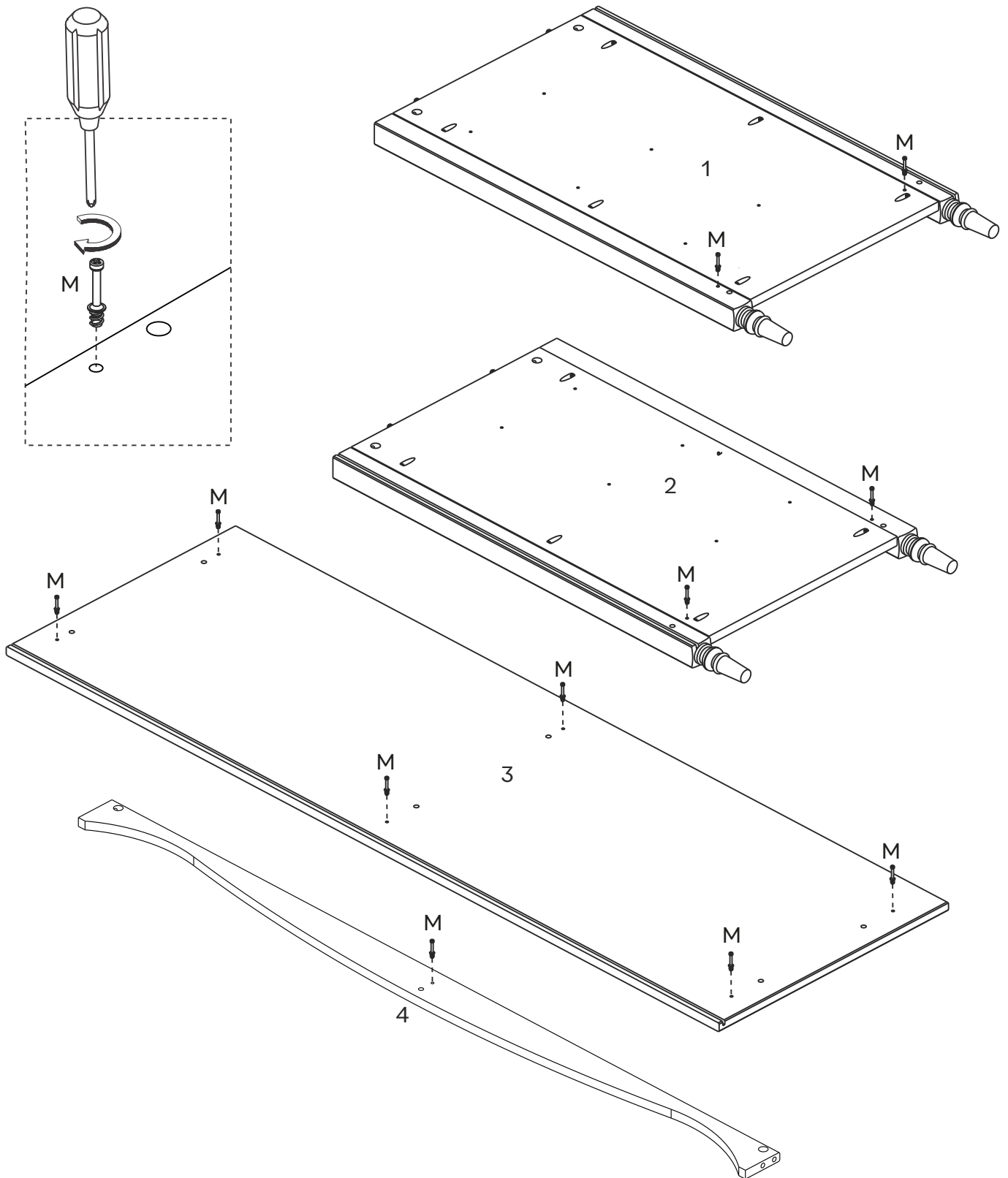

Step 11

Take Outer Slider (G1) and insert Interlock Lock (E) according to the diagram below.

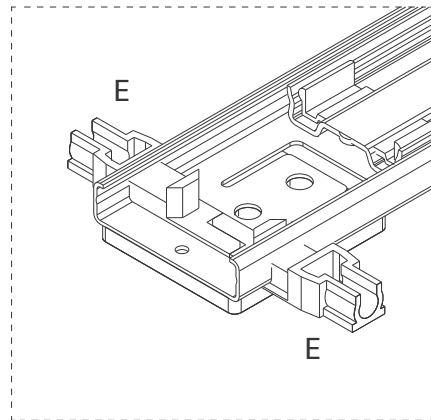
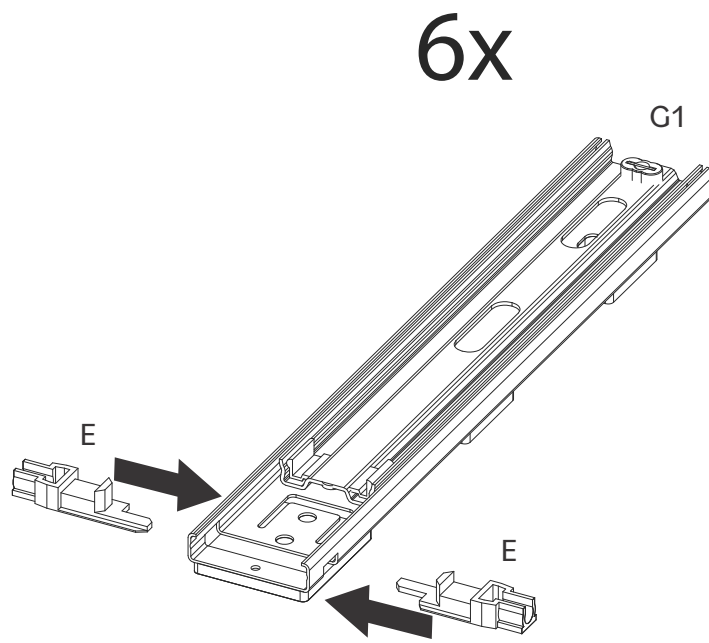

Step 12

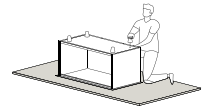

Secure Outer Slider (G1) to Right Panel (2) and Left Panel (1) using Screw (F) and a Phillips screwdriver.

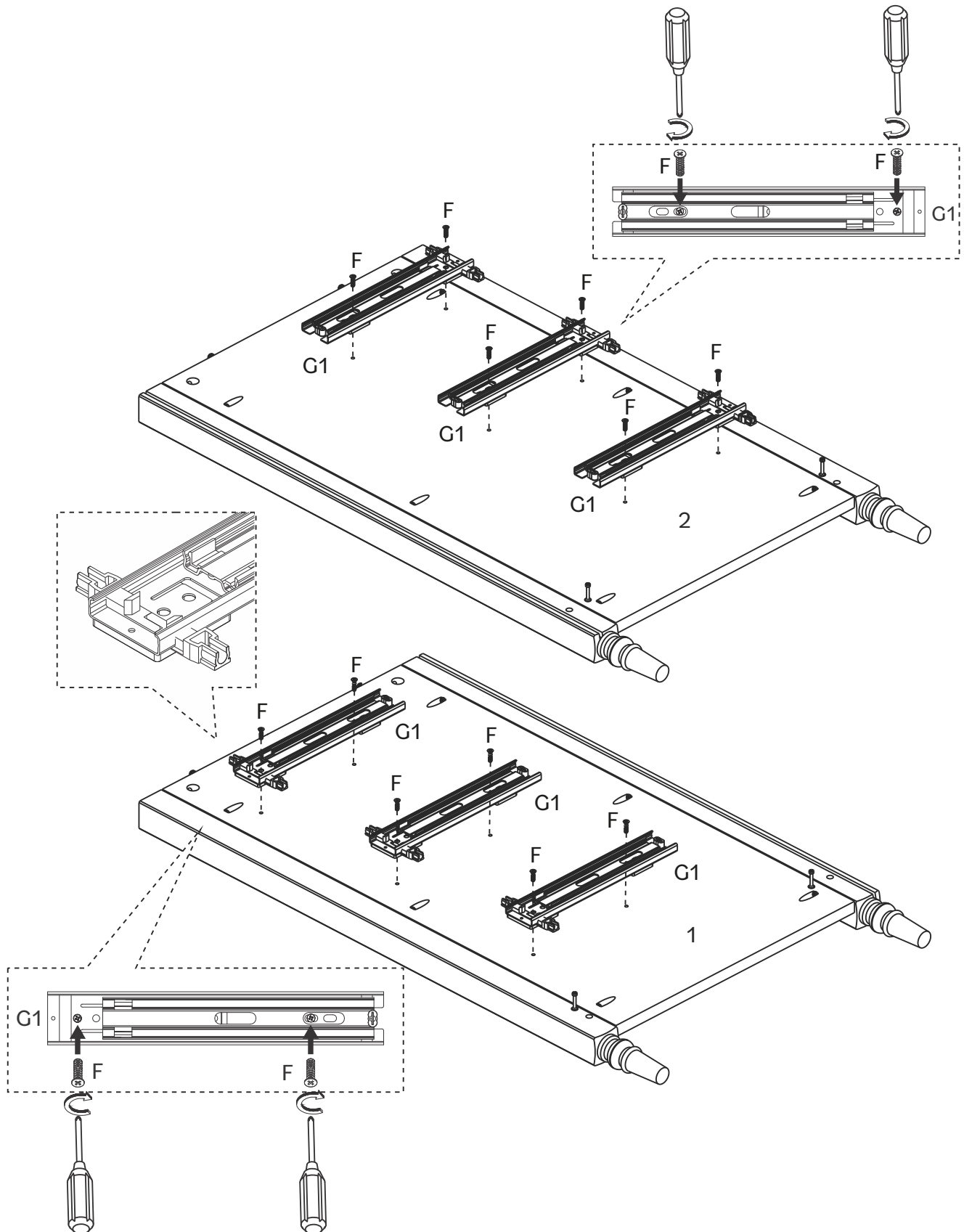

Step 13

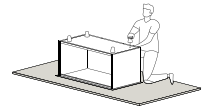

Secure Outer Slider (G1) to both sides of Center Panel (7) using Screw (F) and a Phillips Screwdriver.

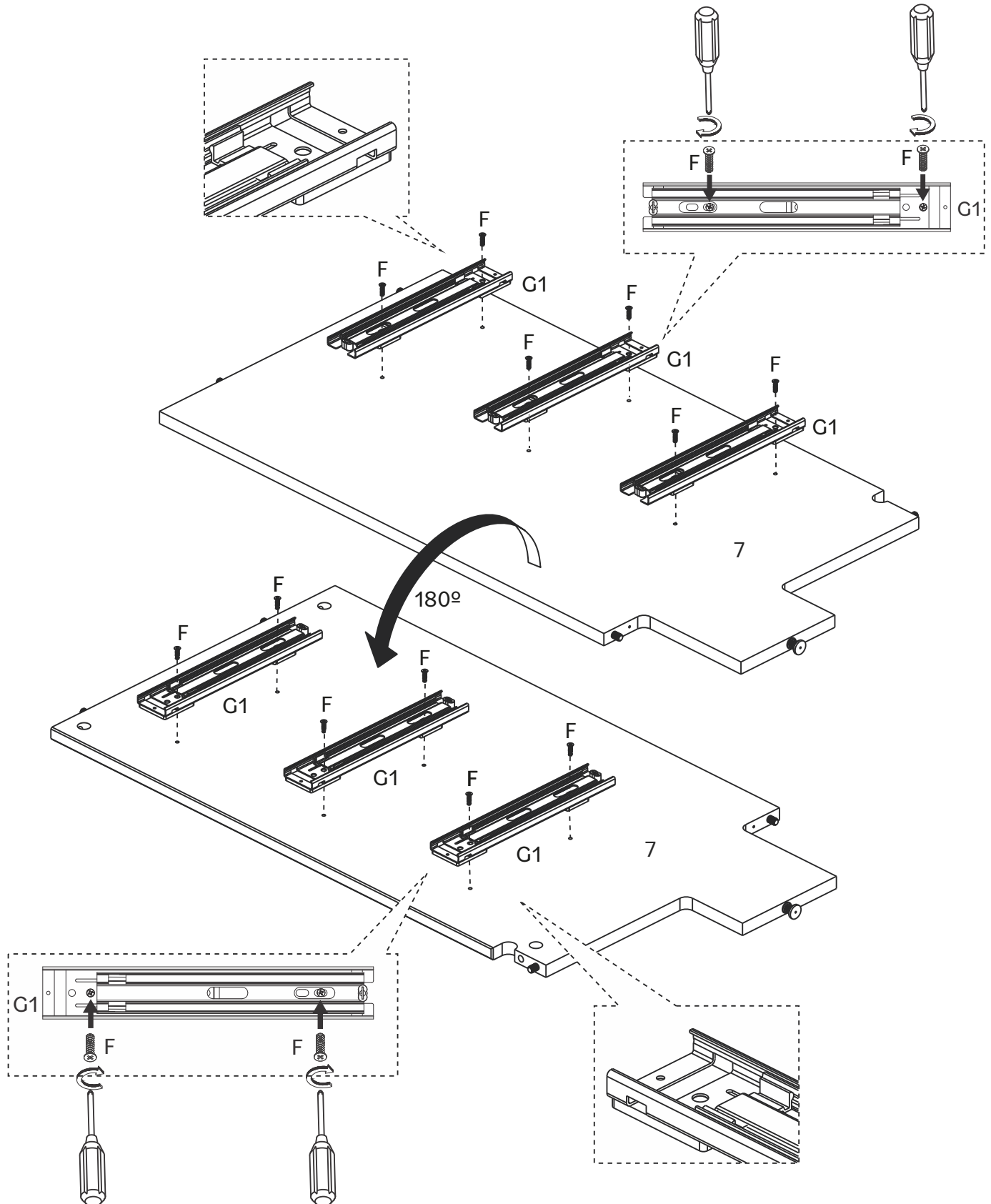

Step 14



Attach Back Rail (5) to Right Panel (2) using Cam Lock (N) and a Phillips screwdriver.

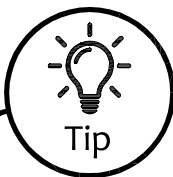
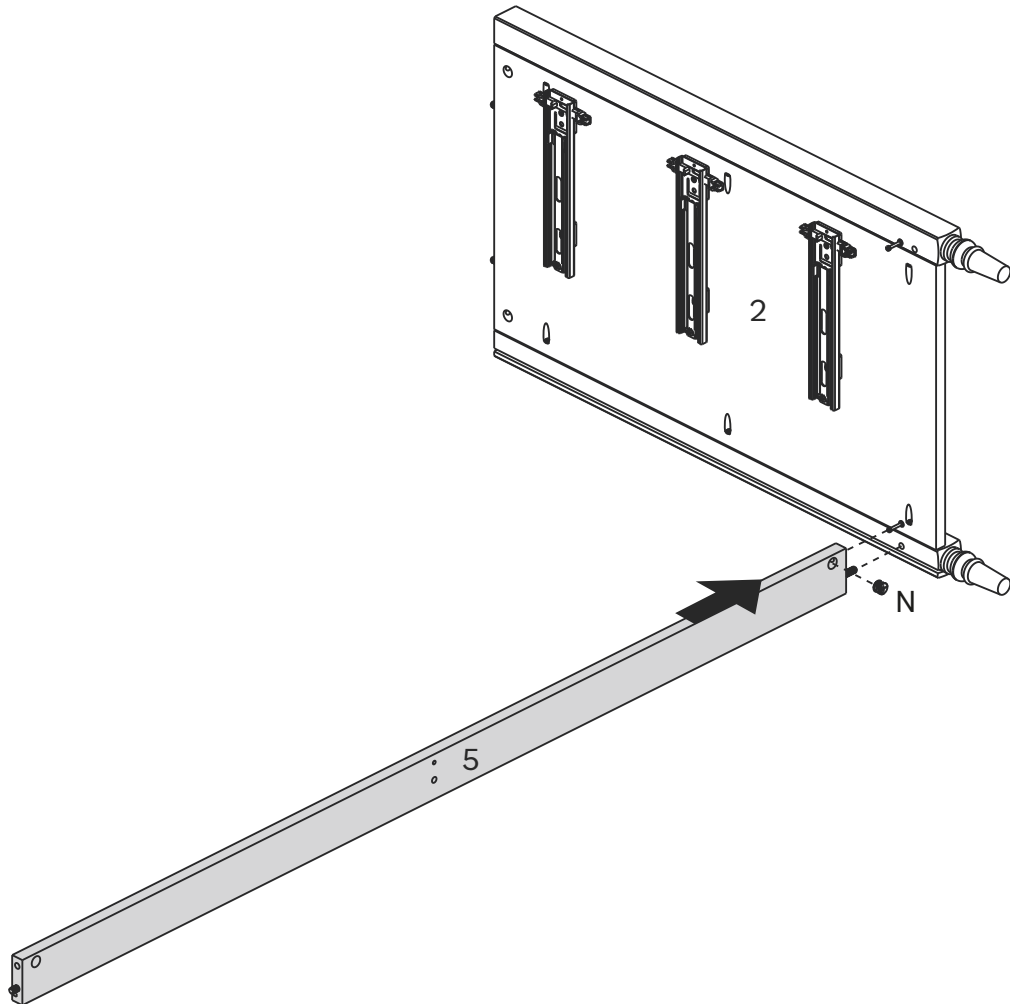

Tip

Cam Locks

Cam Locks help to securely join two pieces together. Follow these easy steps.

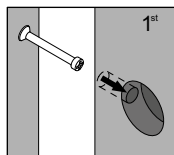

1: Insert Cam Bolt into bolt holes on the flat side. Don't over tighten!

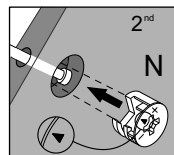

2: Assemble both parts together. The cam bolts go in the drill holes that have a circular hole on the side, you should be able to see the cam bolt through it. After fitting parts together insert the cam lock in the side holes.

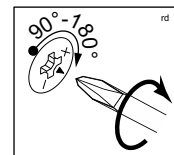

3: On the back of the Cam Lock will be a "C" shape. Insert the Cam Lock so the opening of the "C" fits over the Cam Bolt. Tighten with the screwdriver.

Step 15



Join Center Panel (7) to Back Rail (5) using screw (Q) and a Phillips screwdriver.

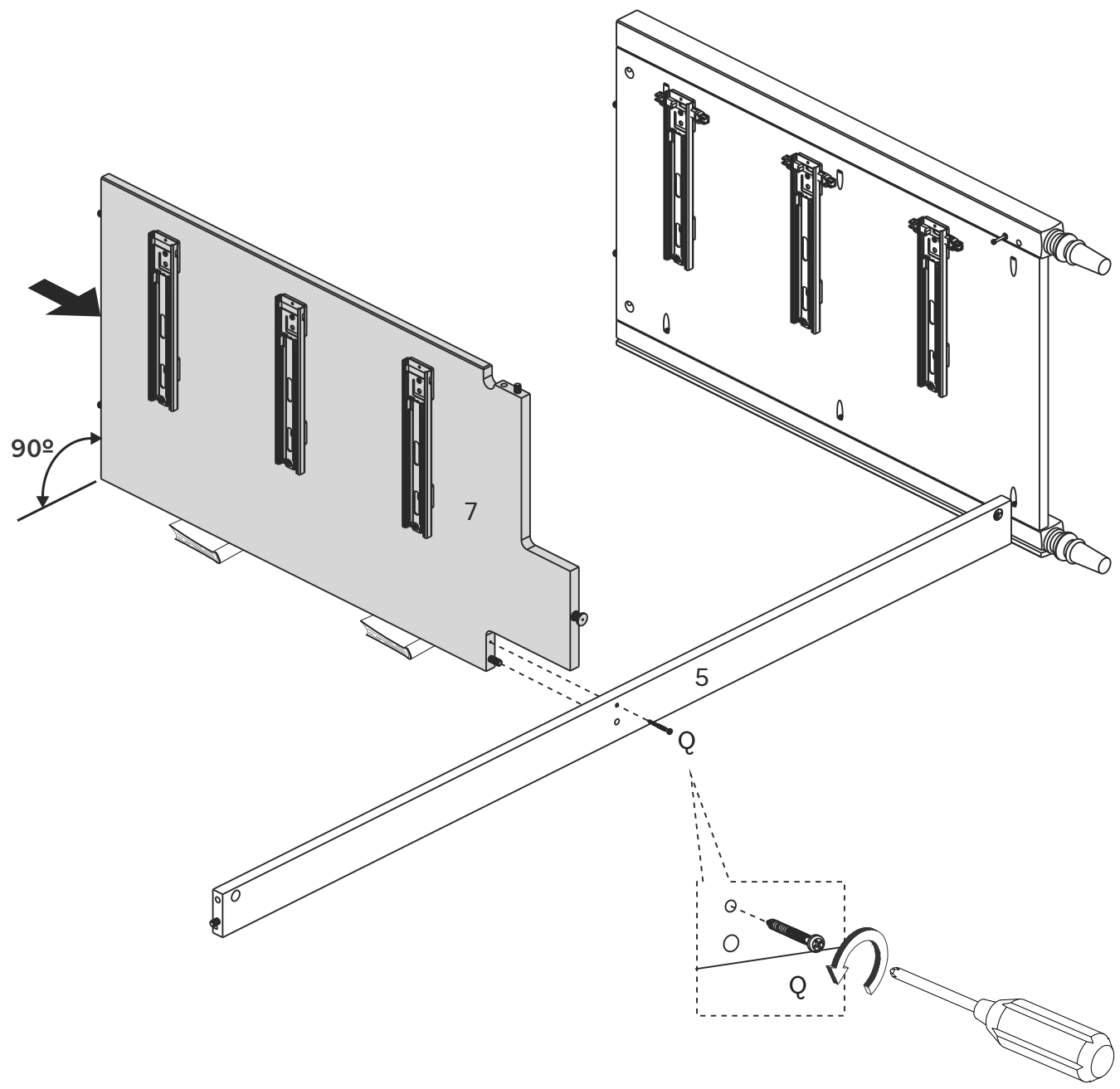

Step 16



Join Front Rail (4) to Right Panel (2) and Center Panel (7) using Cam Lock (N) and a Phillips screwdriver.

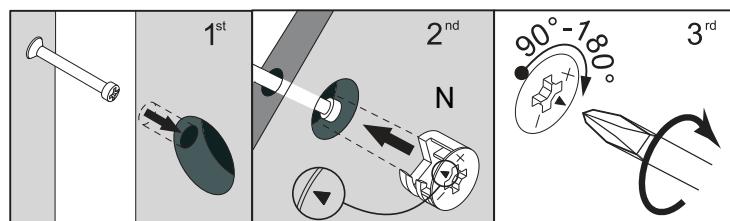
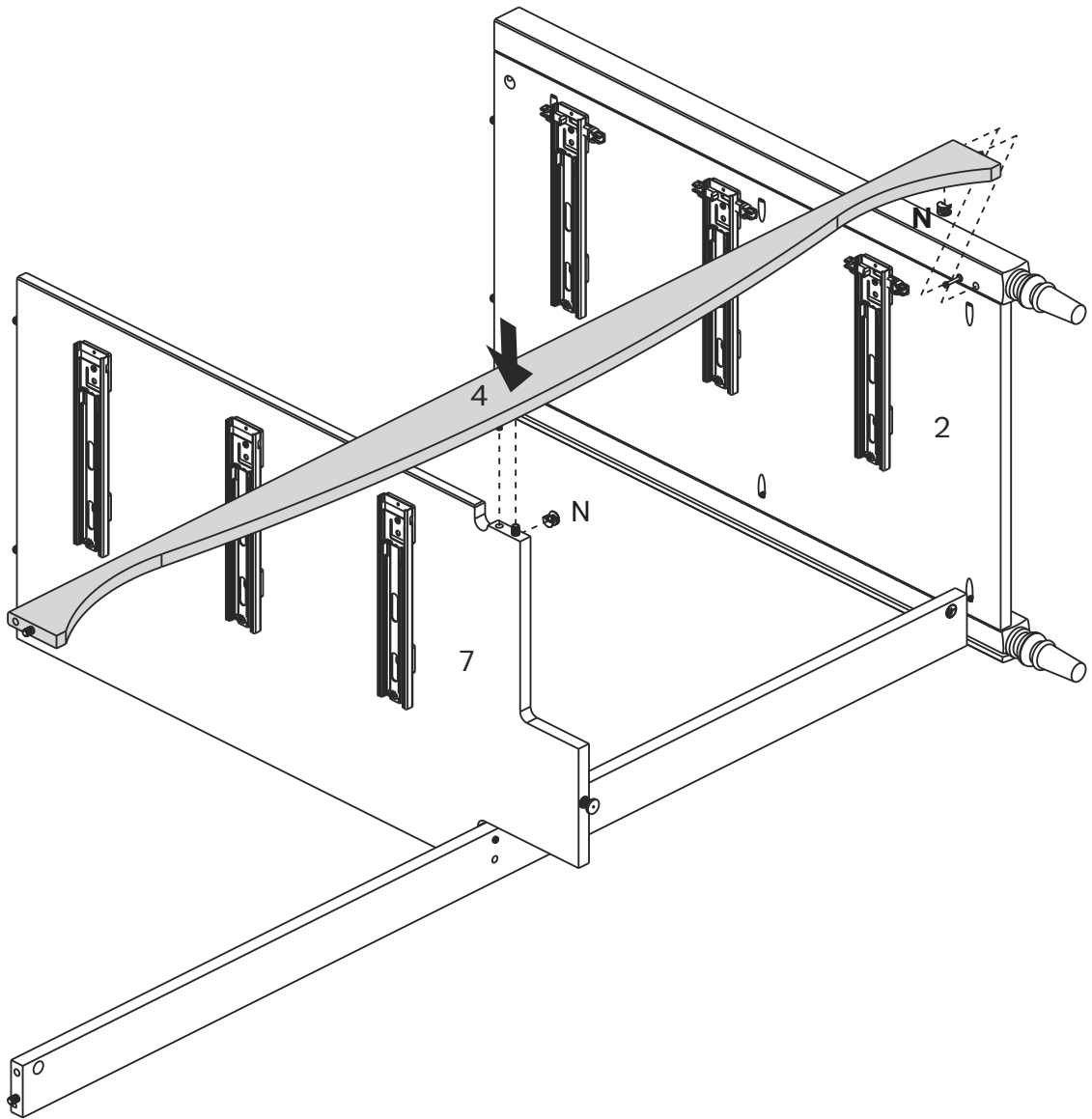

Step 17



Join Left Panel (1) to Front Rail (4) and Back Rail (5) using Cam Lock (N) and a Phillips screwdriver.

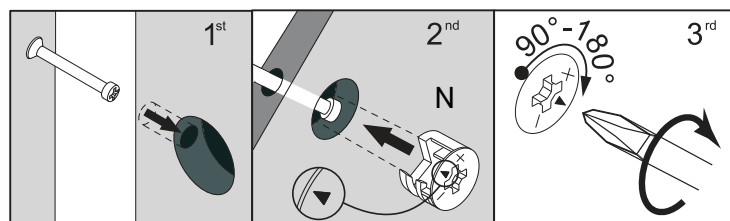
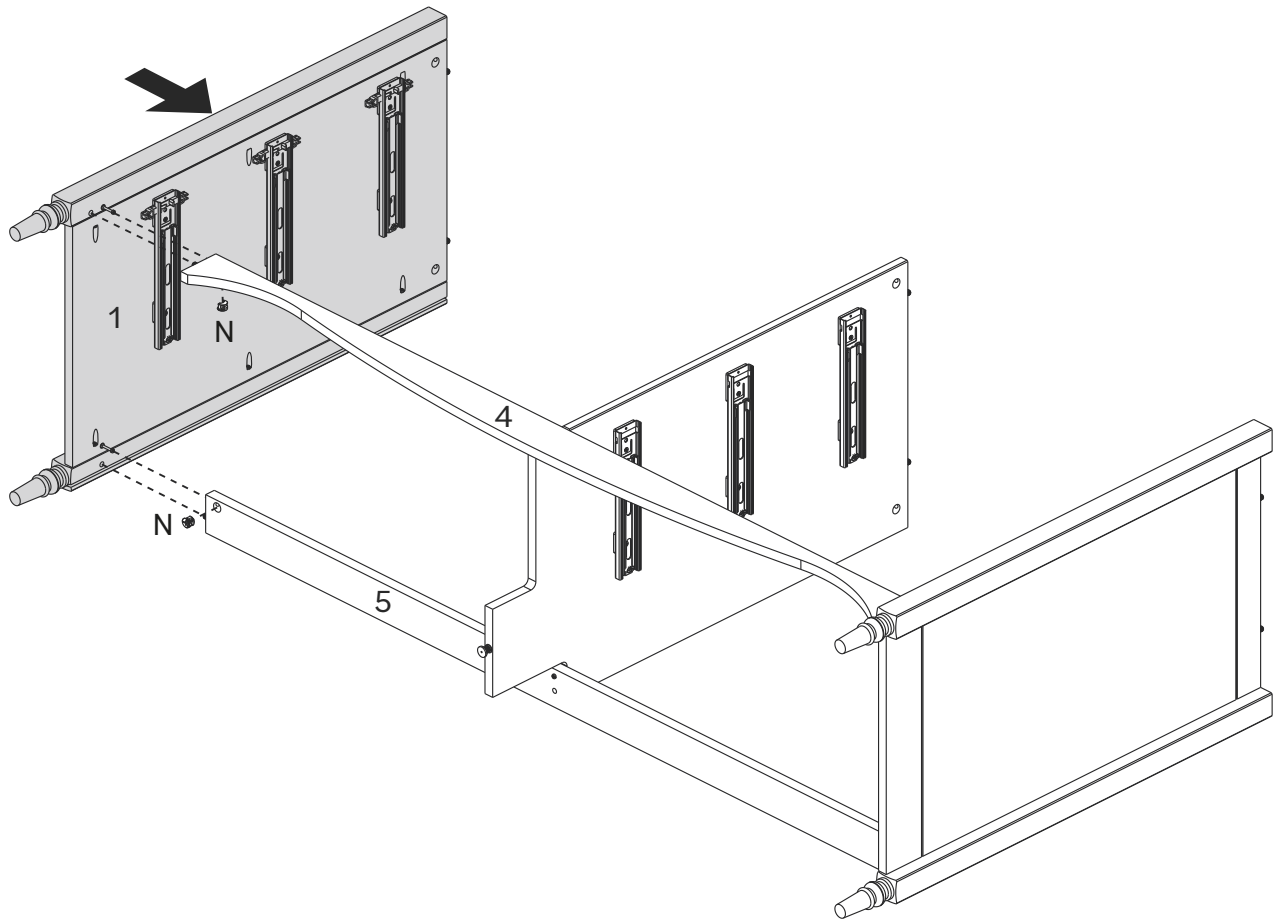

Step 18

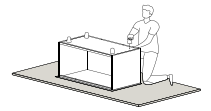

Slide Back Panel (6) on the grooves on Left Panel (1) and Right Panel (2), fitting in Back Rail (5).

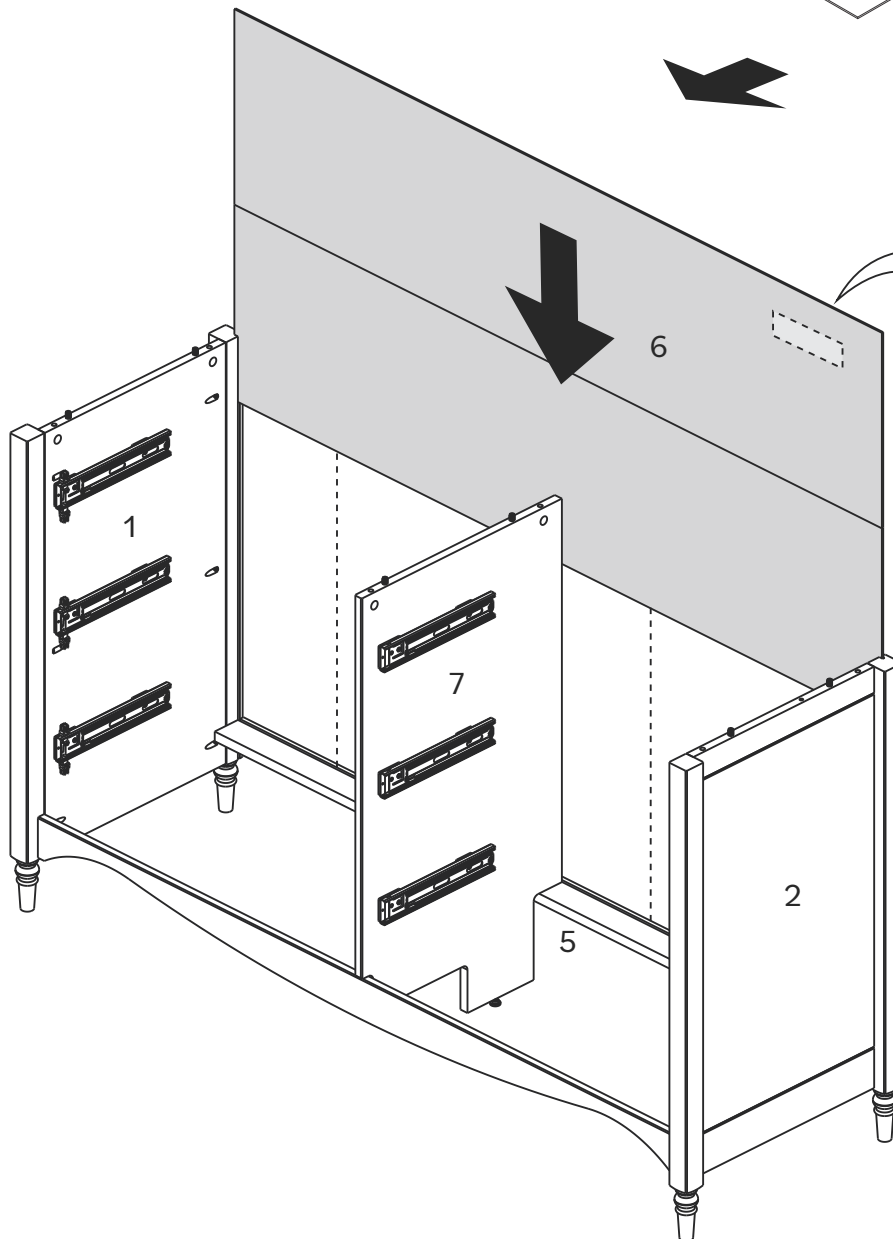
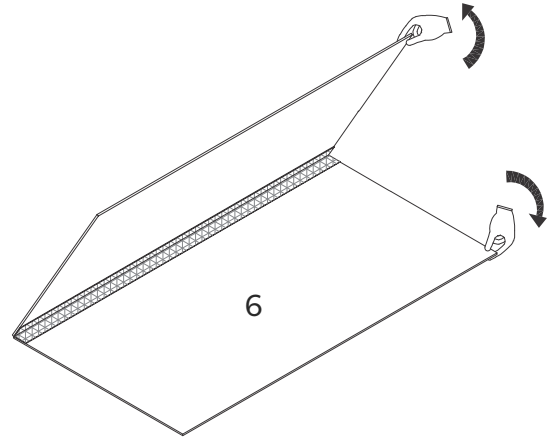
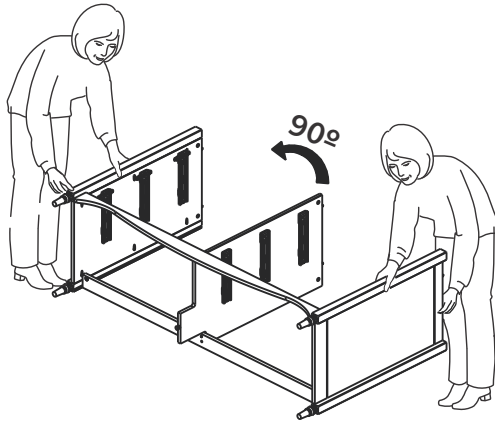

Name and address of the supplier and date of production.

Traceability label should be facing outward

Step 19

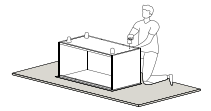

Secure Top Panel (3) to Left Panel (1), Right Panel (2) and Center Panel (7) using Cam Locks (N) and a Phillips screwdriver.

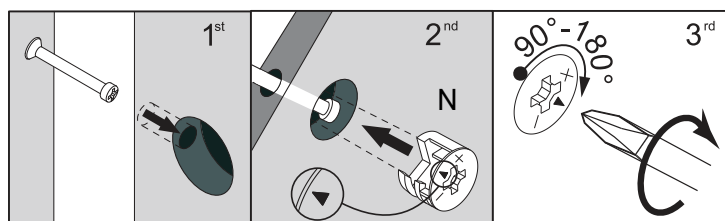
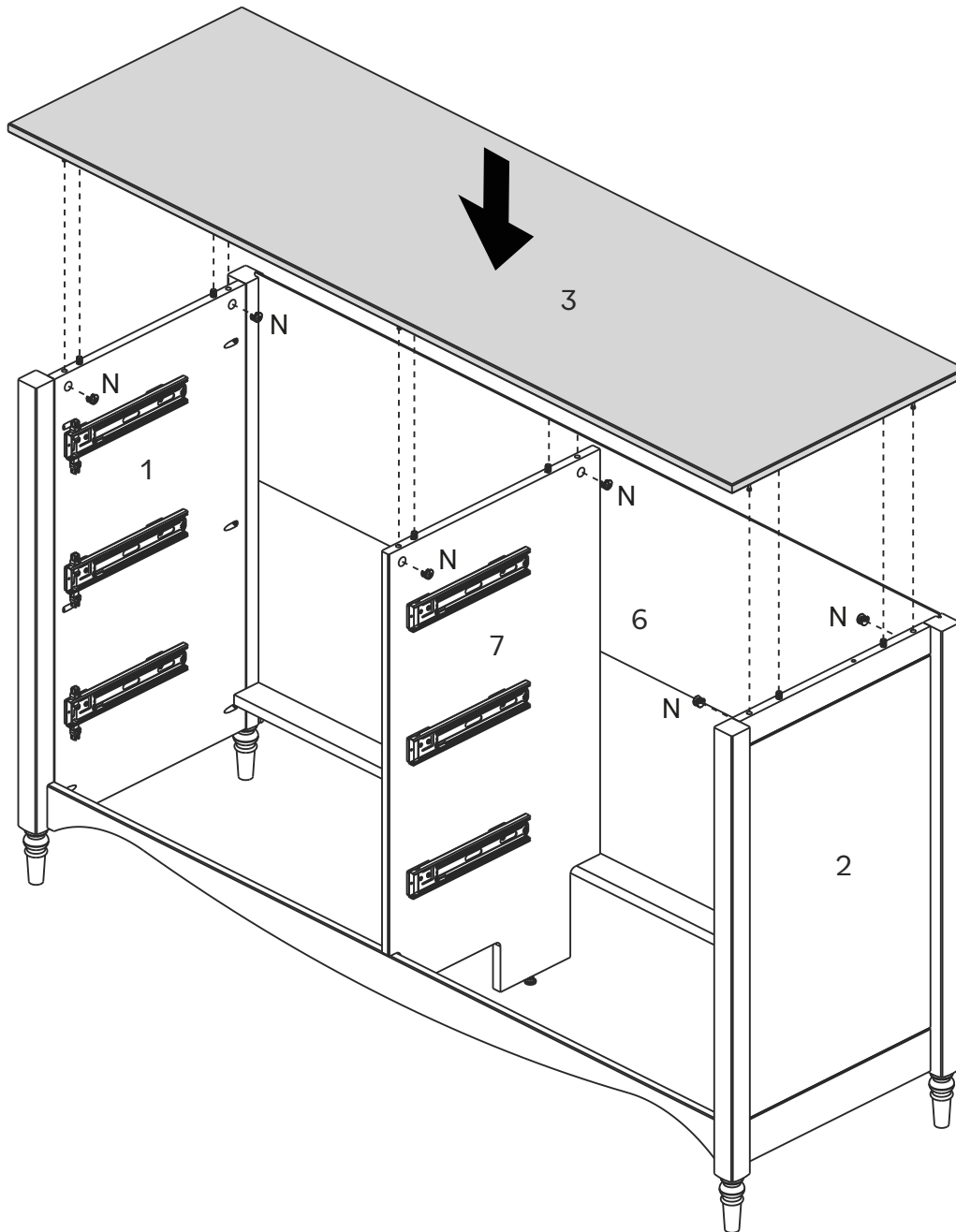

Step 20

Secure Back Panel (6) fitting Wedge (P) and screw (V) between the panel and the grooves. Use and a Phillips screwdriver.

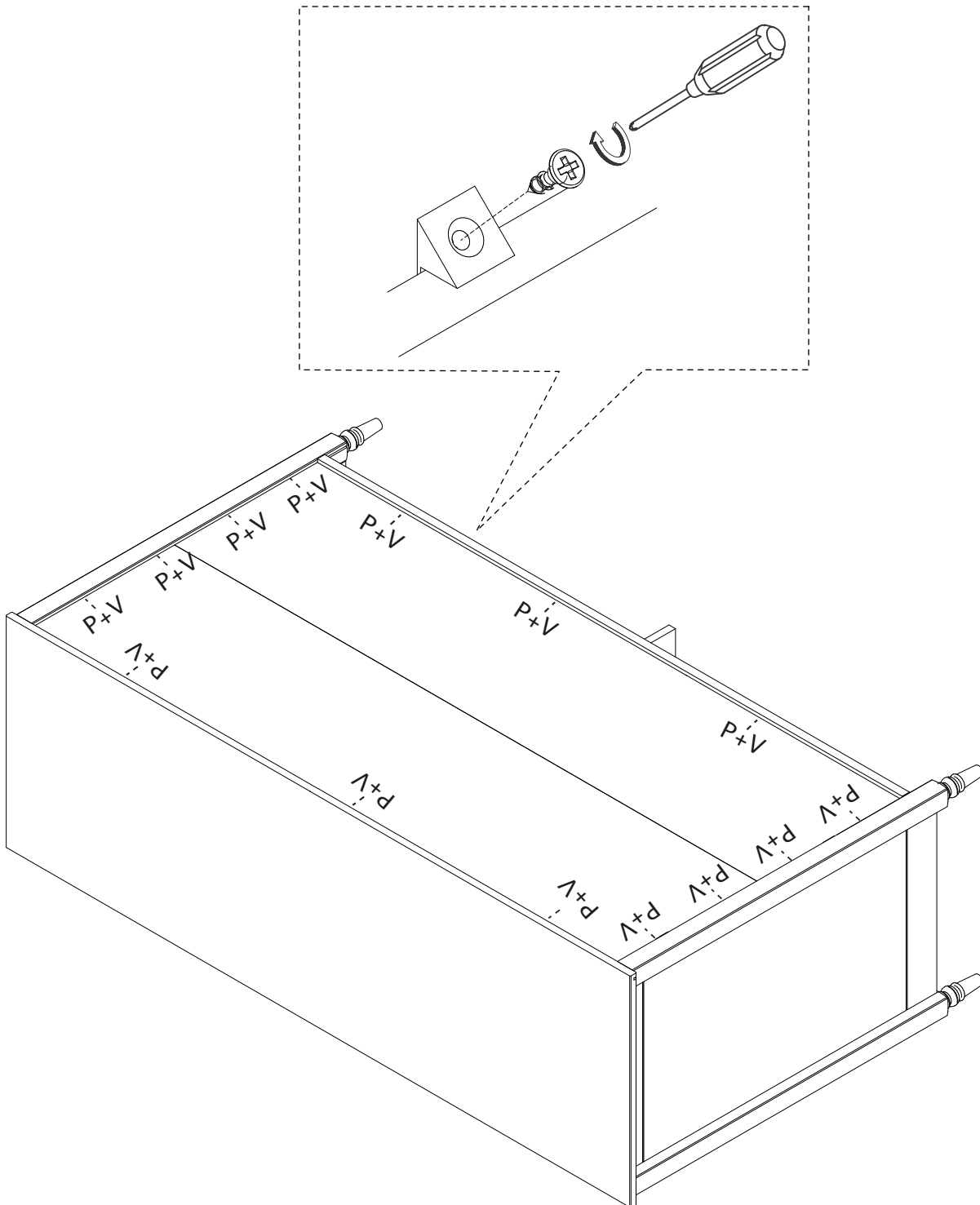

Step 21

Attach Interlock Bar (E) in the Locks (O).

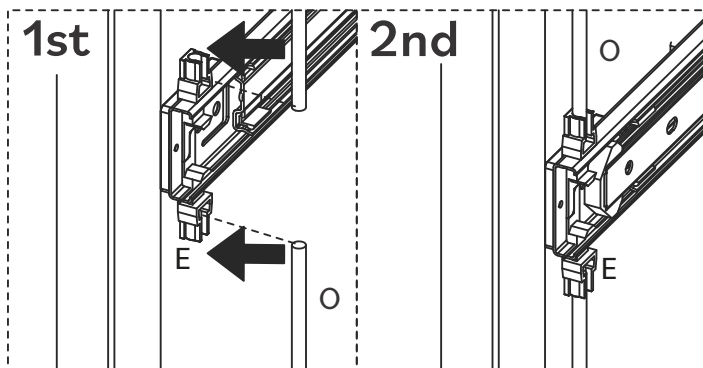
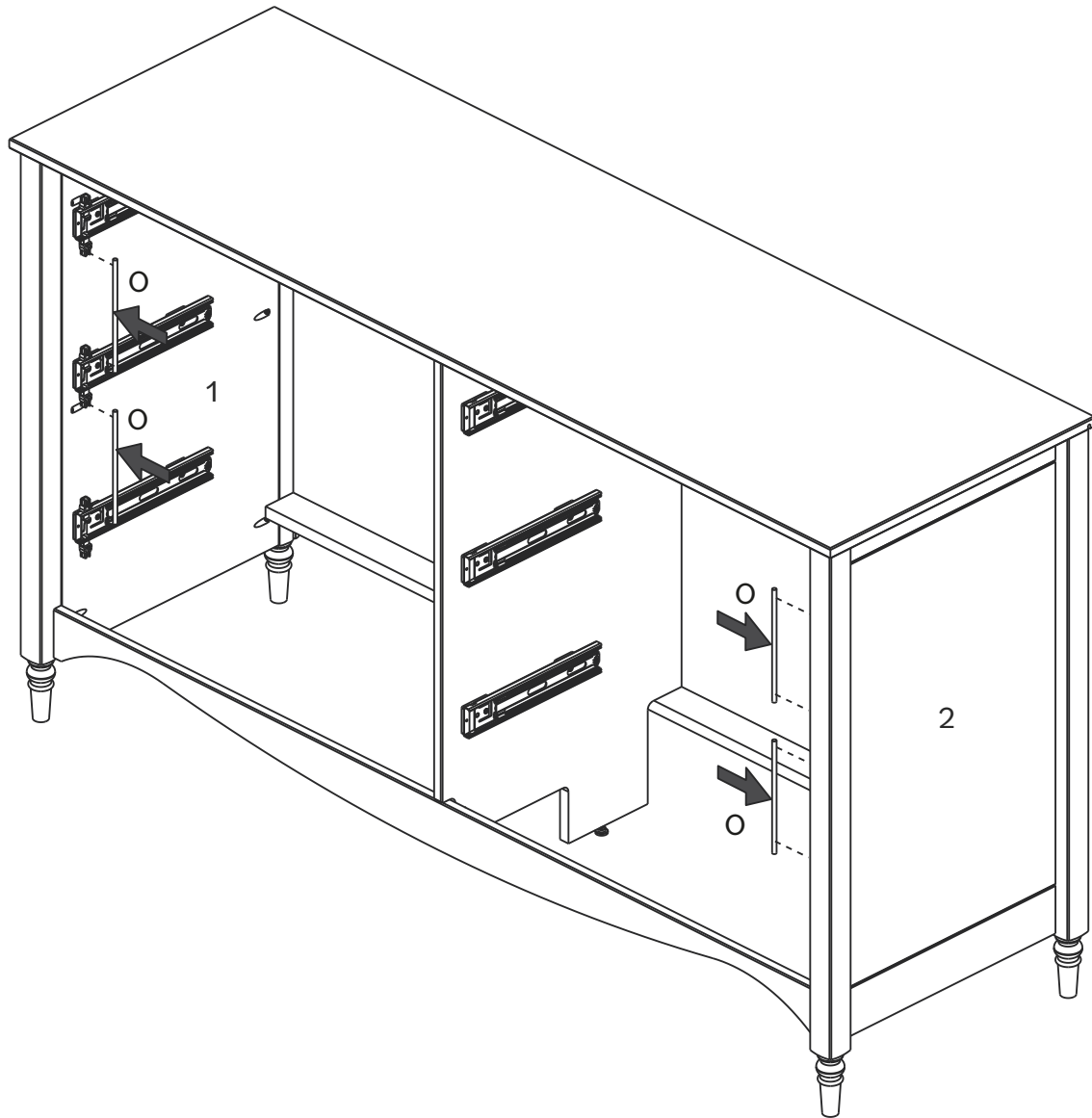

Step 23

Place the Drawers one at a time using the slider, pay attention to position them correctly aligning Outer and Inner Slider.

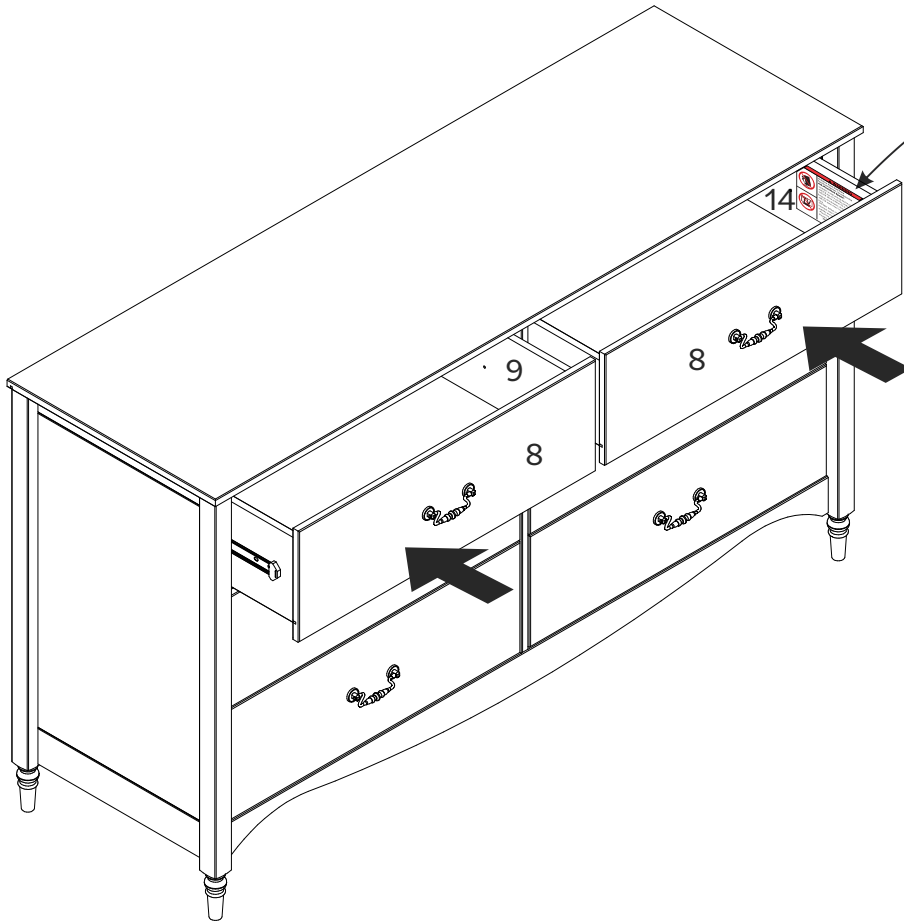

▲ WARNING	
 <p>Children have died from furniture tipover. To reduce the risk of furniture tipover:</p> <ul style="list-style-type: none"> -ALWAYS install anti tip device provided. -NEVER put a TV on this product. -NEVER allow children to stand, climb or hang on any drawers, doors, or shelves. -NEVER open more than one drawer at a time. -DO NOT defeat or remove the drawer interlock system; it is an important stability and safety system. -Place heaviest items in the lowest drawers. <p><i>This is a permanent label. Do not remove!</i></p>	<p>DO NOT remove the interlock system except for maintenance as shown. NEVER use the unit without the interlock installed following the instructions. System Specific instructions for interlock installation. Insert Interlock Lock on the sliders. After securing the sliders to the cabinet, attach the Interlock Bars to the Locks. Once this is done you can place the drawer one at a time. To remove the drawer push the locks in the sliders.</p>

The Drawer Side with **Warning Label** should be positioned as the highest drawer.

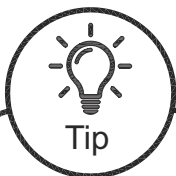
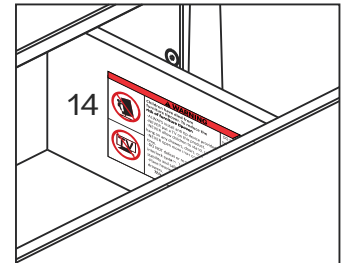

Removing the Drawer

There is a white lever in each slider, to remove the drawers pull the drawer out until you see the lever. Push one lever up and the other down, while pushing, bring the drawer out

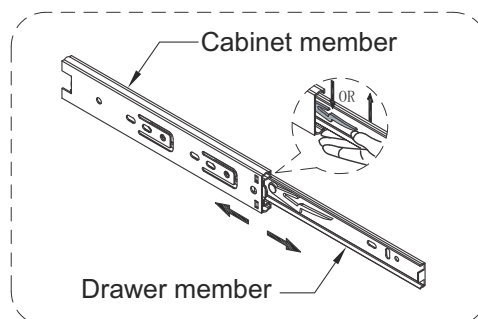

Step 24

To finish this up, attach the anti-tipping kit. Secure Wall Anchor (R) to Top Panel (3) using Washer (U), Screw (R) and a Phillips screwdriver following the details in the diagram below.

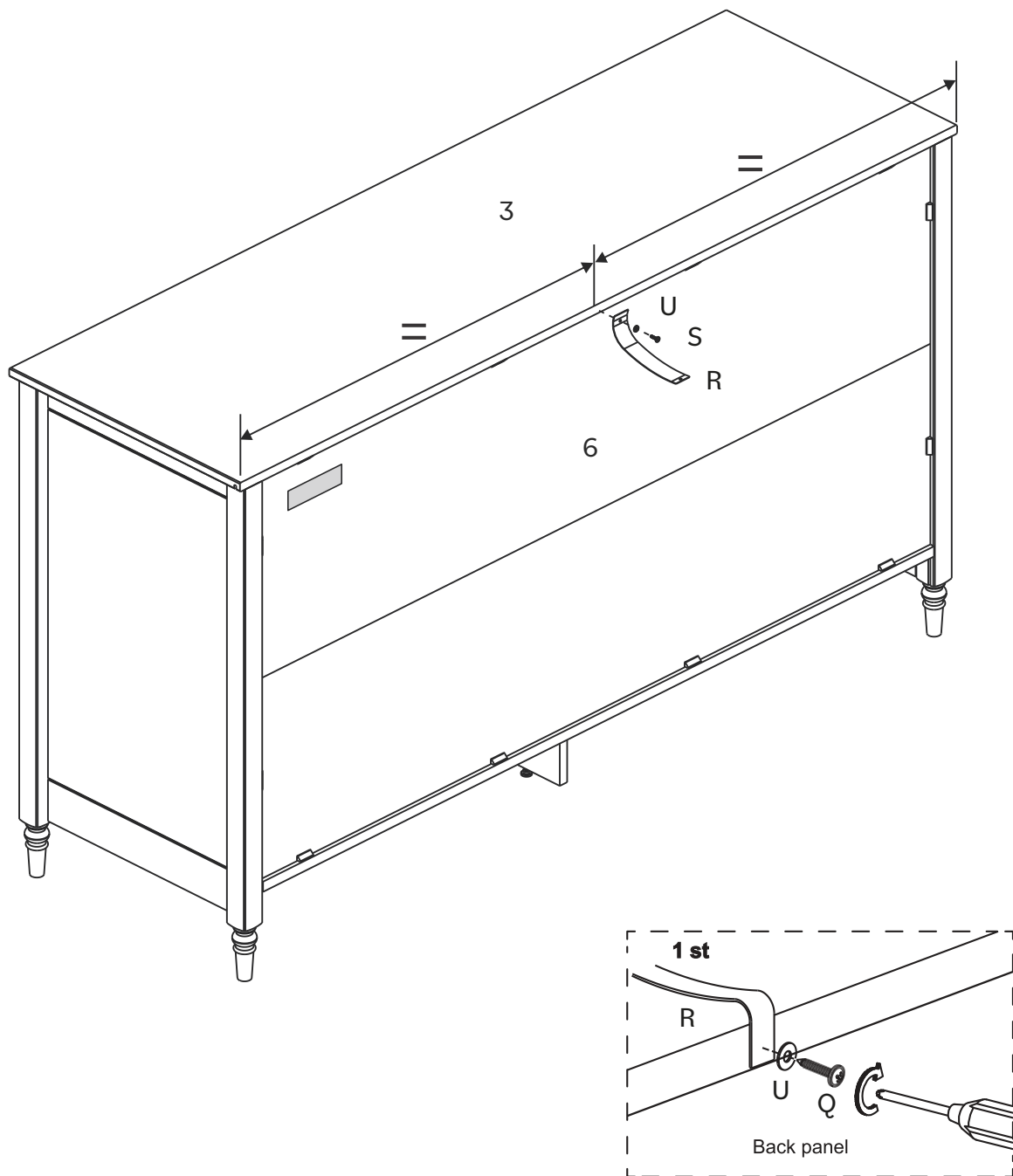

Step 25

Last step! Insert Plastic Bush (T) into the wall. Then, secure Wall Anchor (R) to the wall using Washer (U) and Screw (Q).

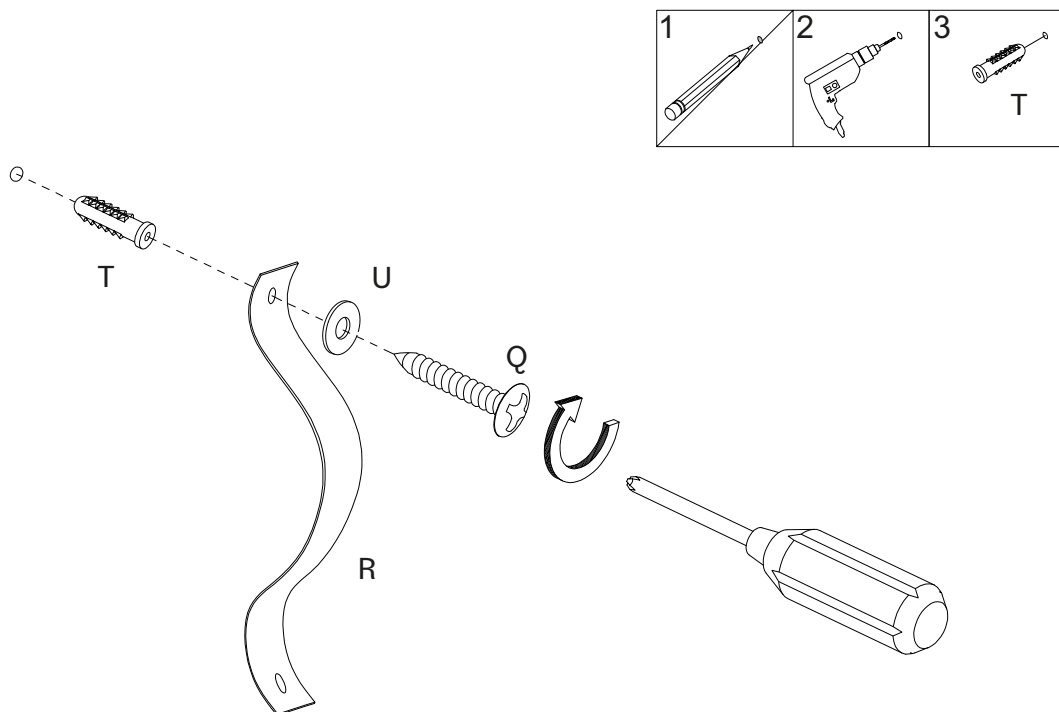

Warning

Serious or fatal injuries can occur from furniture tipping over. To prevent the furniture from tipping over we recommend that it is permanently fixed to the wall. Wall anchor and hardware are included with this product. Please make sure hardware is suitable for your walls before installing, as different wall materials may require different types of anchors.

Name and address information for the manufacturer responsible for the anti-tip hardware and date of production can be found on the label on the back of the furniture.

To Disassemble



If it is necessary to disassemble, remove the Dovetail locker (B) with a Slotted head screwdriver.

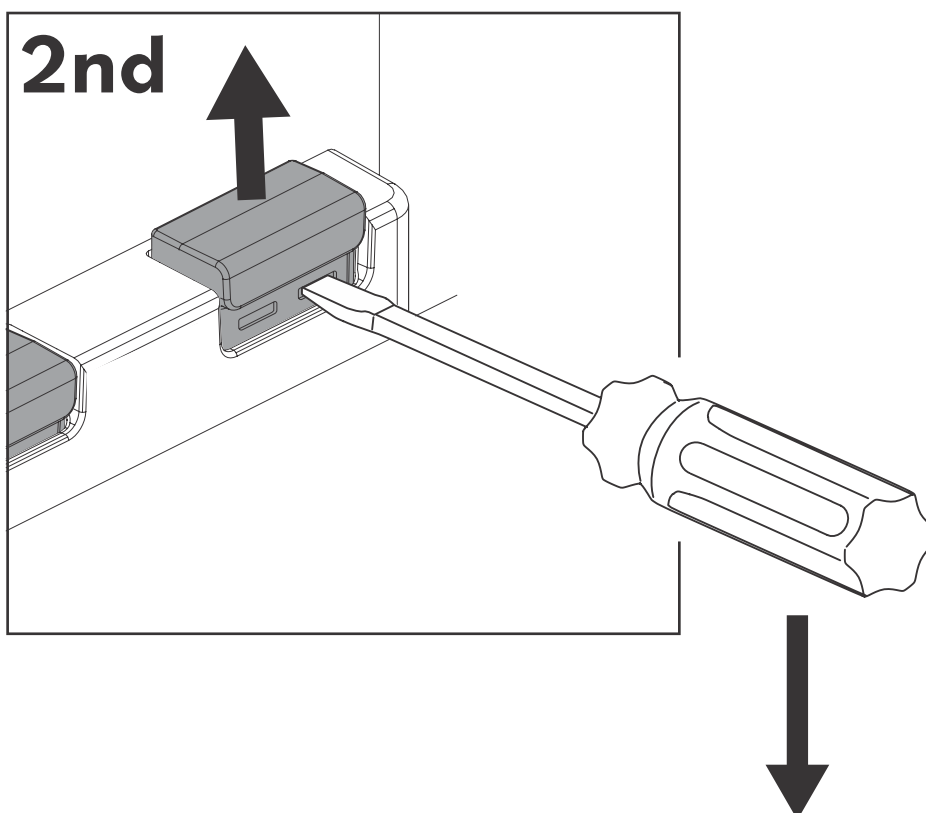
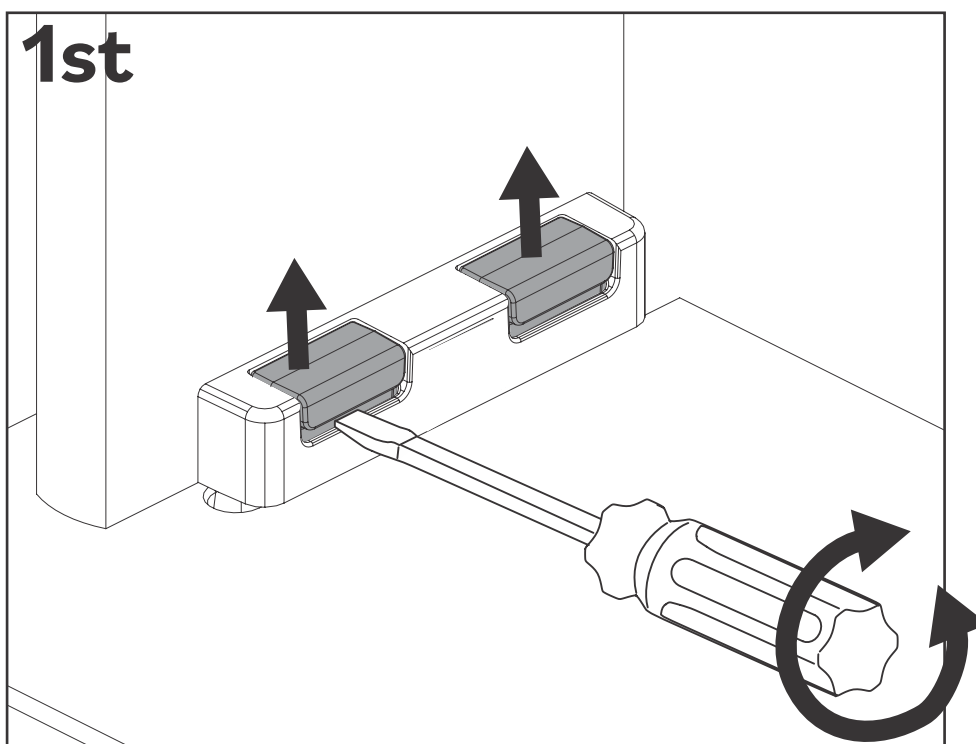

You did it! Enjoy your new Dresser!

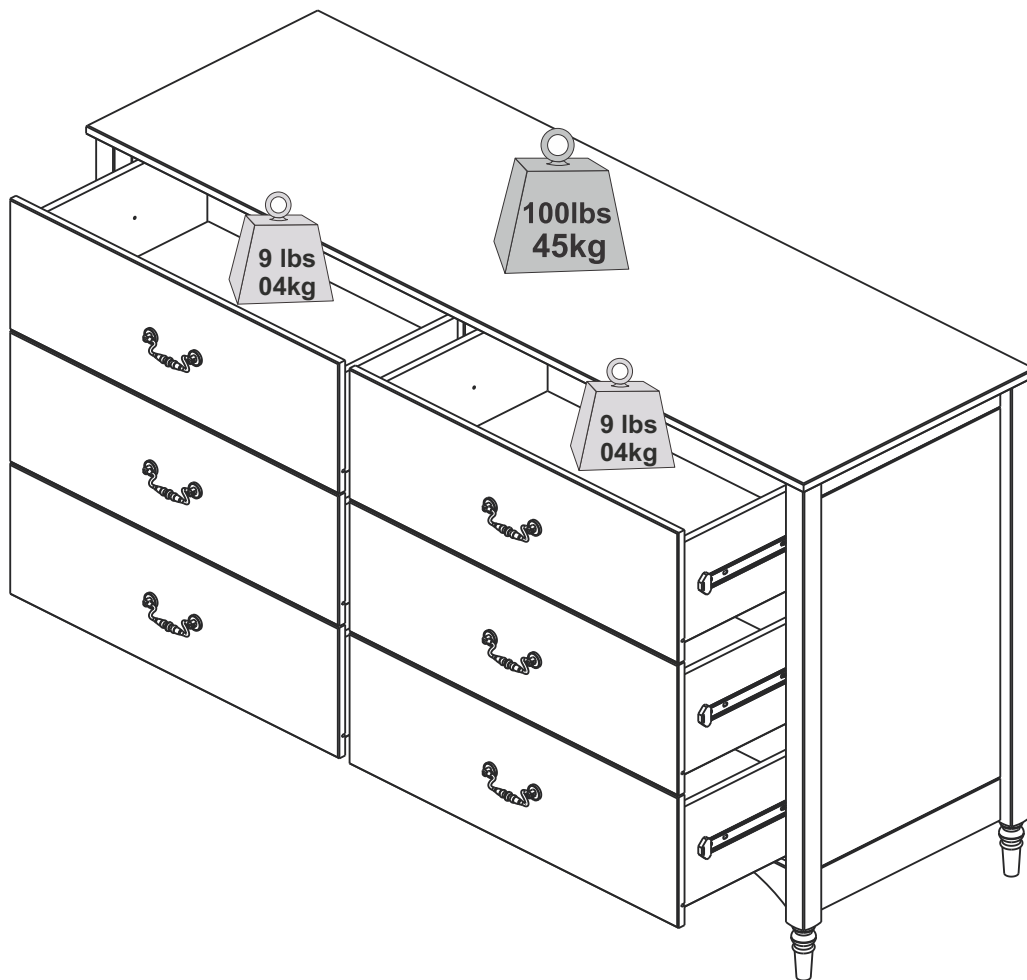

Congratulations on your new piece of furniture!

Commode à tiroirs
Cómoda con cajones

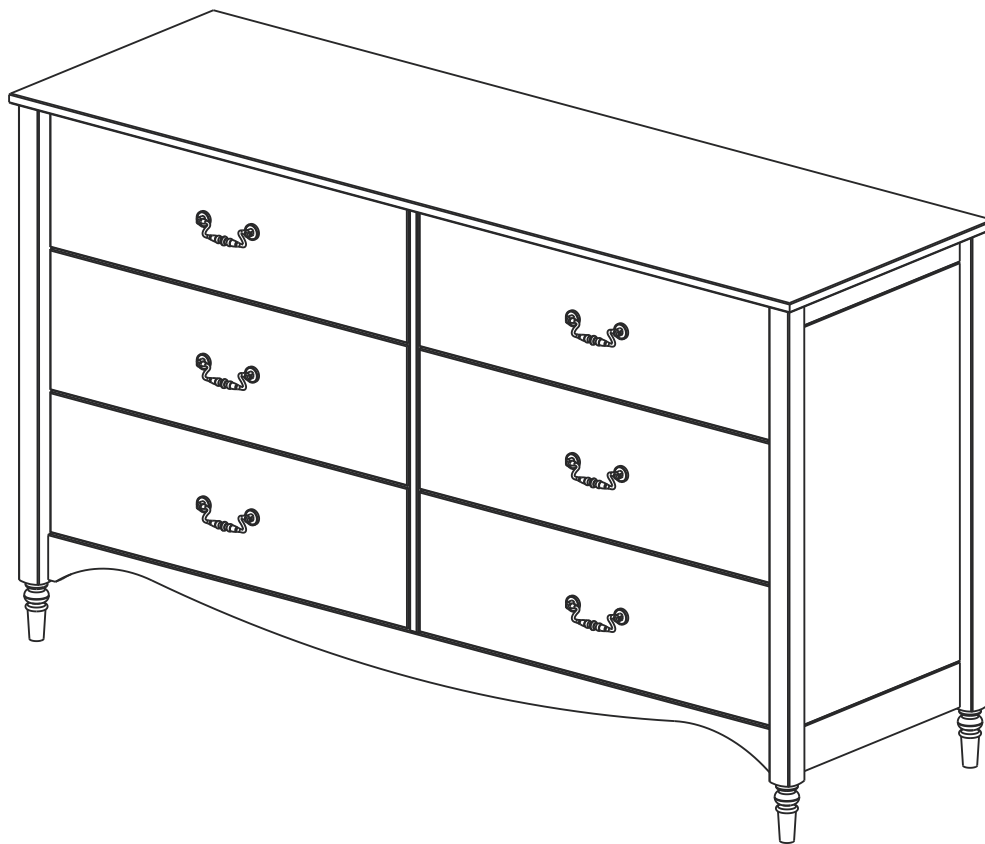

Pour usage résidentiel seulement

Sólo para uso residencial

Il est temps de commencer / Hora de empezar

Prépare un lieu de travail propre et souple pour éviter tout dommage lors de l'assemblage. Tu peux utiliser la boîte et les protections internes comme base. Vérifie également que tu disposes de toutes les pièces et parties avant de te lancer dans l'assemblage.

Prepara un lugar de trabajo limpio y blando para evitar daños durante el montaje. Puede utilizar la caja y las protecciones internas como base. Comprueba también que tiene todas las piezas y partes antes de sumergirse en el montaje.

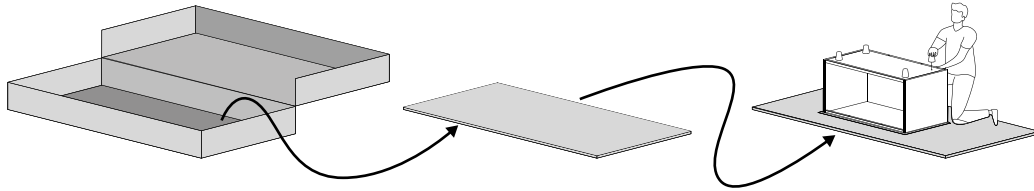

**Temps de montage
estimé**

**Tiempo estimado de
montaje**

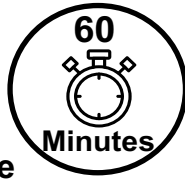

2 Personnes
2 Personas

**Personnes recommandées
pour le montage**

Fais-en un effort d'équipe !
Appelle un ami pour un assemblage
plus rapide et plus facile.

**Personas recomendadas
para el montaje**

¡Hágalo en equipo!
Llame a un amigo para que el
montaje sea más rápido y sencillo.

Outils nécessaires

Munis-toi d'un tournevis, tournevis cruciforme et marteau pour réaliser cet assemblage.

Herramientas requeridas

Tome un destornillador, destornillador Phillips y martillo para conquistar este montaje.

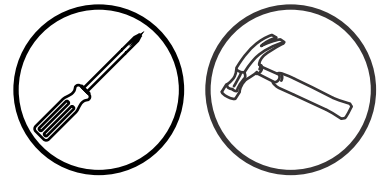

Utilise les outils électriques avec précaution

Ce meuble est réalisé en Bois Massif et Bois Composite, des matériaux souples. Si tu choisis d'utiliser des outils électriques, règle-les sur le mode le plus lent. Fais attention à toi ! Les outils électriques peuvent provoquer des fissures ou endommager les meubles, mais aussi les autres composants s'ils sont mal utilisés.

Utilice las herramientas eléctricas con cuidado.

Este mueble está fabricado con madera maciza y madera compuesta, materiales blandos. Si decide utilizar herramientas eléctricas, ajústelas al ajuste más lento. Tenga cuidado. Las herramientas eléctricas pueden causar grietas o daños en el mueble, pero también en los herrajes si se utilizan mal.

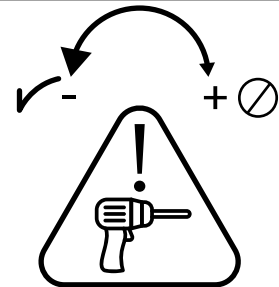

Liste de pièces / Lista de piezas

Nombre de pièces Número de pieza	Description Descripción	Quantité Cantidad
1	Panneau Droit Panel Derecho	1
2	Panneau Gauche Panel Izquierdo	1
3	Panneau Supérieur Panel Superior	1
4	Rail Avant Riel Delantero	1
5	Rail Arrière Riel Trasero	1
6	Panneau Arrière Panel Trasero	1
7	Panneau Central Panel Central	1
8	Façade du Tiroir Droit Frente del Cajón Derecho	6
9	Côté Droit du Tiroir Lado Derecho del Cajón	5
10	Côté Gauche du Tiroir Lado Izquierdo del Cajón	6
11	Arrière du Tiroir Posterior del Cajón	6
12	Fond du Tiroir Inferior del Cajón	6
14	Façade du Tiroir Droit Avertissement Frente del Cajón Derecho Advertencia	1





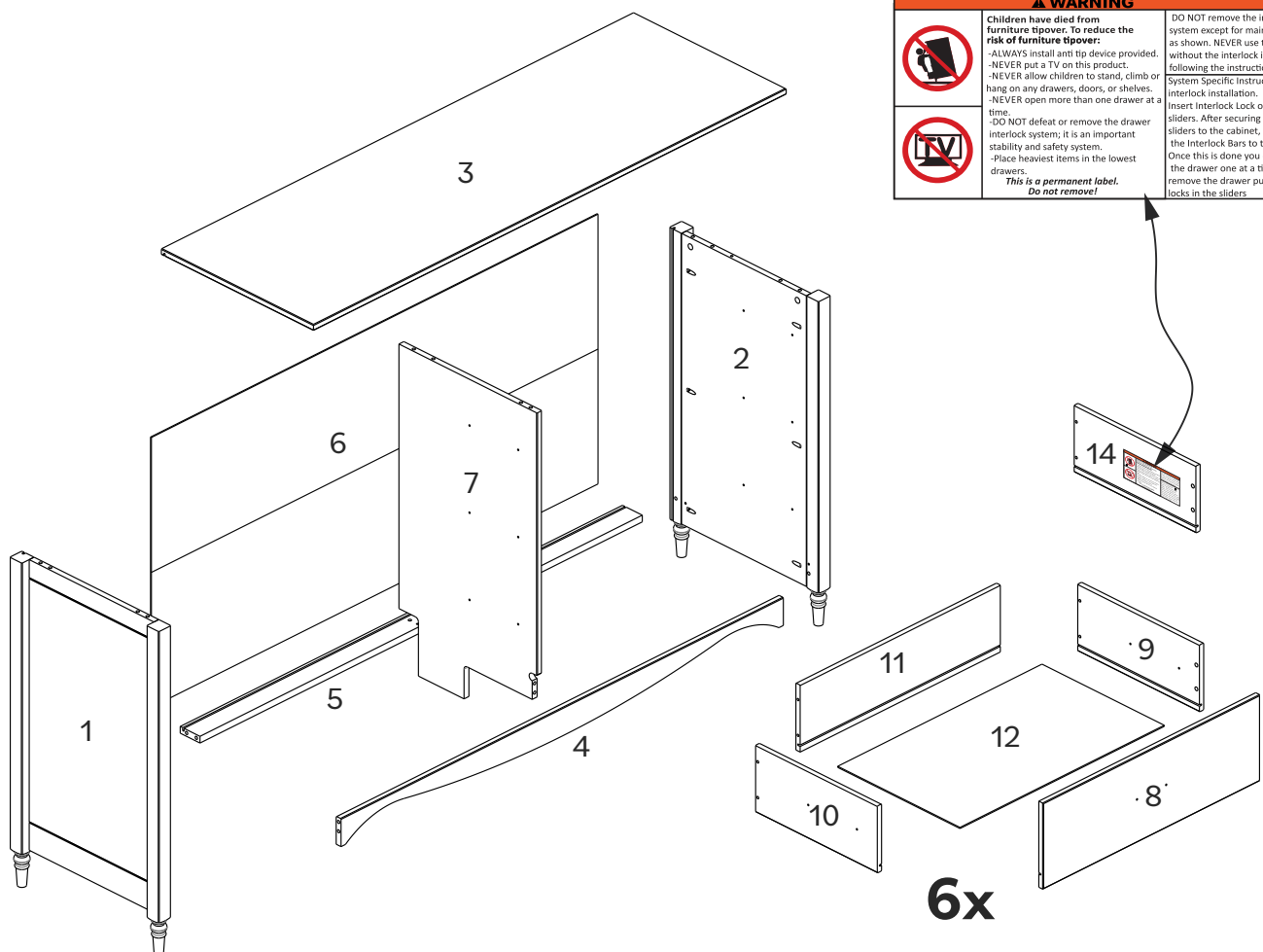









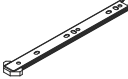

Le tiroir avec
l'ÉTIQUETTE
D'AVERTISSEMENT
doit être placé
comme tiroir le plus
haut.

El cajón con
ETIQUETA DE
ADVERTENCIA, debe
colocarse como el
cajón más alto.

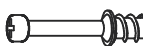

⚠ WARNING	
	<p>Children have died from furniture tipover. To reduce the risk of furniture tipover:</p> <ul style="list-style-type: none"> -ALWAYS install anti tip device provided. -NEVER put a TV on this product. -NEVER allow children to stand, climb or hang on any drawers, doors, or shelves. -NEVER open more than one drawer at a time. -DO NOT defeat or remove the drawer interlock system. It is an important stability and safety system. -Place heaviest items in the lowest drawers. <p><i>This is a permanent label. Do not remove!</i></p>
	<p>DO NOT remove the interlock system except for maintenance as shown. NEVER use the unit without the interlock installed following the instructions.</p> <p>System Specific instructions for interlock installation.</p> <p>Insert Interlock Lock on the sliders. After securing the sliders to the cabinet, attach the Interlock Bars to the Locks. Once this is done you can place the drawer one at a time. To remove the drawer push the locks in the sliders.</p>

Liste de composants / Lista de hardware

Partie Parte	Taille Tamaño	Nom Nombre	Quantité Cantidad
A		Dovetail Dovetail	12
B		Dovetail Lock Dovetail Lock	24
C		Vis Plastique Tornillo Plastico	24
D	 6x12mm	Vis Tornillo	24
E		Interlock Lock Interlock Lock	12
F	 6x14mm	Vis Tornillo	24
G1	 250mm	Glissière Extérieur Corredera Exterior	12
G2	 250mm	Glissière Intérieur Corredera Interior	12
H		Poignée Manija	6
I	 M4x19mm	Vis Tornillo	12
J	 8x30mm	Cheville Espiga	12
K		Douille Plastique Casquillo Plastico	1
L		Pied Replâbe Pata Ajustable	1
M	 6x31mm	Goujon Conector	11
N	 15x11mm	Boitier Traba	11
O		Interlock Bar Interlock Bar	4
P		Wedge Wedge	14

Les quantités de composants indiquées ci-dessus sont nécessaires pour un assemblage correct.

Des pièces supplémentaires peuvent être incluses.

Las cantidades de tornillería indicadas anteriormente son necesarias para un montaje correcto.

Se pueden incluir piezas de ferretería adicionales.

Hardware List

Part	Size	Name	Quantity
Q 	4x40mm	Rubán Cinta	2
R 		Vis Tornillo	1
S 	4x16mm	Douille Casquillo	1
T 	6x35mm	Rondelle Arandela	1
U 		Vis Tornillo	2
V 	3,5X14mm	Screw	14

*The hardware quantities listed above are required for proper assembly.
Extra hardware pieces may be included.*

Introduction pour un assemblage facile du système de tiroirs

Dis adieu au tracas de l'assemblage !

Nous comprenons que l'assemblage des tiroirs peut être la partie la plus longue et la plus fastidieuse de l'assemblage de tes nouveaux meubles. C'est pourquoi nous avons développé le système de tiroirs d'assemblage facile - pour rendre le processus plus facile !

Dovetail Verrouillage Traba

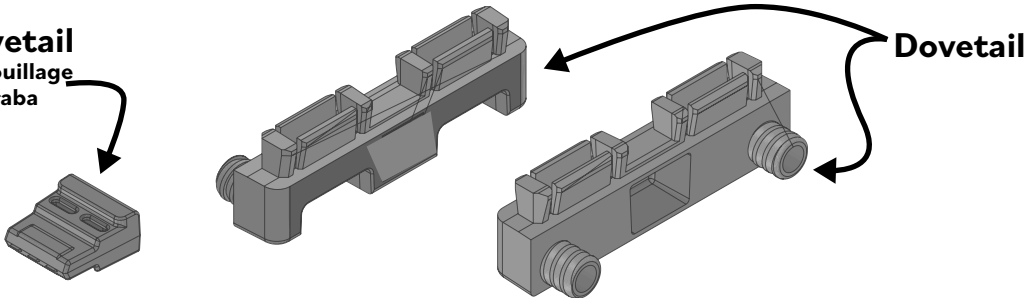

Pourquoi tu vas adorer notre système de tiroirs d'assemblage facile :

Rapide et facile : notre nouveau système de tiroir réduit considérablement le temps d'assemblage. Fais-le vite !

Effort minimal requis : Conçu pour être extrêmement simple, tu n'auras besoin que de peu ou pas d'outils pour effectuer le travail.

Construit pour durer : Solide et résistant, notre système garantit que tes tiroirs restent solides et fiables.

Préparons le scénario pour l'assemblage :

Step 1: Prépare-toi -

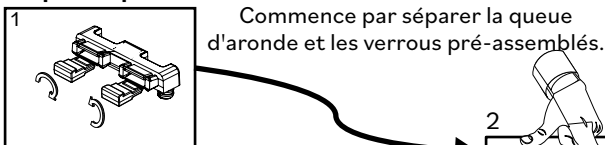

Commence par séparer la queue d'aronde et les verrous pré-assemblés.

Step 2: Jonction -
Combine la queue d'aronde avec les côtés du tiroir comme indiqué sur l'illustration.

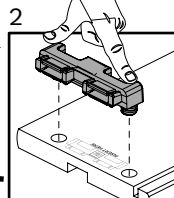

Step 3: Glisse dans la rainure -
Fais glisser la queue d'aronde dans les rainures de la face avant des tiroirs.

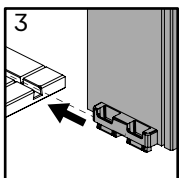

Step 4: Verrouillage -
Après avoir installé le fond du tiroir, verrouille la queue d'aronde à l'aide des loquets à queue d'aronde

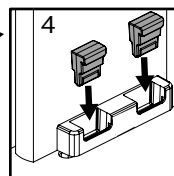

Attention : Lors des prochaines étapes, tu trouveras plus de détails pour t'aider durant l'assemblage.

Introducción al Sistema de Fácil Montaje de Cajones

¡Despídete de las complicaciones del montaje!

Entendemos que ensamblar cajones puede ser la parte más lenta y tediosa de ensamblar tus muebles nuevos. Es por eso que desarrollamos el Sistema de Cajones de Montaje Fácil, ¡para facilitar el proceso!

Por qué te encantará nuestro sistema de cajones fácil de montar:

Rápido y fácil : nuestros nuevos herrajes para cajones reducen significativamente el tiempo de montaje. ¡Hazlo rápido!

Mínimo esfuerzo requerido : Diseñado para ser muy simple, necesitarás pocas o ninguna herramienta para hacer el trabajo.

Fabricado para durar : Fuerte y resistente, nuestro sistema garantiza que tus cajones permanezcan sólidos y confiables.

Preparamos el espacio para el montaje:

Step 1: ¡Prepárate! -



Comienza separando la cola de milano y las trabas premontadas.

Step 2: Unión -
Combina la cola de milano con los lados del cajón, como se muestra en la ilustración.

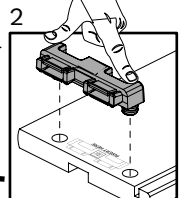

Step 3: Desliza en la ranura -
Desliza la cola de milano en las ranuras de los frentes de los cajones.

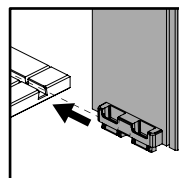

Step 4: Traba -
Después de colocar la parte inferior del cajón, bloquea la cola de milano usando las trabas de cola de milano.

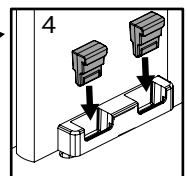

Atención : En los próximos pasos, hay más detalles para ayudarte con el montaje.

Étape / Paso 1

(FR)

Préparez les Dovetails (A) en retirant les Dovetail Locks (B) des Dovetails (A).

(ES)

Prepare los Dovetails (A) quitando los Dovetail Locks (B) de los Dovetails (A).

1st

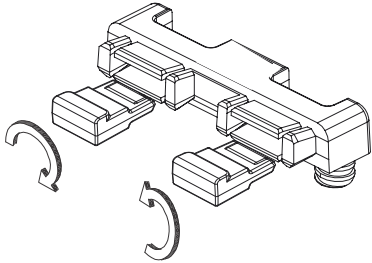

2nd

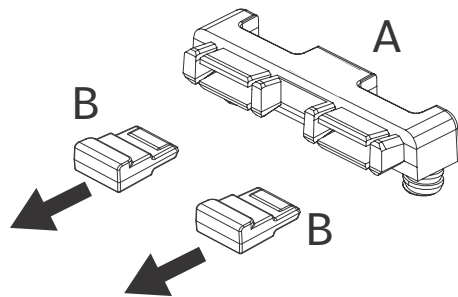

Étape / Paso 2

(FR)

Insérez les Dovetails (A) en place sur les Côtés Droits des Tiroirs (9 et 14) et les Côtés Gauches des Tiroirs (10). Appuyez sur les Dovetails jusqu'à ce qu'ils soient complètement fixés. Utilisez un marteau si nécessaire.

(ES)

Coloque los Dovetails (A) en los Laterales Derechos de los Cajones (9 y 14) y en los Laterales Izquierdos de los Cajones (10). Presione los Dovetails hasta que estén completamente fijados. Use un martillo si es necesario.

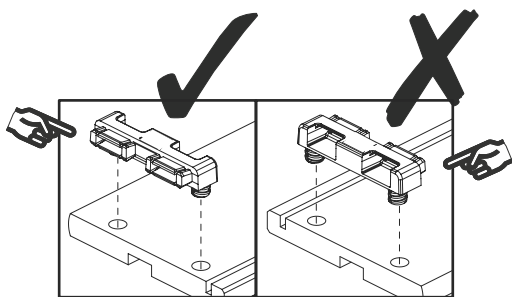

Appuyez sur la pièce jusqu'à ce qu'elle soit complètement fixée.

Presione la pieza hasta que esté completamente fijada.

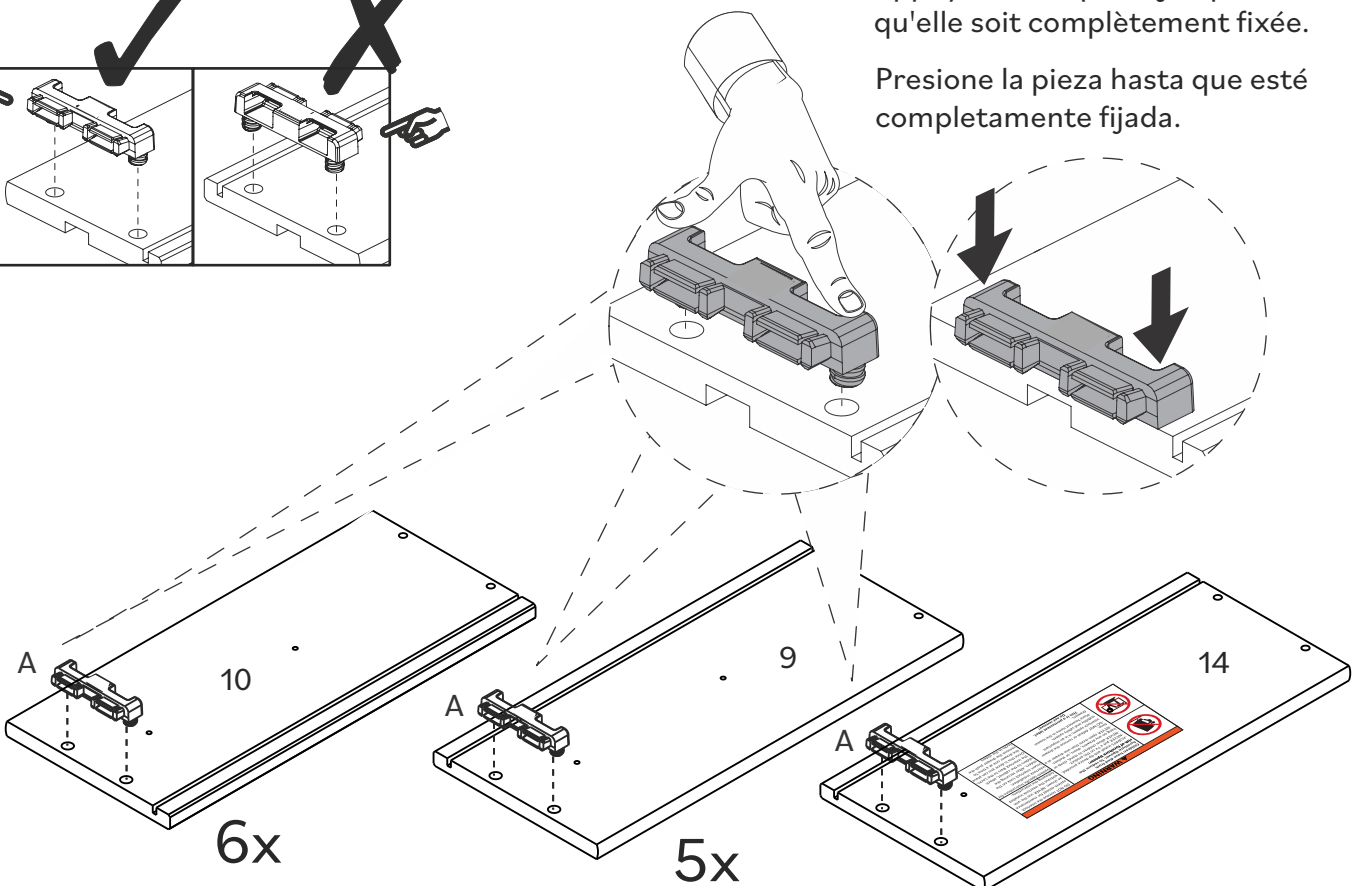

Étape / Paso 3

(FR)

Faites glisser le Dovetail (A) du Panneau Droit du tiroir (9/14) et du Panneau Gauche du tiroir (10) dans les rainures de la Façade du tiroir (8).

(ES)

Deslice el Dovetail (A) del Panel Derecho del Cajón (9/14) y del Panel Izquierdo del Cajón (10) en las ranuras del Frente del Cajón (8).

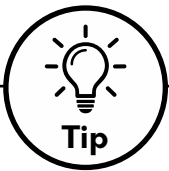
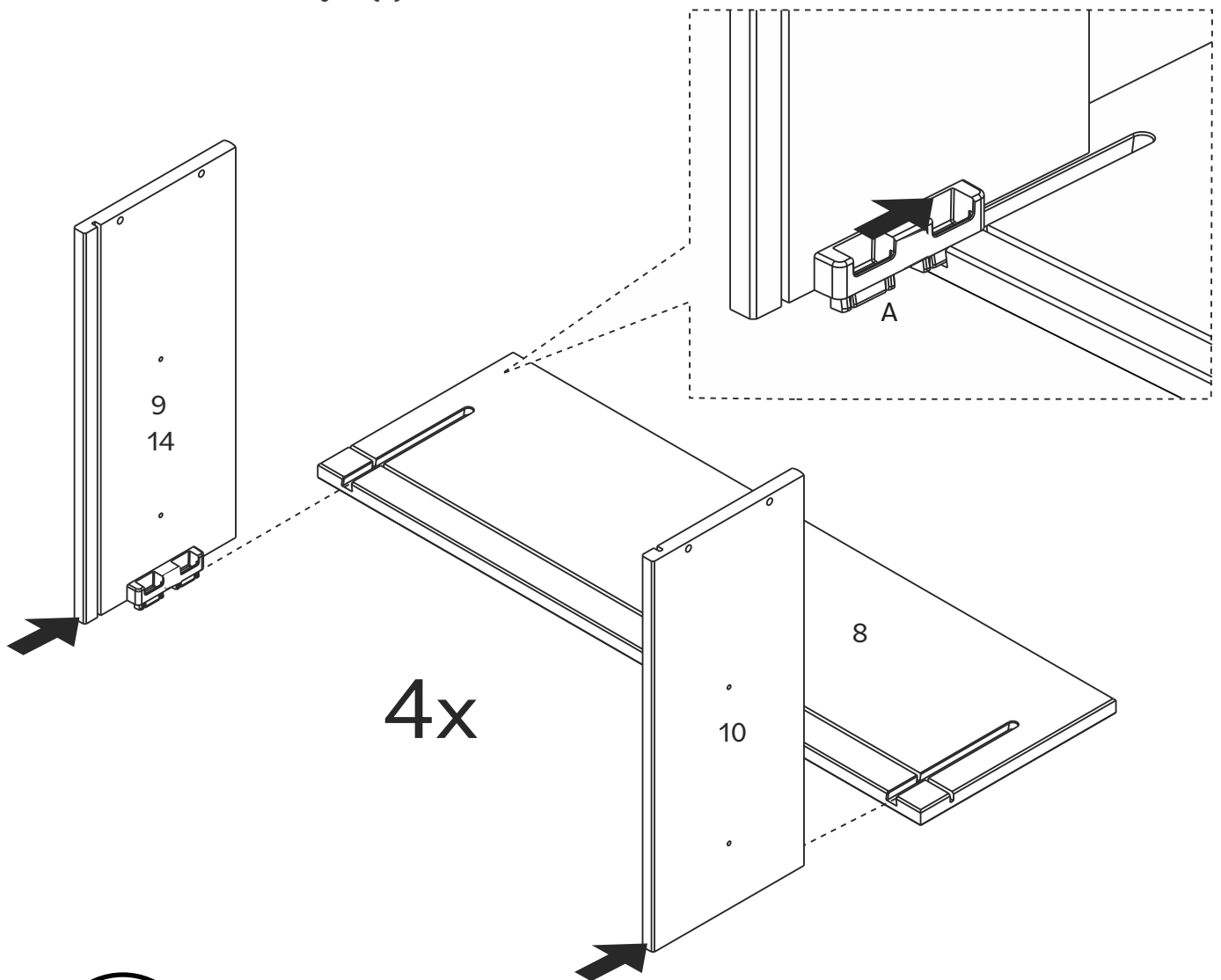

Tip

Pour que ton produit conserve son meilleur aspect et sans rayures, essaie de le monter sur une surface souple telle qu'un tapis ou une couverture. Cela permet d'éviter les rayures accidentelles et de garder tes meubles en bon état !

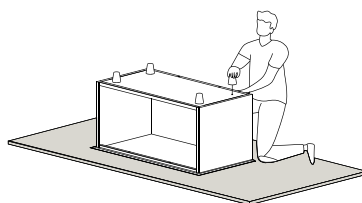

Para mantener su producto con el mejor aspecto y sin arañazos, pruebe a montarlo sobre una superficie blanda, como una alfombra o una manta. Así evitará arañazos accidentales y mantendrá sus muebles en perfecto estado.

Étape / Paso 4



(FR)

Faites glisser le Fond du tiroir (12) entre les rainures du Côté Droit du tiroir (9 et 14) et du Côté Gauche du tiroir (10) en l'insérant dans la Façade du tiroir (8).

(ES)

Deslice el Fondo del Cajón (12) entre las ranuras del Lateral Derecho del Cajón (9 y 14) y el Lateral Izquierdo del Cajón (10) encajándolo en el Frente del Cajón (8).

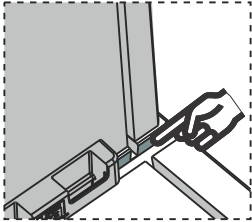

Alignez les rainures sur les côtés et le devant du tiroir pour recevoir le fond du tiroir

Alinee las ranuras en los lados y el frente del cajón para recibir la parte inferior del cajón.

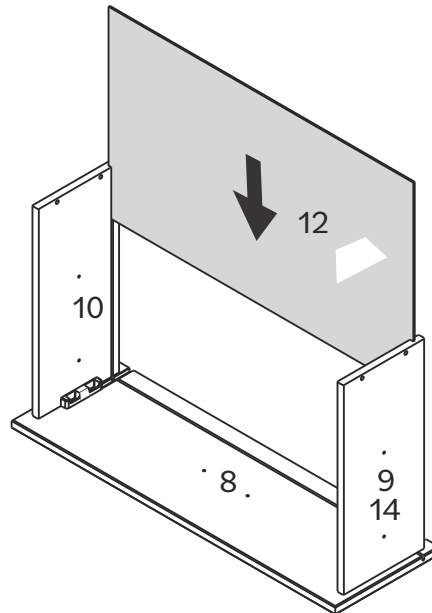

6x

Étape / Paso 5

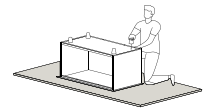

(FR)

Pour sécuriser les côtés du tiroir, insérez les Dovetail Locks (B) dans les Dovetails (A). Utilisez un marteau si nécessaire.

(ES)

Para asegurar los laterales del cajón, inserte los Dovetail Locks (B) en los Dovetails (A). Use un martillo si es necesario.

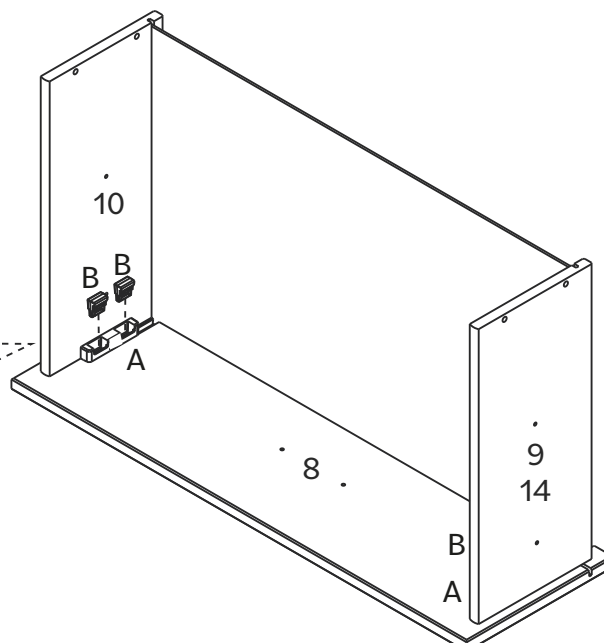
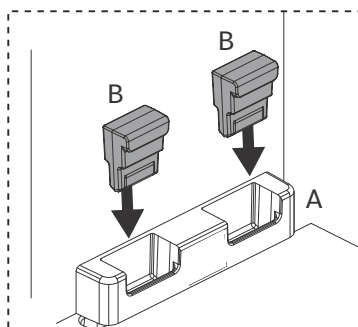

6x

Une fois cette étape terminée, votre produit devrait ressembler à ceci:

Una vez completado este paso, su producto debería verse así:

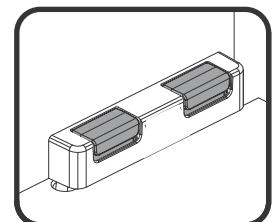

Étape / Paso 6



(FR)

Fixez le Fond du tiroir (12) à l'Arrière du tiroir (11) et sécurisez à l'aide de la Vis en Plastique (C), vous pouvez l'insérer à la main ou avec un marteau

(ES)

Fije el Fondo del Cajón (12) a la Parte Trasera del Cajón (11) y asegure con el Tornillo de Plástico (C), puede insertarlo a mano o con un martillo.

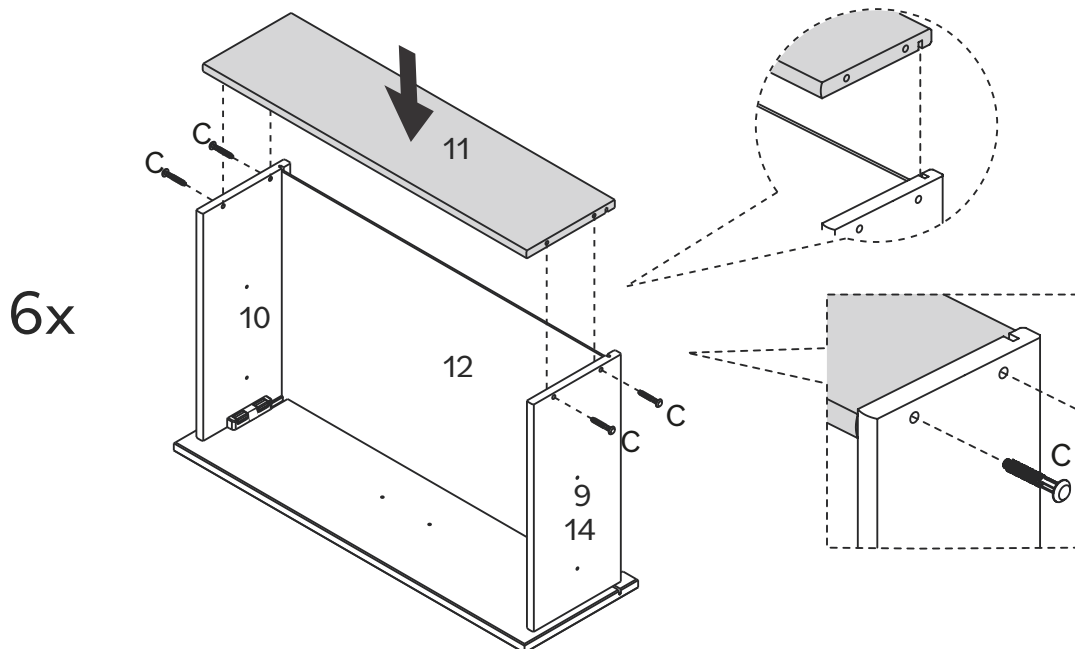

Étape / Paso 7

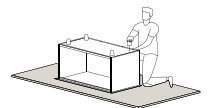

(FR)

Fixez les Glissières Intérieures (G2) aux Côtés Droits du tiroir (9 et 14) et aux Côtés Gauches du tiroir (10) en utilisant les Vis (D) et un tournevis cruciforme.

(ES)

Fije las Correderas Interiores (G2) a los Laterales Derechos del Cajón (9 y 14) y a los Laterales Izquierdos del Cajón (10) utilizando los Tornillos (D) y un destornillador Phillips.

Séparez les pièces G1 et G2 en appuyant sur le verrou.

Separe las piezas G1 y G2 presionando el seguro.

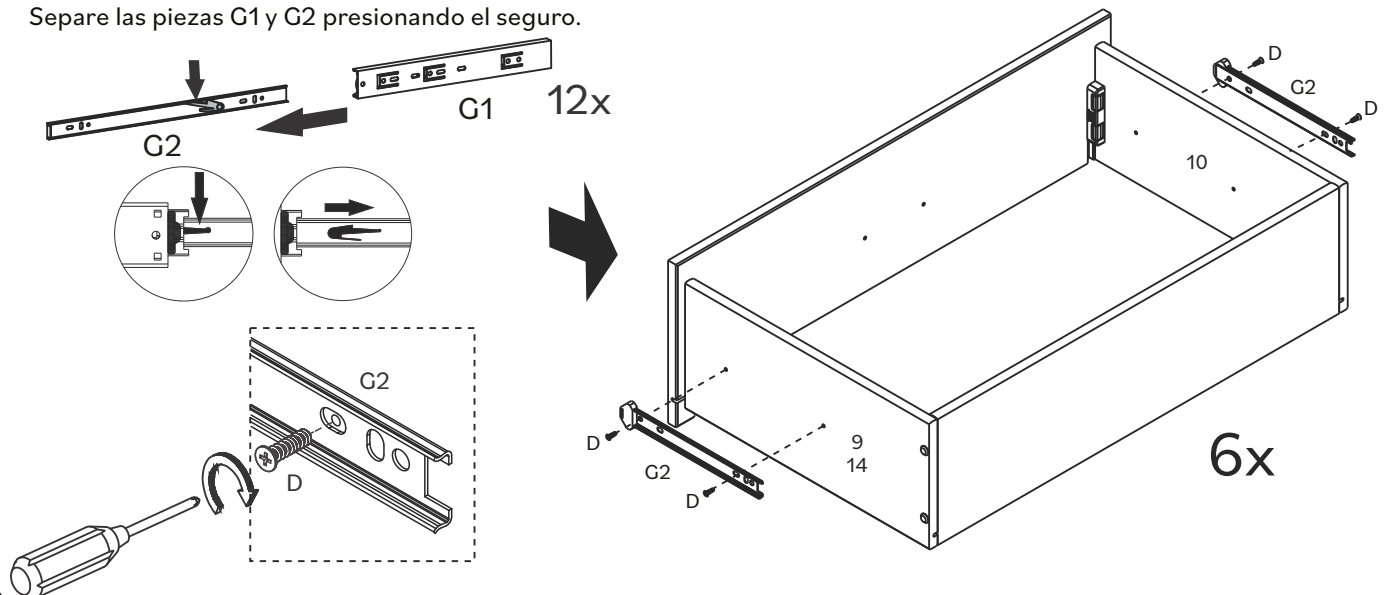

Étape / Paso 8



(FR)

Utilisez les Vis (I) et un tournevis cruciforme pour fixer les Poignées (H) aux Façades des Tiroirs (8).

(ES)

Utilice los Tornillos (I) y un destornillador Phillips para fijar las Manijas (H) a los Frontes de los Cajones (8).

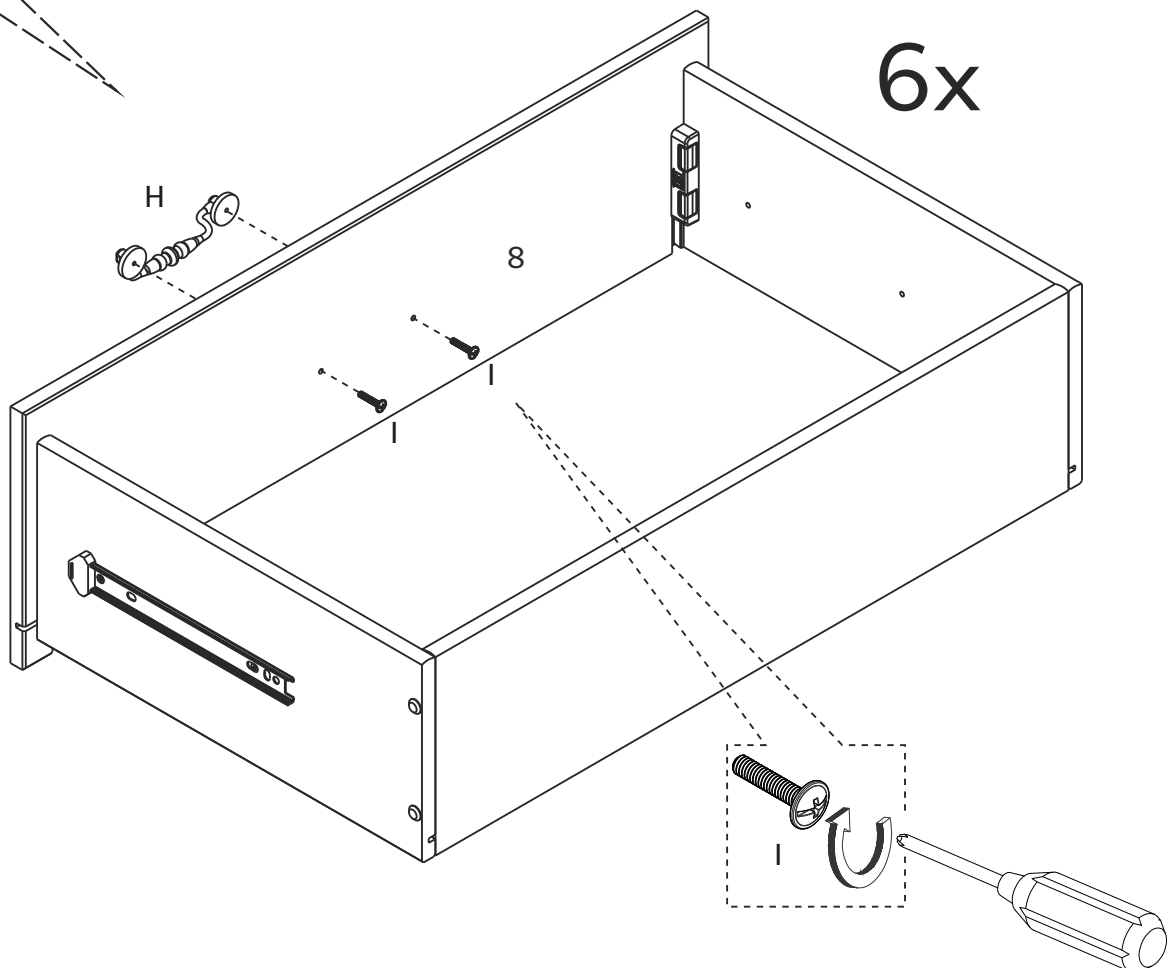
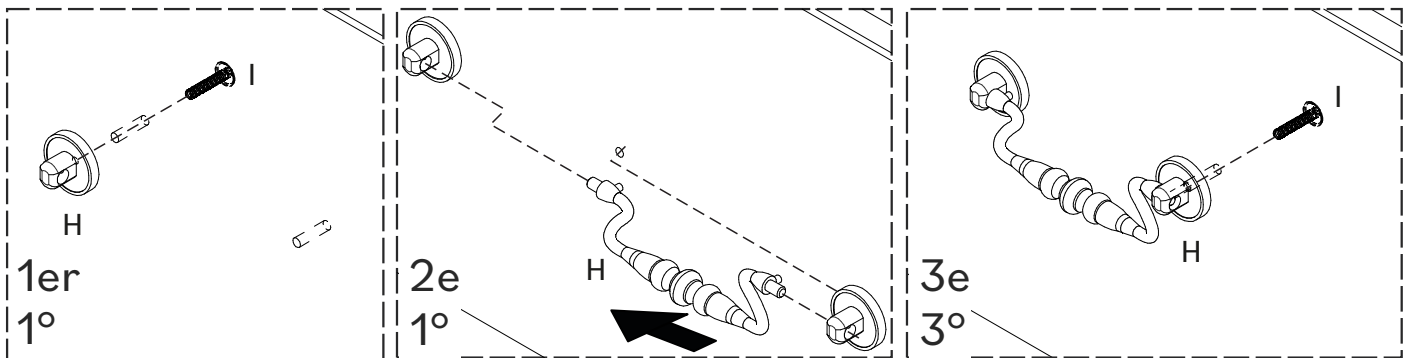
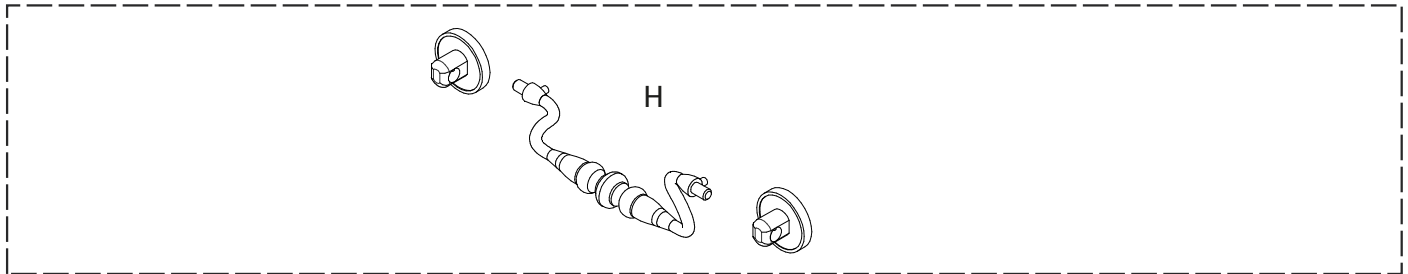

Étape / Paso 9



(FR)

Insérez les Chevilles (J) dans le Panneau Gauche (1), le Panneau Droit (2), la Traverse Avant (4), la Traverse Arrière (5) et le Panneau Central (7).

(ES)

Inserte las Espigas (J) en el Panel Izquierdo (1), el Panel Derecho (2), el Travesaño Frontal (4), el Travesaño Trasero (5) y el Panel Central (7).

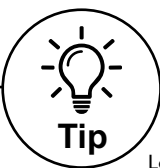
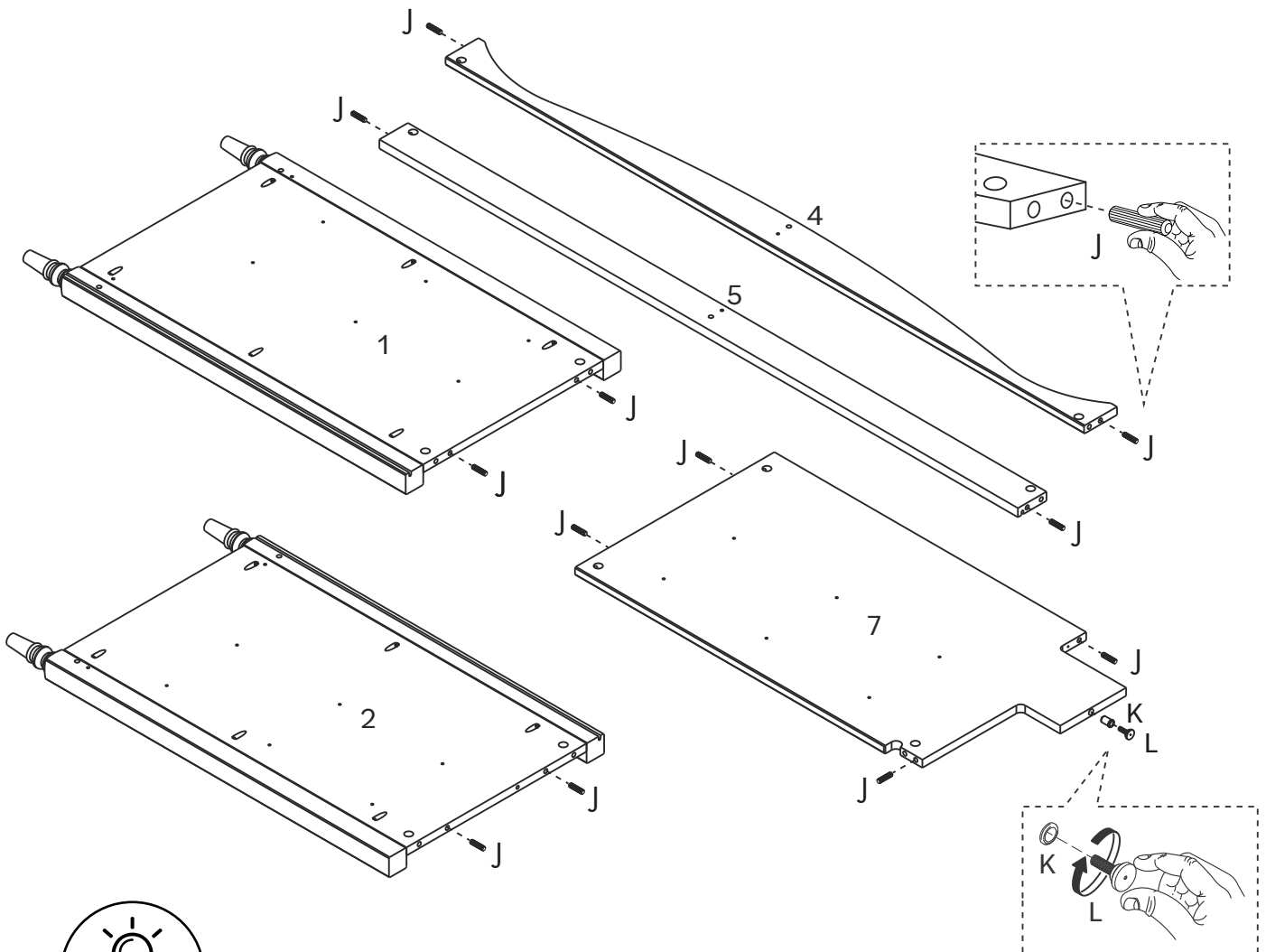

Cheville en bois

Les chevilles sont essentielles lors de l'assemblage de meubles pour créer des connexions solides et précises. Elles garantissent l'intégrité structurelle, empêchent les déplacements et simplifient l'alignement, ce qui permet d'obtenir des meubles plus résistants et plus durables. suis ces étapes :

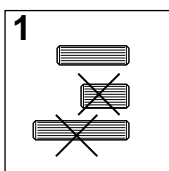

- 1: Sélectionne la taille de cheville appropriée en fonction de l'étape.
1: Seleccione el tamaño de espiga adecuado según el paso.

Espiga de madera

Las espigas son esenciales en el montaje de muebles para crear uniones fuertes y precisas. Garantizan la integridad estructural, evitan el desplazamiento y simplifican la alineación, lo que se traduce en muebles más resistentes y duraderos.

Sigue estos pasos:

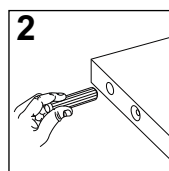

- 2: Insère dans le trou indiqué et appuie fermement pour assurer un positionnement correct.
2: Insértela en el orificio indicado y presione firmemente para asegurar su correcta colocación.

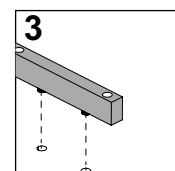

- 3: Alinee la cheville avec la pièce correspondante et enfonce-la jusqu'à ce qu'elle soit ferme.
3: Alinee el pasador con la pieza correspondiente y presiónelo hasta que encaje.

Étape / Paso 10



(FR)

Fixez les Goujons (M) au Panneau Gauche (1), au Panneau Droit (2), au Panneau Supérieur (3) et à la Traverse Avant (5).

(ES)

Fije los Conectores (M) al Panel Izquierdo (1), al Panel Derecho (2), al Panel Superior (3) y al Travesaño Frontal (5).

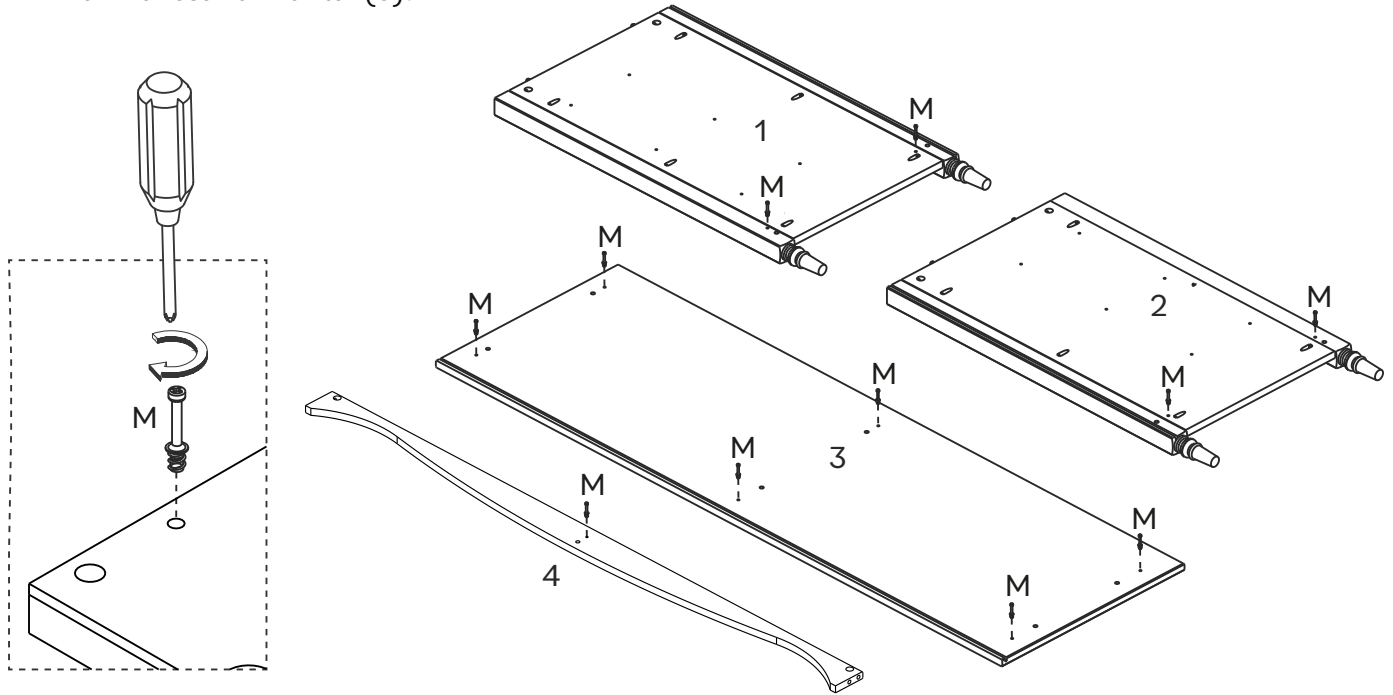

Étape / Paso 11



(FR)

Prenez la Glissière Extérieure (G1) et insérez l'Interlock Lock (E) conformément au schéma ci-dessous.

(ES)

Tome la Corredera Exterior (G1) e inserte el Interlock Lock (E) según el diagrama a continuación.

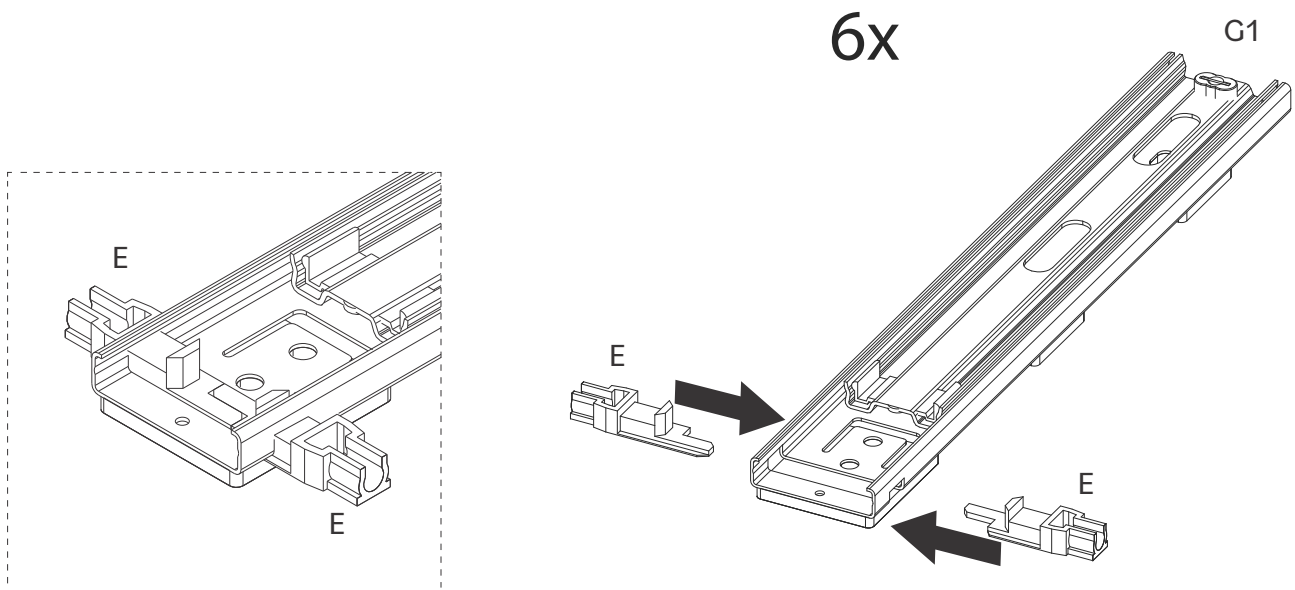

Étape / Paso 12



(FR)

Fixez la Glissière Extérieure (G1) au Panneau Droit (2) et au Panneau Gauche (1) à l'aide des Vis (F) et d'un tournevis cruciforme.

(ES)

Fije la Corredera Exterior (G1) al Panel Derecho (2) y al Panel Izquierdo (1) utilizando los Tornillos (F) y un destornillador Phillips.

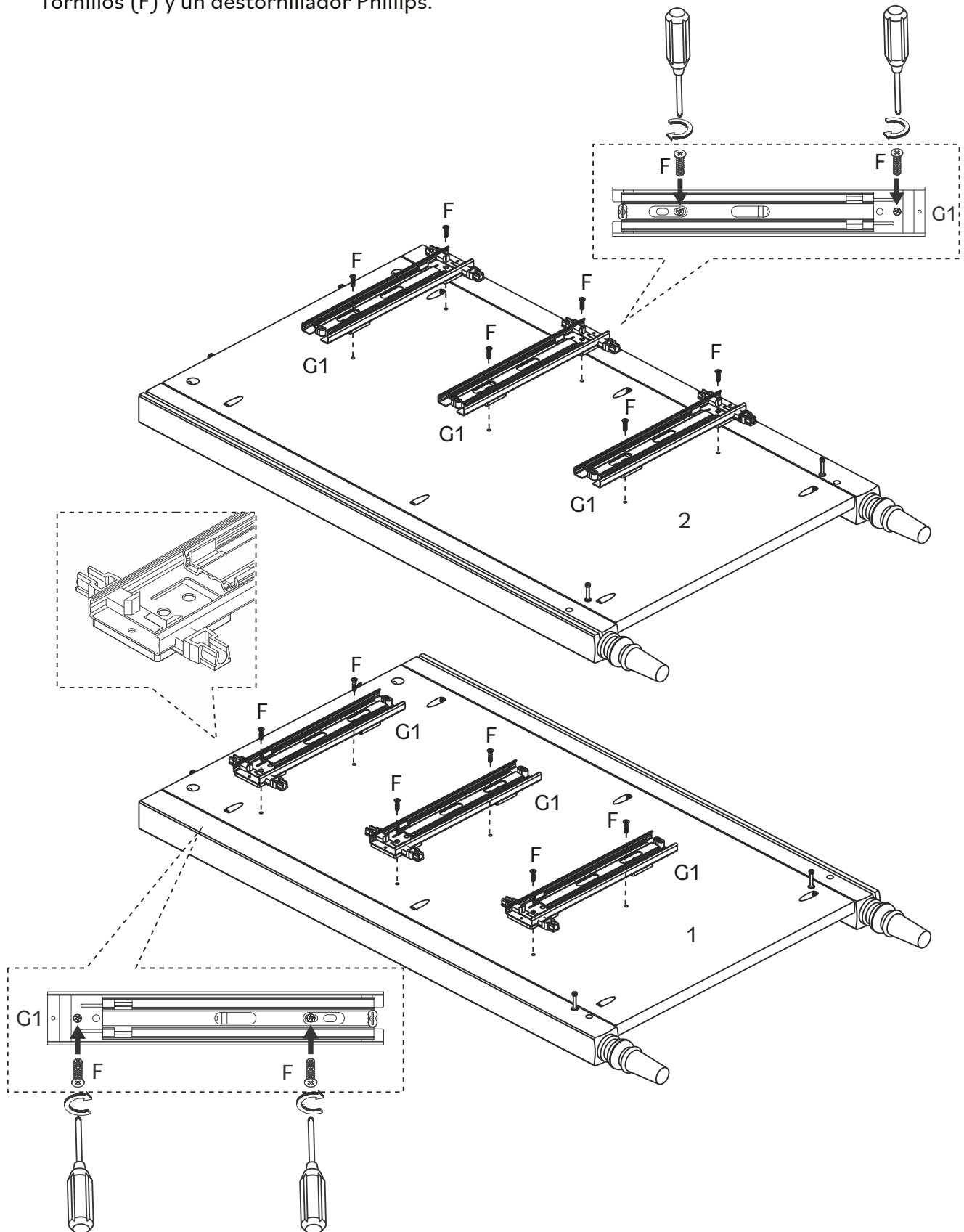

Étape / Paso 13

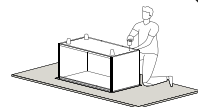

(FR)

Fixez la Glissière Extérieure (G1) des deux côtés du Panneau Central (7) à l'aide des Vis (F) et d'un tournevis cruciforme.

(ES)

Fije la Corredera Exterior (G1) a ambos lados del Panel Central (7) utilizando los Tornillos (F) y un destornillador Phillips.

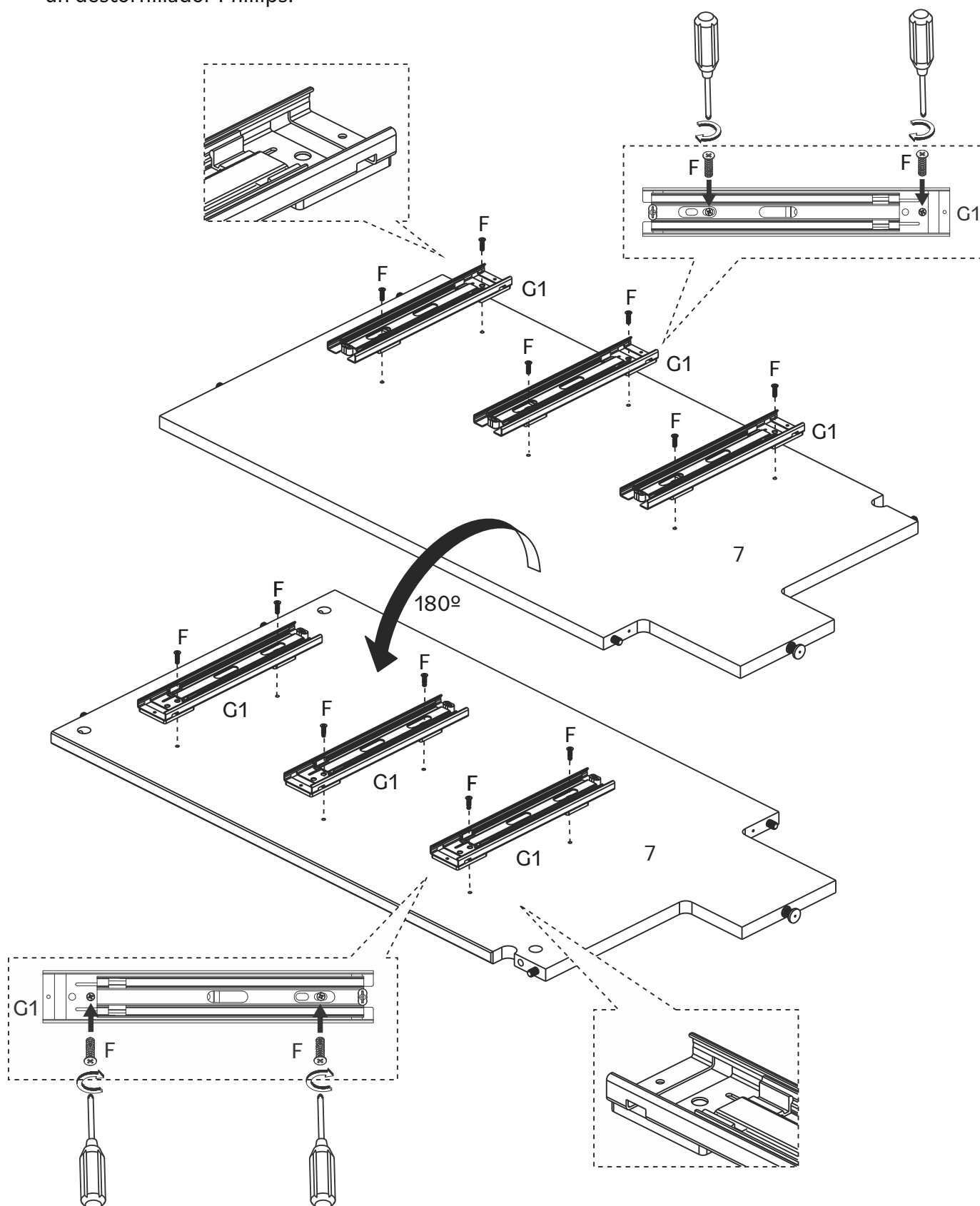

Étape / Paso 14

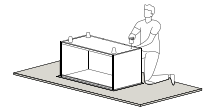

(FR)

Fixez la Traverse Arrière (5) au Panneau Droit (2) à l'aide du Boitier (N) et d'un tournevis cruciforme.

(ES)

Fije el Travesaño Trasero (5) al Panel Derecho (2) utilizando la Traba (N) y un destornillador Phillips.

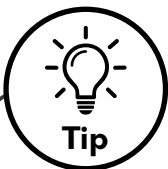
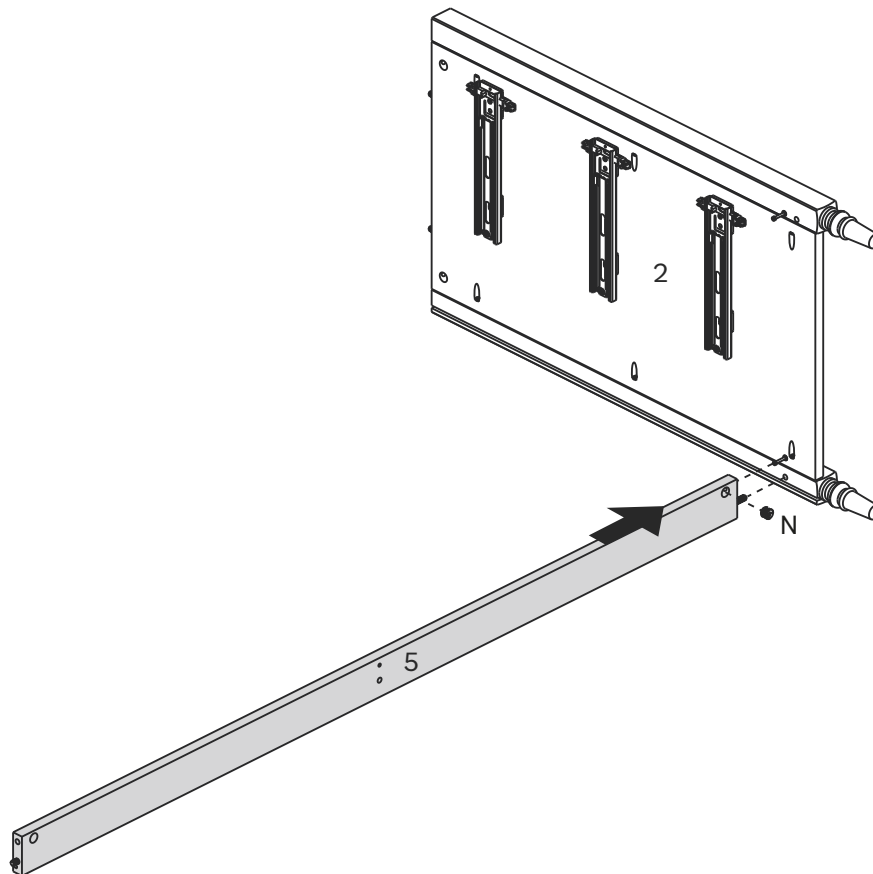

Tip

Goujon de Assemblage

Goujon de Assemblage permet de joindre deux pièces en toute sécurité. Suis ces étapes simples.

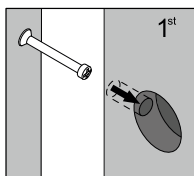

1: Insère le Goujon dans les orifices du côté plat. Ne serre pas trop !

1: Coloca el Conector en los orificios del lado plano. ¡No aprietes demasiado!

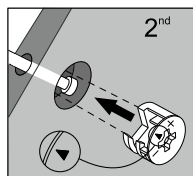

2: Joins les pièces en bois. Les Goujons entrent dans les orifices qui ont des trous sur les côtés, tu dois pouvoir voir les Goujons à travers ceux-ci. Après avoir installé les pièces, insère le Boitiers dans les orifices latéraux

2: Una las piezas de madera. Los Conectores entran en las piezas que tienen orificios en los lados, por lo que deberías poder ver los Conectores a través de ellos. Después de encajar las piezas, inserta la traba en los orificios laterales.

Conector

Los Conector ayudan a unir de forma segura dos piezas. Sigue estas fáciles etapas.

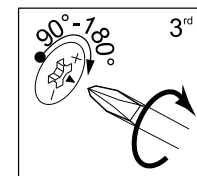

3: Sur la partie arrière du boitier, il aura la forme d'un « C ». Insère le boitier de manière à ce que l'ouverture « C » s'emboîte à la goujon. Serre-la avec le tournevis.

3: La parte posterior de la traba tendrá la forma de "C". Inserta el tambor de modo que la abertura de la "C" encaje en el Conector. Apriétalo con un destornillador.

Étape / Paso 15

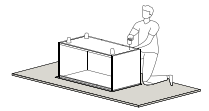

(FR)

Assemblez le Panneau Central (7) à la Traverse Arrière (5) en utilisant la Vis (Q) et un tournevis cruciforme.

(ES)

Una el Panel Central (7) al Travesaño Trasero (5) utilizando el Tornillo (Q) y un destornillador Phillips.

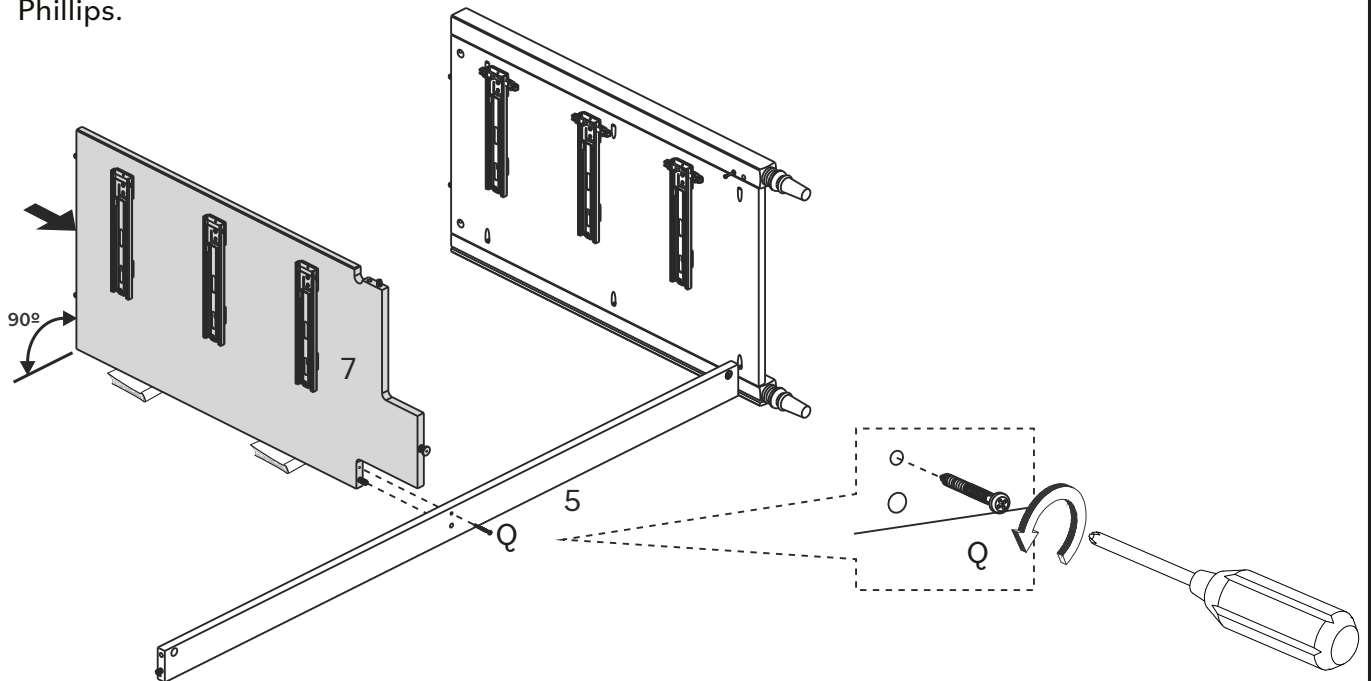

Étape / Paso 16



(FR)

Assemblez la Traverse Avant (4) au Panneau Droit (2) et au Panneau Central (7) en utilisant le Boitier (N) et un tournevis cruciforme.

(ES)

Una el Travesaño Frontal (4) al Panel Derecho (2) y al Panel Central (7) utilizando la Traba (N) y un destornillador Phillips.

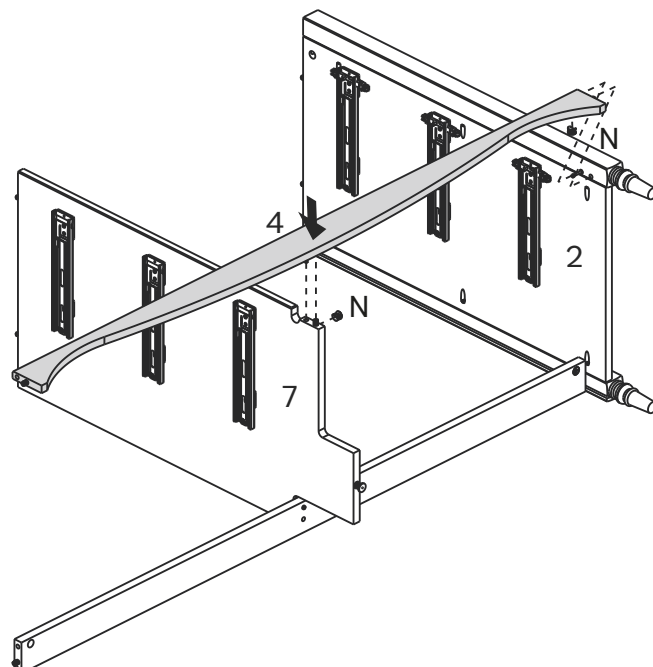
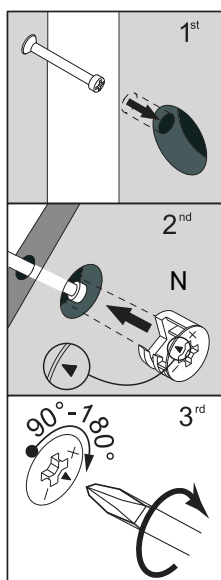

Étape / Paso 17



(FR)

Assemblez le Panneau Gauche (1) à la Traverse Avant (4) et à la Traverse Arrière (5) en utilisant le Boitier (N) et un tournevis cruciforme.

(ES)

Una el Panel Izquierdo (1) al Travesaño Frontal (4) y al Travesaño Trasero (5) utilizando la Traba (N) y un destornillador Phillips.

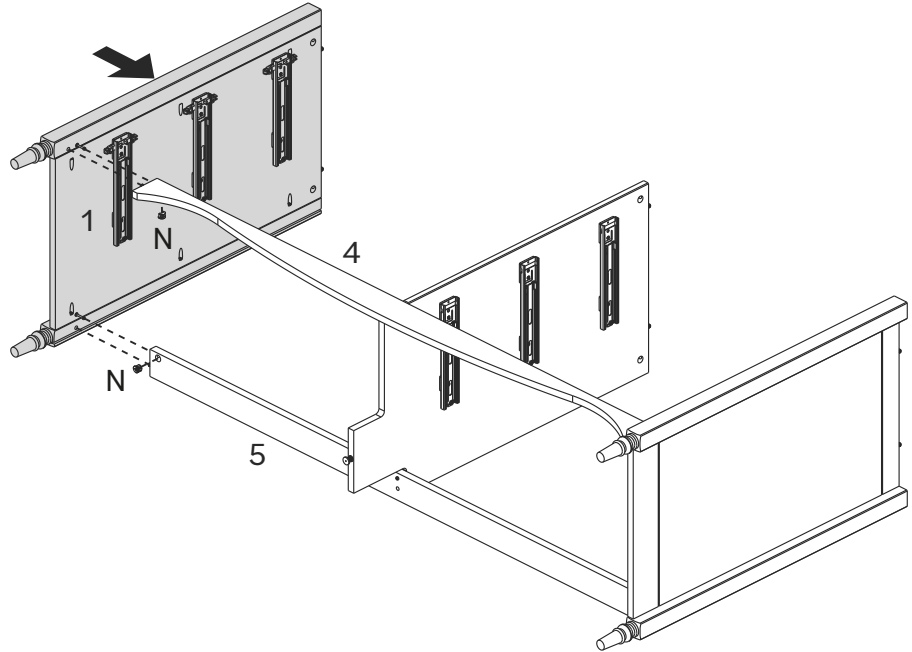
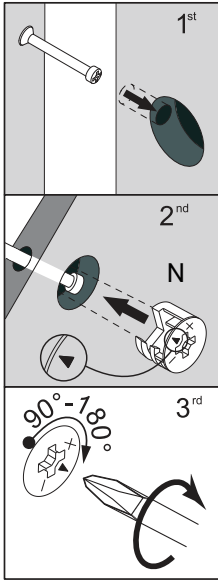

Étape / Paso 18



(FR)

Faites glisser le Panneau Arrière (6) dans les rainures du Panneau Gauche (1) et du Panneau Droit (2) en l'insérant dans la Traverse Arrière (5).

(ES)

Deslice el Panel Trasero (6) en las ranuras del Panel Izquierdo (1) y del Panel Derecho (2) encajándolo en el Travesaño Trasero (5).

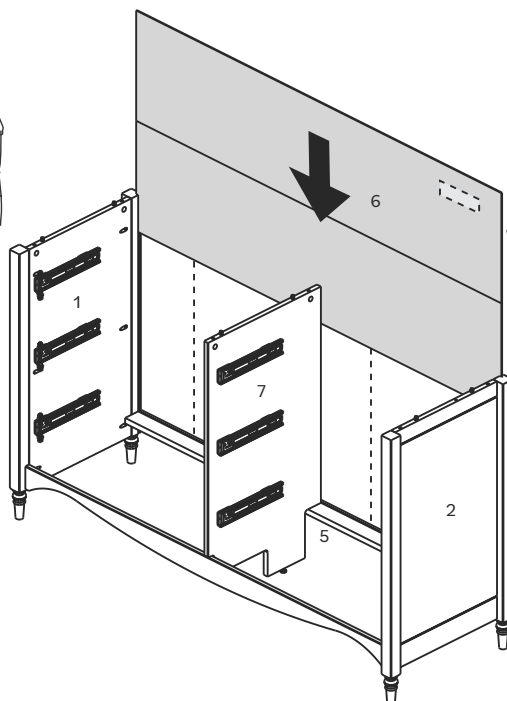
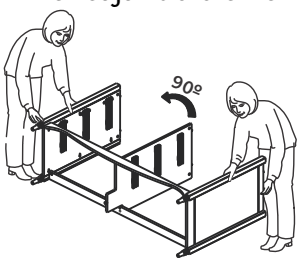

Nom et adresse du fournisseur
et date de production.
Nombre y dirección del
proveedor y fecha de fabricación.

L'étiquette de traçabilité doit
être orientée vers l'extérieur
La etiqueta de trazabilidad debe
quedar orientada hacia afuera

Étape / Paso 19



(FR)

Fixez le Panneau Supérieur (3) au Panneau Gauche (1), au Panneau Droit (2) et au Panneau Central (7) en utilisant les Boitiers (N) et un tournevis cruciforme.

(ES)

Fije el Panel Superior (3) al Panel Izquierdo (1), al Panel Derecho (2) y al Panel Central (7) utilizando las Trabas (N) y un destornillador Phillips.

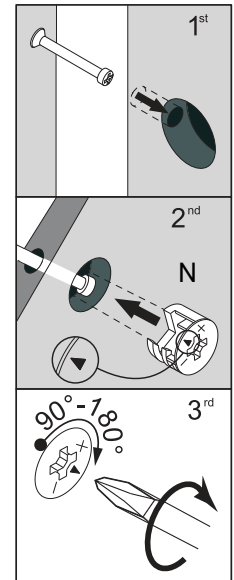
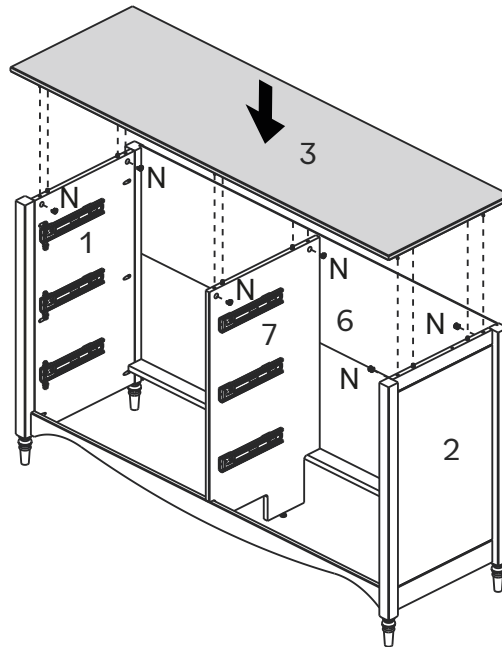

Étape / Paso 20



(FR)

Fixez le Panneau Arrière (6) en insérant la Cale (P) et la vis (V) entre le panneau et les rainures. Utilisez un tournevis Phillips.

(ES)

Asegure el Panel Trasero (6) colocando la Cuña (P) y el tornillo (V) entre el panel y las ranuras. Use un destornillador Phillips.

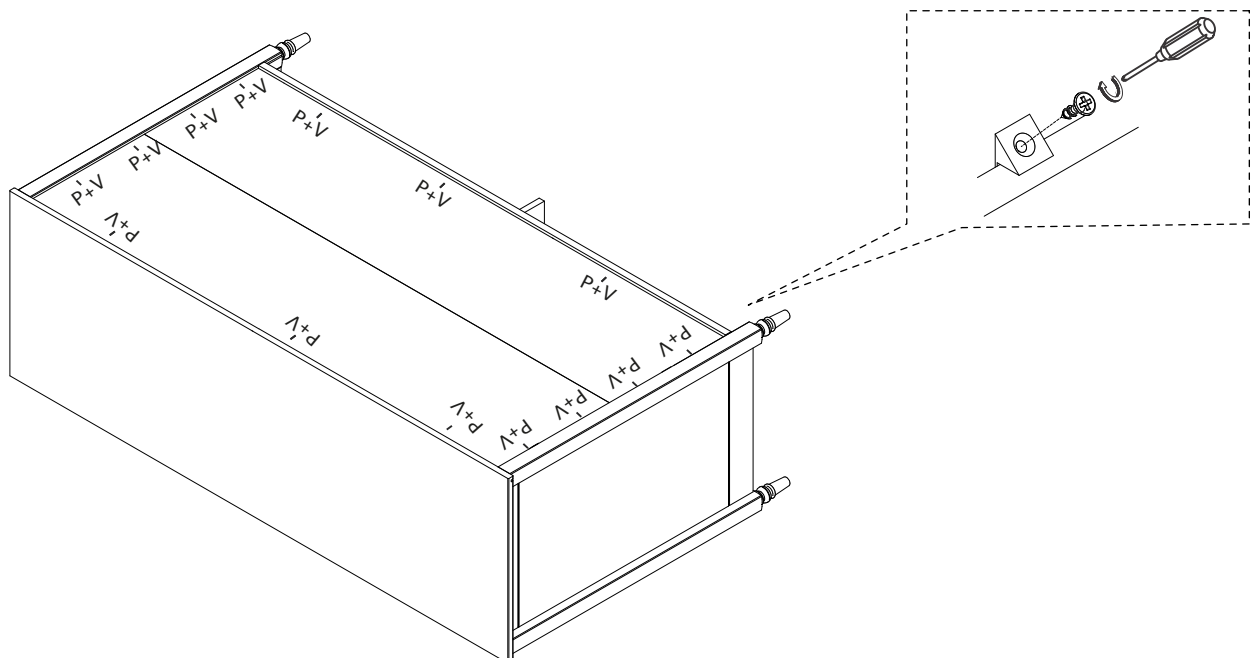

Étape / Paso 21

(FR)
Fixez l'Interlock Bar (E) dans les Locks (O).

(ES)
Fije el Interlock Bar (E) en los Locks (O).

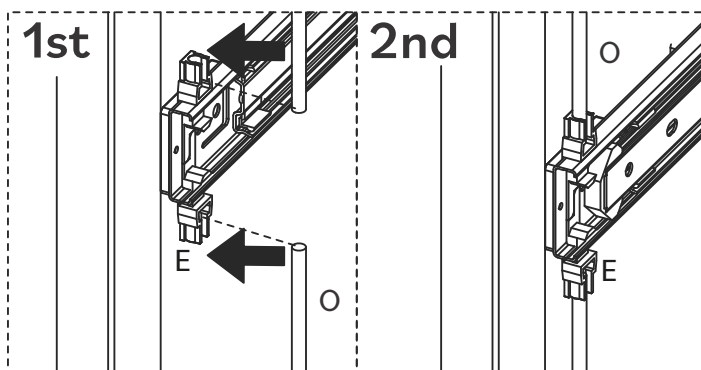
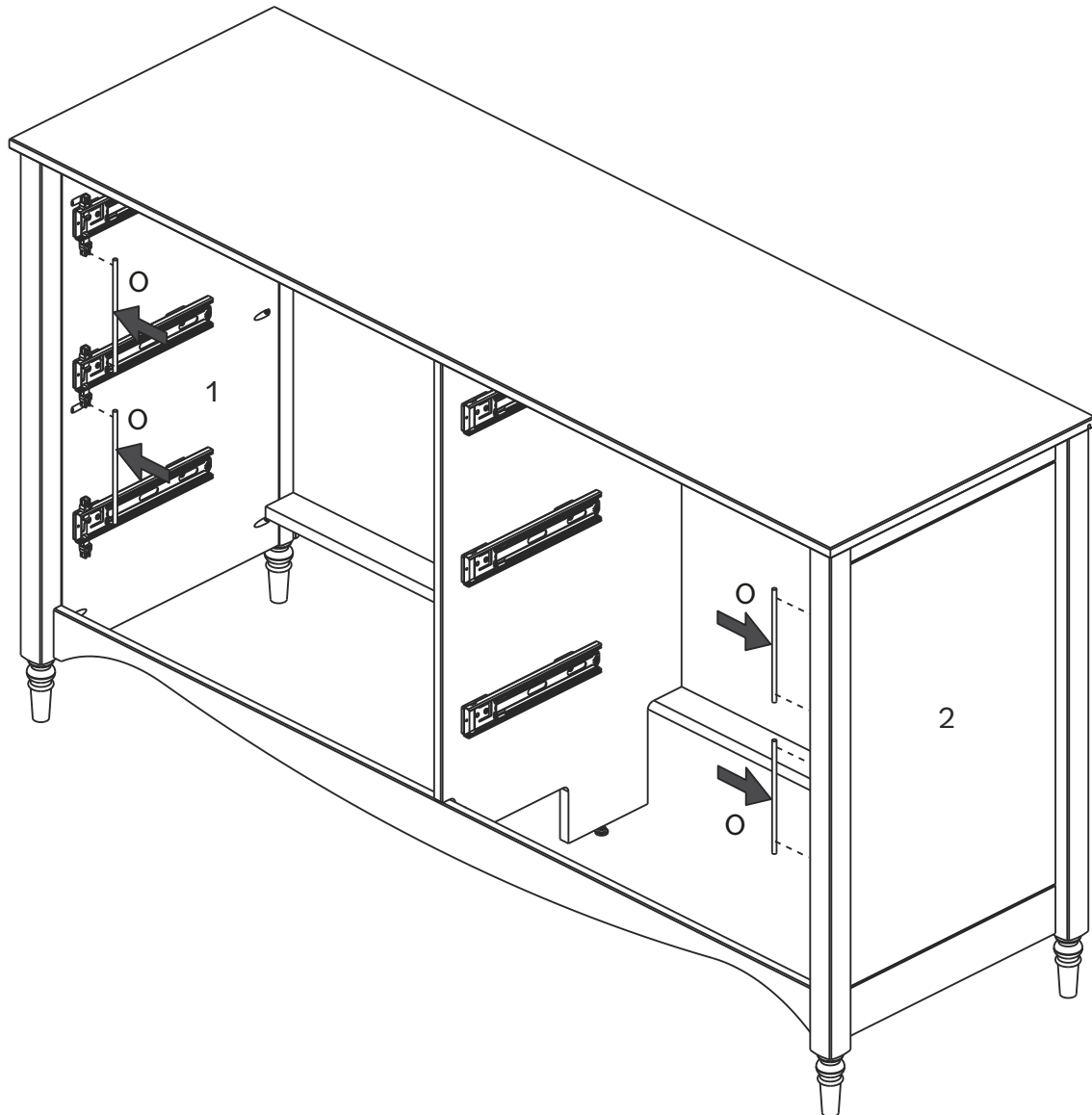

Étape / Paso 22

(FR)

Placez les tiroirs un par un en utilisant les glissières, veillez à bien les positionner en alignant la Glissière Extérieure et la Glissière Intérieure.

(ES)

Coloque los cajones uno por uno utilizando las correderas, asegúrese de posicionarlos correctamente alineando la Corredera Exterior y la Corredera Interior.

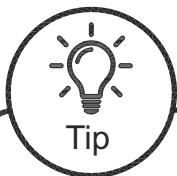
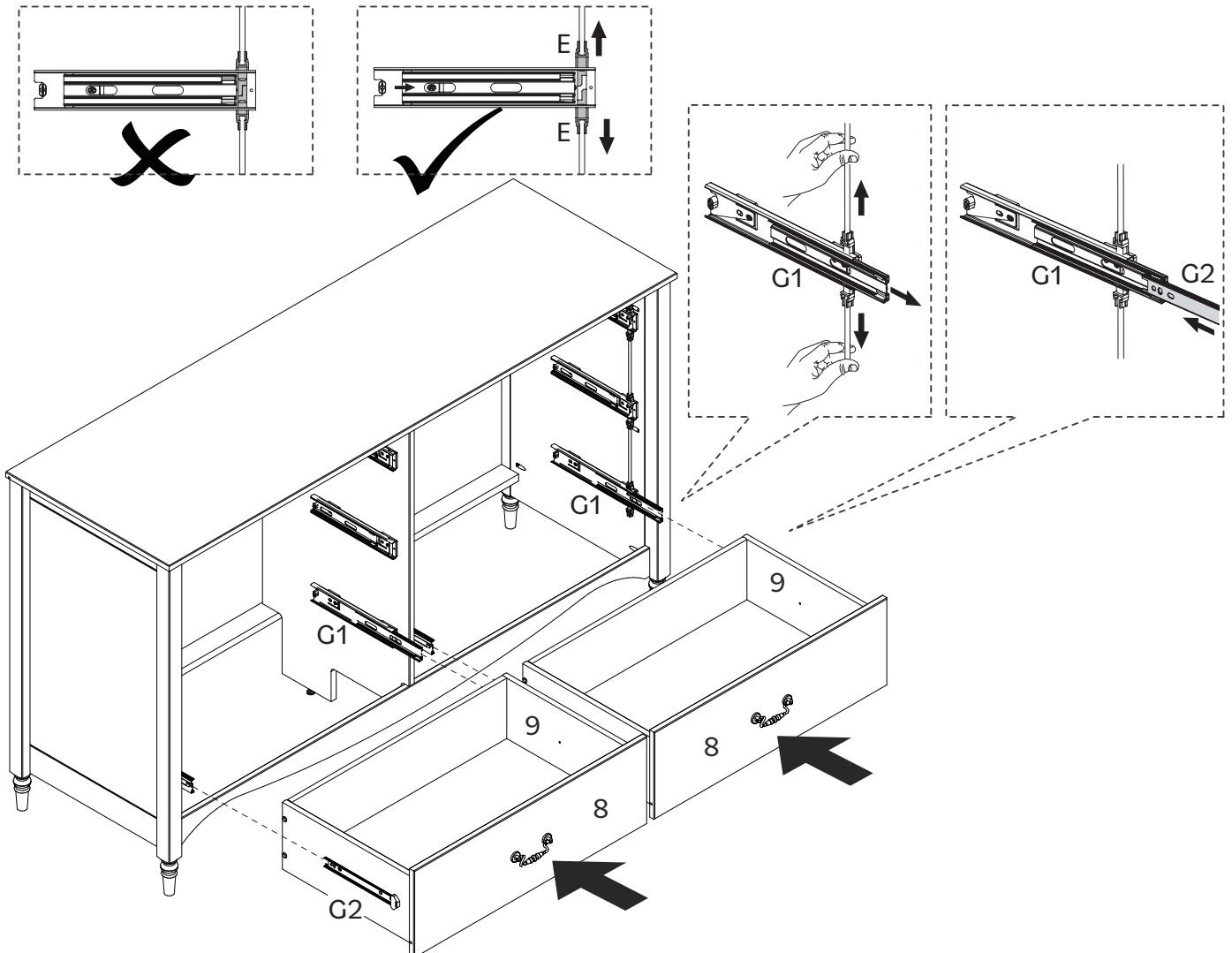

Tip

Insérez correctement le tiroir de votre armoire

Alignez les glissières extérieure et intérieure et poussez légèrement le tiroir à l'intérieur du meuble. Une fois la connexion établie, poussez le tiroir jusqu'à ce qu'il soit bien en place. Le glissement peut être délicat au début, mais il s'améliore une fois la connexion établie.

Inserte el cajón de su gabinete correctamente

Alinee las correderas exterior e interior y empuje el cajón ligeramente dentro de la unidad. Una vez que sienta la conexión, empujélo hasta que encaje completamente. Puede que al principio no se deslice con suavidad, pero mejora una vez que esté completamente conectado.

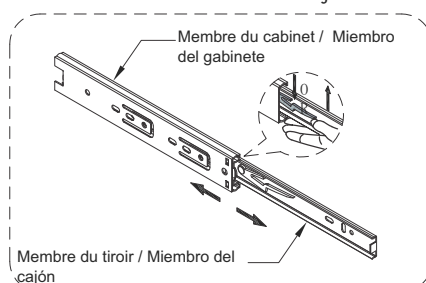

Étape / Paso 23

(FR)

Placez les tiroirs un par un en utilisant les glissières, veillez à bien les positionner en alignant la Glissière Extérieure et la Glissière Intérieure.

(ES)

Coloque los cajones uno por uno utilizando las correderas, asegúrese de posicionarlos correctamente alineando la Corredera Exterior y la Corredera Interior.

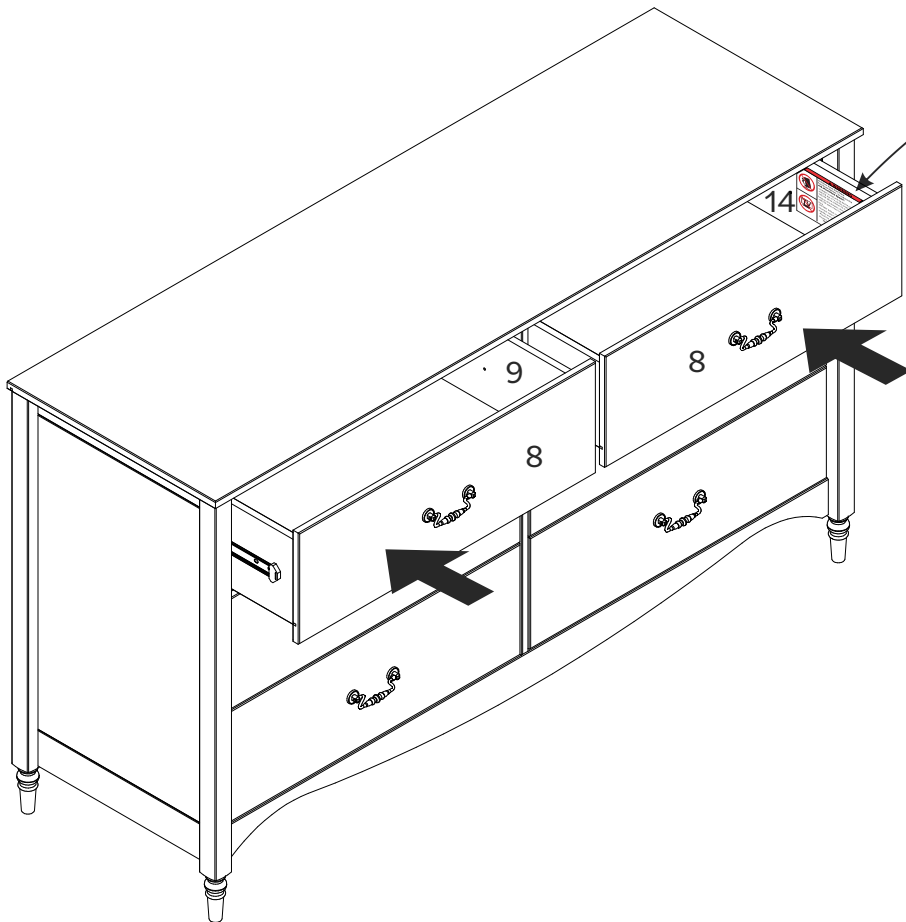

▲ WARNING	
	<p>Children have died from furniture tipover. To reduce the risk of furniture tipover:</p> <ul style="list-style-type: none"> -ALWAYS install anti tip device provided. -NEVER put a TV on this product. -NEVER allow children to stand, climb or hang on any drawers, doors, or shelves. -NEVER open more than one drawer at a time. -DO NOT defeat or remove the drawer interlock system; it is an important stability and safety system. -Place heaviest items in the lowest drawers. <p><i>This is a permanent label. Do not remove!</i></p>
	<p>DO NOT remove the interlock system except for maintenance as shown. NEVER use the unit without the interlock installed following the instructions.</p> <p>System Specific Instructions for interlock installation.</p> <p>Insert Interlock Lock on the sliders. After securing the sliders to the cabinet, attach the Interlock Bars to the Locks. Once this is done you can place the drawer one at a time. To remove the drawer push the locks in the sliders</p>

Le tiroir portant l'étiquette d'avertissement doit être positionné en haut.

El cajón con la etiqueta de advertencia debe colocarse en la posición más alta.

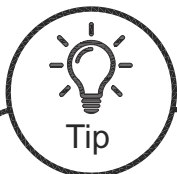
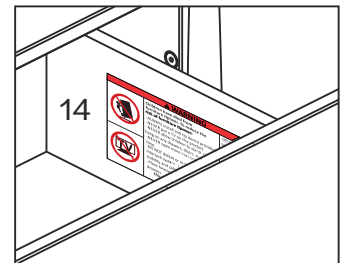

Retrait du tiroir

Il y a un levier blanc dans chaque glissière.
Pour retirer les tiroirs,
tirez le tiroir jusqu'à ce que vous voyiez le levier.
Poussez un levier vers le haut et l'autre vers le bas,
tout en poussant, tirez le tiroir vers l'extérieur.

Extracción del cajón

Hay una palanca blanca en cada riel. Para quitar los cajones,
tire del cajón hasta que vea la palanca.
Empuje una palanca hacia arriba y la otra hacia abajo,
y mientras empuja, saque el cajón.

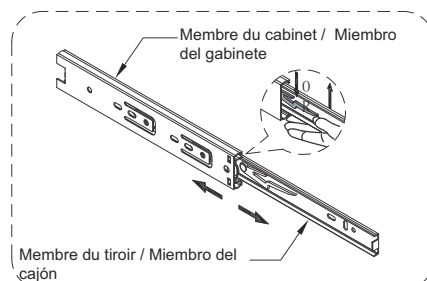

Étape / Paso 24

(FR)

Pour terminer, installez le kit anti-basculement. Fixez l'Ancrage Mural (R) au Panneau Supérieur (3) en utilisant la Rondelle (U), la Vis (R) et un tournevis cruciforme en suivant les détails du schéma ci-dessous.

(ES)

Para finalizar, instale el kit antivuelco. Fije el Anclaje de Pared (R) al Panel Superior (3) utilizando la Arandela (U), el Tornillo (R) y un destornillador Phillips siguiendo los detalles del diagrama a continuación.

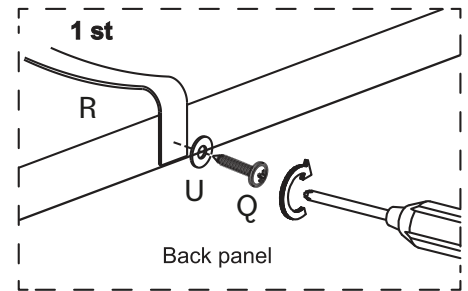
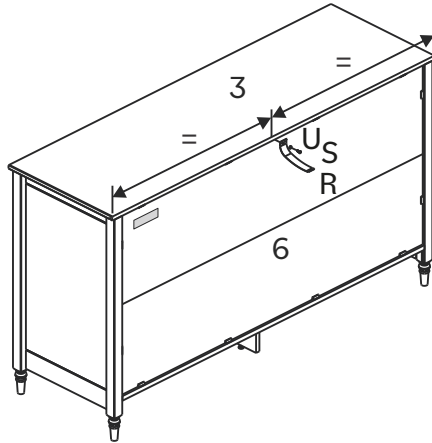

Étape / Paso 25

(FR)

Dernière étape ! Insérez la Douille en Plastique (T) dans le mur. Ensuite, fixez l'Ancrage Mural (R) au mur à l'aide de la Rondelle (U) et de la Vis (Q).

(ES)

¡Último paso! Inserte el Casquillo de Plástico (T) en la pared. Luego, fije el Anclaje de Pared (R) a la pared utilizando la Arandela (U) y el Tornillo (Q).

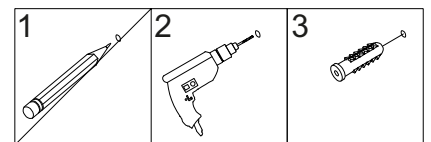
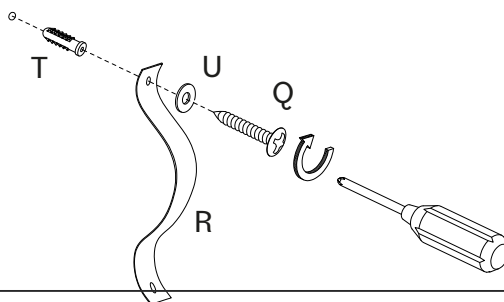

Avertissement

Des blessures graves, voire mortelles, peuvent survenir en cas de renversement de meubles. Pour éviter que le meuble ne bascule, nous recommandons de le fixer définitivement au mur. L'ancrage mural et les autres composants sont inclus dans ce produit. Assure-toi que les composants sont adaptés à tes murs avant l'installation, car différents matériaux de mur peuvent nécessiter différents types d'ancrages.

Le nom et l'adresse du fabricant responsable des composants anti-basculer ainsi que la date de production se trouvent sur l'étiquette au dos du meuble.

Advertencia

Pueden ocurrir lesiones graves o fatales debido a la caída de muebles. Para evitar que los muebles se caigan, recomendamos que se fijen permanentemente a la pared. El anclaje de pared y los herrajes están incluidos en este producto. Asegúrate de que los herrajes sean adecuados para tus paredes antes de la instalación, ya que diferentes materiales de pared pueden requerir diferentes tipos de anclajes.

El nombre y la dirección del fabricante responsable de los herrajes antivuelco y la fecha de producción se pueden encontrar en la etiqueta de la parte trasera de los muebles.

À démonter / Para desmontar



(FR)

S'il est nécessaire de démonter, retirez le Dovetail Lock (B) à l'aide d'un tournevis à tête plate.

(ES)

Si es necesario desmontarlo, retire el Dovetail Lock (B) con un destornillador de cabeza ranurada.

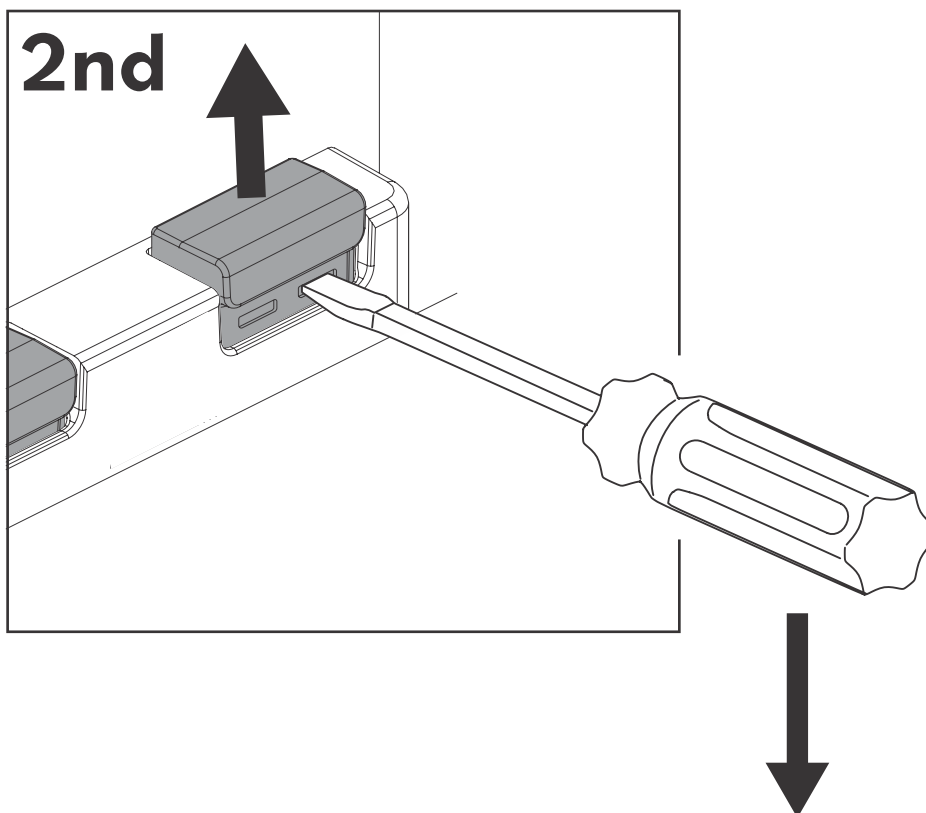
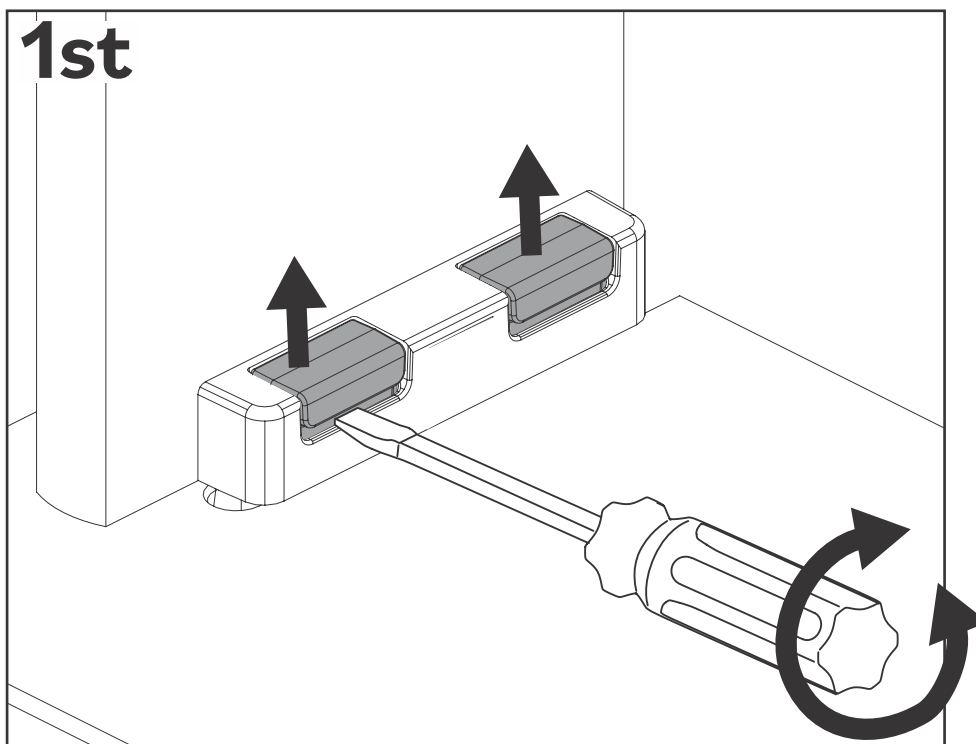

Tu as réussi ! Profite de ton nouveau Commode à tiroirs!
¡Lo ha conseguido! ¡Disfrute de su nueva Cómoda con cajones!

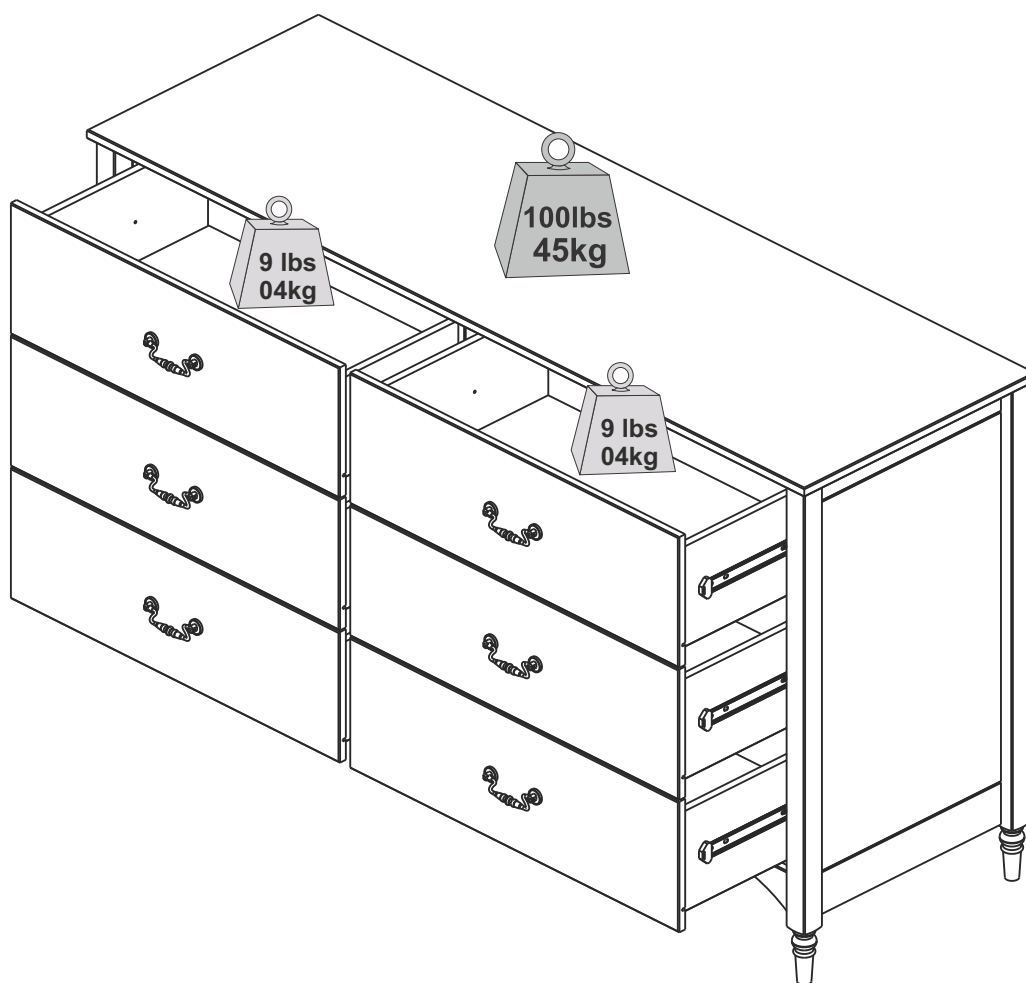

Bravo pour ton nouveau meuble !

¡Enhorabuena por sus nuevos muebles!