



Manufactured by:  
Backyard Discovery  
3305 Airport Drive, Pittsburg, KS 66762  
800-856-4445

Basepoint Business Centre: Rivermead Drive, Westlea, Swindon SN5 7EX Phone: 0800-118-2476 J.P. Coenstraat 7, The Bridge, The Hague, 2595 WP, Netherlands  
Phone: 08005678990

# 16x12 Barrington Gazebo EU

## MODEL # : 2306141B



Please visit [www.backyarddiscovery.com](http://www.backyarddiscovery.com)  
For the most up to date assembly manual, to register your product, or to order  
replacement parts *Para obtener instrucciones en español, visite*  
[www.backyarddiscovery.com](http://www.backyarddiscovery.com)



EASY STEP-BY-STEP  
3D INTERACTIVE INSTRUCTIONS  
DOWNLOAD THE FREE APP



# OWNER'S MANUAL - BASIC SETUP DIMENSIONS & ASSEMBLY NOTES

It is critically important that you start with square and level footings, concrete pad or deck to attach your structure

- Pay close attention to the items needed for each step. Make sure you are using the correct hardware for each step. Using incorrect hardware may result in improper assembly
- Remember to double check for underground utilities and overhead electrical lines

**Post mounts are provided with your structure which allows you to permanently install your structure to a pre-existing or new wood or concrete surface. See Anchor Instructions for further details and recommendations.**

- The hardware to attach the post mounts to the structure is included.
- The hardware to mount the structure permanently to a concrete surface is included.
- The hardware to mount the structure permanently to a wood deck is NOT included and will need to be purchased separately. You must ensure there is ample structural support under the deck before permanently attaching.

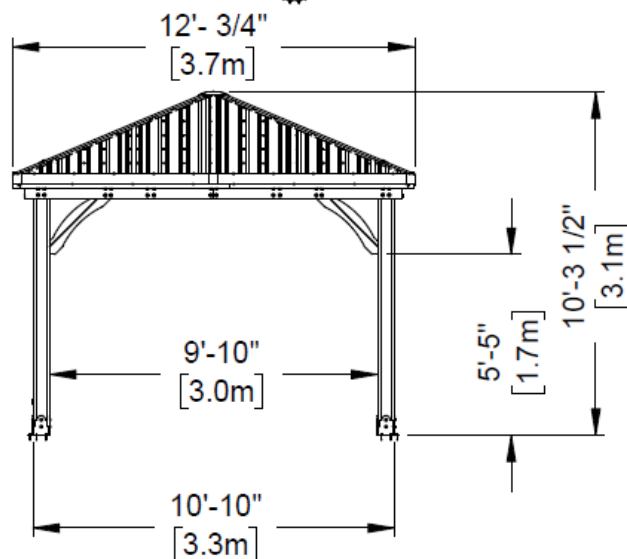
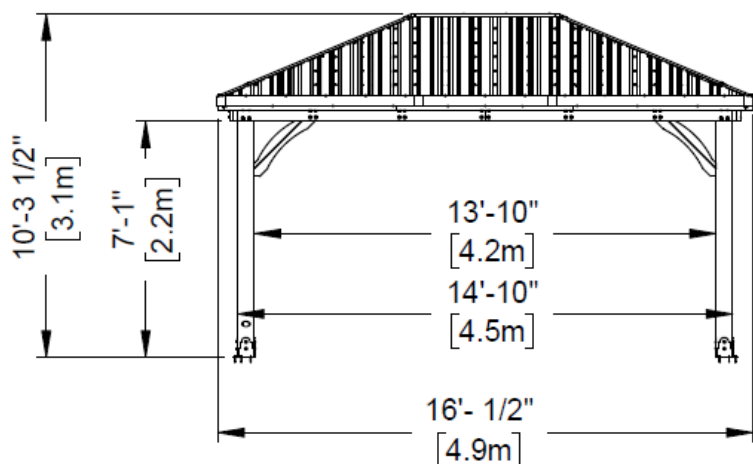
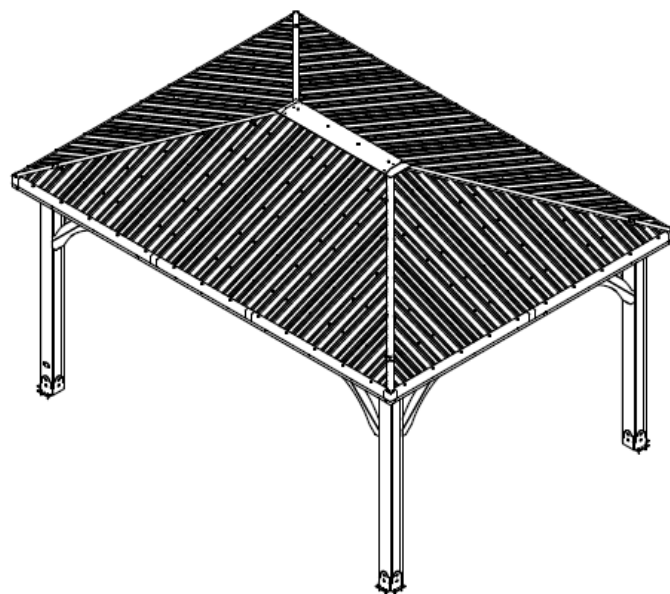
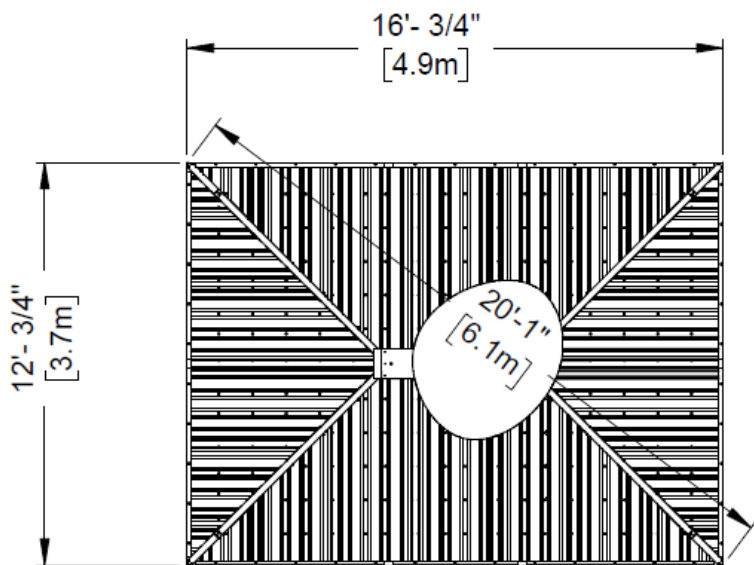

# OWNER'S MANUAL - ANCHORING LAYOUT

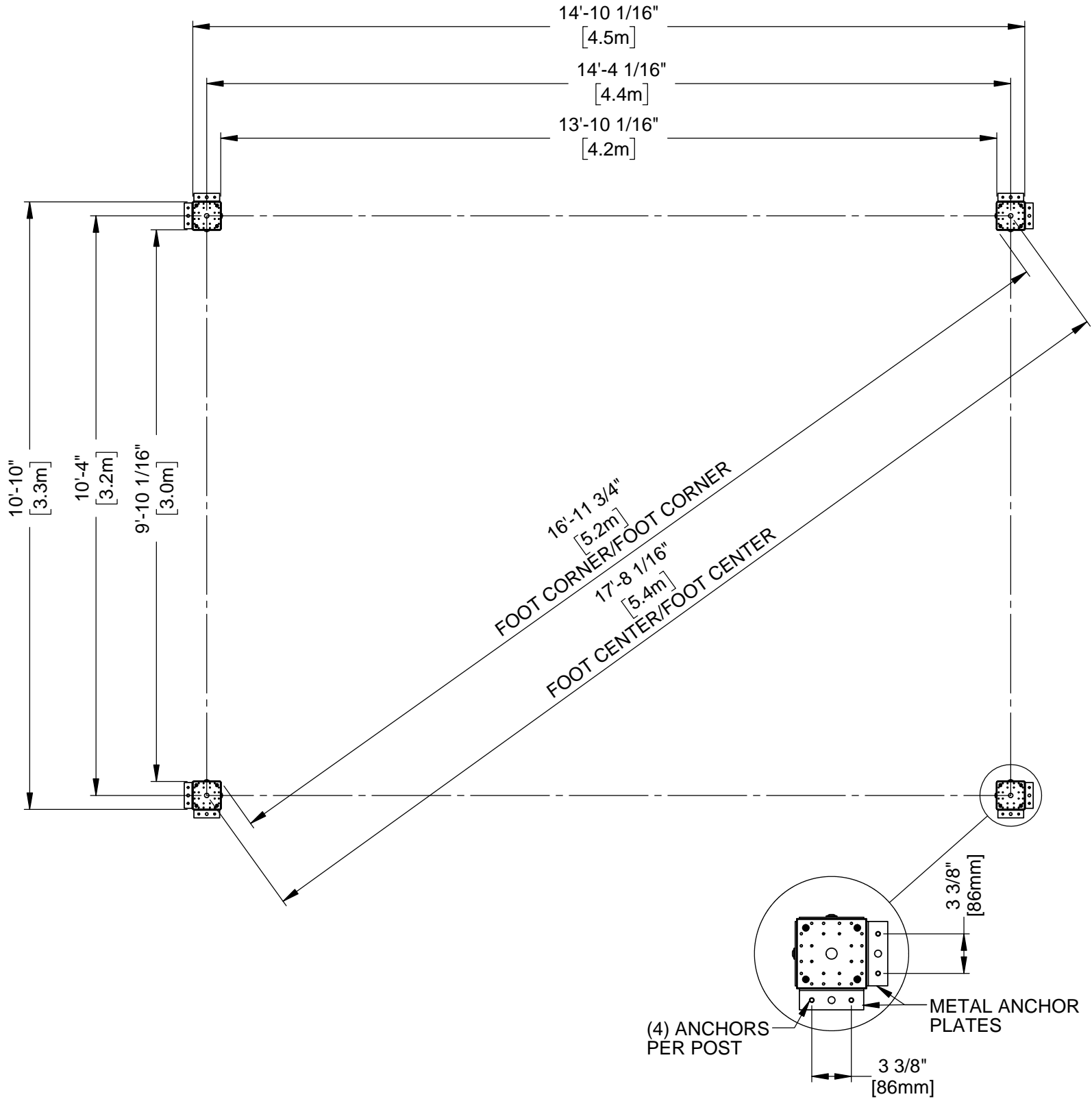

# OWNER'S MANUAL - PARTS IDENTIFICATION

## Wood Components (Not to Scale)



**H01** | ROOF SUPPORT- W4L15194  
(4) | 1"x3 3/8"x54 1/8" (24x86x1374)



**H02** | ROOF JOIST- W4L15289  
(2) | 1"x3 3/8"x61 1/4" (24x86x1556)



**H03** | ROOF JOIST - W4L15288  
(2) | 1"x3 3/8"x46 7/8" (24x86x1556)



**H04** | ROOF SUPPORT - W4L15314  
(4) | 1"x3 3/8"x38 13/16" (24x86x986)

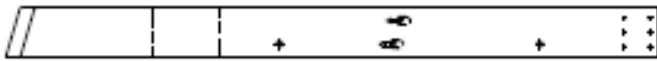

**H05** | ROOF JOIST - W4L15293  
(2) | 1"x3 3/8"x44 1/2" (24x86x1130)

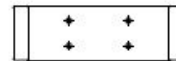

**H06** | ROOF JOIST - W4L15203  
(2) | 1"x3 3/8"x10 11/16" (24x86x272)



**H07** | ROOF JOIST - W4L15315  
(2) | 1"x3 3/8"x53 3/16" (24x86x1351)



**H08** | ROOF JOIST - W4L15316  
(2) | 1"x3 3/8"x53 3/16" (24x86x1351)



**H09** | ROOF JOIST- W4L15297  
(2) | 1"x3 3/8"x61 1/4" (24x86x1556)



**H10** | ROOF JOIST- W4L15298  
(2) | 1"x3 3/8"x44 1/2" (24x86x1130)



**H11** | ROOF JOIST- W4L15216  
(2) | 1"x3 3/8"x44 1/2" (24x86x1130)



**H12** | ROOF JOIST- W4L15220  
(2) | 1"x3 3/8"x44 1/2" (24x86x1130)

# OWNER'S MANUAL - PARTS IDENTIFICATION

## Wood Components (Not to Scale)

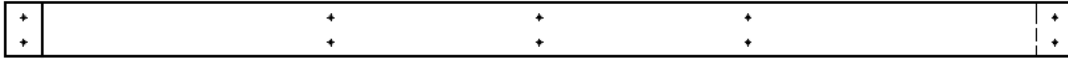

**H13 | PURLIN - W4L15302**  
(2) | 1"x3 3/8"x68 1/2" (24x86x1740)

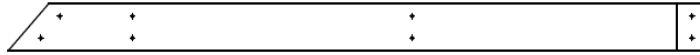

**H14 | PURLIN - W4L15303**  
(4) | 1"x3 3/8"x54 1/8" (24x86x1374)

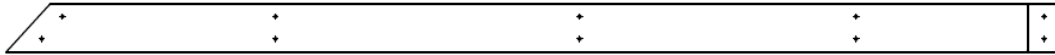

**H15 | PURLIN - W4L15304**  
(4) | 1"x3 3/8"x75 1/16" (24x86x1906)

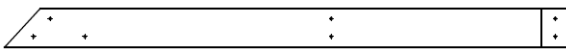

**H16 | PURLIN - W4L15305**  
(4) | 1"x3 3/8"x49 9/16" (24x86x1259)



**H17 | PURLIN - W4L15306**  
(2) | 1"x1 3/8"x29 1/8" (24x86x740)

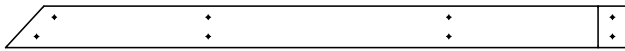

**H18 | PURLIN - W4L15307**  
(4) | 1"x3 3/8"x50 13/16" (24x86x1291)



**H19 | PURLIN - W4L15228**  
(2) | 1"x3 3/8"x58 5/16" (24x86x1481)



**H20 | PURLIN - W4L15229**  
(2) | 1"x3 3/8"x43 7/8" (24x86x1114)



**H21 | PURLIN - W4L15230**  
(2) | 1"x3 3/8"x75 11/16" (24x86x1922)



**H22 | PURLIN - W4L15231**  
(2) | 1"x3 3/8"x51 7/16" (24x86x1307)



**H24 | PURLIN W4L15232**  
(2) | 1"x3 3/8"x27 1/4" (24x86x692)

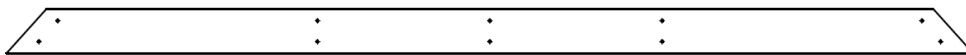

**H25 | PURLIN - W4L15308**  
(2) | 1"x3 3/8"x75 1/16" (24x86x1907)



**H27 | PURLIN - W4L15237**  
(2) | 1"x3 3/8"x56" (24x86x1422)

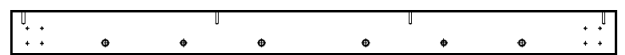

**H29 | ROOF SUPPORT - W4L15286**  
(1) | 1"x3 3/8"x48" (24x86x1219)

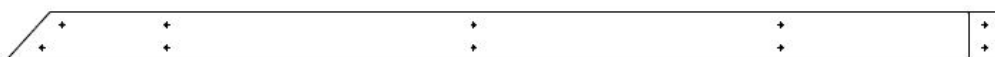

**H28 | PURLIN - W4L15238**  
(2) | 1"x3 3/8"x70 1/2" (24x86x1791)

# OWNER'S MANUAL - PARTS IDENTIFICATION

## Wood Components (Not to Scale)



**E01** | RAFTER- W4L15312  
(4) | 1 3/8"x3 3/8"x76 11/16" (36x86x1948)



**E02** | RAFTER- W4L15290  
(2) | 1 3/8"x3 3/8"x67 1/8" (36x86x1705)



**E03** | RAFTER- W4L15291  
(2) | 1 3/8"x3 3/8"x43 5/8" (36x86x1109)



**E04** | RAFTER- W4L15292  
(2) | 1 3/8"x3 3/8"x20 3/16" (36x86x512)



**E05** | RAFTER - W4L15207  
(2) | 1 3/8"x3 3/8"x69" (36x86x1752)



**E06** | RAFTER - W4L15208  
(2) | 1 3/8"x3 3/8"x45 7/16" (36x86x1155)



**E07** | RAFTER- W4L15209  
(2) | 1 3/8"x3 3/8"x21 15/16" (36x86x557)

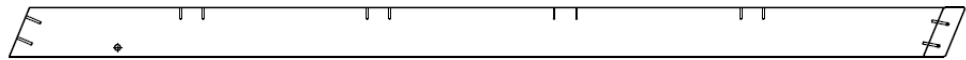

**E08** | RAFTER - W4L15294  
(2) | 1 3/8"x3 3/8"x67 1/8" (36x86x1705)

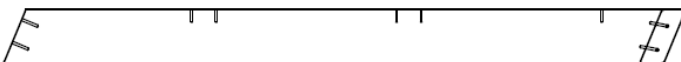

**E09** | RAFTER - W4L15295  
(2) | 1 3/8"x3 3/8"x43 5/8" (36x86x1109)



**E10** | RAFTER- W4L15296  
(2) | 1 3/8"x3 3/8"x20 3/16" (36x86x512)



**E11** | RAFTER- W4L15217  
(2) | 1 3/8"x3 3/8"x69" (36x86x1752)



**E12** | RAFTER W4L15218  
(2) | 1 3/8"x3 3/8"x45 7/16" (36x86x1155)



**E13** | RAFTER- W4L15219  
(2) | 1 3/8"x3 3/8"x21 15/16" (36x86x557)



**E14** | RAFTER- W4L15299  
(2) | 1 3/8"x3 3/8"x76 11/16" (36x86x1948)

# OWNER'S MANUAL - PARTS IDENTIFICATION

## Wood Components (Not to Scale)



**C01** | CORBEL- W2A03198  
(7) | 1 7/16"x6 7/16"x35 1/8" (36x163x893)



**C02** | CORBEL W/TAG- W2A03199  
(1) | 1 7/16"x6 7/16"x35 1/8" (36x163x893)



**G01** | COVER BOARD - W4L15313  
(2) | 1 "x5 1/4"x89 1/2" (24x134x2274)



**D02** | BEAM - W4L15284  
(4) | 1 3/8"x5 1/4"x89" (36x134x2261)



**D01** | BEAM- W4L15192  
(4) | 1 3/8"x5 1/4"x45 3/16" (36x134x1148)



**D03** | BEAM - W4L15283  
(2) | 1 3/8"x5 1/4"x59 15/16" (36x134x1522)



**D04** | BEAM - W4L15282  
(4) | 1 3/8"x5 1/4"x59 1/16" (36x134x1500)

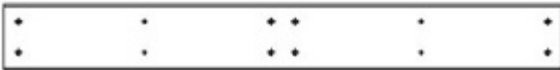

**D05** | BEAM - W4L15240  
(2) | 1 3/8"x5 1/4"x45 1/4" (36x134x1150)

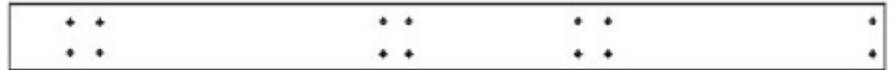

**D06** | BEAM - W4L15241  
(4) | 1 3/8"x5 1/4"x67 13/16" (36x134x1723)



**Q01** | ROOF JOIST- W4L15204  
(2) | 1"x4 7/16"x65 15/16" (24x112x1675)

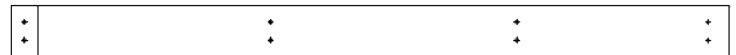

**Q02** | ROOF JOIST- W4L15300  
(4) | 1"x4 7/16"x63 13/16" (24x112x1605)



**Q03** | ROOF JOIST- W4L15221  
(2) | 1"x4 7/16"x80 1/2" (24x112x2044)

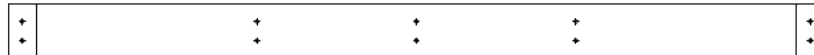

**Q04** | ROOF JOIST- W4L1301  
(2) | 1"x4 7/16"x68 1/2" (24x112x1740)

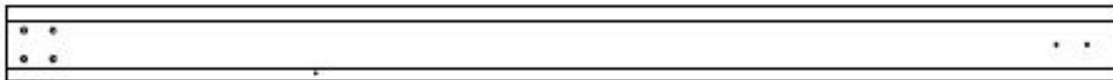

**P01** | POST - W2A03202  
(2) | 6"x6"x89 1/2" (152x152x2274)

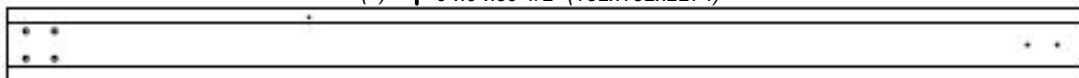

**P02** | POST - W2A03203  
(2) | 6"x6"x89 1/2" (152x152x2274)



**T01** | PURLIN-W4L15309  
(x2) | 15/16"x1 5/16"x51 1/2" (24x34x1308)



**T02** | PURLIN- W4L15239  
(2) | 1"x1 5/16"x12 3/4" (24x34x324)

# OWNER'S MANUAL - PARTS IDENTIFICATION

## Hardware Components

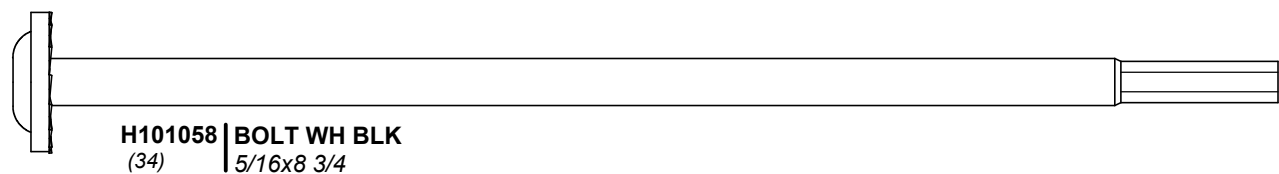
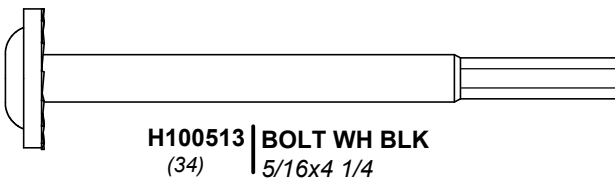
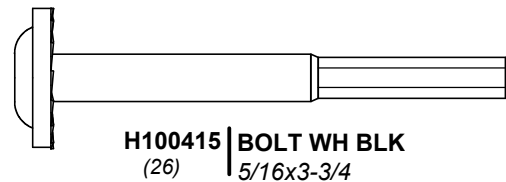
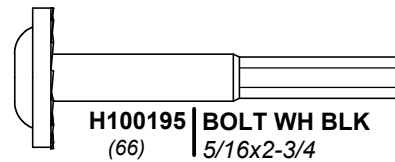
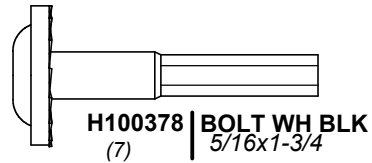
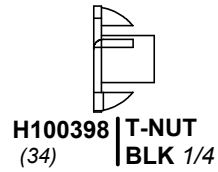
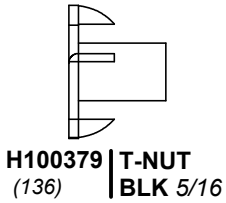
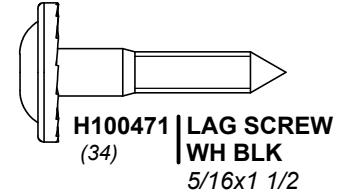
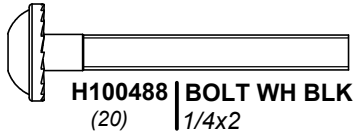
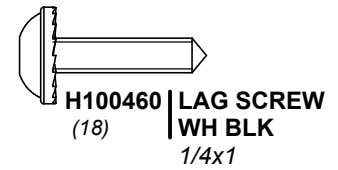
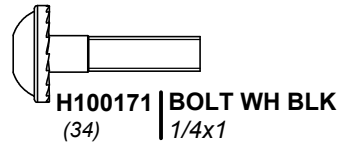
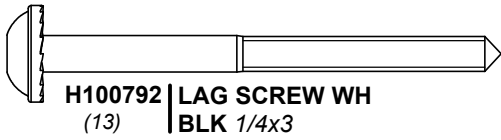

# OWNER'S MANUAL - PARTS IDENTIFICATION

## Hardware Components

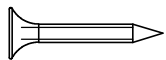

**H100385 | SCREW PFH**  
(184) | BLK 8x1

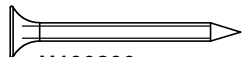

**H100200 | SCREW PFH**  
(24) | BLK 8x1 1/2

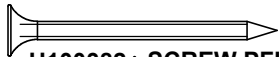

**H100382 | SCREW PFH**  
(24) | BLK 8x1 3/4



**H100391 | SCREW PFH**  
(284) | BLK 8x2

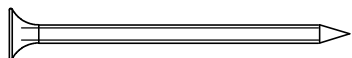

**H100483 | SCREW PFH**  
(92) | BLK 8x2 1/4

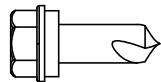

**H100759 | SCREW TAPPING**  
(62) | 1/4x1

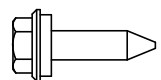

**H100833 | SCREW WOODGRIP**  
(312) | 10x3/4

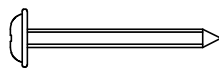

**H100536 | SCREW PWH**  
(44) | BLK 8x1 1/4



**H100392 | SCREW PWH**  
(17) | BLK 8x3/4

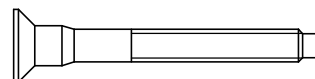

**H101030 | SCREW CONFIRMAT BLK**  
(124) | 7x2

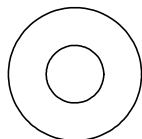

**H100770 | WASHER FLAT**  
(26) | BLK 5/16



**H101034 | WEATHER PROOF WASHER**  
(4)



**H100479 | NUT LOCK BLK**  
(26) | 5/16

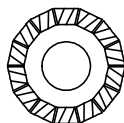

**H100198 | WASHER LOCK EXT BLK**  
(162) | 8x19

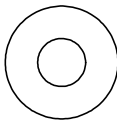

**H100630 | WASHER FLAT**  
(37) | BLK 8x19

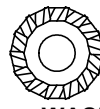

**H100405 | WASHER LOCK EXT BLK**  
(9) | 6x15



**H100653 | NUT LOCK BLK**  
(20) | 1/4

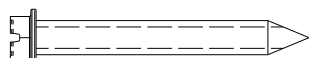

**H100120 | SCREW CONCRETE ANCHOR**  
(18) | 1/4x2

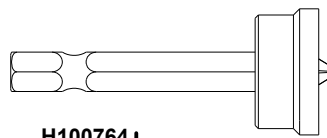

**H100764 | SCREW SETTER**  
(1)

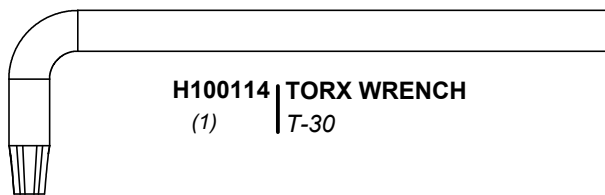

**H100114 | TORX WRENCH**  
(1) | T-30

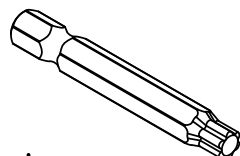

**H100147 | T-30 TORX BIT**  
(1)

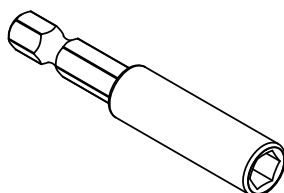

**H101100 | BIT ADAPTOR**  
(1)

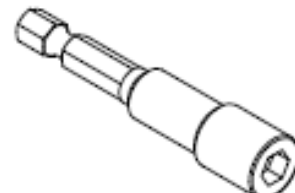

**H101106 | HEX DRIVER**  
(x1) | 5/16

# OWNER'S MANUAL - PARTS IDENTIFICATION

## Accessory Components (Not to Scale)

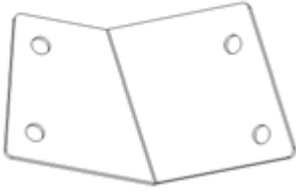

**A4M01191** | PANEL BRACKET  
(2)

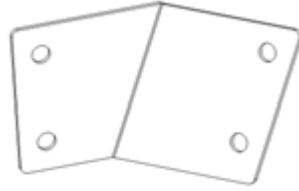

**A4M01193** | PANEL BRACKET  
(2)

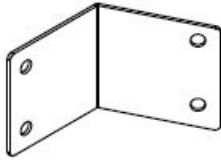

**A4M01238** | PANEL BRACKET  
(2)

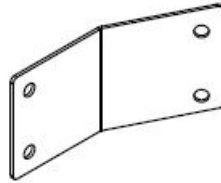

**A4M01239** | PANEL BRACKET  
(2)



**A4M01752** | RAFTER CLIP  
(18)

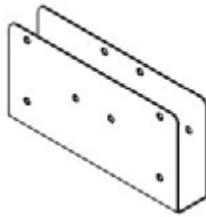

**A4M01237** | ROOF  
SUPPORT  
SPLICE CLIP  
(12)

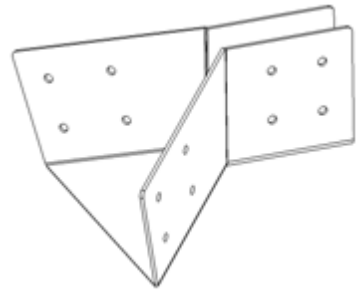

**A4M01184** | PANEL SUPPORT BRACKET  
(2)



**A4M01794** | STEEL POST PLATE  
(8)



**A4M01793** | STEEL POST  
ANCHOR  
PLATE  
(8)

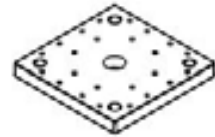

**A6P00308** | 6x6 POST FOOT  
(4)



**A4M02158** | BYD ID TAG  
(SMALL)  
WITHOUT  
AGES  
(1)



**A4M01185** | CORNER BRACKET  
(4)

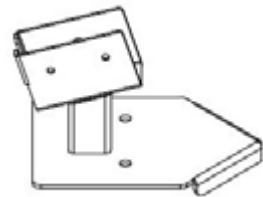

**A4M01234** | POST CLIP  
(4)

# OWNER'S MANUAL - PARTS IDENTIFICATION

## Accessory Components (Not to Scale)

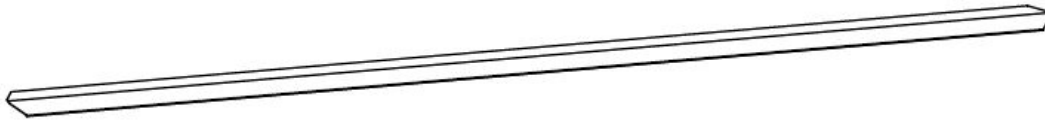

A4M02826 | CORNER RIDGE CAP LONG  
(4)



A4M02867 | RIDGE CAP SPLICE  
ASSEMBLY  
(4)

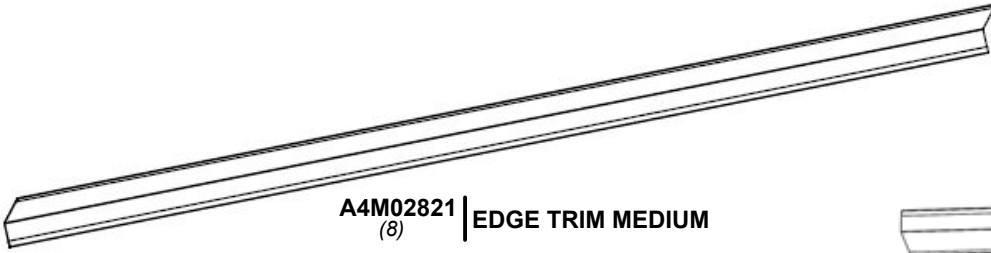

A4M02821 | EDGE TRIM MEDIUM  
(8)



A4M02869 | EDGE TRIM SHORT  
(2)

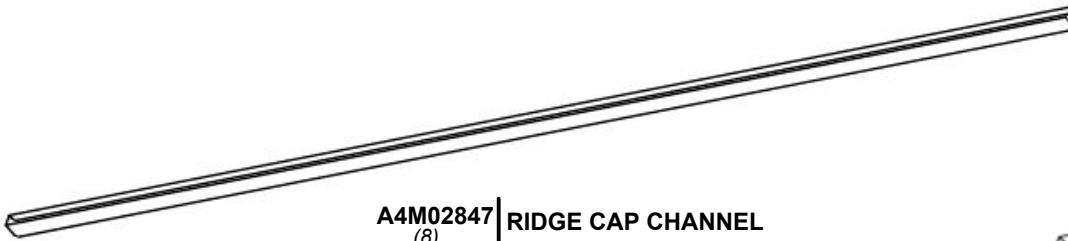

A4M02847 | RIDGE CAP CHANNEL  
(8)



A4M02850 | RIDGE CAP CHANNEL  
SHORT  
(8)

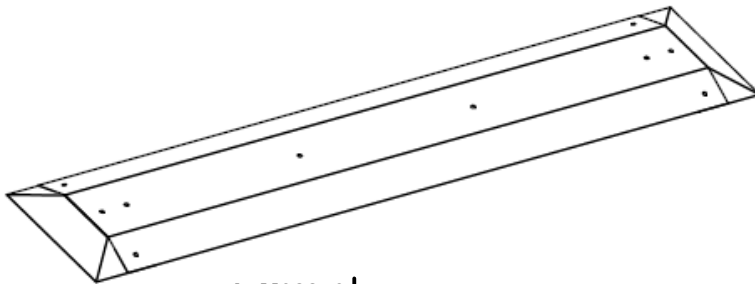

A4M02870 | RIDGE PEAK CAP  
(1)



A4M01205 | METAL SPACER  
(4)

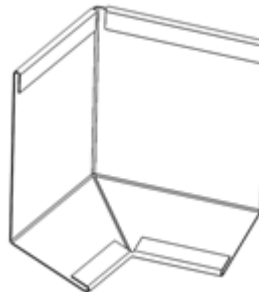

A4M02825 | EDGE TRIM CORNER SPLICE  
(4)

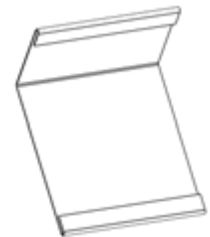

A4M02822 | EDGE TRIM SPLICE  
(6)

# OWNER'S MANUAL - PARTS IDENTIFICATION

## Accessory Components (Not to Scale)

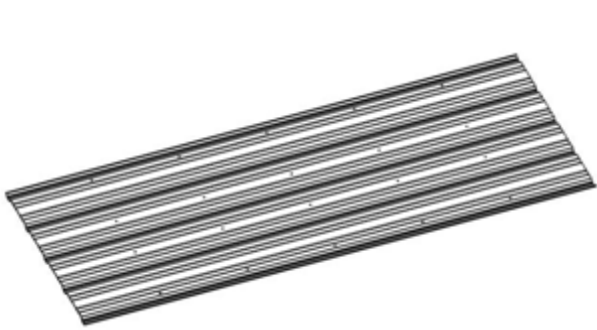

**A4M02818** | 29 GA STEEL SHEETING  
(2)

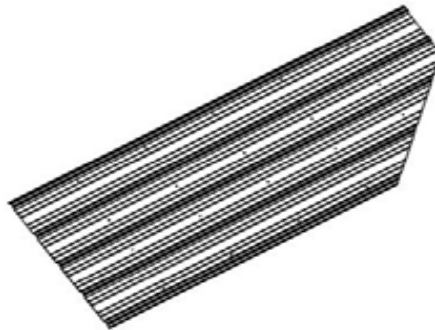

**A4M02812-1** | 29 GA STEEL SHEETING  
(2)



**A4M02812-2** | 29 GA STEEL SHEETING  
(2)

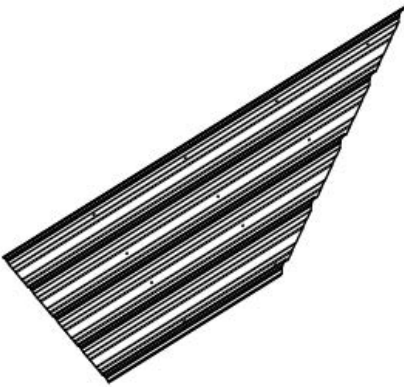

**A4M02813-1** | 29 GA STEEL SHEETING  
(2)



**A4M02813-2** | 29 GA STEEL SHEETING  
(2)



**A4M02814-1** | 29 GA STEEL SHEETING  
(2)

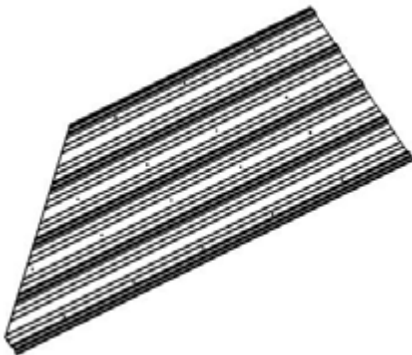

**A4M02814-2** | 29 GA STEEL SHEETING  
(2)



**A4M02815-1** | 29 GA STEEL SHEETING  
(2)



**A4M02815-2** | 29 GA STEEL SHEETING  
(2)

# OWNER'S MANUAL - PARTS IDENTIFICATION

## Accessory Components (Not to Scale)



**A4M02816-1** | 29 GA STEEL SHEETING  
(2)

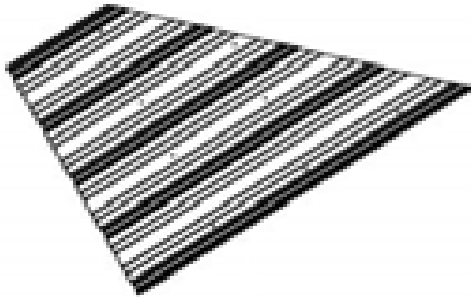

**A4M02816-2** | 29 GA STEEL SHEETING  
(2)

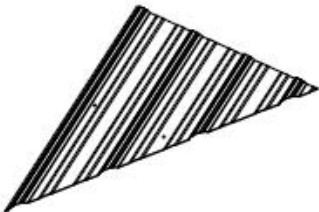

**A4M02817-1** | 29 GA STEEL SHEETING  
(2)

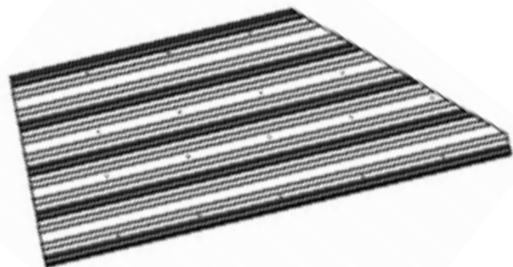

**A4M02817-2** | 29 GA STEEL SHEETING  
(2)

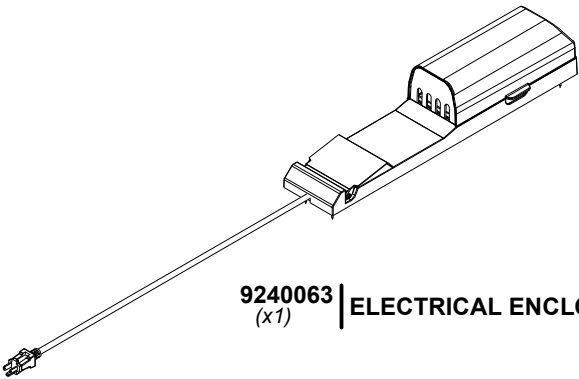

**9240063** | ELECTRICAL ENCLOSURE  
(x1)

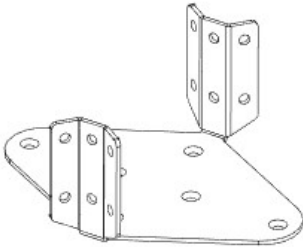

**A4M02501** | FAN MOUNTING BRACKET  
(x1)

# PRE-ASSEMBLY STEP 1 - SORTING PARTS

It is critical for ease of assembly that you take the time to sort and organize the wood and hardware.

---

## WOOD PARTS:

- Organize wood parts by the three-digit, alpha-numeric number stamped on each board (ex. P01).
- If there are multiple boards with the same stamped number, stack those pieces together.
- Stamps can be found on the flat surface of the boards or on the end of the boards.
- Allow yourself plenty of room - the wood pieces can take up a significant amount of space.

**NOTE: CARTONS ARE NOT ORGANIZED BY BOARD NUMBER.**



## HARDWARE PARTS:

- We recommend that you have a separate table to organize the hardware.
- Hardware bags are printed with a seven-digit, alpha-numeric part number.
- You can organize your hardware by part number or group by hardware type (i.e. bolts, nuts, etc.).
- During assembly you only need to reference the last four digits of the number.

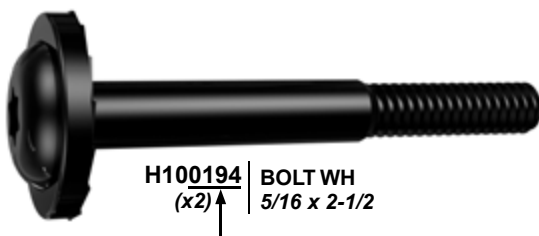

H100194 | BOLT WH  
(x2) ↑ 5/16 x 2-1/2

# PRE-ASSEMBLY STEP 2 - TOOLS REQUIRED



Cordless Drill or Electric Drill



Drill Attachments:  
Phillips Head



1/8", 3/16", 3/8" & 7/16" Drill Bits



Phillips Screw Driver



Tape Measure



Claw Hammer



Open End Wrenches 1/2" & 7/16"



3/8" Drive Ratchet, 1/2" & 7/16" STD Sockets, 1/2" & 7/16" Deep Sockets



3/8 & 5/16" Nut Drivers

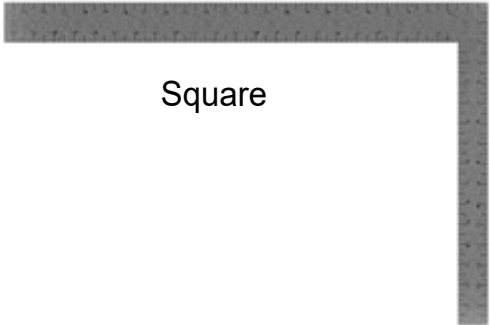

Square



Level 24"



Rubber Mallet - Optional



A6P00460 | QUICK RELEASE BAR CLAMP  
(2)

# PRE-ASSEMBLY STEP 3 - CHOOSE YOUR ASSEMBLY METHOD

There are several types of assembly instructions available to you.

1. Printed Assembly Manual included with your set
2. BILT APP - 3D interactive instructions
3. Combination of the Printed Manual and BILT APP (Note: Step numbers can differ between the two methods)



The graphic is a rectangular advertisement for the BILT app. At the top left is the BILT logo, which consists of a stylized hexagonal icon with a dot inside, followed by the word "BILT." in a bold, sans-serif font. To the right of the logo is a large QR code. Below the logo and QR code, the text "Scan for easy 3D instructions" is written in a large, bold, black font. Underneath this, in a smaller font, it says "Download the BILT app before you begin". To the right of this text are two buttons: "Download on the App Store" with the Apple logo and "GET IT ON Google Play" with the Google Play logo. At the bottom of the graphic is a smartphone screen displaying a 3D assembly instruction. The screen shows a grey 3D model of a structure with a horizontal beam and a triangular support. The interface includes a "Part(s) Needed" label at the top left, a close button (X) at the top right, a list of parts at the bottom left, and navigation arrows at the bottom right.

# STEP 1 - 12FT POST ASSEMBLY

Qty	PART NUMBER	DESCRIPTION
8	H100200	SCREW PFH 8x1 1/2 BLK

**P01** | POST - W2A03202  
 (1) | 6"x6"x89 1/2" (152x152x2274)

**P02** | POST - W2A03203  
 (1) | 6"x6"x89 1/2" (152x152x2274)

**A6P00308** | 6x6 POST FOOT  
 (2)

**TIP:**  
 FOR EASE OF ASSEMBLY, SAW HORSES ARE  
 RECOMMENDED FOR STEPS 1 THROUGH 3

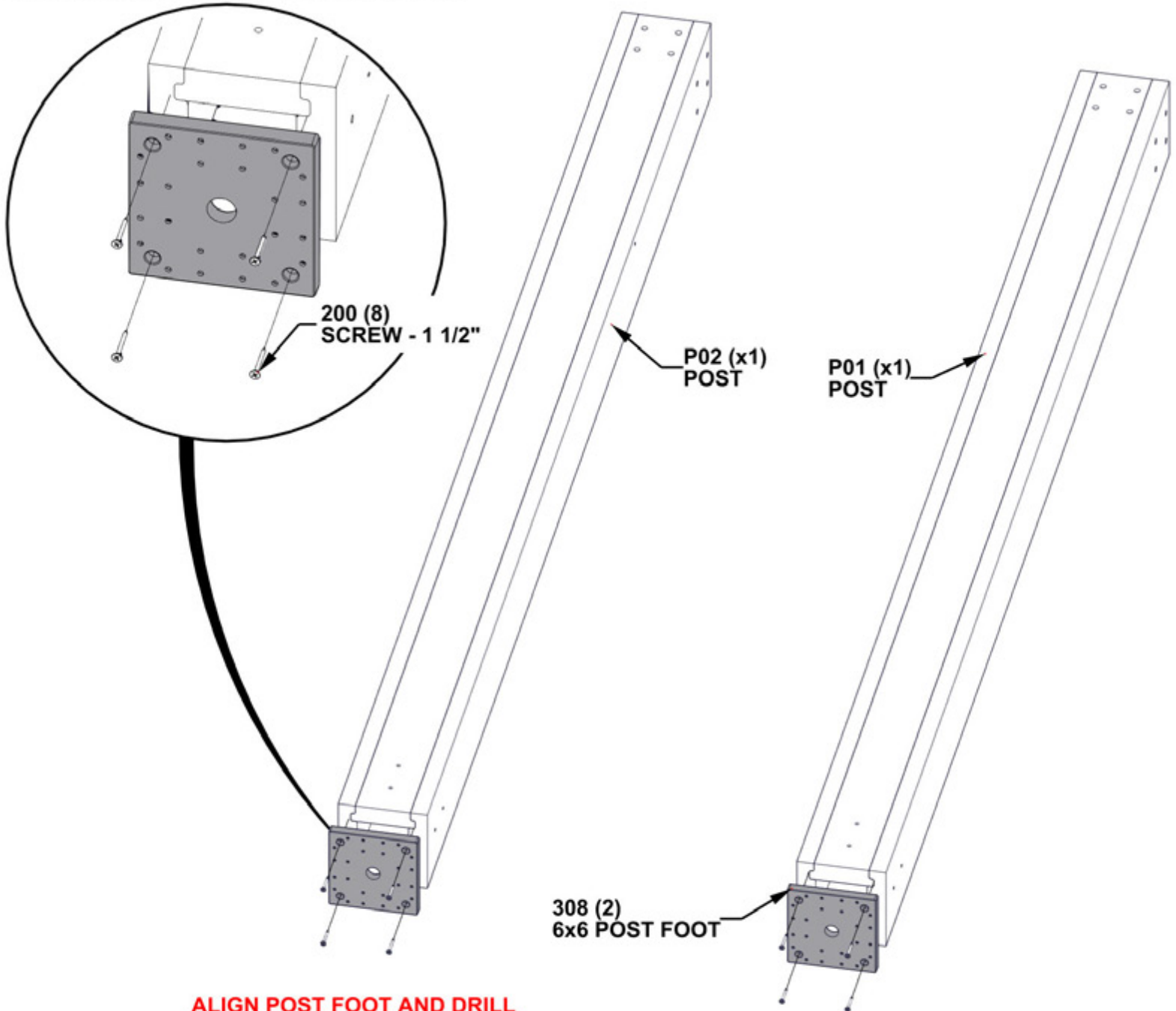

**ALIGN POST FOOT AND DRILL  
 1/8" PILOT HOLES FOR THE  
 ATTACHMENT OF HARDWARE**

# STEP 2 - 12FT BEAM ASSEMBLY

Qty	PART NUMBER	DESCRIPTION
8	H100195	BOLT WH 5/16x2 3/4 BLK
8	H100198	WASHER LOCK EXT 8X19
8	H100379	TNUT-5/16" BLK



**D05** | BEAM - W4L15240  
 (1) | 1 3/8"x5 1/4"x45 1/4" (36x134x1150)

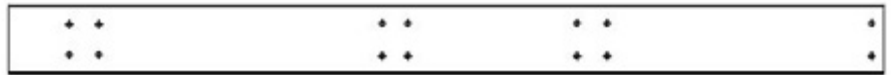

**D06** | BEAM - W4L15241  
 (2) | 1 3/8"x5 1/4"x67 13/16" (36x134x1723)

## INSERT T-NUTS FIRST

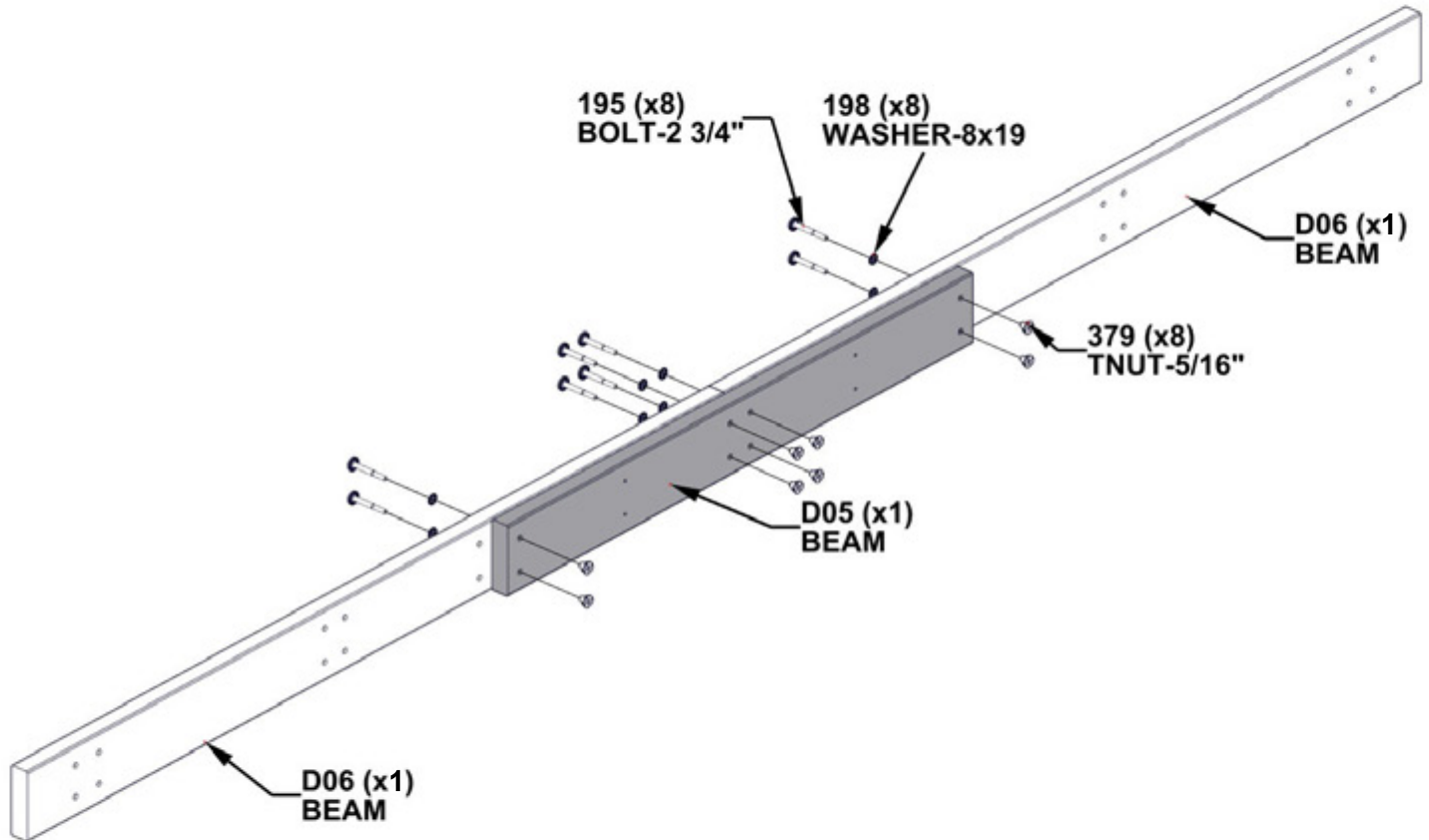

# STEP 3 - 12FT BEAM ASSEMBLY

Qty	PART NUMBER	DESCRIPTION
4	H100195	BOLT WH 5/16x2 3/4 BLK
4	H100198	WASHER LOCK EXT 8X19
4	H100379	TNUT-5/16" BLK



**D01** | BEAM-W4L15192  
 (2) 1 3/8"x5 1/4"x45 3/16" (36x134x1148)

## INSERT T-NUTS FIRST

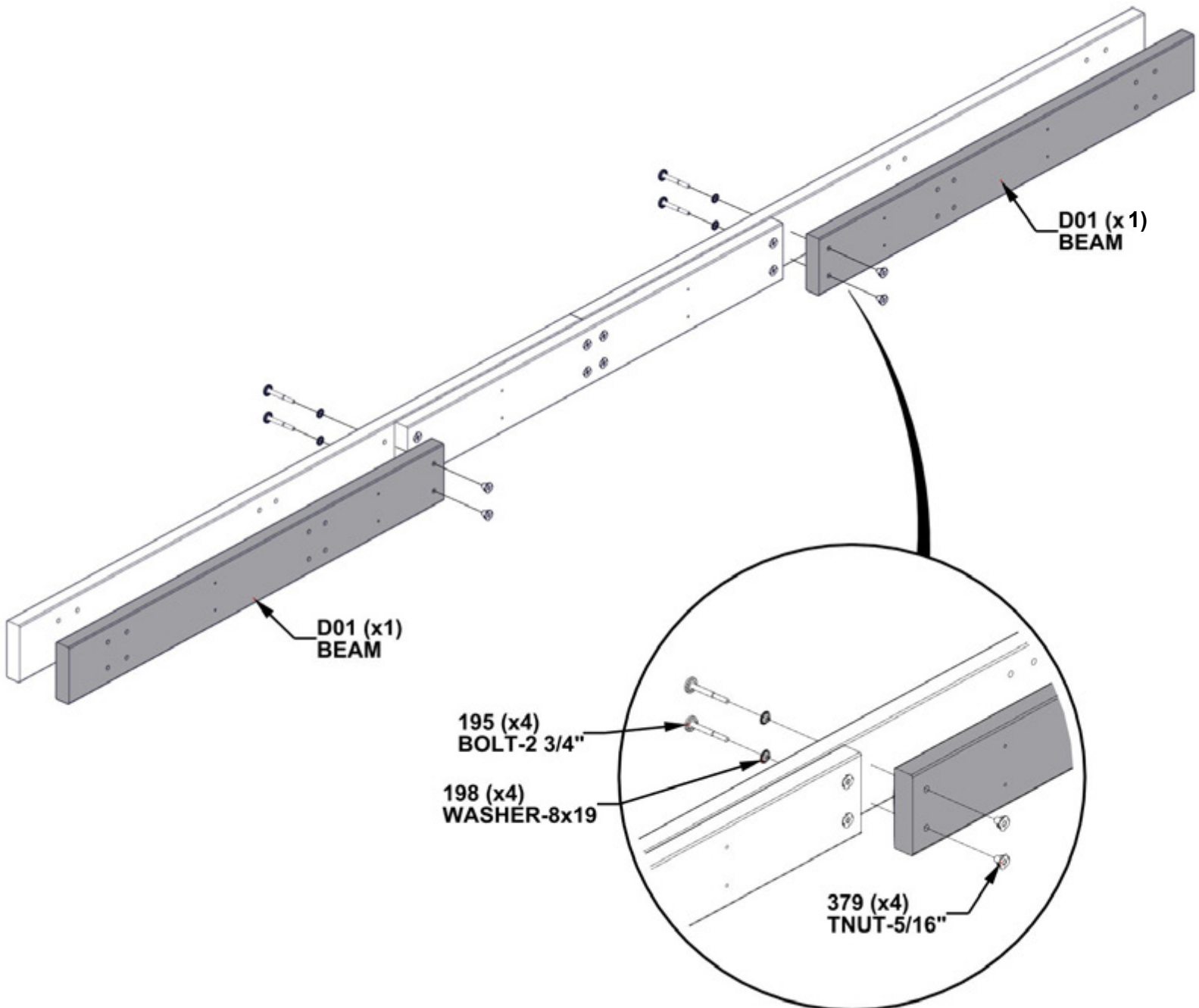

# STEP 4 - 12FT BEAM ASSEMBLY

Qty	PART NUMBER	DESCRIPTION
12	H100483	SCREW PFH 8x2 1/4 BLK



**12 FT BEAM ASSEMBLY  
FROM PREVIOUS STEPS**

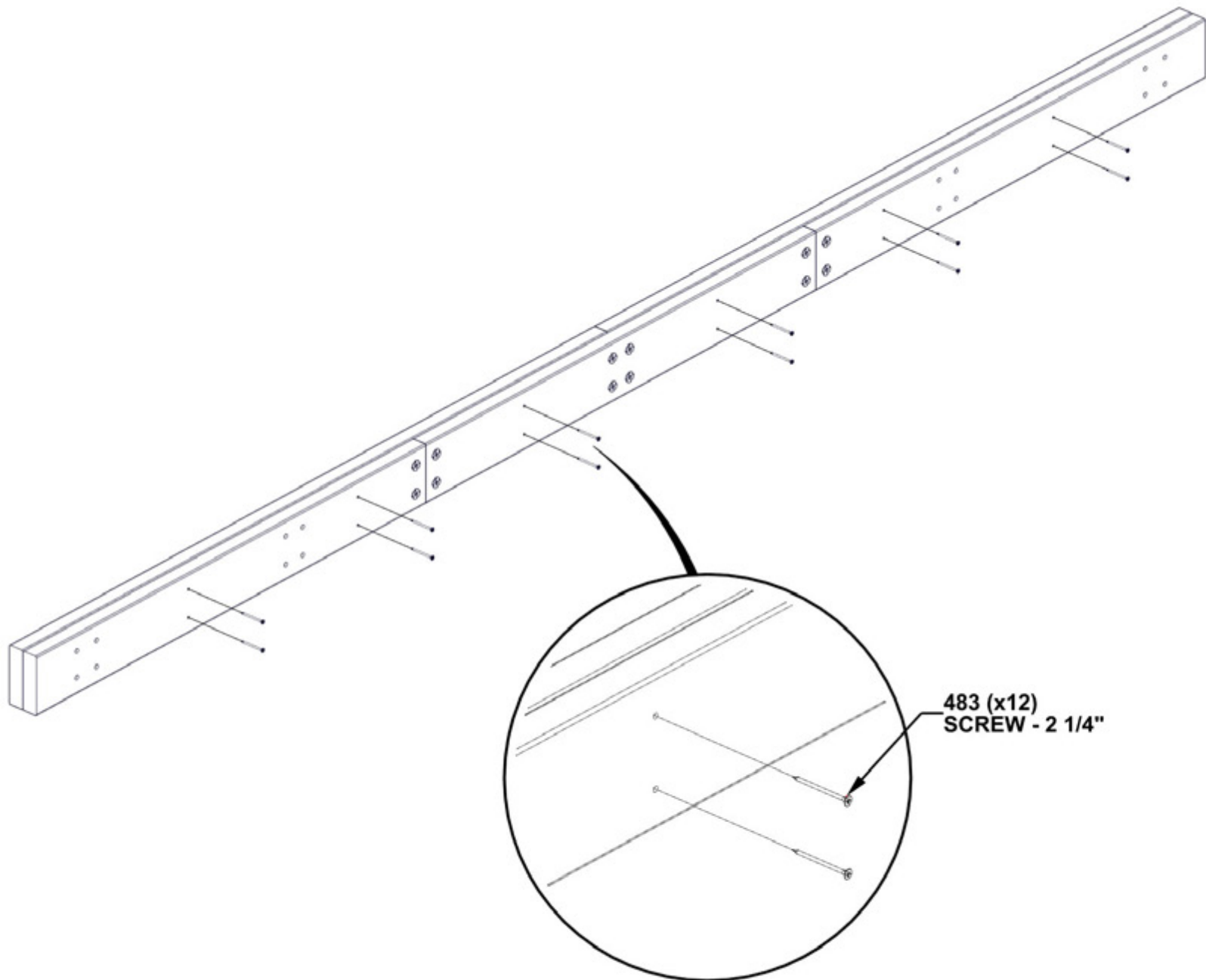

# STEP 5 - 12FT BEAM ASSEMBLY

Qty	PART NUMBER	DESCRIPTION
8	H100198	WASHER LOCK EXT 8X19
8	H100379	TNUT-5/16" BLK
8	H101058	BOLT WH 5/16x8 3/4 BLK



12FT BEAM ASSEMBLY FROM PREVIOUS STEPS

## INSERT T-NUTS FIRST

### TIPS:

SAW DUST CAN BE LEFT BEHIND IN BOLT HOLES. IF YOU HAVE TROUBLE WITH BOLT ENGAGING, USE A LONG SCREWDRIVER TO REMOVE THE DEBRIS.

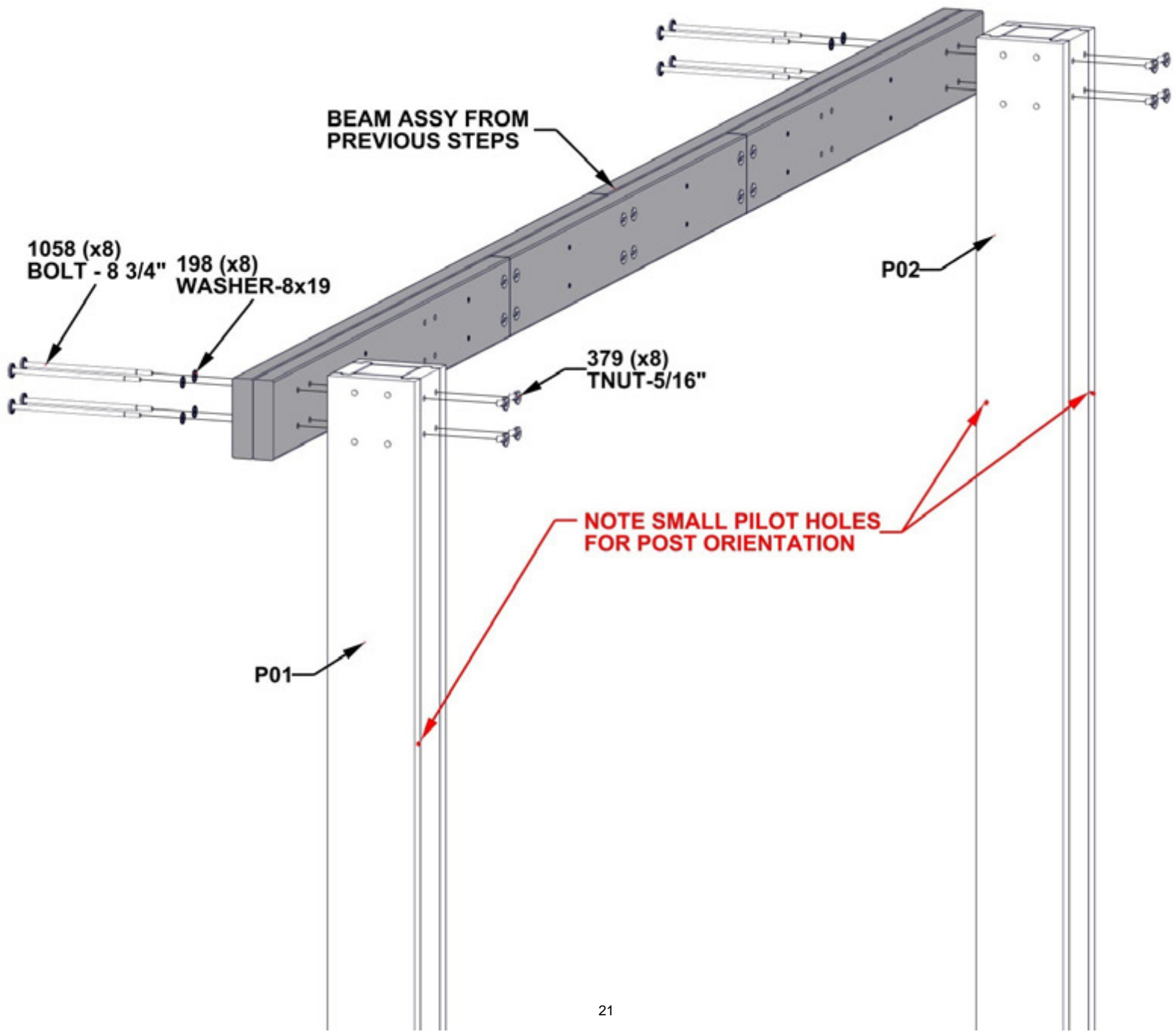

# STEP 6 - 12FT BEAM ASSEMBLY

Qty	PART NUMBER	DESCRIPTION
8	H100198	WASHER LOCK EXT 8X19
8	H100379	TNUT-5/16" BLK
2	H100405	WASHER LOCK EXT 6X15
8	H100513	BOLT WH 5/16x4 1/4 BLK
2	H100792	LAG SCREW WH 1/4x3 BLK



**C01** | CORBEL- W2A03198  
 (2) | 1 7/16"x6 7/16"x35 1/8" (36x163x893)

## INSERT T-NUTS FIRST

**TIPS:**  
 INSERT BOLTS FIRST FOLLOWED BY LAG SCREWS.  
 TO AVOID WOOD SPLITTING, MAKE SURE LAG SCREWS GO INTO PILOT HOLES.

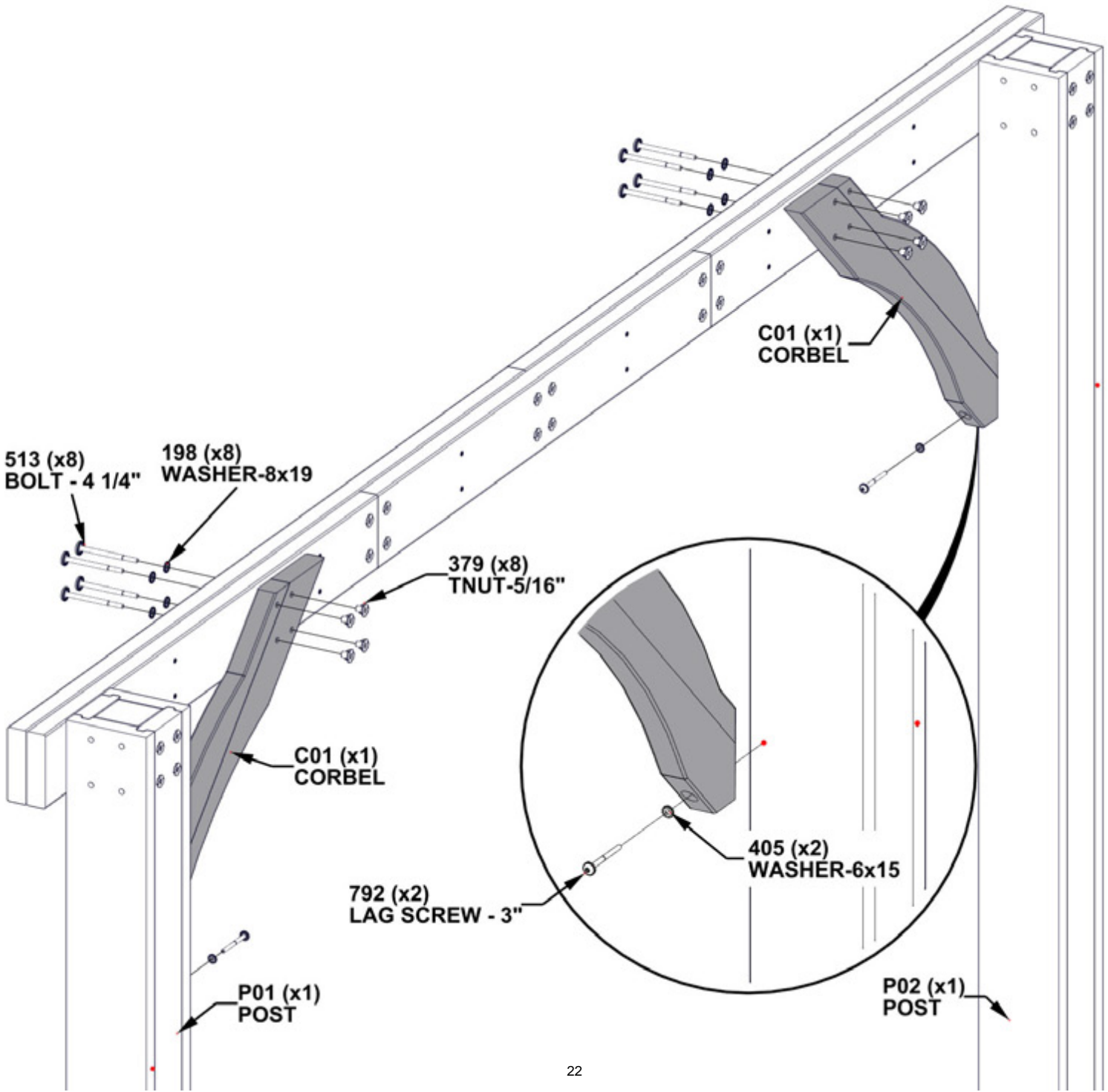

**SET 12FT ASSEMBLY TO THE SIDE  
AND REPEAT STEPS 1 THROUGH 6.**

# STEP 7 - 16FT BEAM ASSEMBLY

Qty	PART NUMBER	DESCRIPTION
12	H100195	BOLT WH 5/16x2 3/4 BLK
12	H100198	WASHER LOCK EXT 8X19 BLK
12	H100379	TNUT-5/16" BLK



**D03** BEAM - W4L15283  
 (1) 1 3/8"x5 1/4"x59 15/16" (36x134x1522)



**D02** BEAM - W4L15284  
 (2) 1 3/8"x5 1/4"x59 1/16" (36x134x2261)

## INSERT T-NUTS FIRST

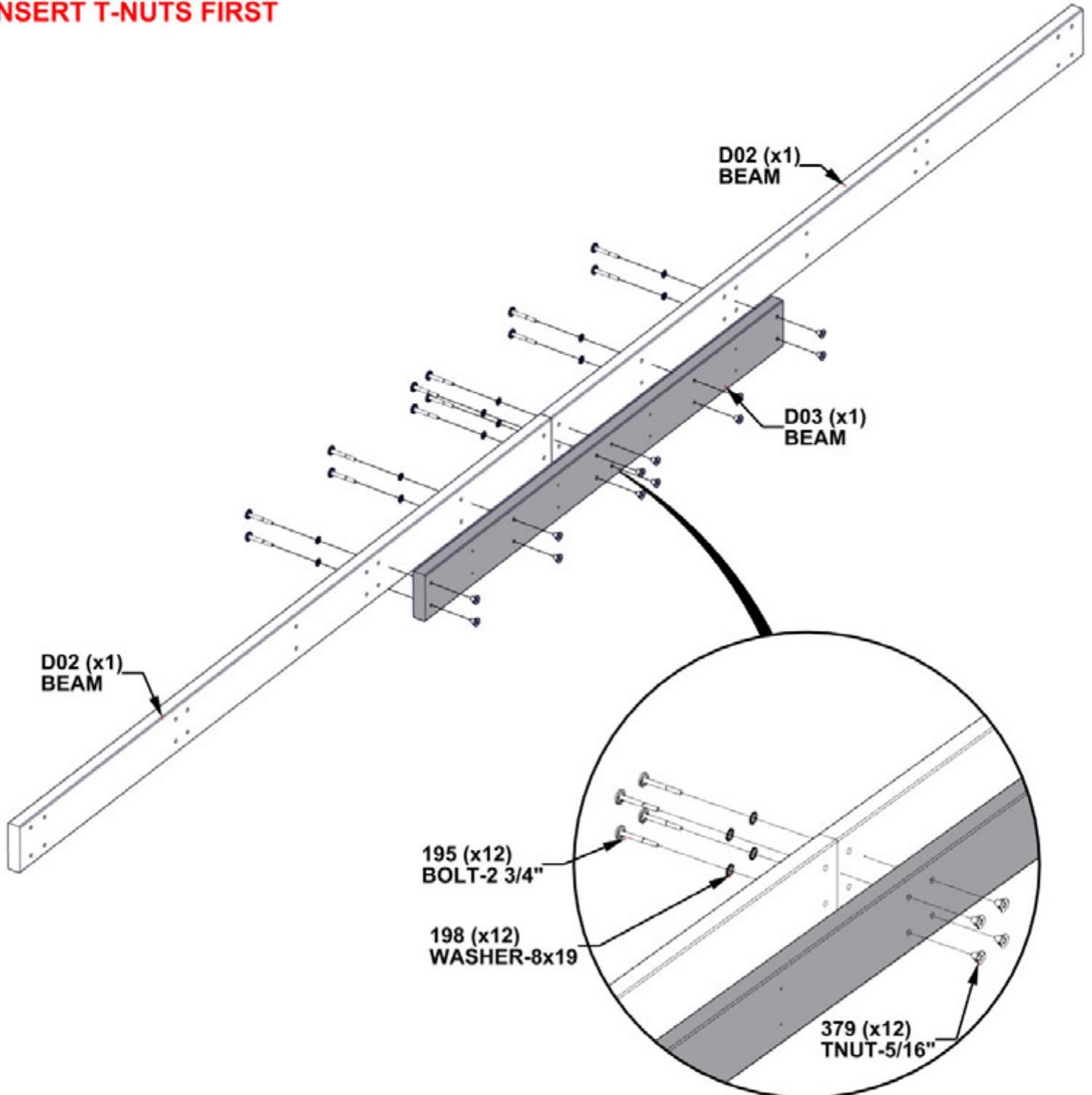

# STEP 8 - 16FT BEAM ASSEMBLY

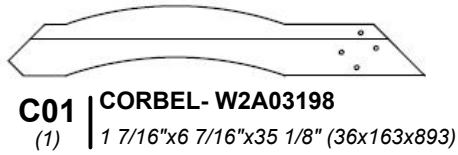

Qty	PART NUMBER	DESCRIPTION
8	H100195	BOLT WH 5/16x2 3/4 BLK
16	H100198	WASHER LOCK EXT 8X19 BLK
16	H100379	TNUT-5/16" BLK
8	H100513	BOLT WH 5/16x4 1/4 BLK

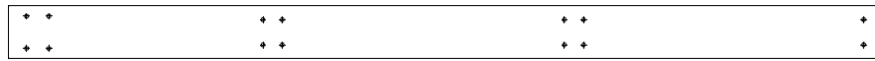

**INSERT T-NUTS FIRST**

**HAND TIGHTEN ONLY**

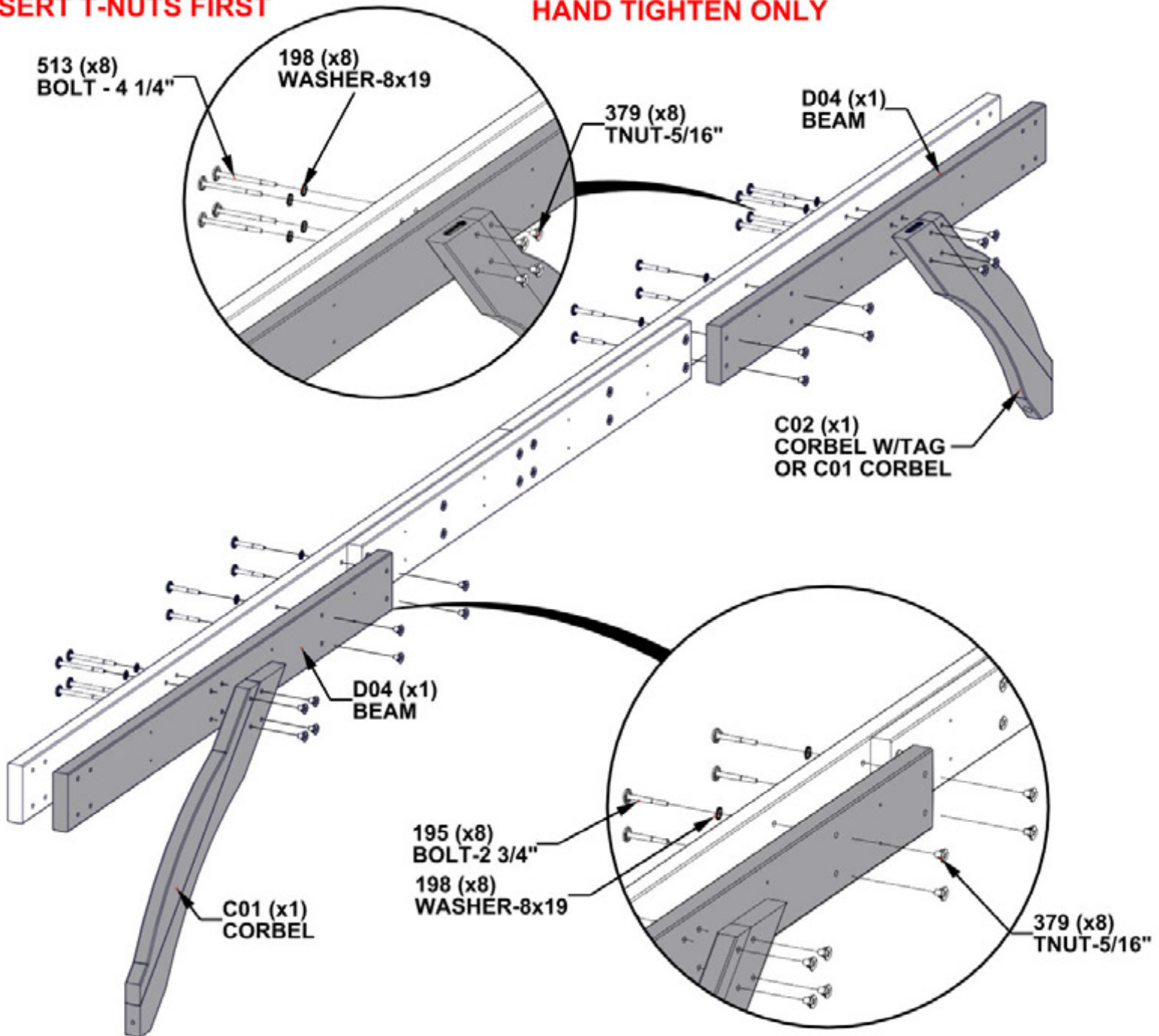

# STEP 9 - 16FT BEAM ASSEMBLY

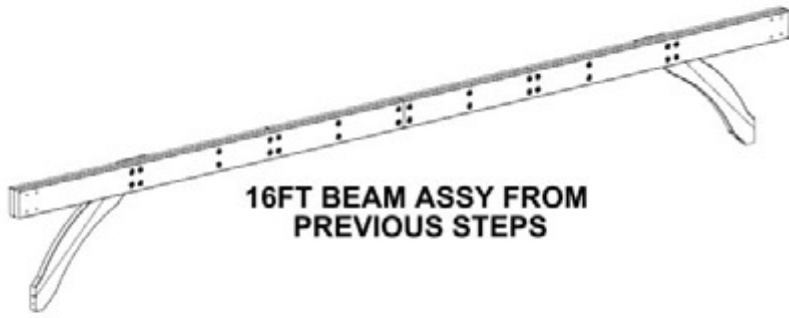

Qty	PART NUMBER	DESCRIPTION
20	H100483	SCREW PFH 8x2 1/4 BLK

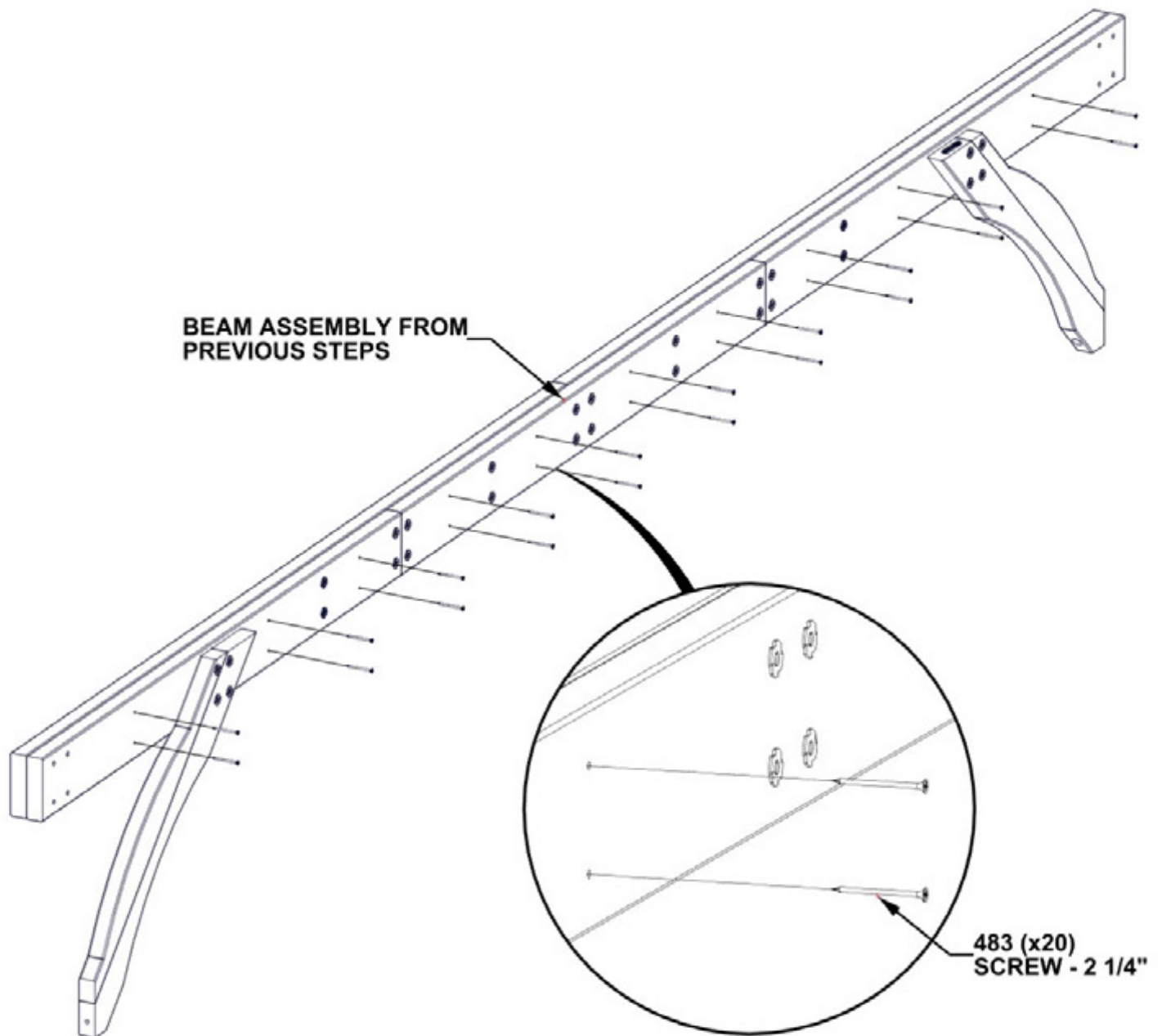

# STEP 10A - 16FT BEAM ASSEMBLY

Qty	PART NUMBER	DESCRIPTION
8	H100198	WASHER LOCK EXT 8X19 BLK
8	H100379	TNUT-5/16" BLK
2	H100405	WASHER LOCK EXT 6X15 BLK
2	H100792	LAG SCREW WH 1/4x3 BLK
8	H101058	BOLT WH 5/16x8 3/4 BLK

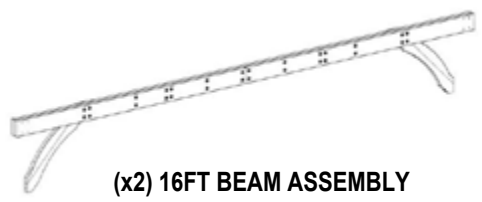
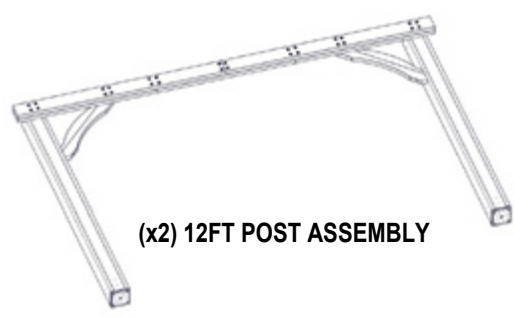

**TIPS:**  
 THREE PEOPLE ARE HELPFUL FOR THIS STEP.  
 MOVE THE 12FT POST ASSEMBLIES TO THEIR FINAL LOCATIONS WITH SOMEONE HOLDING EACH ASSEMBLY UPRIGHT.

**HAND TIGHTEN ONLY  
 INSERT T-NUTS FIRST**

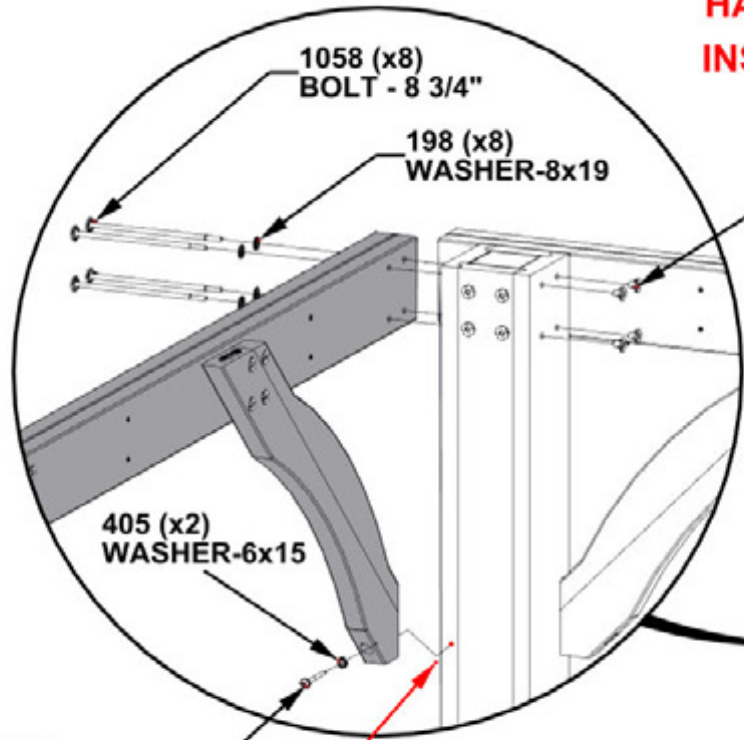

**TO AVOID SPLITTING, LAG SCREWS MUST GO INTO PILOT HOLES**

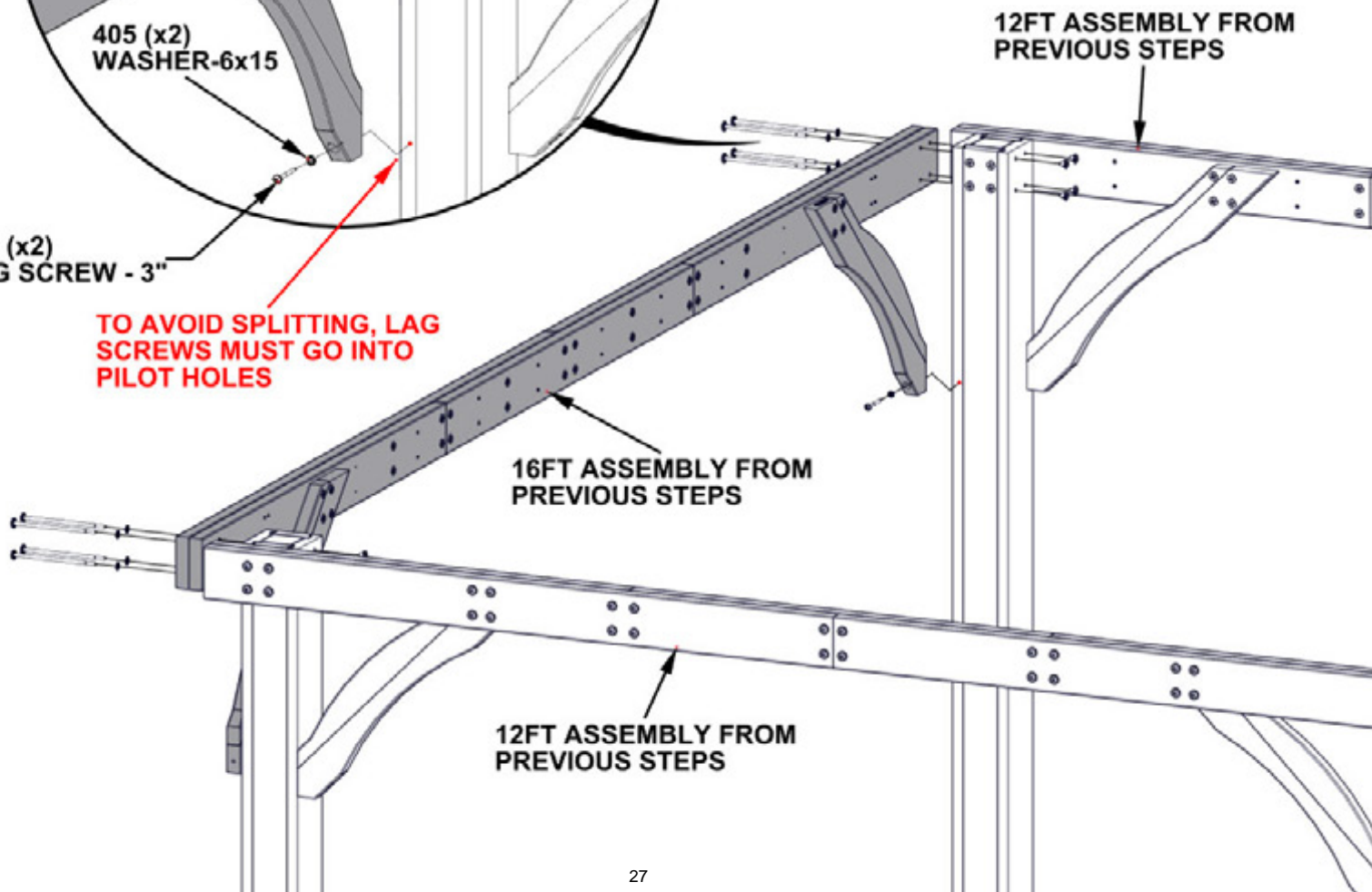

# STEP 10B - 16FT BEAM ASSEMBLY

Qty	PART NUMBER	DESCRIPTION
12	H100483	SCREW PFH 8x2 1/4 BLK



**G01** COVER BOARD - W4L15313  
 (1) 1"x5 1/4"x89 1/2" (24x134x2274)

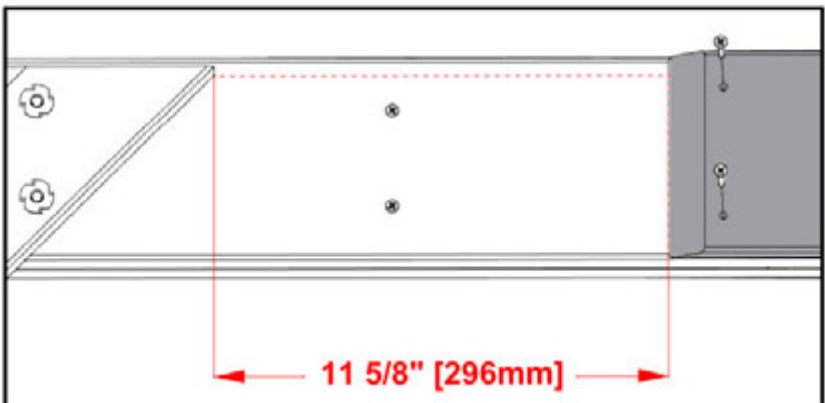

**FOR BOARD PLACEMENT, MEASURE AS SHOWN FROM CORNER OF CORBEL. USE PILOT HOLES TO ATTACH BOARD.**

**16FT ASSEMBLY FROM PREVIOUS STEPS**

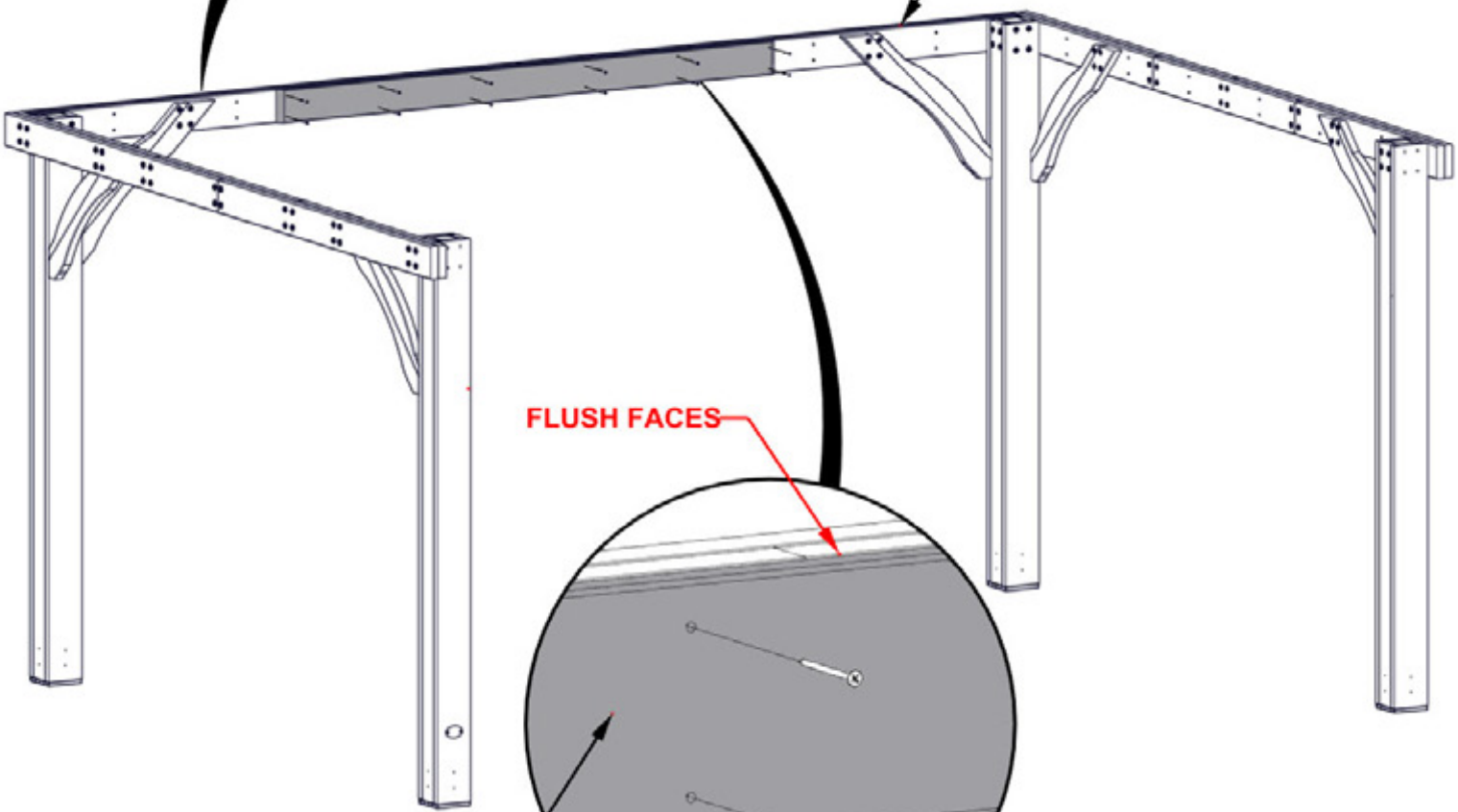

**FLUSH FACES**

**G01 (x1)  
COVER BOARD**

**483 (x12)  
SCREW - 2 1/4"**

**REPEAT STEPS 7 THROUGH 10 FOR OPPOSITE  
SIDE 16FT BEAM ASSEMBLY**

# STEP 11

**CRITICAL: SQUARE UNIT BEFORE PROCEEDING TO NEXT STEPS.  
ONCE SQUARE, TIGHTEN ALL HARDWARE**

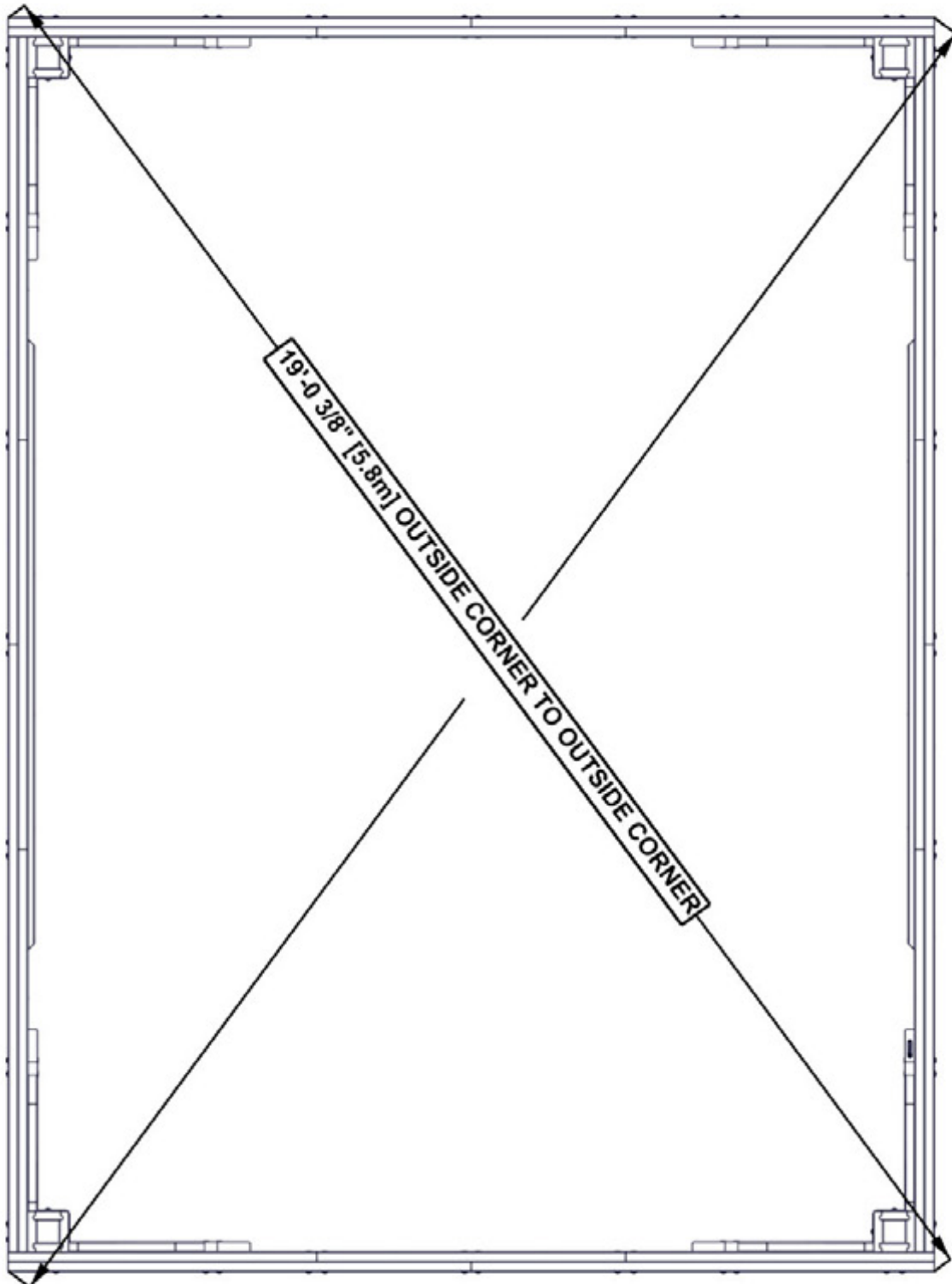

TOP VIEW

# STEP 12 - ROOF SUPPORT ASSEMBLY

Qty	PART NUMBER	DESCRIPTION
16	H100460	LAG SCREW WH 1/4x1 BLK



A4M01234  
(4) POST CLIP

**DO NOT OVERTIGHTEN**  
**REPEAT ON ALL FOUR POST**

460 (x4)  
LAG SCREW - 1"

1234(x1)  
POST CLIP ASSY

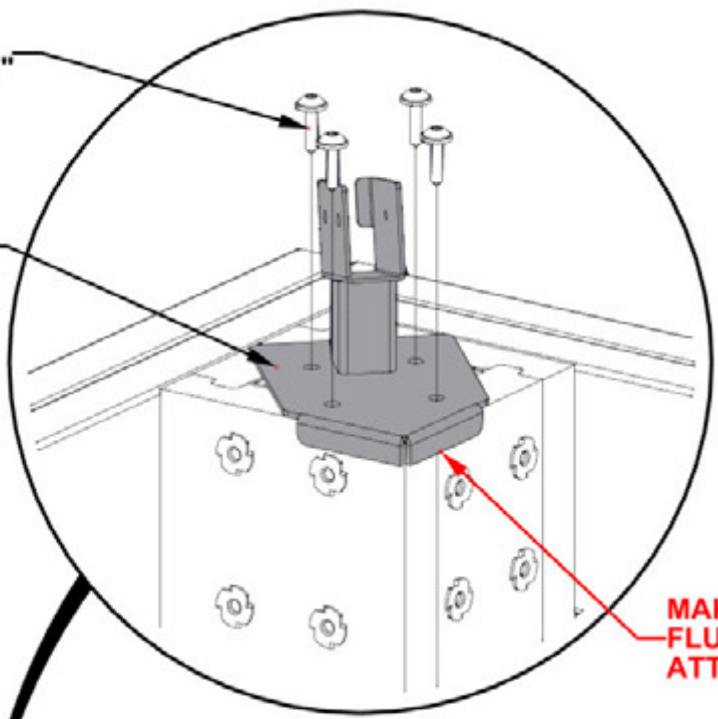

**MAKE SURE POST CLIPS ARE  
FLUSH WITH POST BEFORE  
ATTACHING LAG SCREWS.**

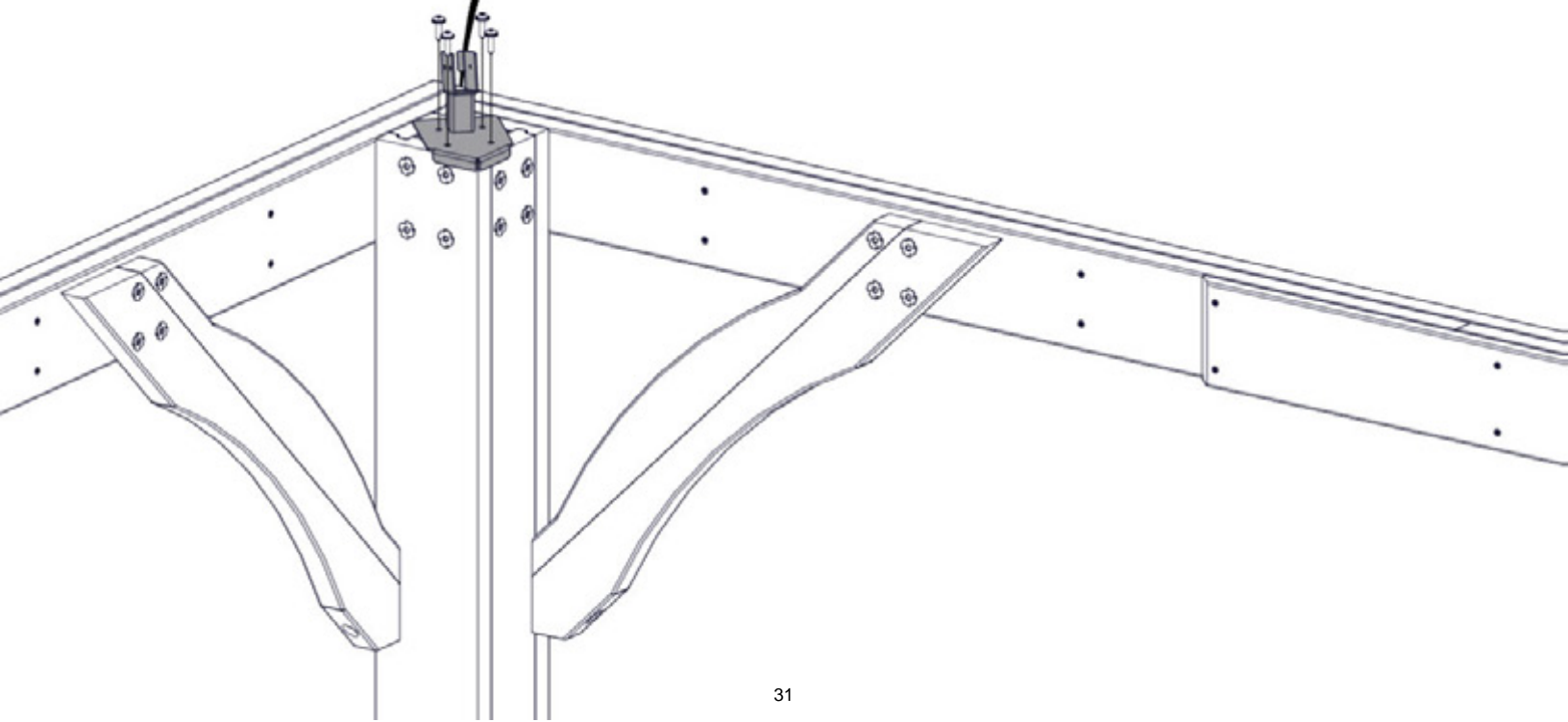

# STEP 13 - ROOF SUPPORT ASSEMBLY

Qty	PART NUMBER	DESCRIPTION
2	H100379	T-NUT 5/16 BLK
8	H100385	SCREW PFH 8x1 BLK



**H29** | ROOF SUPPORT- W4L15160  
 (1) 1"x3 3/8"x48 (24x86x1219)

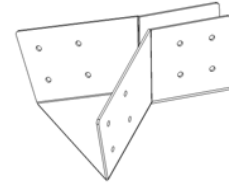

**A4M01184** | PANEL SUPPORT BRACKET  
 (2)

## INSERT T-NUTS FIRST

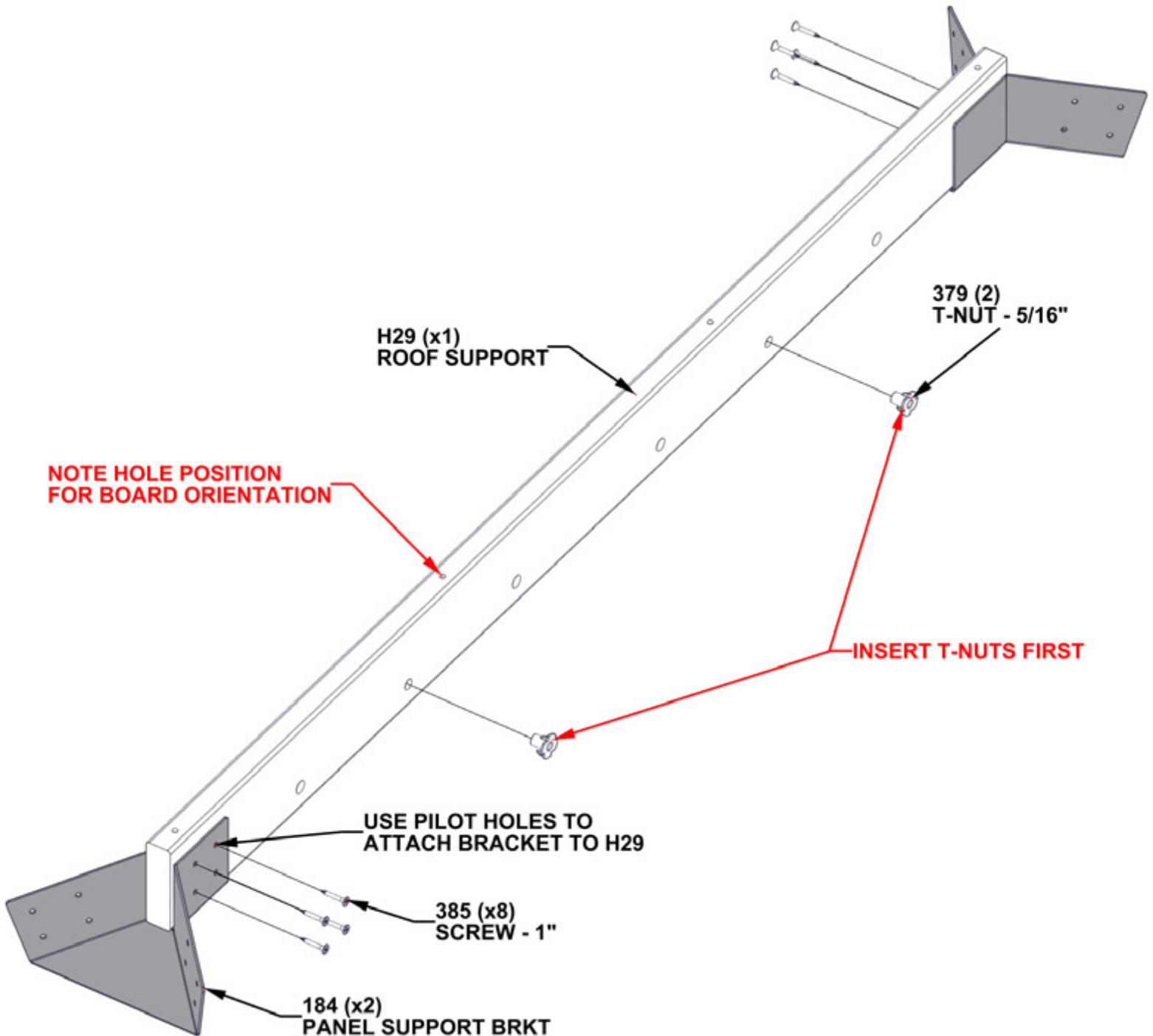

# STEP 14 - ROOF SUPPORT ASSEMBLY

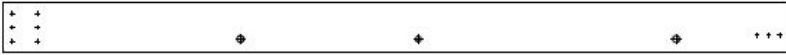

**H01** | ROOF SUPPORT- W4L15194  
 (4) | 1"x3 3/8"x54 1/8" (24x86x1374)

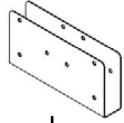

**A4M01237** | ROOF SUPPORT SPLICE CLIP  
 (4)

Qty	PART NUMBER	DESCRIPTION
4	H100379	T-NUT 5/16 BLK
48	H100385	SCREW PFH 8x1 BLK



**H04** | ROOF SUPPORT - W4L15314  
 (4) | 1"x3 3/8"x38 13/16" (24x86x986)

## INSERT T-NUTS FIRST

REPEAT FOUR TIMES

**IMPORTANT! THERE WILL BE FOUR OF THESE ASSEMBLIES. ASSEMBLE (2) WITH T-NUT ON SIDE AS SHOWN BELOW ASSEMBLE THE OTHER (2) WITH T-NUT IN SAME HOLE BUT ON OTHER SIDE OF BOARD H04**

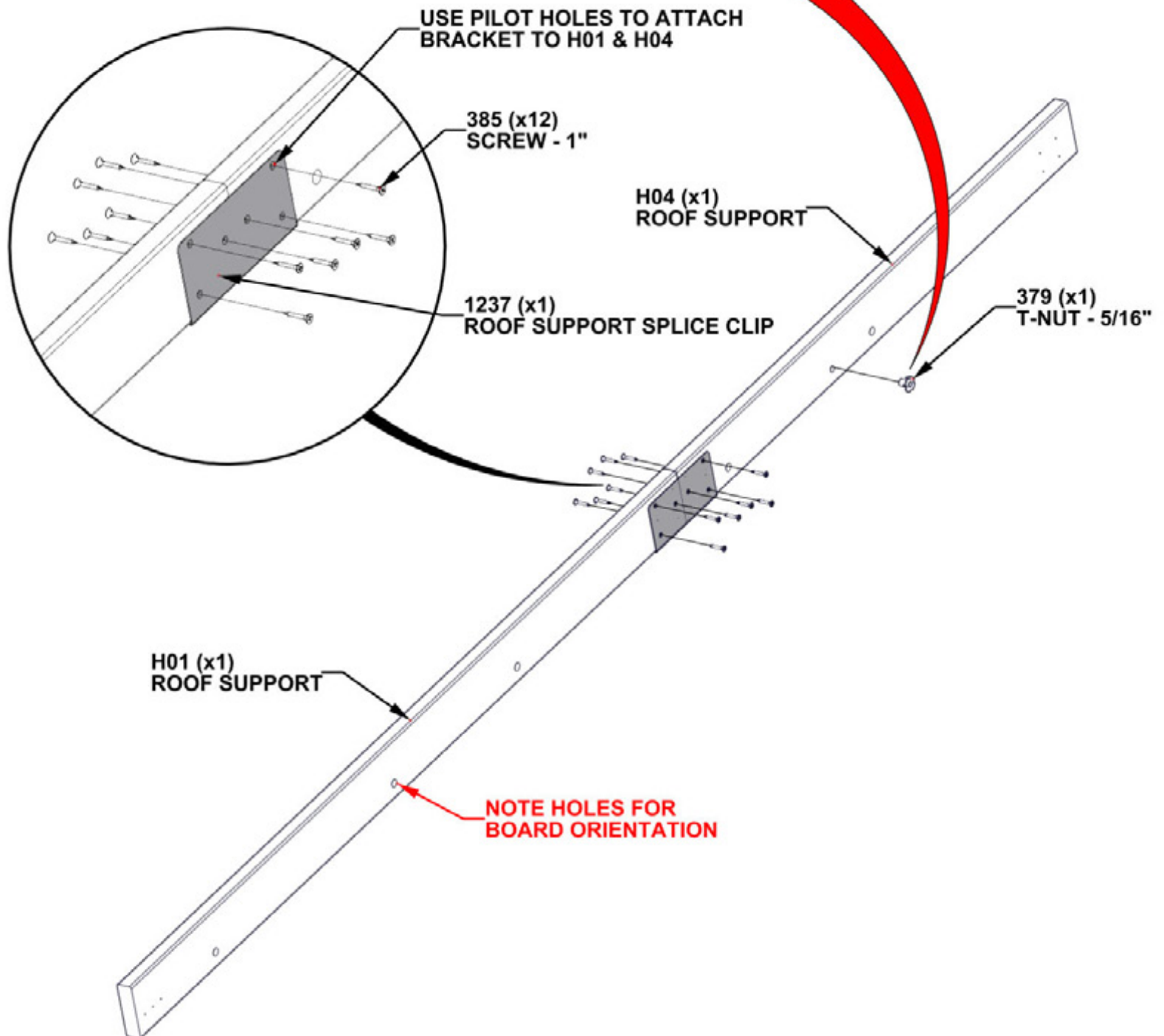

# STEP 15 - ROOF SUPPORT ASSEMBLY

Qty	PART NUMBER	DESCRIPTION
16	H100385	SCREW PFH 8x1 BLK



(x4) ROOF SUPPORT  
FROM PREVIOUS STEP

REPEAT ON OPPOSITE END OF ROOF SUPPORT BOARD

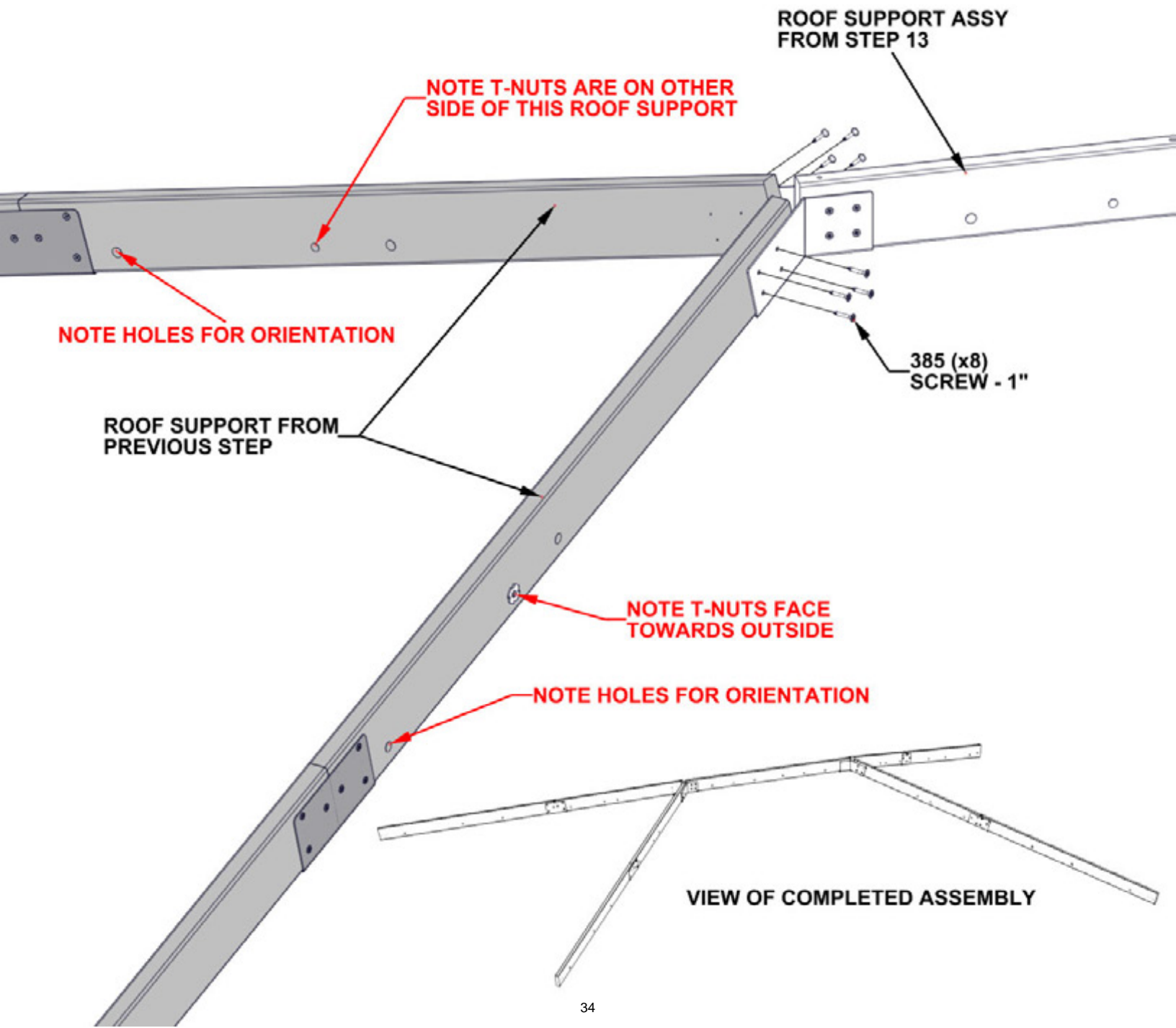

# STEP 16 - ROOF SUPPORT ASSEMBLY

Qty	PART NUMBER	DESCRIPTION
4	H100792	LAG SCREW WH 1/4x3 BLK
4	H101034	WEATHER PROOFING WASHER

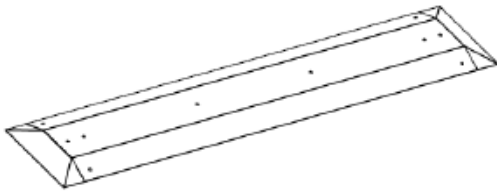

A4M02870 | RIDGE PEAK CAP  
(1)



A4M01205 | METAL SPACER  
(4)

**TIPS:**  
REMOVE PROTECTIVE BLUE FILM BEFORE ASSEMBLY

**WARNING: GLOVES ARE RECOMMENDED WHEN HANDLING STEEL ROOF PIECES**

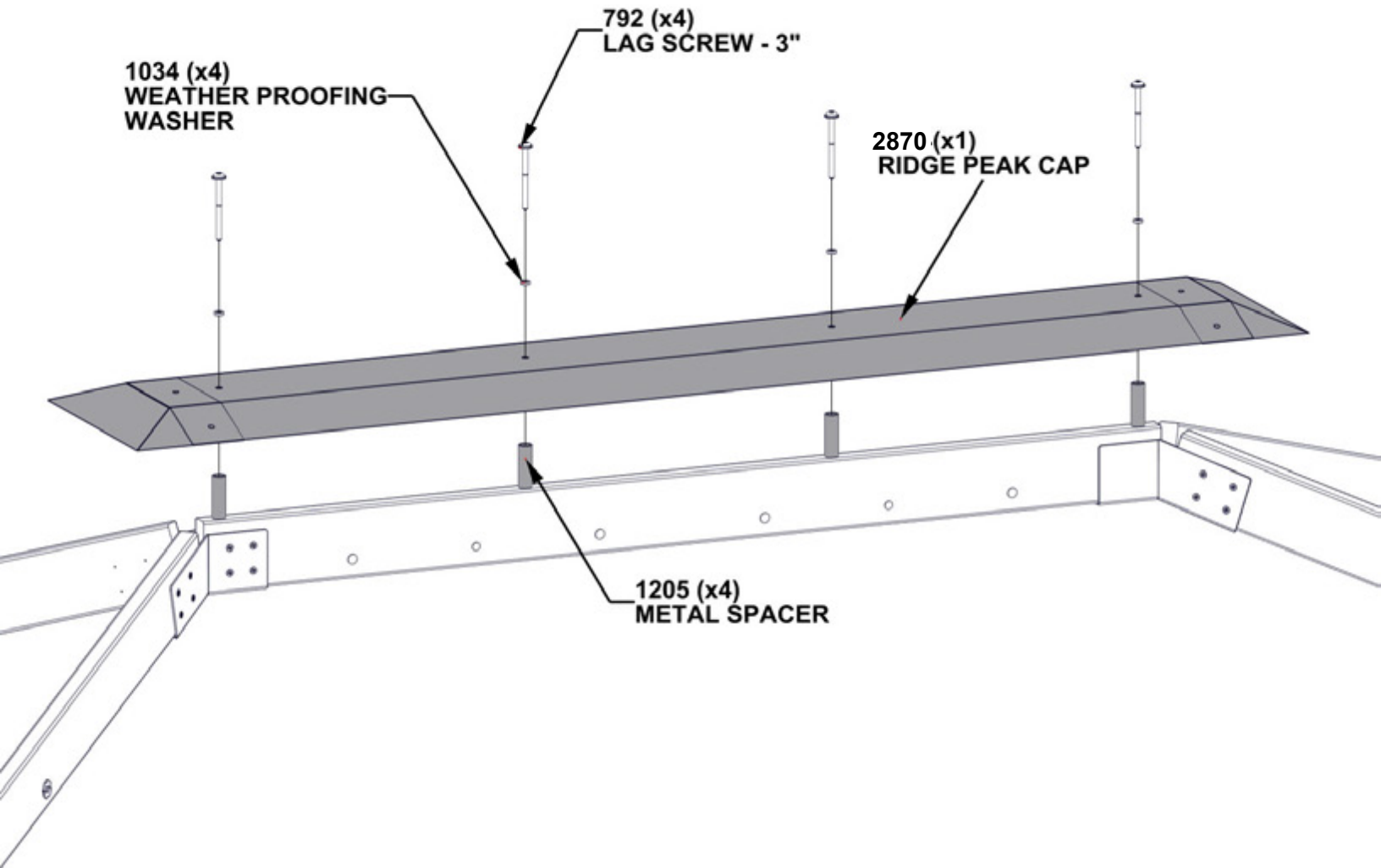

## STEP 17 - SUPPORT ASSEMBLY

**TIPS:**

**THREE PEOPLE ARE HELPFUL FOR THIS STEP.**

**POSITION A PERSON ON A LADDER IN THE CENTER OF THE BASE.**

**LIFT ROOF SUPPORT UP AND OVER THE 16FT SIDE AND INSERT INTO CORNER POST CLIPS.**

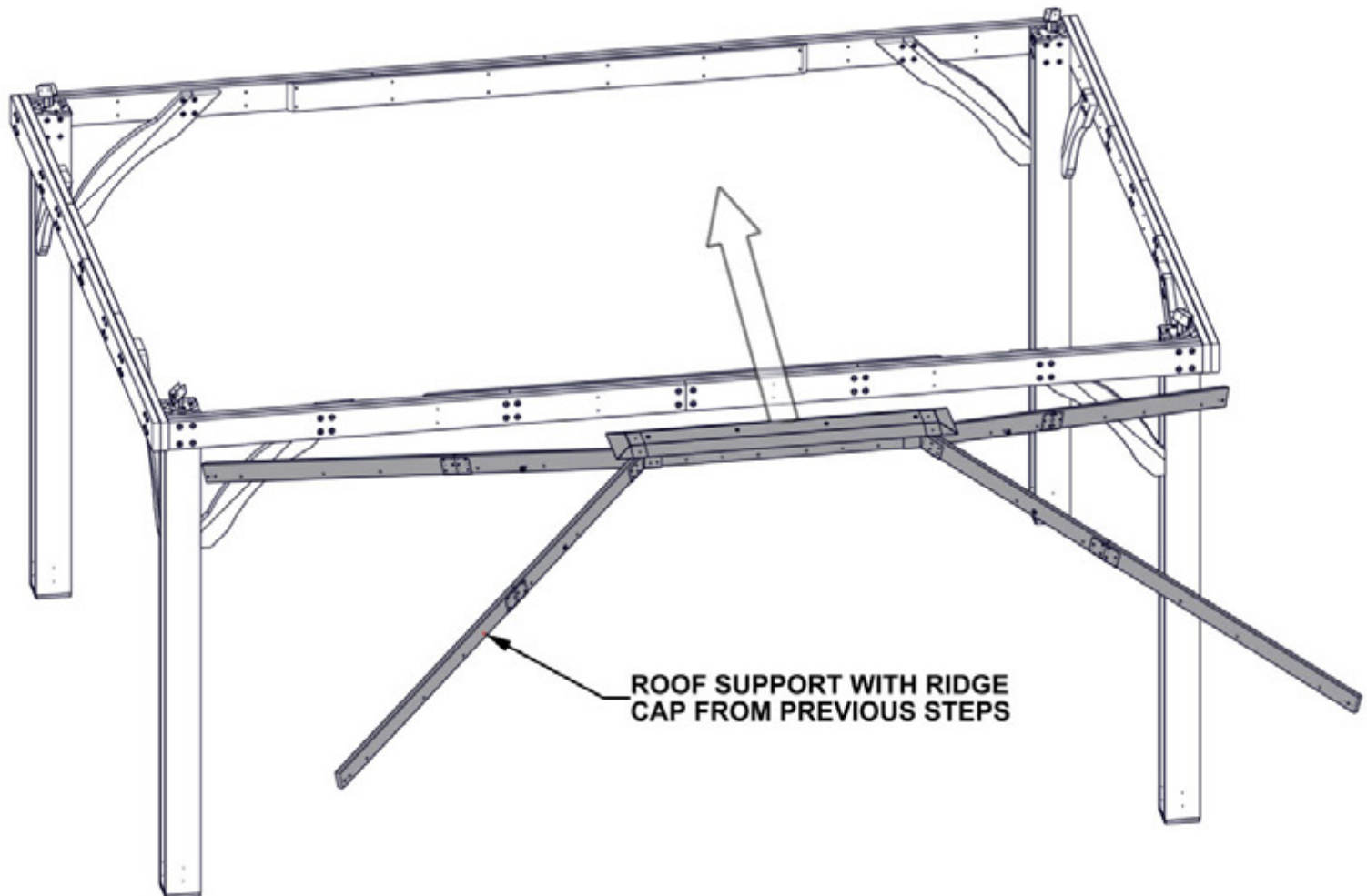

# STEP 18 - ROOF SUPPORT ASSEMBLY

Qty	PART NUMBER	DESCRIPTION
12	H100385	SCREW PFH 8x1 BLK

REPEAT ON ALL FOUR POST

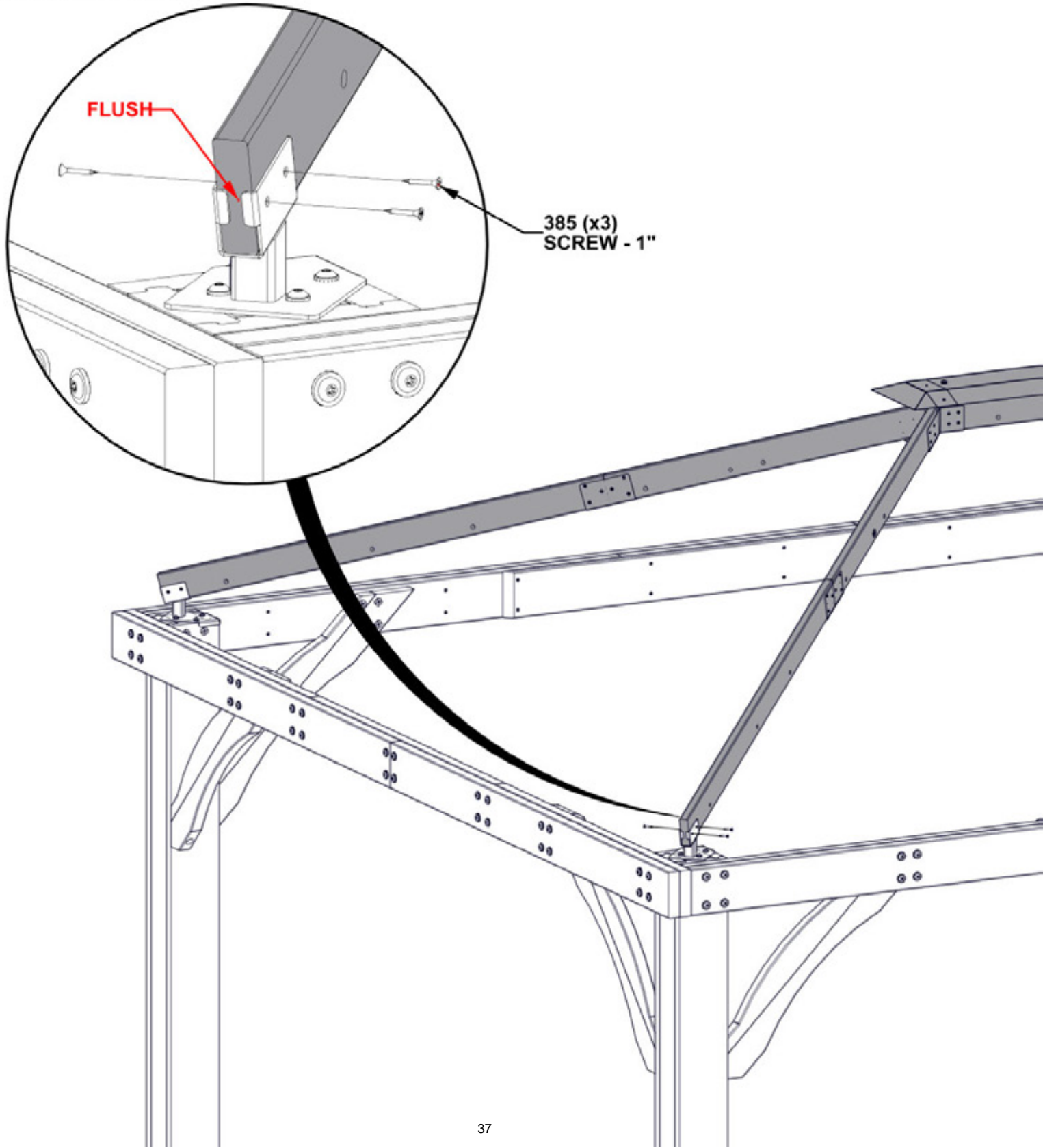

# STEP 19 - 16FT ROOF PANEL ASSEMBLY

Qty	PART NUMBER	DESCRIPTION
4	H100171	BOLT WH 1/4x1 BLK
4	H100398	T-NUT 1/4 BLK



**H03** | ROOF JOIST - W4L15288  
(1) | 1"x3 3/8"x46 7/8" (24x86x580)

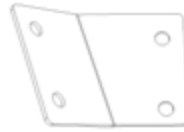

**A4M01193** | PANEL BRACKET  
(1)



**A4M01191** | PANEL BRACKET  
(1)

**INSERT T-NUTS FIRST  
HAND TIGHTEN ONLY**

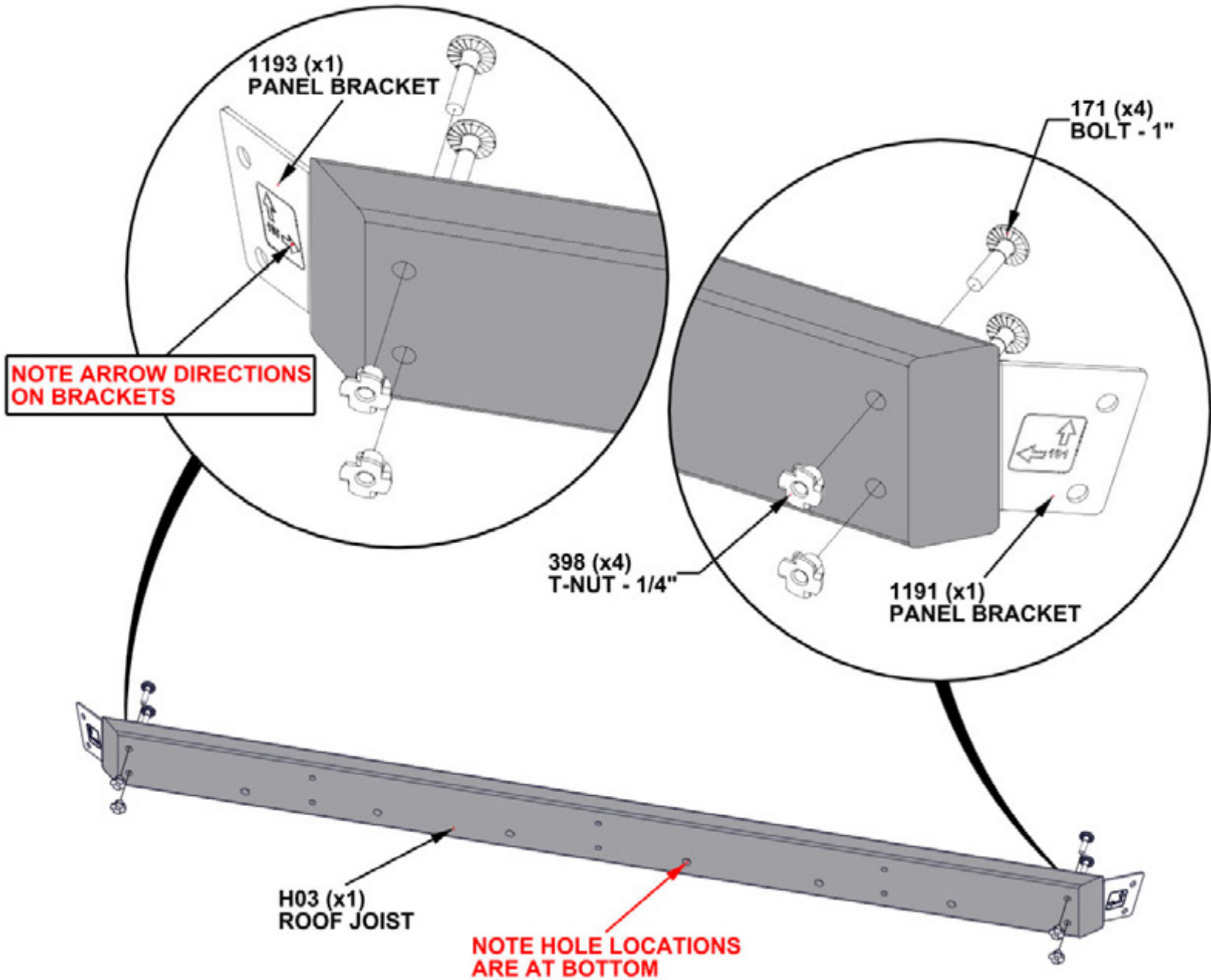

# STEP 20A - 16FT ROOF PANEL ASSEMBLY

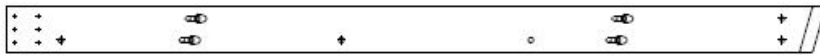

**H09** | ROOF JOIST- W4L15297  
(1) 1"x3 3/8"x61 1/4" (24x86x1556)

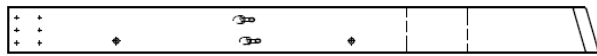

**H10** | ROOF JOIST- W4L15298  
(1) 1"x3 3/8"x44 1/2" (24x86x1130)



**H05** | ROOF JOIST - W4L15293  
(1) 1"x3 3/8"x44 1/2" (24x86x1130)

Qty	PART NUMBER	DESCRIPTION
24	H100385	SCREW PFH 8x1 BLK
4	H100398	T-NUT 1/4 BLK



**H02** | ROOF JOIST- W4L15289  
(1) 1"x3 3/8"x61 1/4" (24x86x1556)

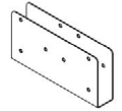

**A4M01237** | ROOF SUPPORT  
SPLICE CLIP  
(2)

## INSERT T-NUTS FIRST

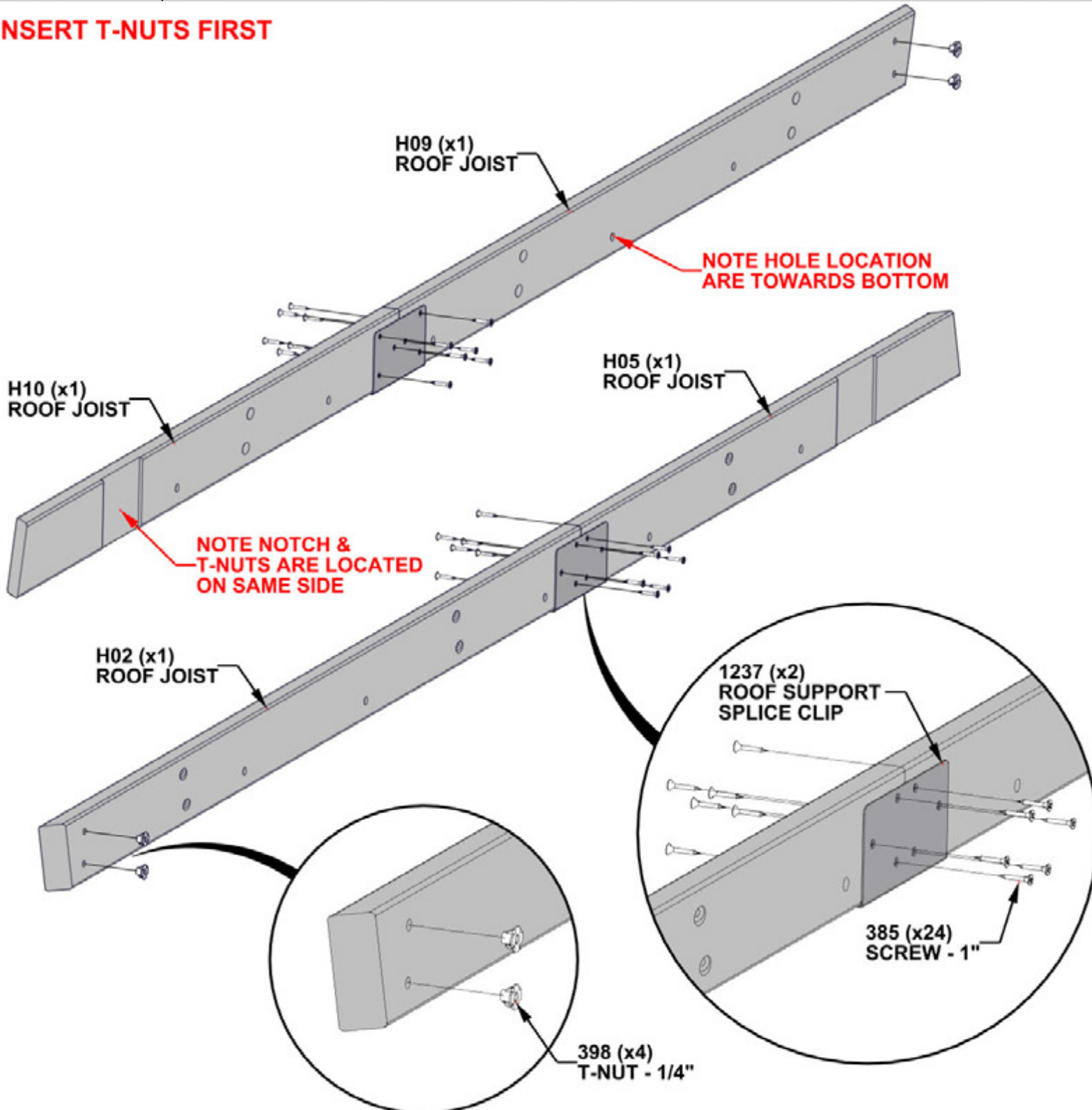

# STEP 20B - 16FT ROOF PANEL ASSEMBLY

Qty	PART NUMBER	DESCRIPTION
4	H100171	BOLT WH 1/4x1 BLK

H09/H10 (x1) ROOF JOIST ASSY'S  
FROM PREVIOUS STEP

H02/H05 (x1) ROOF JOIST ASSY'S  
FROM PREVIOUS STEP

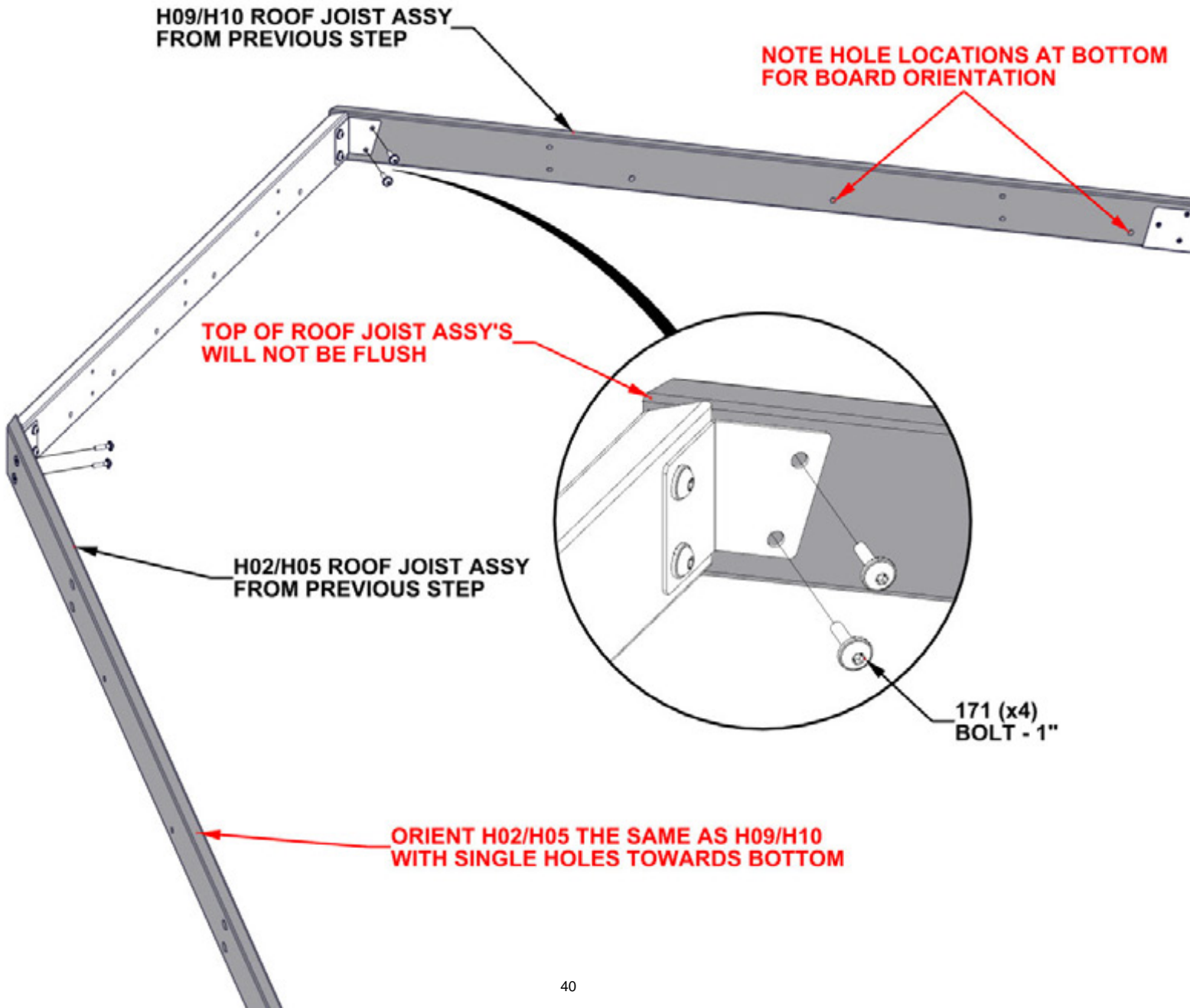

# STEP 21A - 16FT ROOF PANEL ASSEMBLY

Qty	PART NUMBER	DESCRIPTION
6	H101030	SCREW 2" CONFIRMAT



**E01** | RAFTER- W4L15312  
 (2) | 1 3/8"x3 3/8"x76 11/16" (36x86x1948)

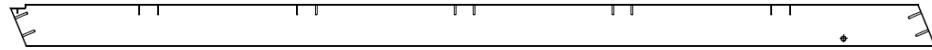

**E14** | RAFTER- W4L15299  
 (1) | 1 3/8"x3 3/8"x76 11/16" (36x86x1948)

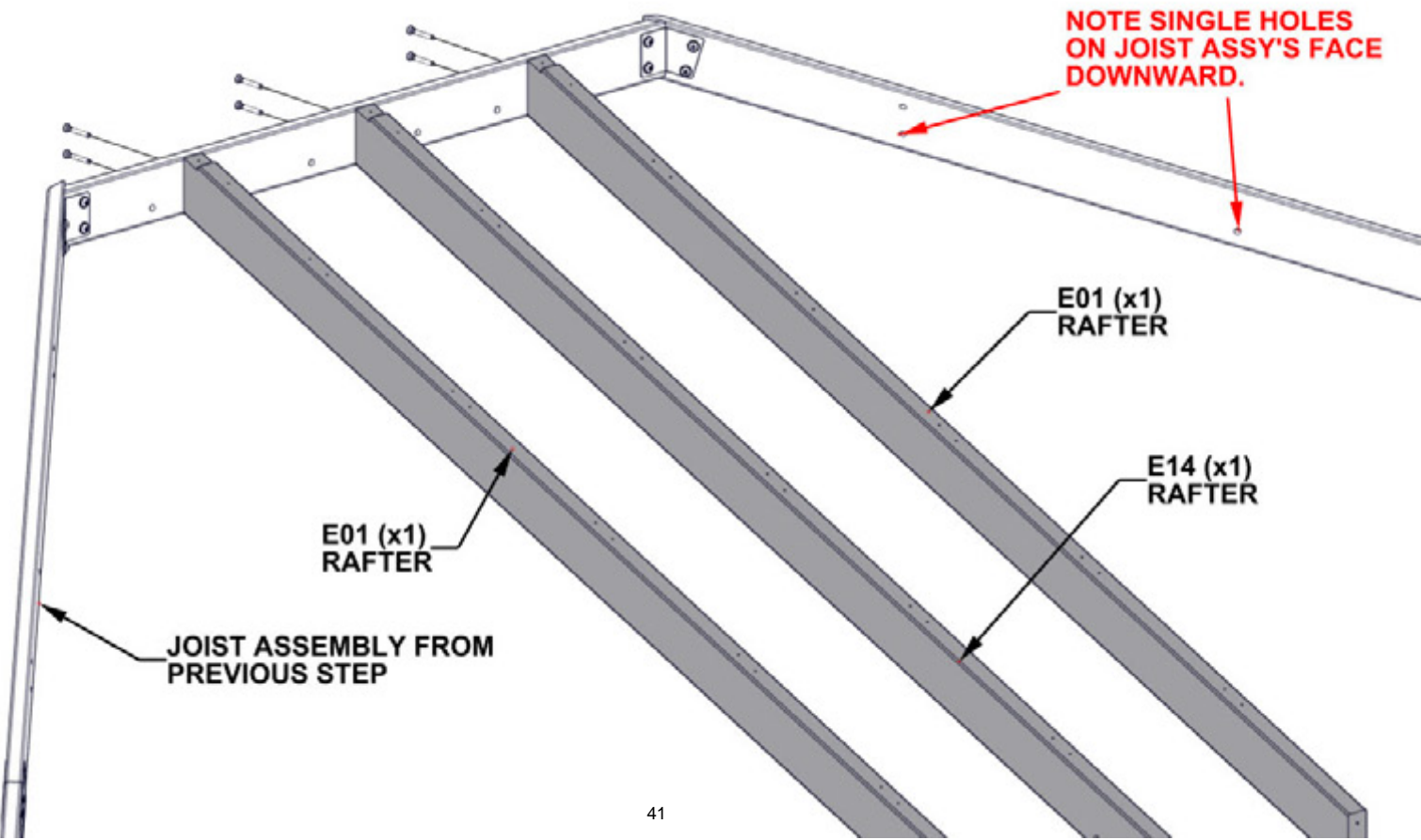
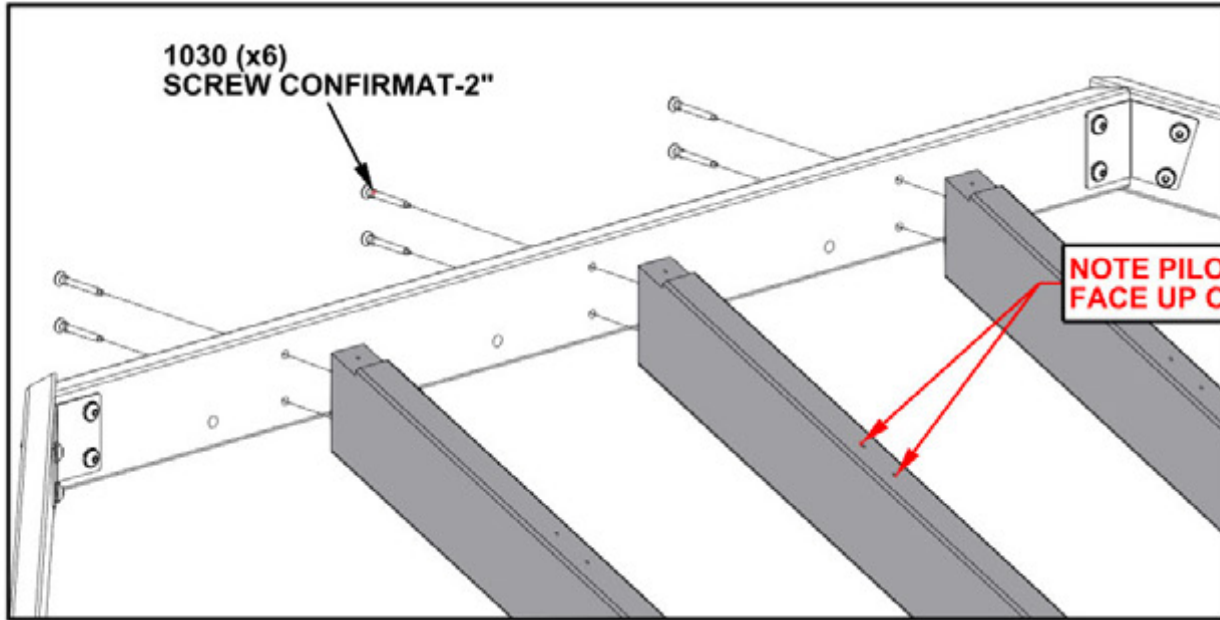

# STEP 21B - 16FT ROOF PANEL ASSEMBLY

Qty	PART NUMBER	DESCRIPTION
12	H101030	SCREW 2" CONFIRMAT

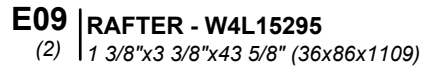
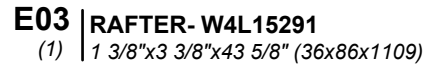
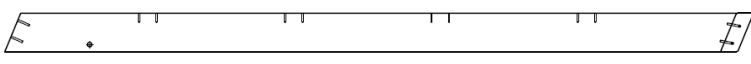
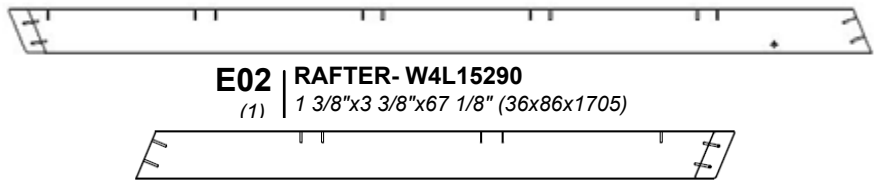
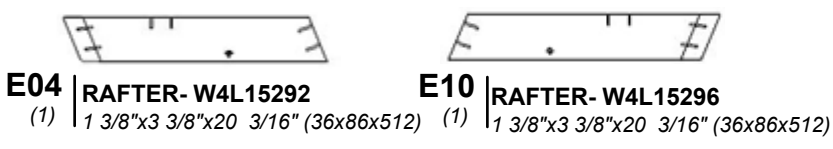

1030 (x12)  
SCREW CONFIRMAT-2"

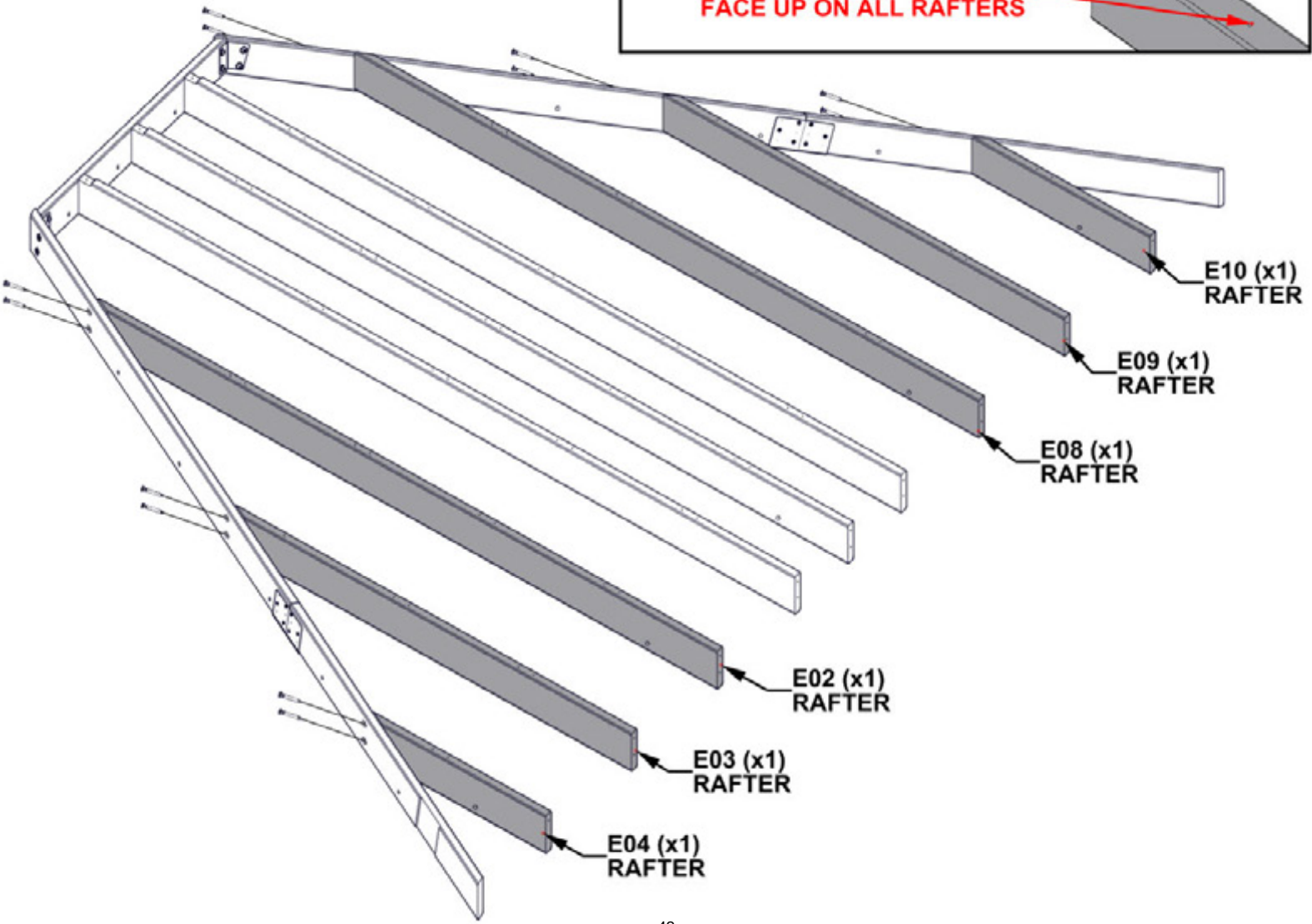
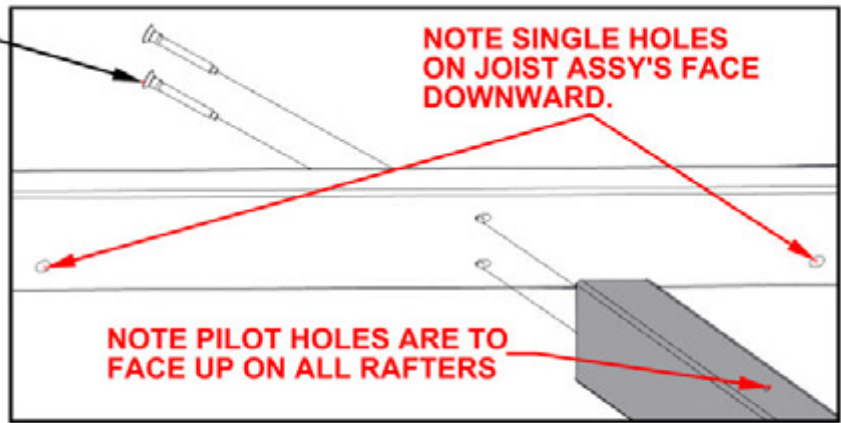

# STEP 22A - 16FT ROOF PANEL ASSEMBLY

Qty	PART NUMBER	DESCRIPTION
4	H100382	SCREW PFH 8x1 3/4 BLK
18	H101030	SCREW 2" CONFIRMAT



**Q02** | ROOF JOIST- W4L15300  
 (2) | 1"x4 7/16"x63 13/16" (24x112x1605)

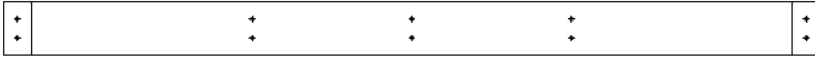

**Q04** | ROOF JOIST- W4L1301  
 (1) | 1"x4 7/16"x68 1/2" (24x112x1740)

**TIP: RAFTERS MAY NEED TO BE LOOSENED UP TO ATTACH Q02 TO H05/H10**

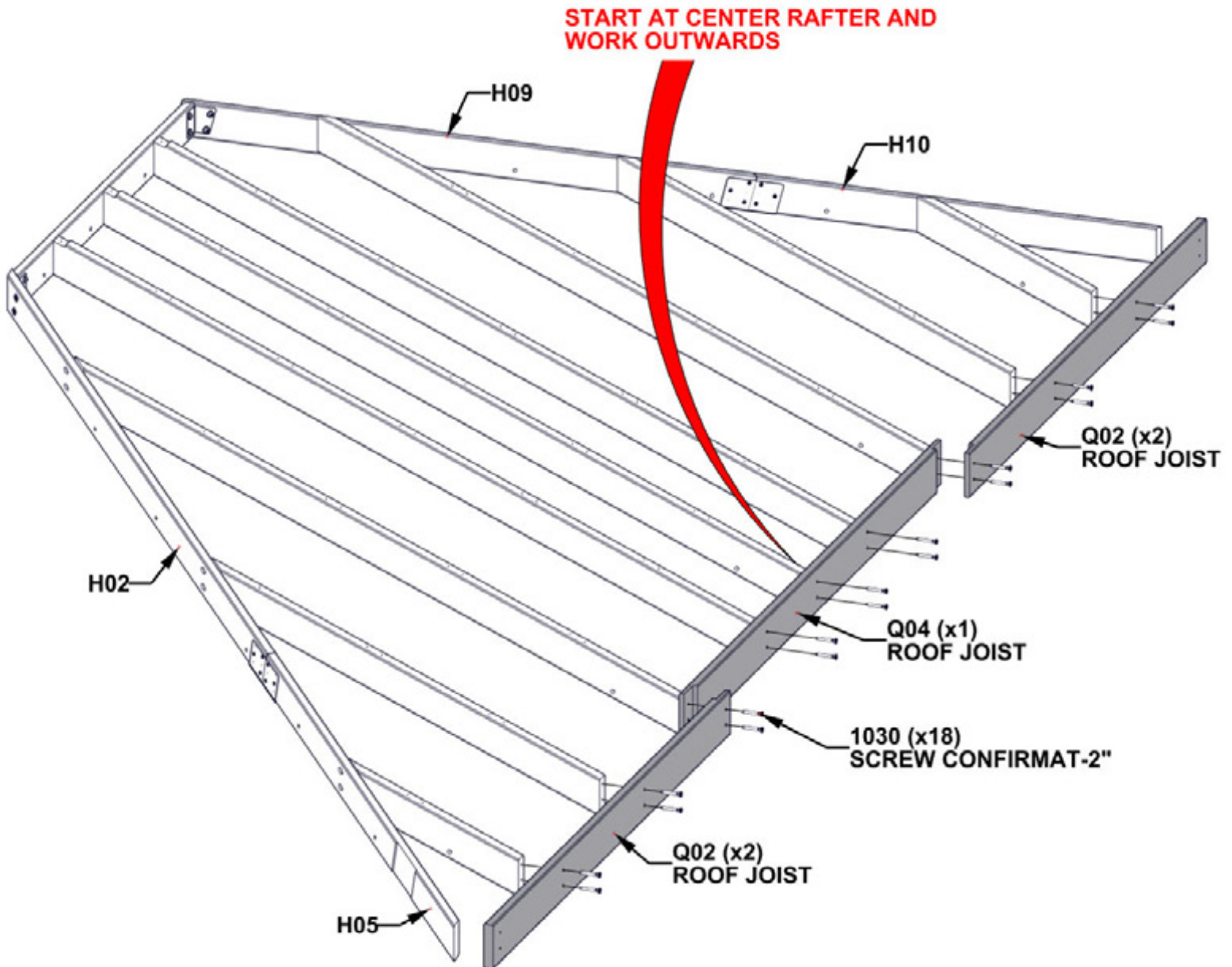

# STEP 22B - 164FT ROOF PANEL ASSEMBLY

**TIPS:**

USING THE Q02 BOARD AS A GUID AND A 1/8" DRILL BIT, DRILL PILOT HOLES INTO THE H05 BOARD  
USING THE DIMENSION BELOW.  
REPEAT ON OPPOSITE END WITH H10 BOARD.

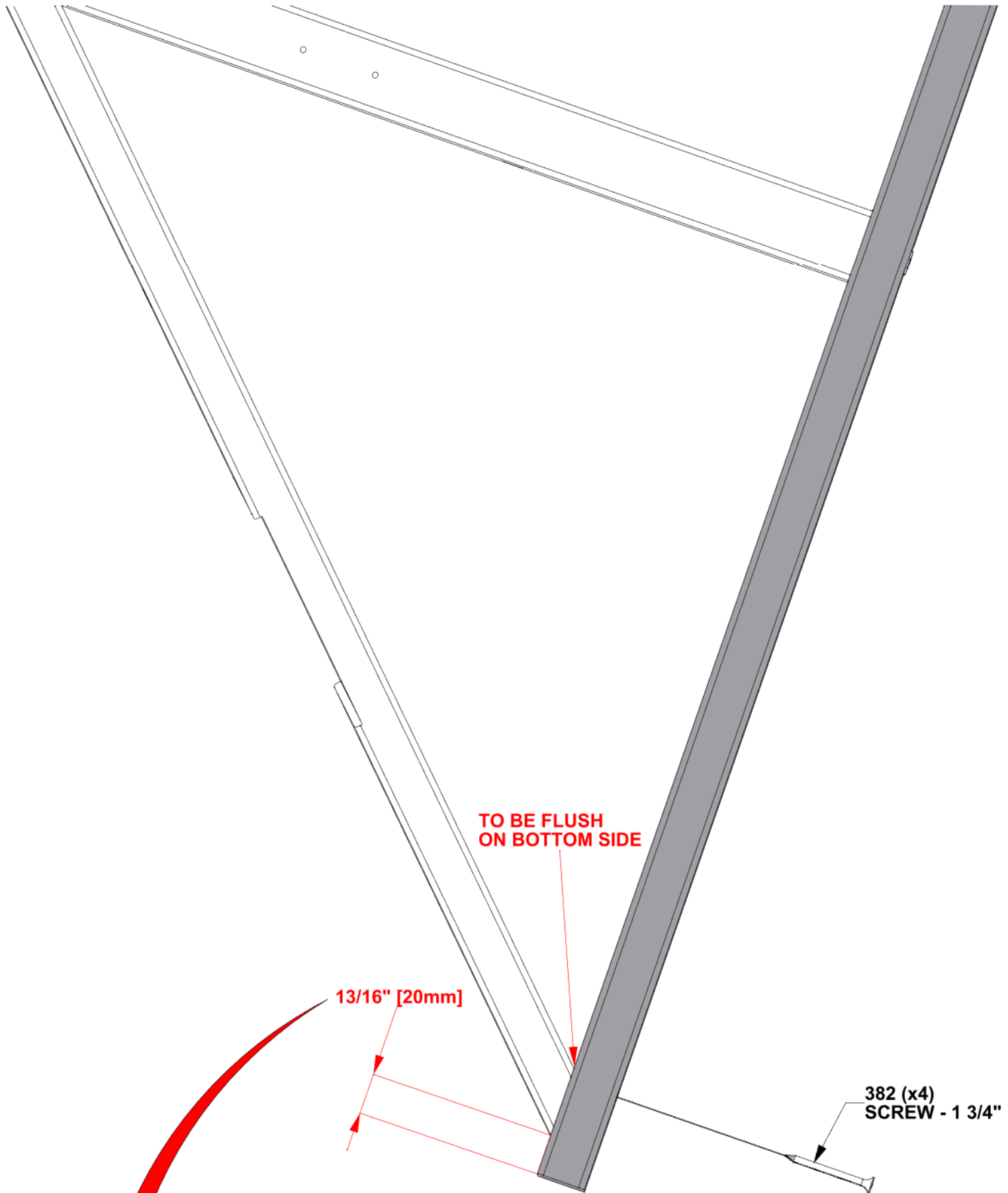

**THIS DIMENSION IS CRITICAL TO  
THE PANEL ASSEMBLY**

# STEP 22C - 16FT ROOF PANEL ASSEMBLY

TIP: LOOSEN HARDWARE TO ADJUST FOR SQUARING IF NEEDED.

**CRITICAL:**

- SQUARE UNIT BEFORE PROCEEDING TO NEXT STEPS.
- THE BELOW DIMENSIONS ARE CRITICAL TO THE FINAL ROOF ASSEMBLY.
- MEASUREMENTS SHOULD BE WITHIN +/- 1/4"
- MEASUREMENTS OUTSIDE OF TOLERANCE WILL LEAD TO THE INABILITY TO ASSEMBLE THE ROOF.

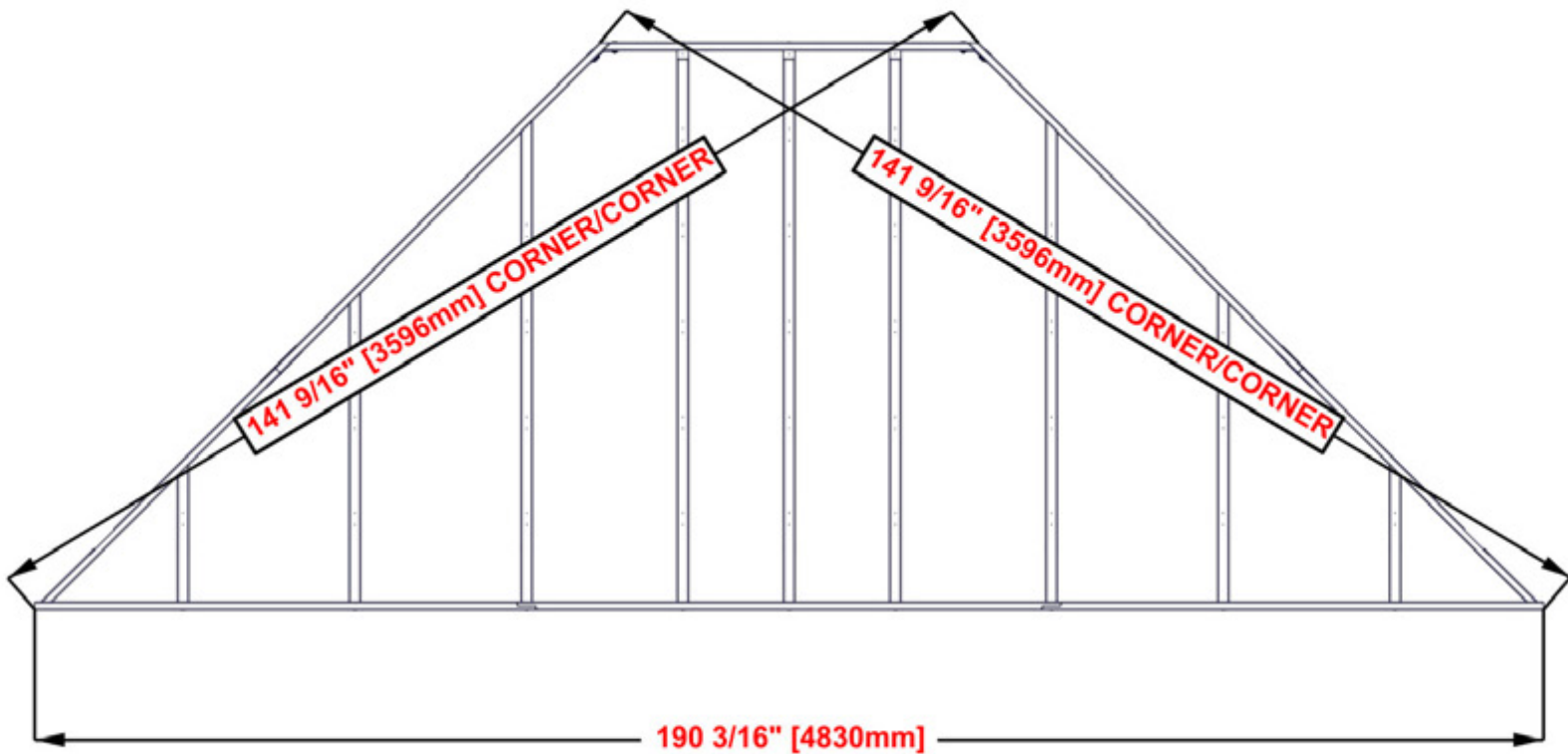

# STEP 23A - 16FT ROOF PANEL ASSEMBLY



**T01** | PURLIN - W4L15227  
 (1) | 1"x1 5/16"x51 1/2" (24x34x1308)

Qty	PART NUMBER	DESCRIPTION
3	H100200	SCREW PFH 8x1 1/2 BLK
42	H100391	SCREW PFH 8x2 BLK

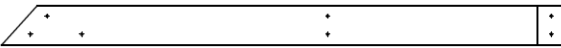

**H16** | PURLIN - W4L15305  
 (2) | 1"x3 3/8"x49 9/16" (24x86x1259)

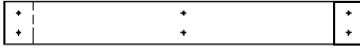

**H17** | PURLIN - W4L15306  
 (1) | 1"x1 3/8"x29 1/8" (24x86x740)

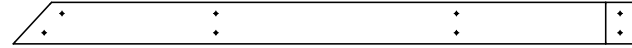

**H18** | PURLIN - W4L15307  
 (2) | 1"x3 3/8"x50 13/16" (24x86x1291)

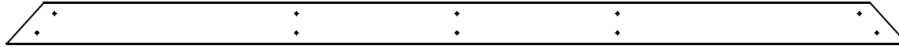

**H25** | PURLIN - W4L15308  
 (1) | 1"x3 3/8"x75 1/16" (24x86x1907)

- TIPS:**
- ALIGN PURLIN PILOT HOLES WITH RAFTER PILOT HOLES
  - ATTACH SCREWS FROM THE CENTER AND WORK OUTWARDS.
  - H02/H05 AND H09/H10 BOARDS DO NOT HAVE PILOT HOLES FOR OUTSIDE EDGE SCREWS.
  - USING THE PURLINS AS A GUIDE AND A 1/8" DRILL BIT, DRILL PILOT HOLES INTO H02/H05 AND H09/H10 BOARDS.

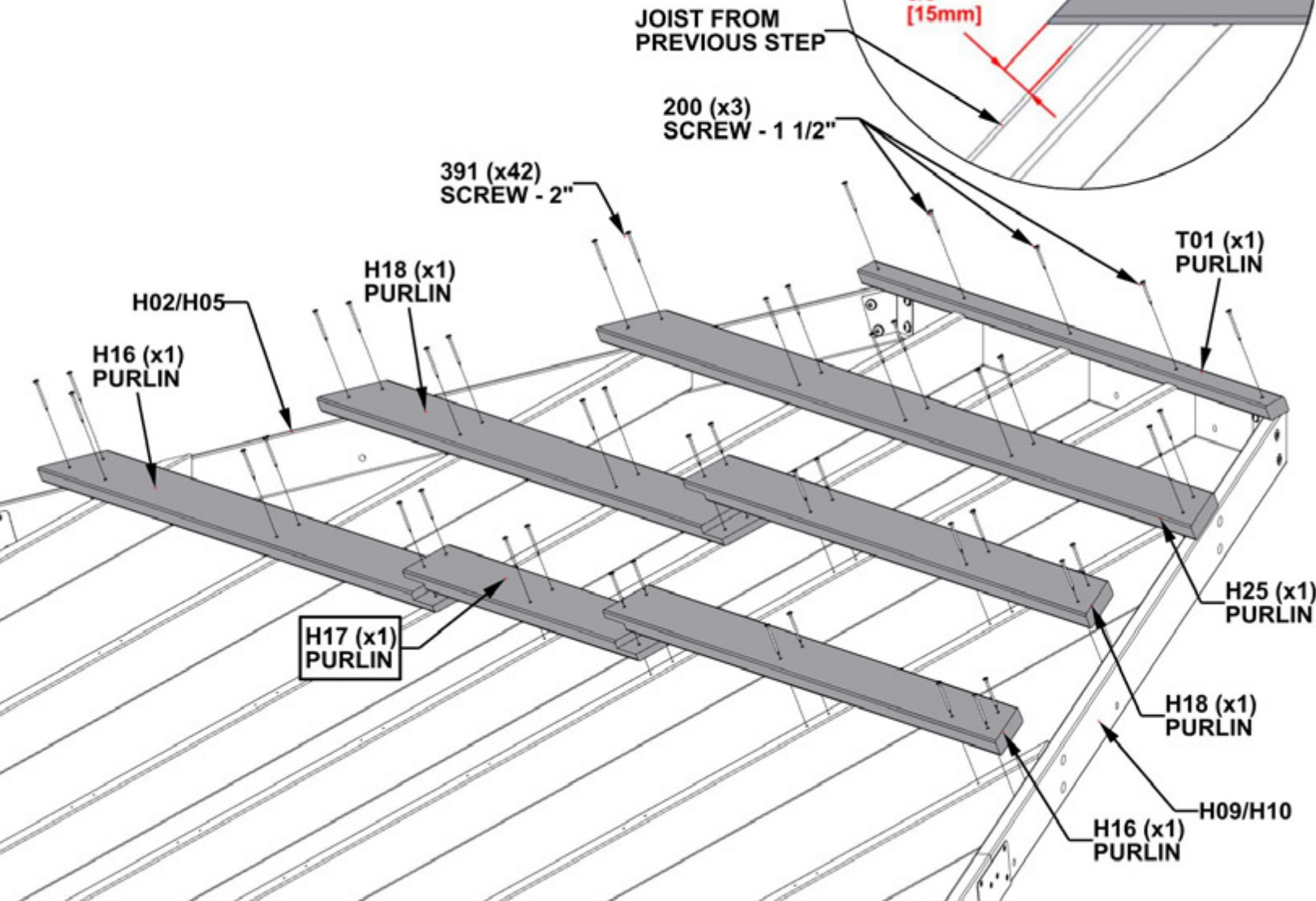
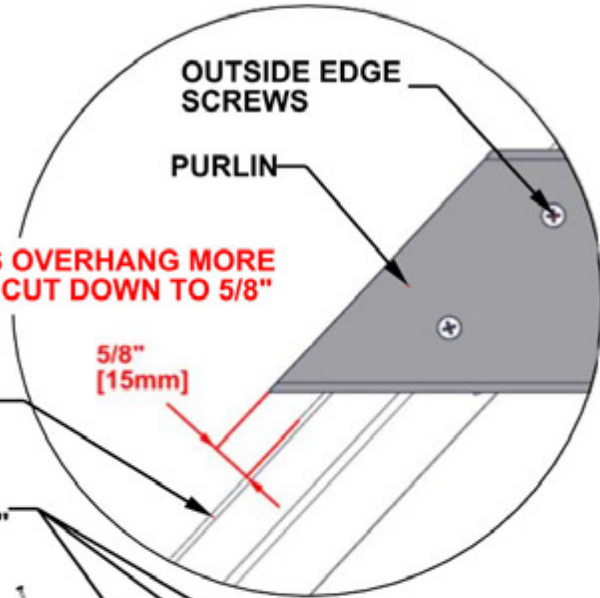

# STEP 23B - 16FT ROOF PANEL ASSEMBLY

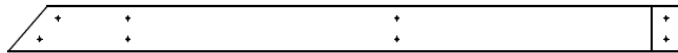

**H14** | PURLIN - W4L15303  
 (2) | 1"x3 3/8"x54 1/8" (24x86x1374)

Qty	PART NUMBER	DESCRIPTION
40	H100391	SCREW PFH 8x2 BLK

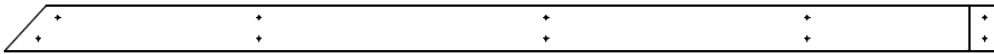

**H15** | PURLIN - W4L15304  
 (2) | 1"x3 3/8"x75 1/16" (24x86x1906)



**H13** | PURLIN - W4L15302  
 (1) | 1"x3 3/8"x68 1/2" (24x86x1740)

## TIPS:

- ALIGN PURLIN PILOT HOLES WITH RAFTER PILOT HOLES
- ATTACH SCREWS FROM THE CENTER AND WORK OUTWARDS.
- H02/H05 AND H09/H10 BOARDS DO NOT HAVE PILOT HOLES FOR OUTSIDE EDGE SCREWS.
- USING THE PURLINS AS A GUIDE AND A 1/8" DRILL BIT, DRILL PILOT HOLES INTO H02/H05 AND H09/H10 BOARDS.

**IF PURLINS OVERHANG MORE THAN 5/8", CUT DOWN TO 5/8"**

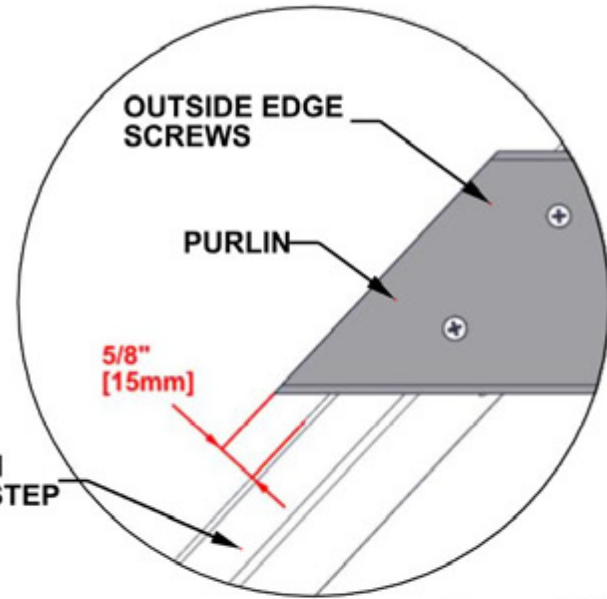

JOIST FROM PREVIOUS STEP

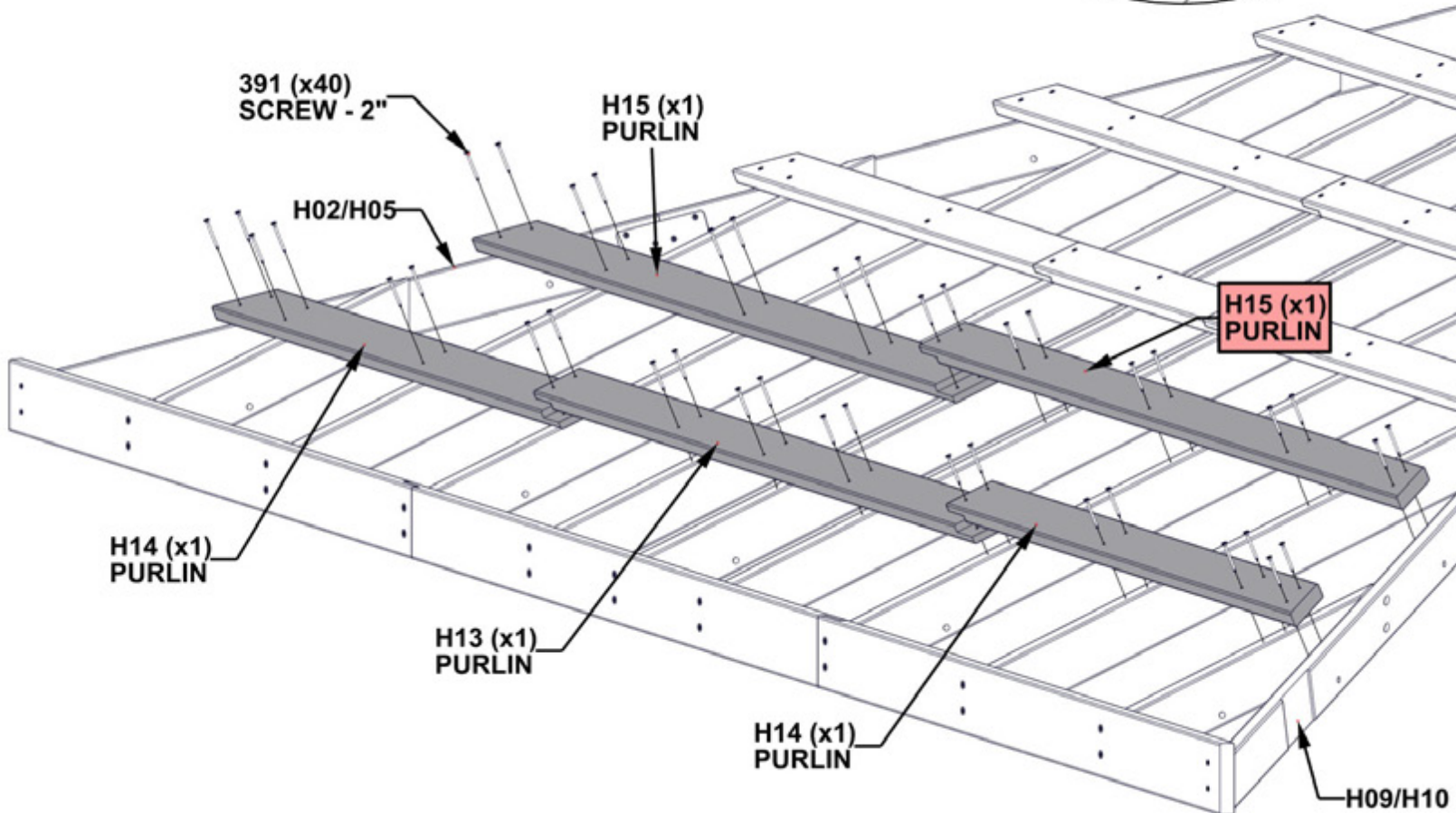

# STEP 24 - 16FT ROOF PANEL ASSEMBLY

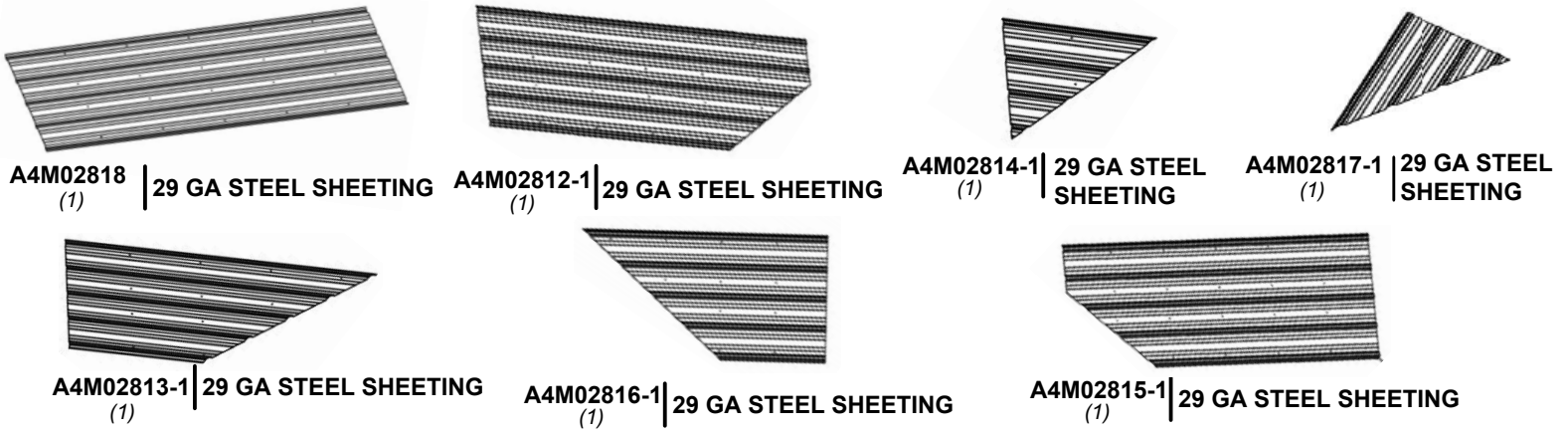

**TIPS:**

- REMOVE PROTECTIVE BLUE FILM.
- STARTING IN THE CENTER, PLACE PANELS AS SHOWN BELOW.
- OVERLAP PANELS BY ONE RIDGE.
- PANELS SHOULD BE FLUSH WITH PURLIN ENDS AND Q02 ROOF JOIST.
- ONCE SHEETING IS IN PLACE, IT IS RECOMMENDED TO ADD H100833 SCREWS IN THE MIDDLE OF THE SHEETS TO HOLD SHEETING FOR THE NEXT STEP.

Qty	PART NUMBER	DESCRIPTION
24	H100833	SCREW WOODGRIP 10-16x3/4

**WARNING: GLOVES ARE RECOMMENDED WHEN HANDLING STEEL ROOF PIECES**

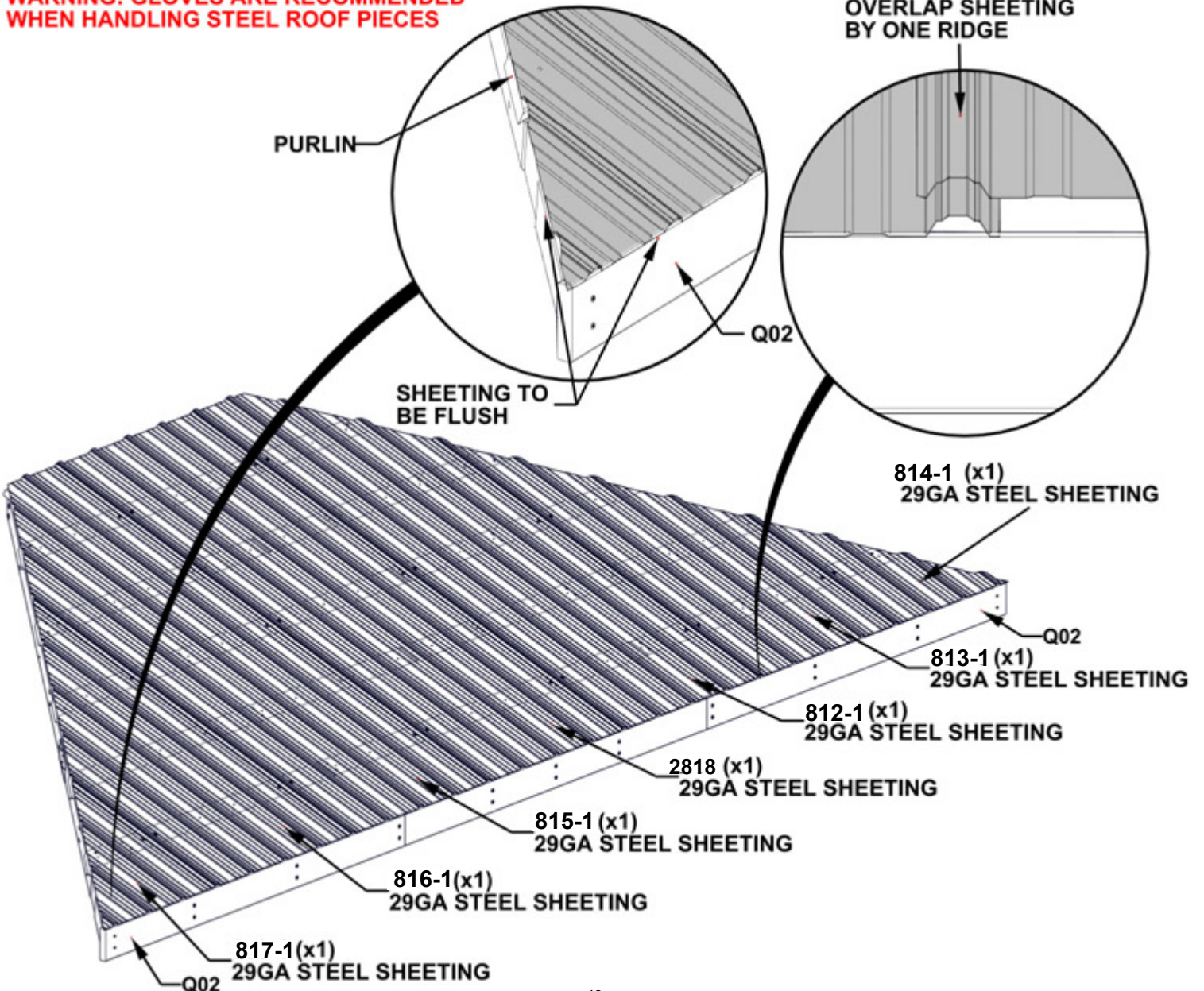

# STEP 25 - 16FT ROOF PANEL ASSEMBLY

Qty	PART NUMBER	DESCRIPTION
10	H100833	SCREW WOODGRIP 10-16x3/4

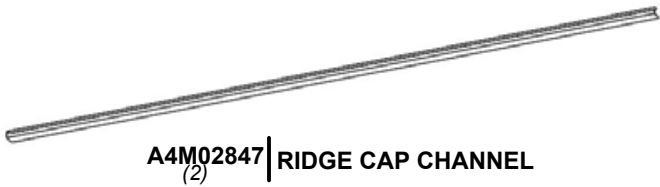

- TIPS:**
- POSITION THE RIDGE CAP CHANNEL OVER THE EDGE OF THE ROOF PANELS WITH THE WIDER SIDE OF THE CHANNEL ON THE BOTTOM.
  - MAKE SURE THE PANELS ARE FULLY SEATED INTO THE CHANNEL.
  - FLUSH THE TOP OF THE CHANNEL WITH THE TOP OF THE METAL PANELS.

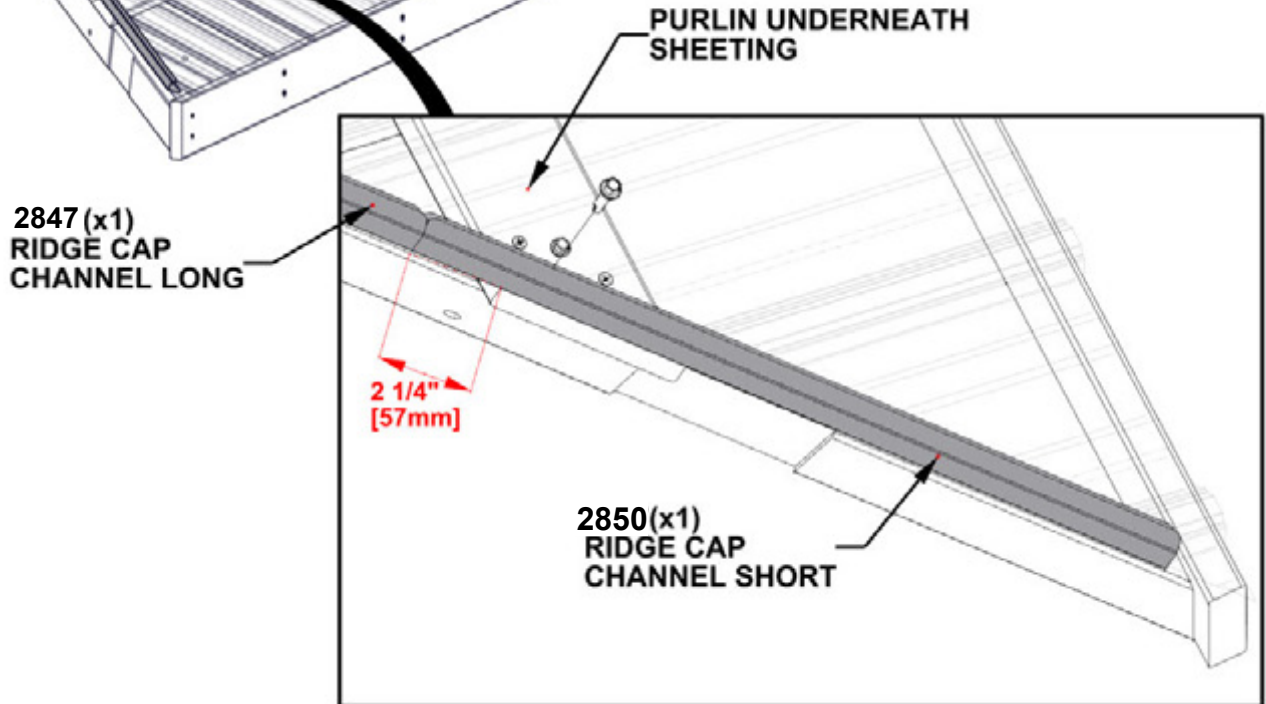
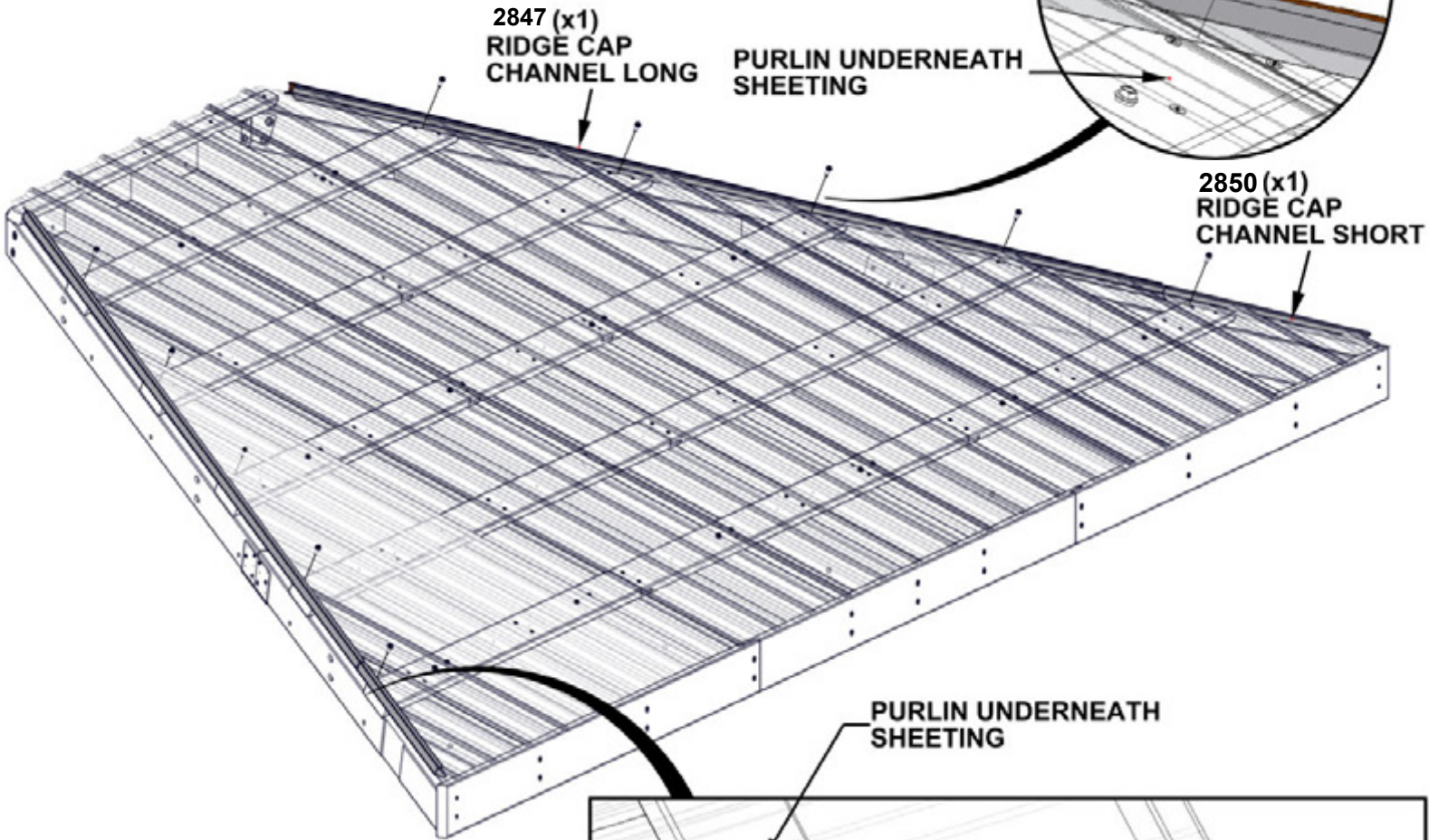

# STEP 26 - 16FT ROOF PANEL ASSEMBLY

Qty	PART NUMBER	DESCRIPTION
60	H100833	SCREW WOODGRIP 10-16x3/4

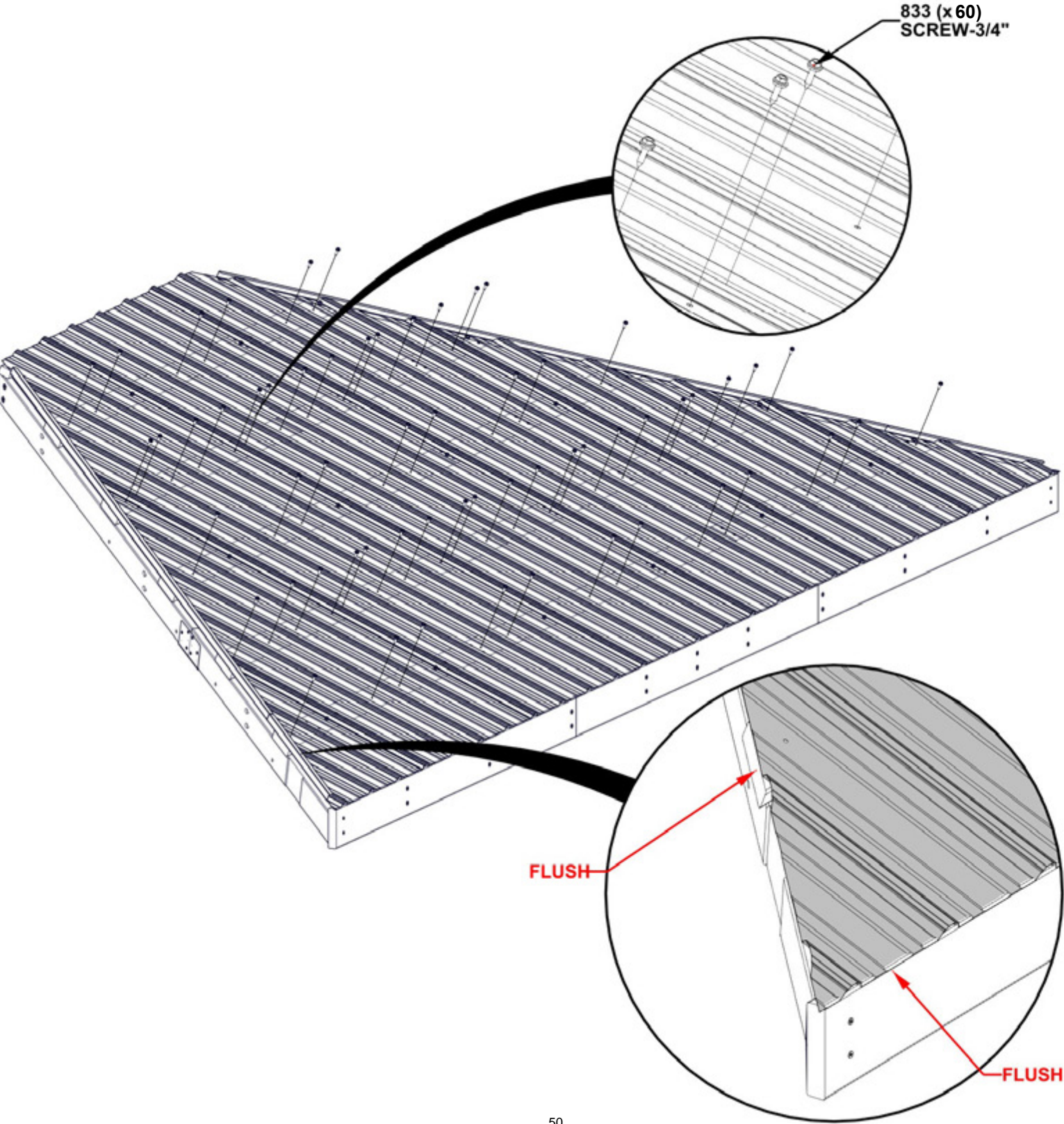

**REPEAT 16FT ROOF PANEL  
ASSEMBLY STEPS 19 THROUGH 26**

# STEP 27 - 12FT ROOF PANEL ASSEMBLY

Qty	PART NUMBER	DESCRIPTION
4	H100171	BOLT WH 1/4x1 BLK
4	H100398	T-NUT 1/4 BLK

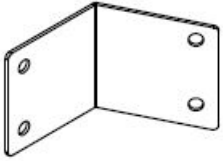

A4M01238 (1) | PANEL BRACKET

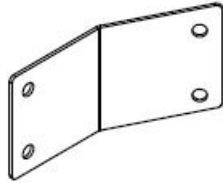

A4M01239 (1) | PANEL BRACKET

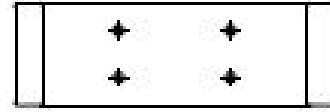

H06 | ROOF JOIST - W4L15203  
(1) 1"x3 3/8"x10 11/16" (24x86x272)

**INSERT T-NUTS FIRST  
HAND TIGHTEN ONLY**

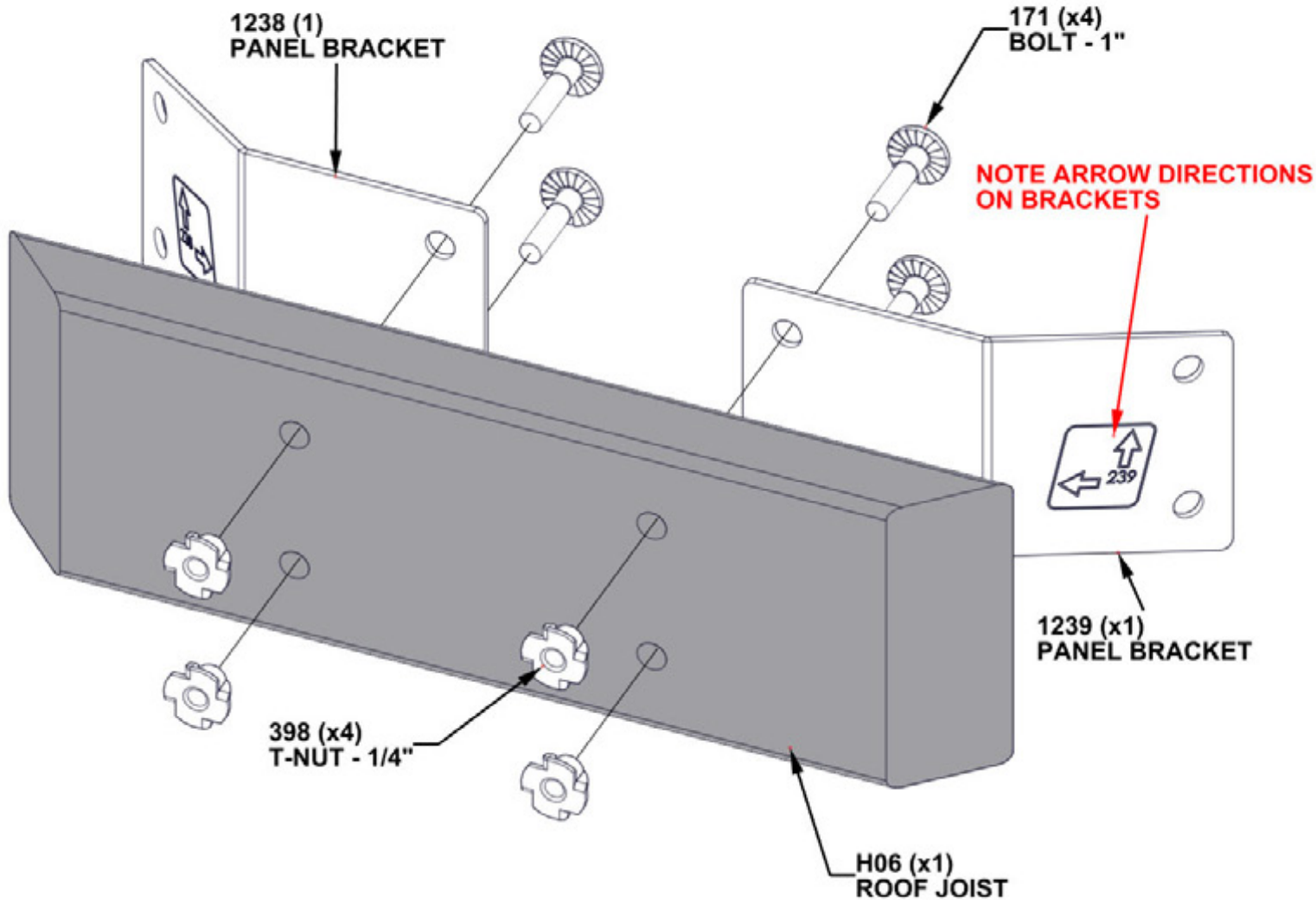

# STEP 28 - 12FT ROOF PANEL ASSEMBLY

Qty	PART NUMBER	DESCRIPTION
4	H100171	BOLT WH 1/4x1 BLK
24	H100385	SCREW PFH 8x1 BLK
4	H100398	T-NUT 1/4 BLK



**H11** | ROOF JOIST- W4L15216  
(1) 1"x3 3/8"x44 1/2" (24x86x1130)



**H12** | ROOF JOIST- W4L15220  
(1) 1"x3 3/8"x44 1/2" (24x86x1130)

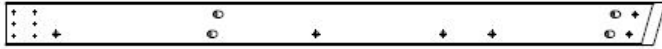

**H07** | ROOF JOIST - W4L15315  
(1) 1"x3 3/8"x53 3/16" (24x86x1351)

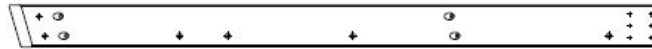

**H08** | ROOF JOIST - W4L15316  
(1) 1"x3 3/8"x53 3/16" (24x86x1351)

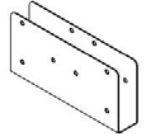

**A4M01237** | ROOF SUPPORT SPLICE CLIP  
(2)

## INSERT T-NUTS FIRST

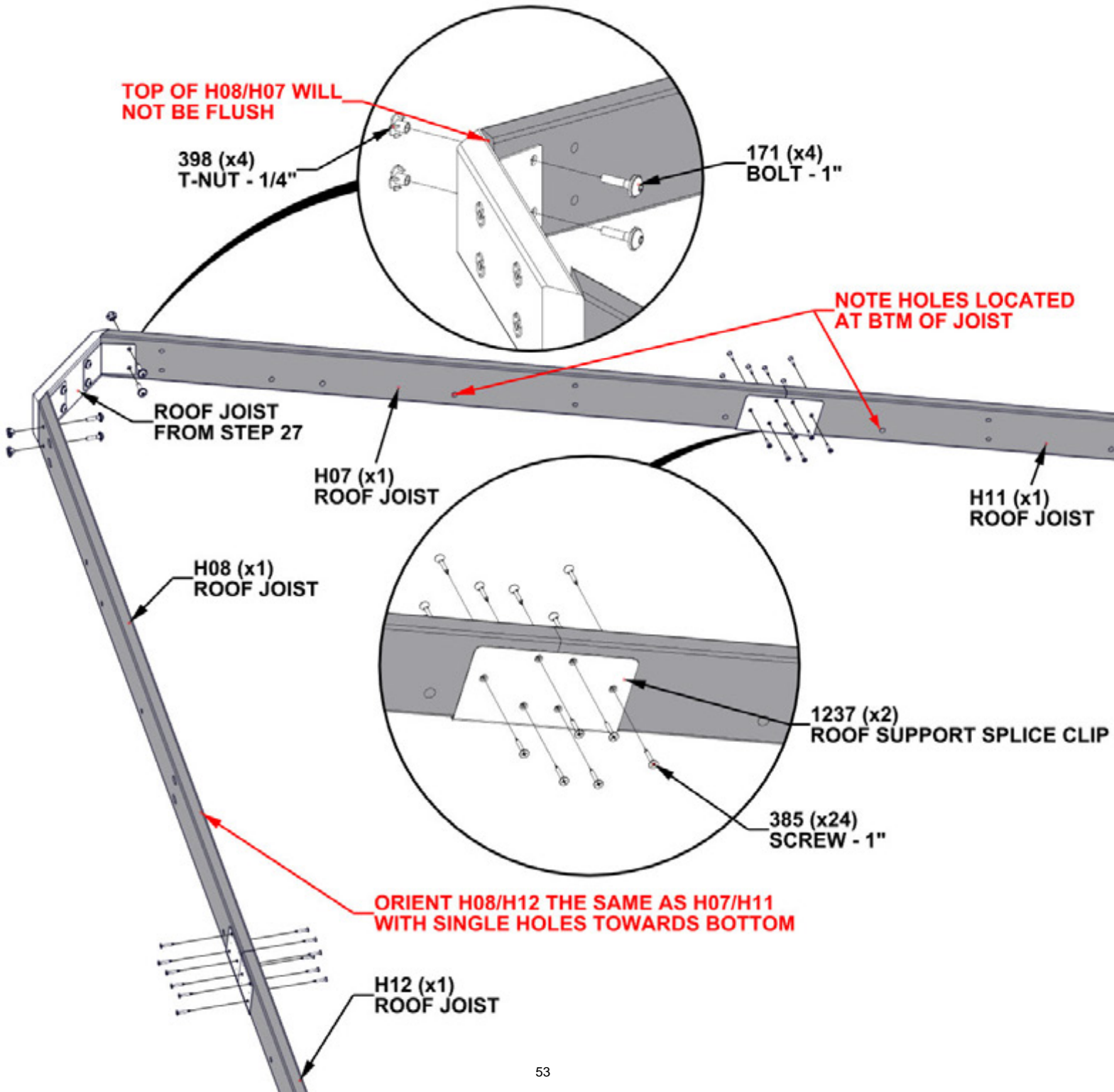

# STEP 29 - 12FT ROOF PANEL ASSEMBLY

Qty	PART NUMBER	DESCRIPTION
12	H101030	SCREW 2" CONFIRMAT

**E05** | RAFTER - W4L15207  
(1) | 1 3/8"x3 3/8"x69" (36x86x1752)

**E11** | RAFTER- W4L15217  
(1) | 1 3/8"x3 3/8"x69" (36x86x1752)

**E12** | RAFTER W4L15218  
(1) | 1 3/8"x3 3/8"x45 7/16" (36x86x1155)

**E06** | RAFTER - W4L15208  
(1) | 1 3/8"x3 3/8"x45 7/16" (36x86x1155)

**E07** | RAFTER- W4L15209  
(1) | 1 3/8"x3 3/8"x21 15/16" (36x86x557)

**E13** | RAFTER- W4L15219  
(1) | 1 3/8"x3 3/8"x21 15/16" (36x86x557)

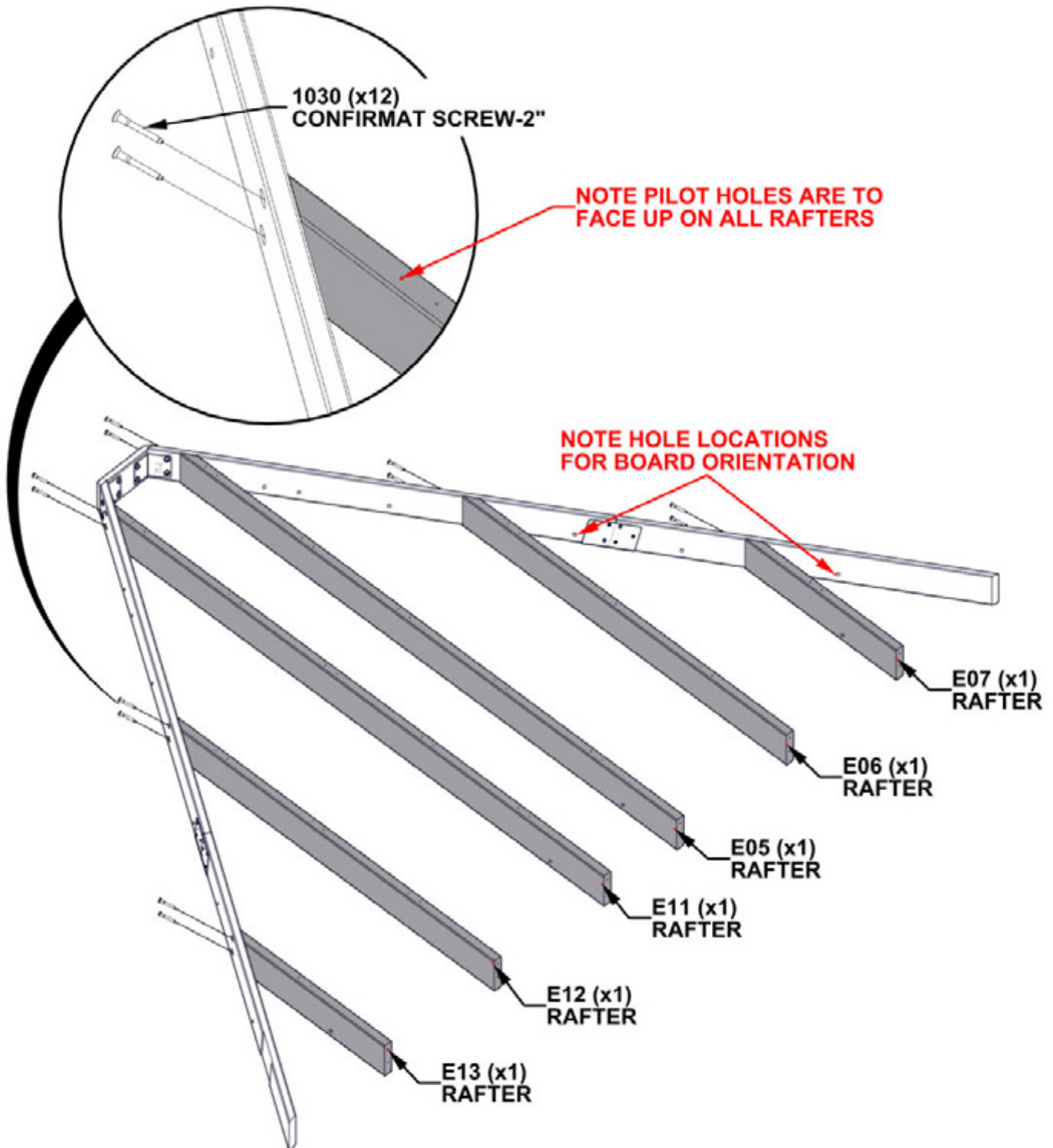

# STEP 30A - 12FT ROOF PANEL ASSEMBLY

Qty	PART NUMBER	DESCRIPTION
4	H100382	SCREW PFH 8x1 3/4 BLK
12	H101030	SCREW 2" CONFIRMAT



**Q03** | ROOF JOIST- W4L15221  
(1) | 1"x4 7/16"x80 1/2" (24x112x2044)



**Q01** | ROOF JOIST- W4L15204  
(1) | 1"x4 7/16"x65 15/16" (24x112x1675)

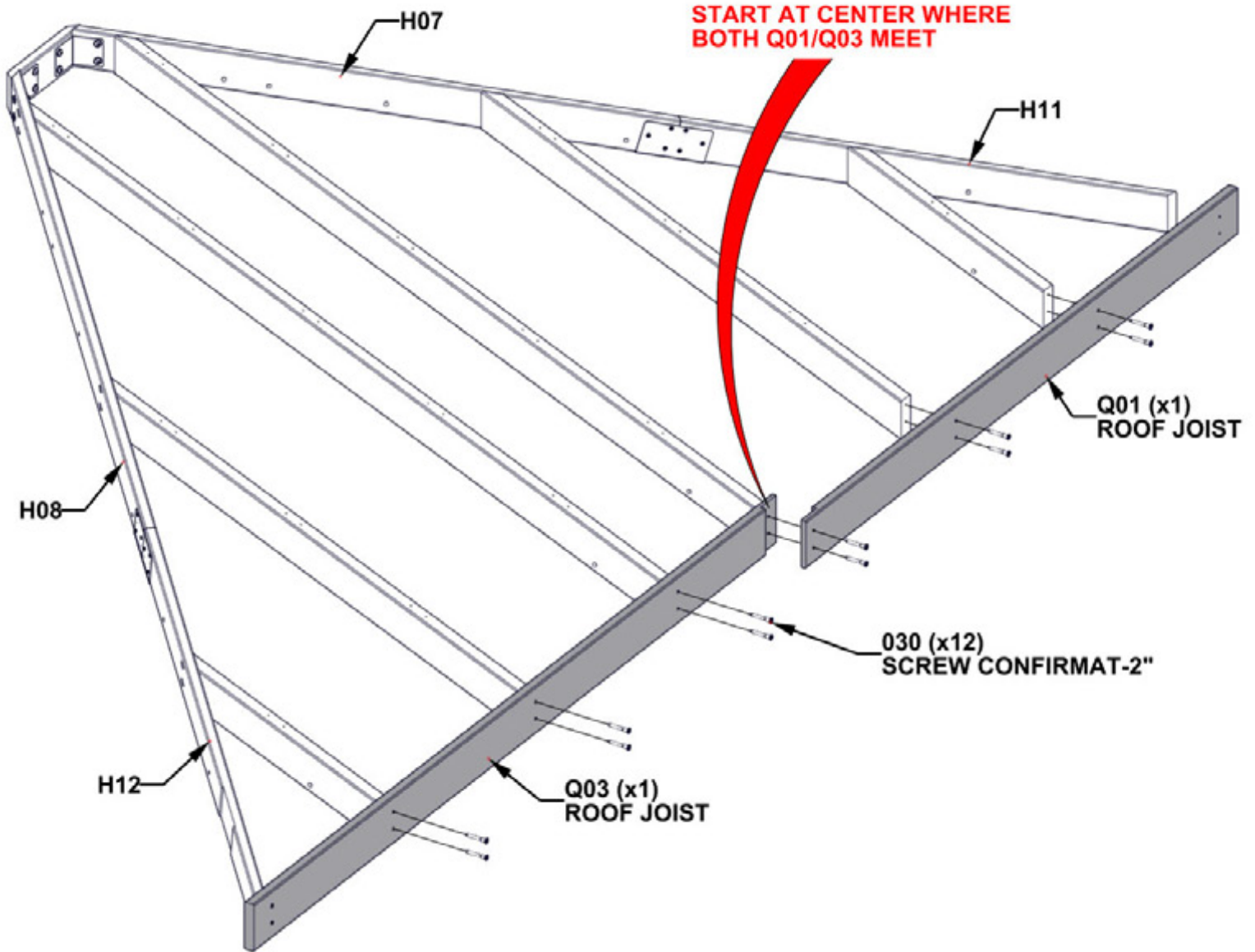

# STEP 30B - 12FT ROOF PANEL ASSEMBLY

## TIPS:

- USING THE Q03 BOARDS AS A GUIDE AND A 1/8" DRILL BIT, DRILL PILOT HOLES INTO THE H12 BOARD USING THE DIMENSION BELOW.
- REPEAT ON OPPOSITE END USING Q01 AS A GUIDE TO DRILL PILOT HOLES INTO THE H11 BOARD.

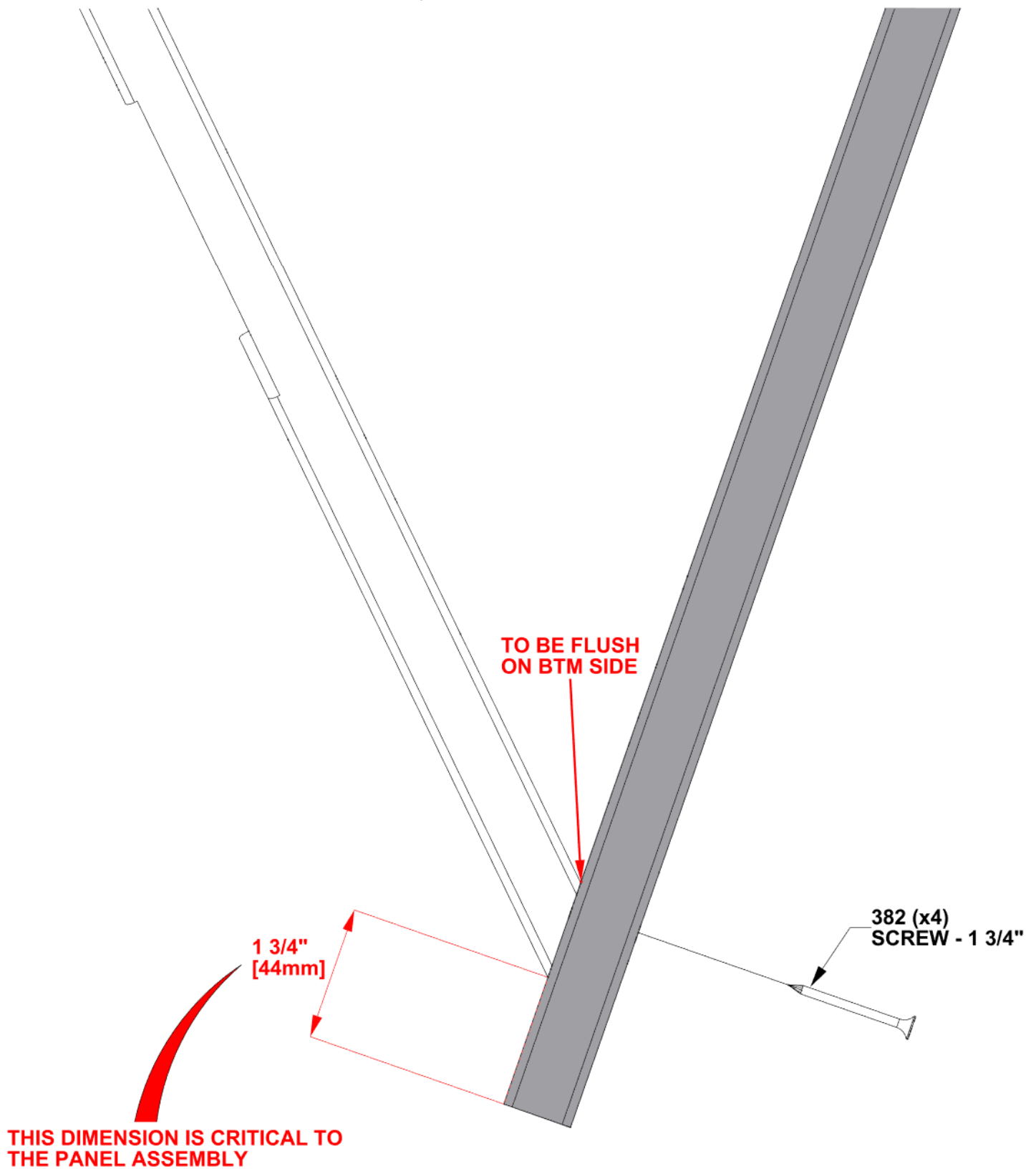

# STEP 30C - 12FT ROOF PANEL ASSEMBLY

**TIP: LOOSEN HARDWARE TO ADJUST FOR SQUARING IF NEEDED.**

**CRITICAL:**

- SQUARE UNIT BEFORE PROCEEDING TO NEXT STEPS.
- THE BELOW DIMENSIONS ARE CRITICAL TO THE FINAL ROOF ASSEMBLY.
- MEASUREMENTS SHOULD BE WITHIN +/- 1/4"
- MEASUREMENTS OUTSIDE OF TOLERANCE WILL LEAD TO THE INABILITY TO ASSEMBLE THE ROOF.

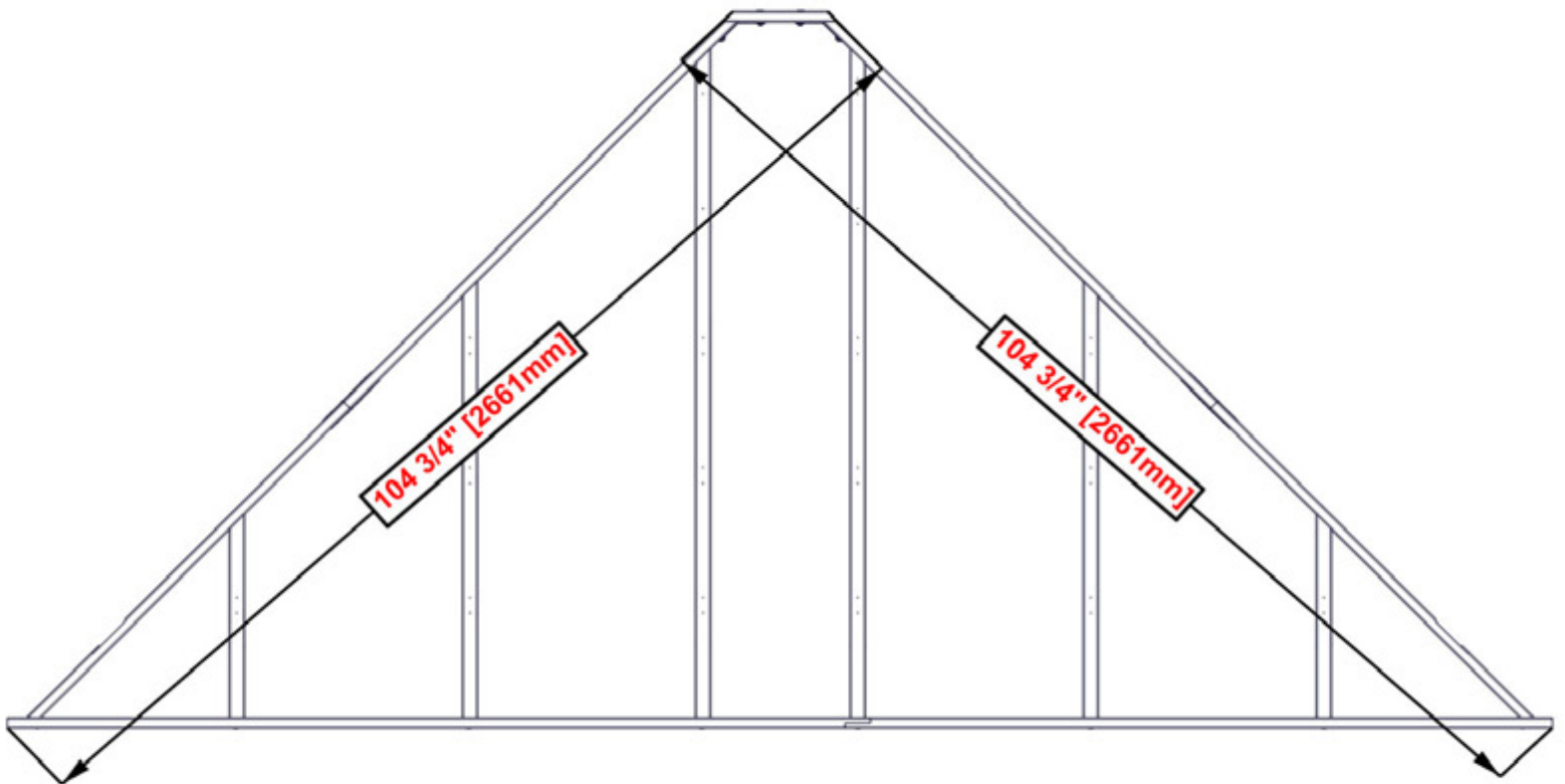

# STEP 31 - 12FT ROOF PANEL ASSEMBLY

<b>T02</b>   PURLIN- W4L15239 (1)   1"x1 5/16"x12 3/4" (24x34x324)	<b>H24</b>   PURLIN W4L15232 (1)   1"x3 3/8"x27 1/4" (24x86x692)	<b>H27</b>   PURLIN- W4L15237 (1)   1"x3 3/8"x56" (24x86x1422)
<b>H22</b>   PURLIN- W4L15231 (1)   1"x3 3/8"x51 7/16" (24x86x1307)	<b>H19</b>   PURLIN- W4L15228 (1)   1"x3 3/8"x58 5/16" (24x86x1481)	<b>H20</b>   PURLIN- W4L15229 (1)   1"x3 3/8"x43 7/8" (24x86x1114)
<b>H21</b>   PURLIN- W4L15230 (1)   1"x3 3/8"x75 11/16" (24x86x1922)		
<b>H28</b>   PURLIN- W4L15238 (1)   1"x3 3/8"x70 1/2" (24x86x1791)		

QTY.	PART NUMBER	DESCRIPTION
58	H100391	SCREW PFH 8x2 BLK

- TIPS:**
- ALIGN PURLIN PILOT HOLES WITH RAFTER PILOT HOLES.
  - ATTACH SCREWS FROM THE CENTER AND WORK OUTWARD.
  - H08/H12 & H07/H11 BOARDS DO NOT HAVE PILOT HOLES FOR OUTSIDE EDGE SCREWS.
  - USING THE PURLINS AS A GUIDE AND A 1/8" DRILL BIT, DRILL PILOT HOLES INTO H08/H12 & H07/H11 BOARDS

**NOTE T02 IS TO BE FLUSH AND WILL NOT OVERHANG SIDES**

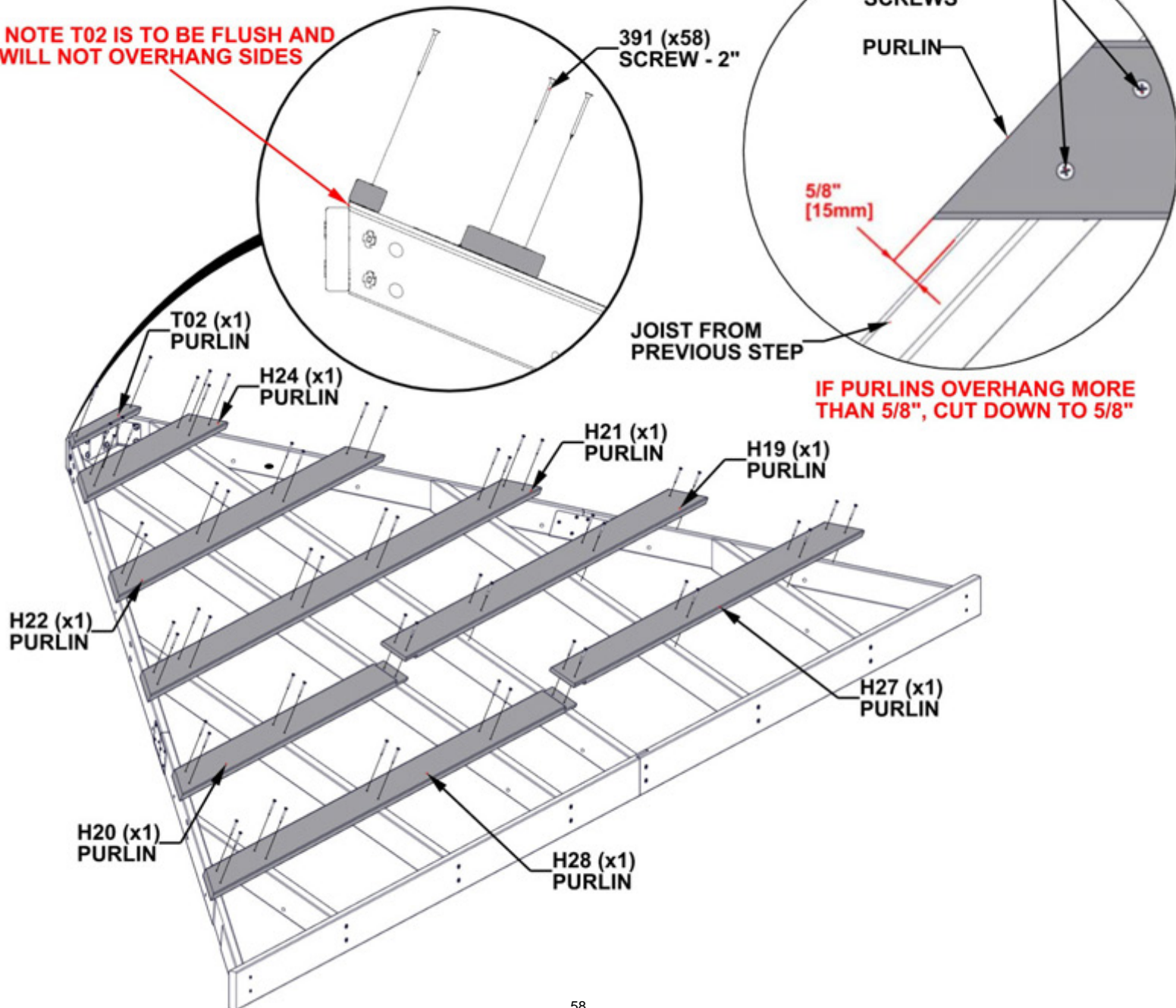

# STEP 32 - 12FT ROOF PANEL ASSEMBLY

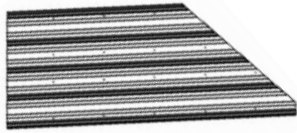

A4M02817-2 | 29 GA STEEL SHEETING  
(1)

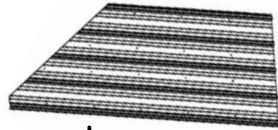

A4M02814-2 | 29 GA STEEL SHEETING  
(1)

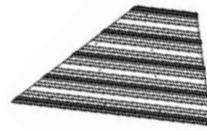

A4M02813-2 | 29 GA STEEL SHEETING  
(1)



A4M02812-2 | 29 GA STEEL SHEETING  
(1)



A4M02815-2 | 29 GA STEEL SHEETING  
(1)

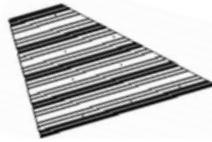

A4M02816-2 | 29 GA STEEL SHEETING  
(1)

Qty	PART NUMBER	DESCRIPTION
20	H100833	SCREW WOODGRIP 10-16x3/4

- TIPS:**
- REMOVE PROTECTIVE BLUE FILM.
  - STARTING IN THE CENTER, PLACE PANELS AS SHOWN BELOW.
  - OVERLAP PANELS BY ONE RIDGE.
  - PANELS SHOULD BE FLUSH WITH PURLIN ENDS AND Q02 ROOF JOIST.
  - ONCE SHEETING IS IN PLACE, IT IS RECOMMENDED TO ADD H100833 SCREWS IN THE MIDDLE OF THE SHEETS TO HOLD SHEETING FOR THE NEXT STEP.

**WARNING: GLOVES ARE RECOMMENDED WHEN HANDLING STEEL ROOF PIECES**

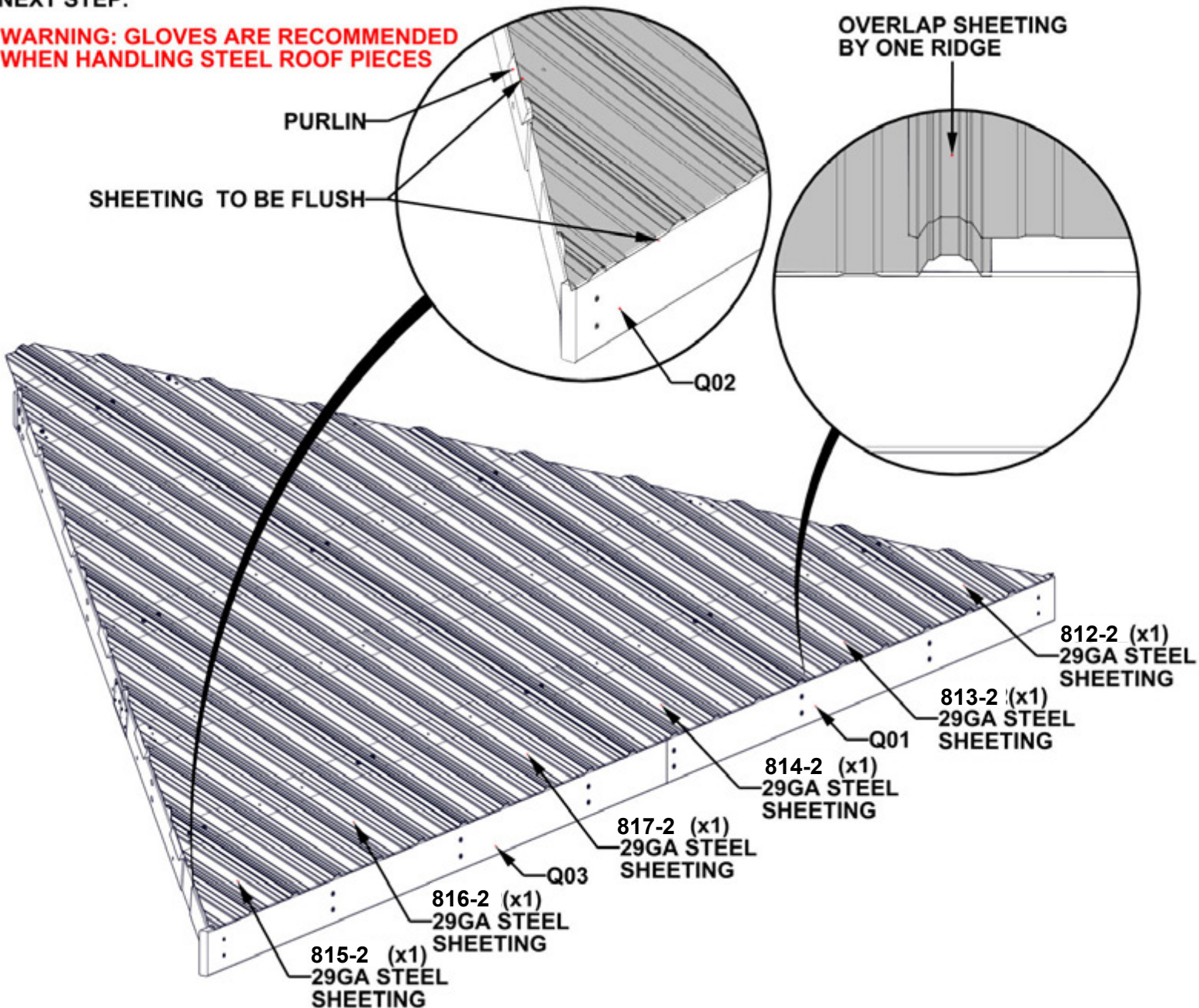

# STEP 33 - 12FT ROOF PANEL ASSEMBLY

Qty	PART NUMBER	DESCRIPTION
8	H100833	SCREW WOODGRIP 10-16x3/4

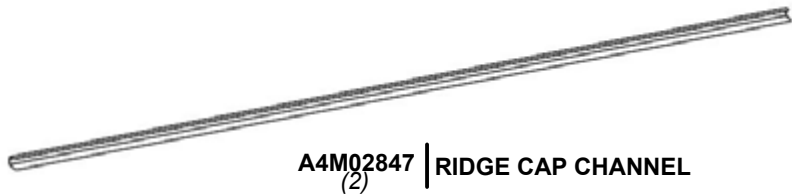

- TIPS:**
- POSITION THE RIDGE CAP CHANNEL OVER THE EDGE OF THE ROOF PANELS WITH THE WIDER SIDE OF THE CHANNEL ON THE BOTTOM.
  - MAKE SURE THE PANELS ARE FULLY SEATED INTO THE CHANNEL.
  - FLUSH THE TOP OF THE CHANNEL WITH THE TOP OF THE METAL PANELS.

833(x8)  
SCREW-3/4"

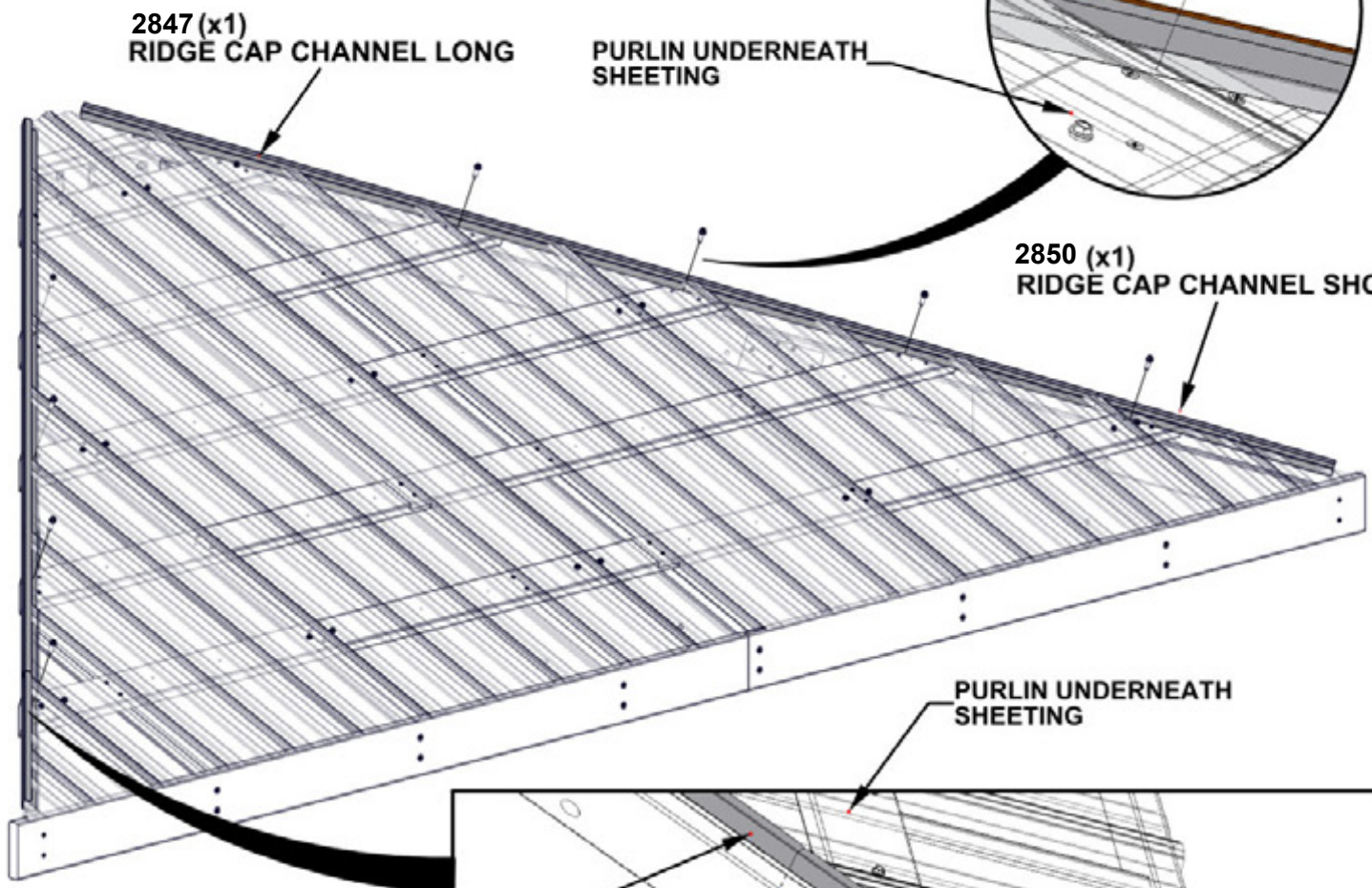
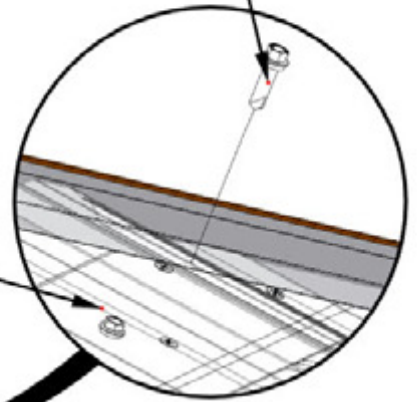

2847 (X1)  
RIDGE CAP CHANNEL LONG

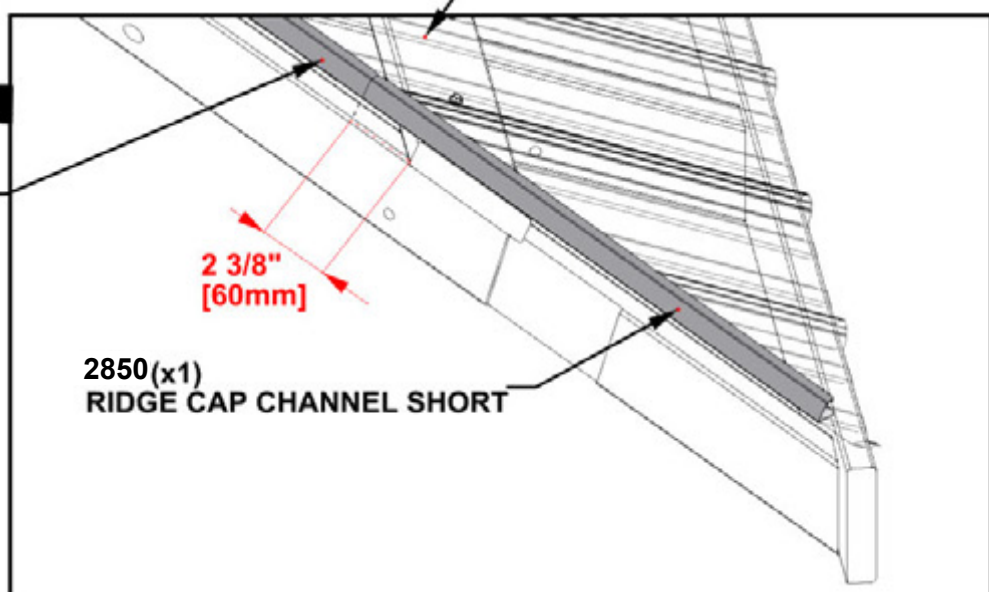

# STEP 34 - 12FT ROOF PANEL ASSEMBLY

Qty	PART NUMBER	DESCRIPTION
32	H100833	SCREW WOODGRIP 10-16x3/4

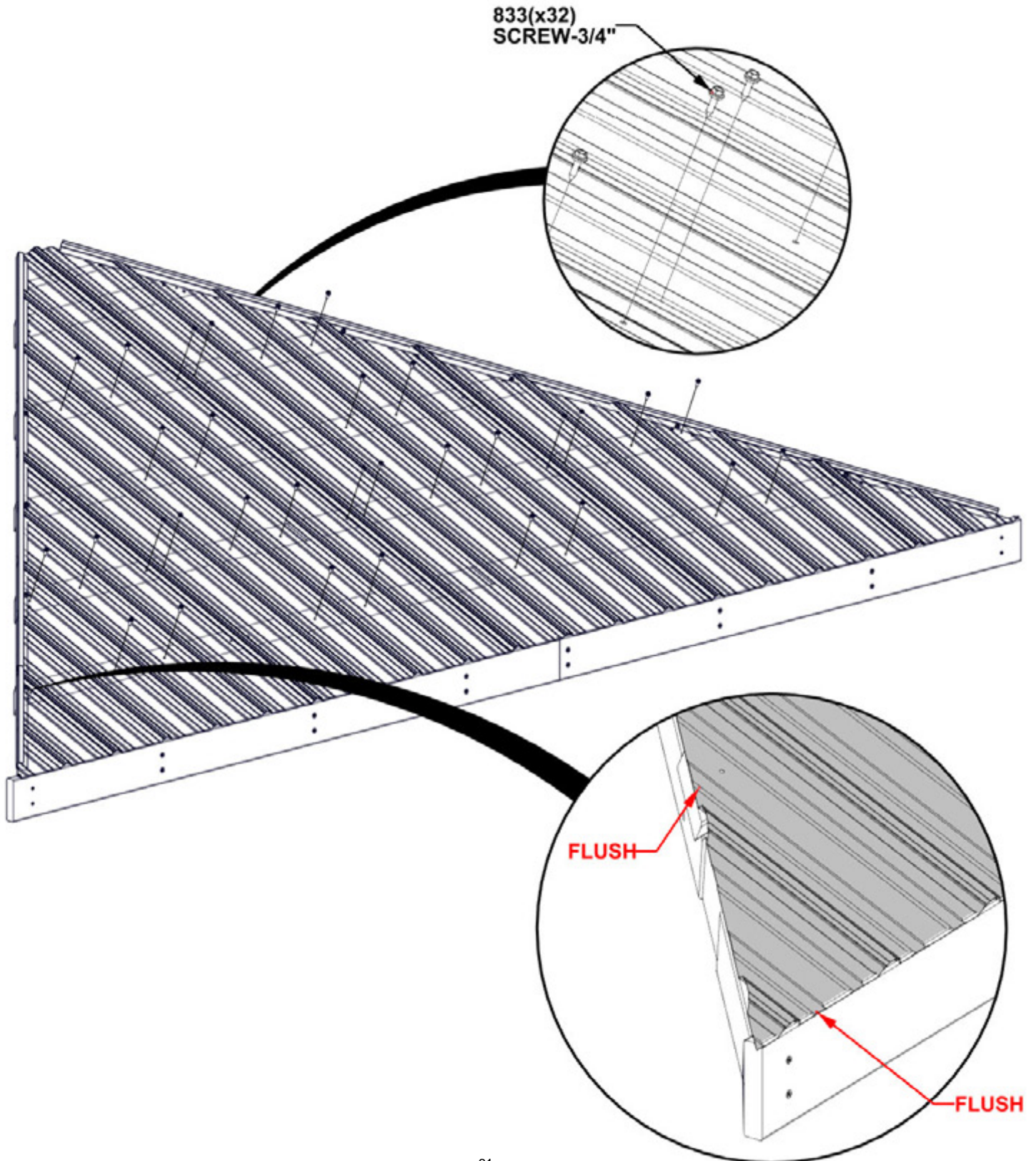

**REPEAT 12FT ROOF PANEL  
ASSEMBLY STEPS 27 THROUGH 34**

# STEP 35A - 12FT ROOF PANEL ATTACHMENT

## TIPS:

- THREE PEOPLE ARE HELPFUL FOR THIS STEP.
- POSITION A PERSON ON A LADDER IN THE CENTER OF THE GAZEBO TO HELP SUPPORT THE ROOF PANEL.
- WITH TWO PEOPLE, WORK THE PANEL UP WITHOUT SLIDING OR DRAGGING, UNTIL IT MEETS THE ROOF SUPPORT FRAME.
- MAKE SURE THE ROOF PANEL SLIDES UNDERNEATH THE RIDGE CAP.

**WARNING: GLOVES ARE RECOMMENDED WHEN HANDLING STEEL ROOF PIECES**

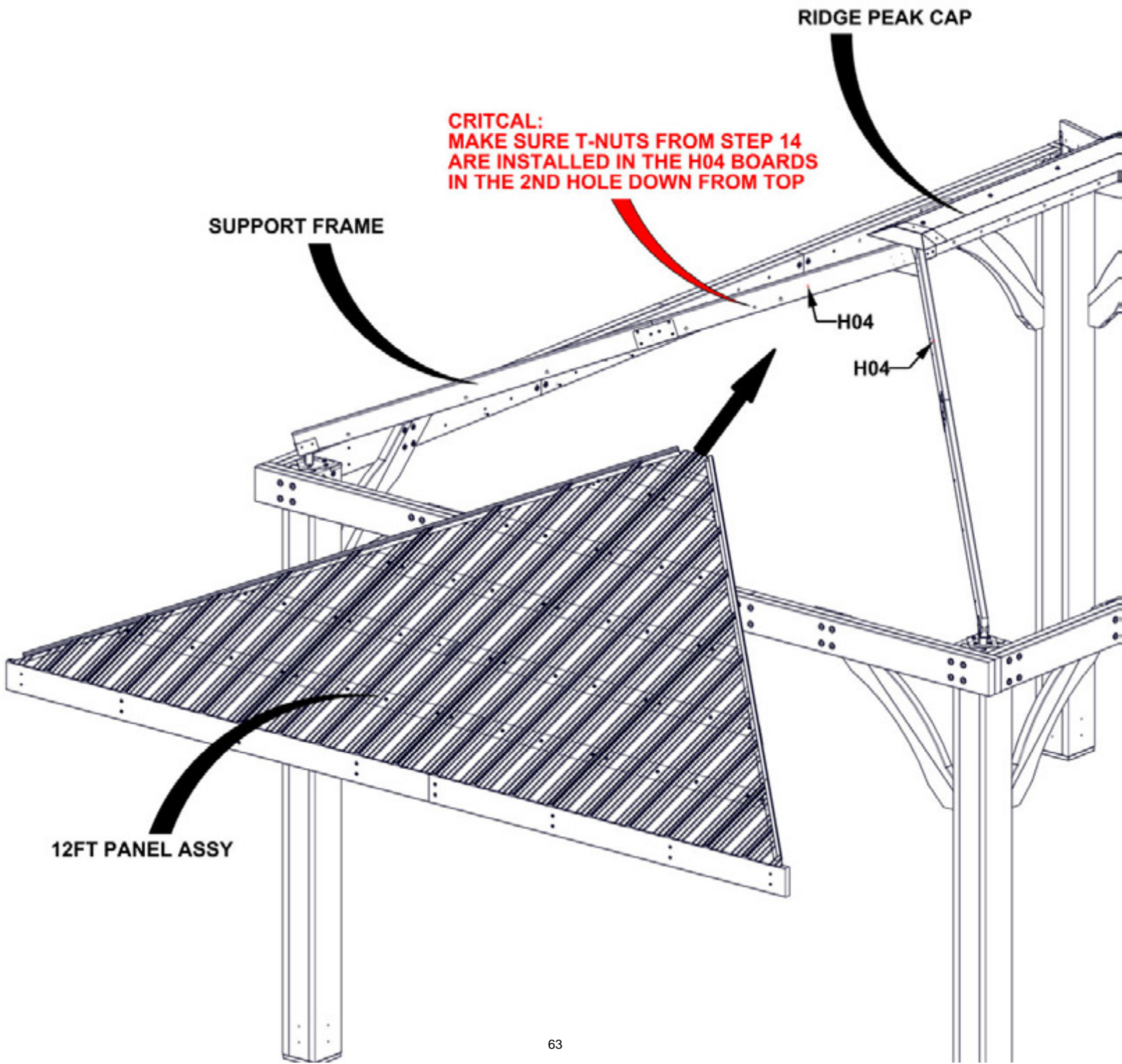

# STEP 35B - 12FT ROOF PANEL ATTACHMENT

Qty	PART NUMBER	DESCRIPTION
2	H100198	WASHER LOCK EXT 8X19 BLK
2	H100378	BOLT WH 5/16x1 3/4 BLK

- TIPS:
- IF NECESSARY, USE A LONG SCREWDRIVER OR CLAMPS TO HOLD PANELS IN PLACE.
  - INSERT BOLTS INTO THE FIRST HOLE FROM THE TOP OF THE H07/H08 BOARDS.

**HAND TIGHTEN ONLY**

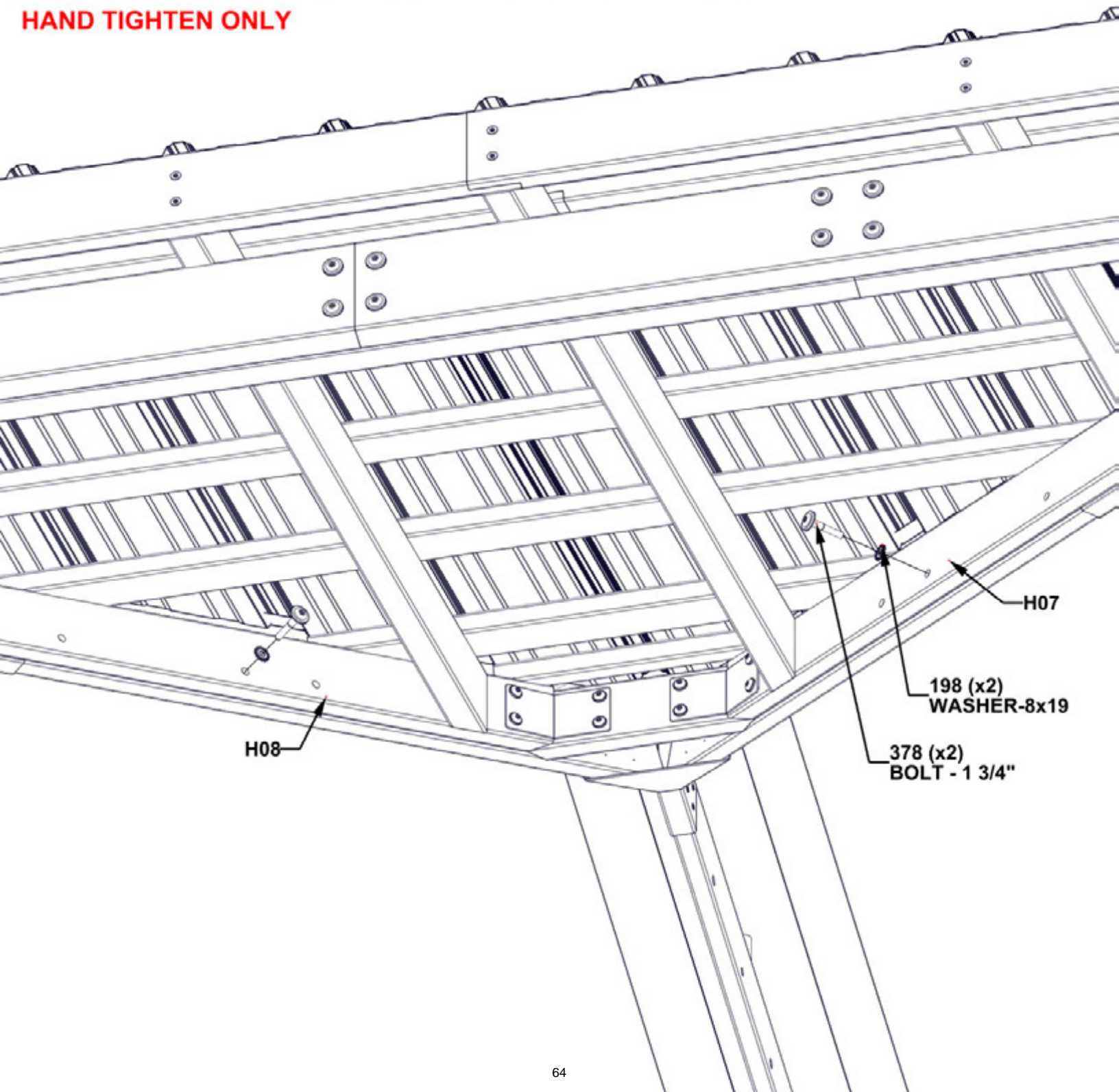

**REPEAT 12FT ROOF PANEL INSTALLATION  
STEPS 35A & 35B**

# STEP 36A - 16FT ROOF PANEL ATTACHMENT

## TIPS:

- THREE PEOPLE ARE HELPFUL FOR THIS STEP.
- POSITION A PERSON ON A LADDER IN THE CENTER OF THE GAZEBO TO HELP SUPPORT THE ROOF PANEL.
- WITH TWO PEOPLE, WORK THE PANEL UP WITHOUT SLIDING OR DRAGGING, UNTIL IT MEETS THE ROOF SUPPORT FRAME.
- MAKE SURE THE ROOF PANEL SLIDES UNDERNEATH THE RIDGE CAP.

**WARNING: GLOVES ARE RECOMMENDED WHEN HANDLING STEEL ROOF PIECES**

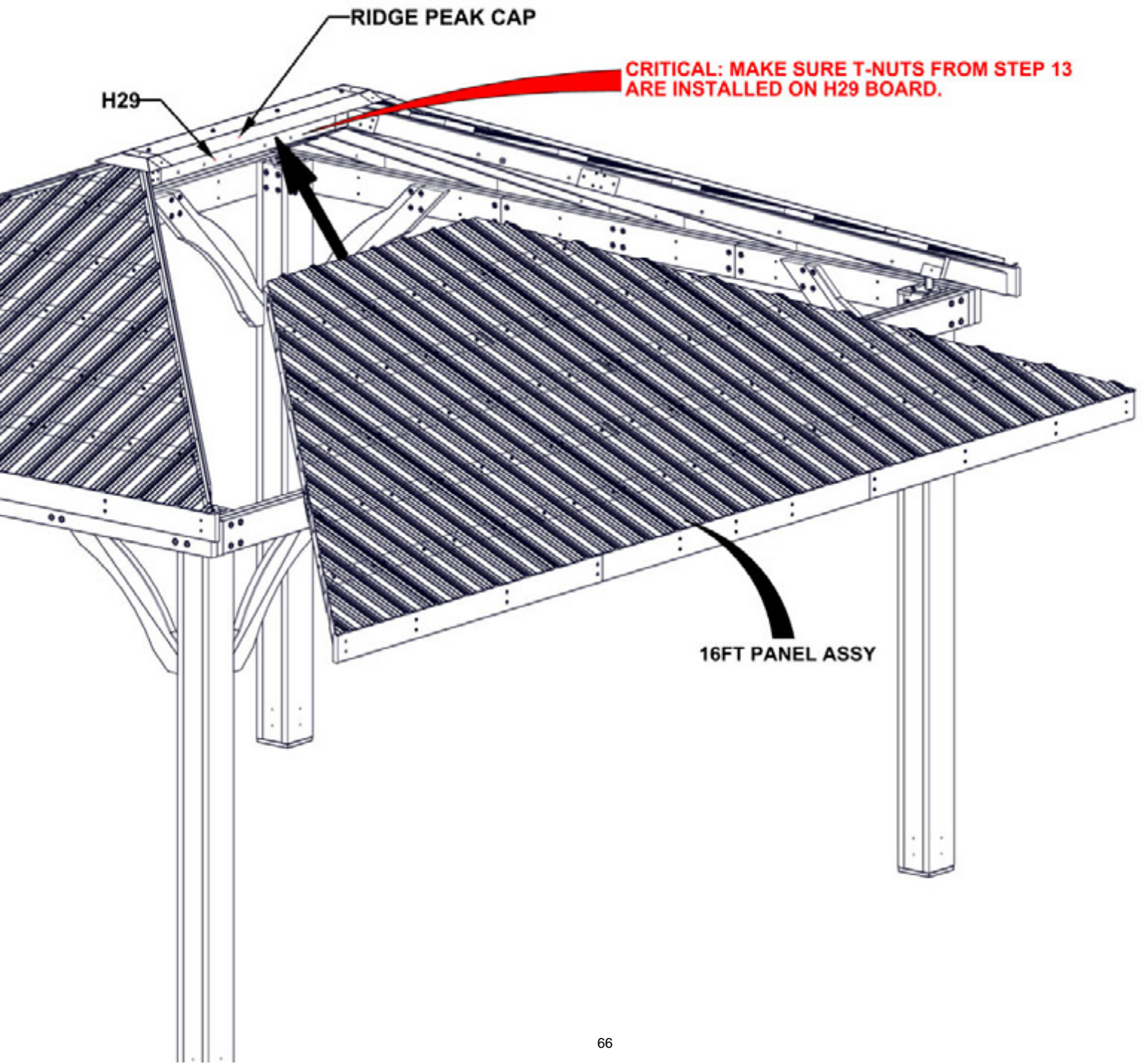

# STEP 36B - 16FT ROOF PANEL ATTACHMENT

Qty	PART NUMBER	DESCRIPTION
2	H100198	WASHER LOCK EXT 8X19 BLK
2	H100378	BOLT WH 5/16x1 3/4 BLK

TIP:  
- IF NECESSARY, USE A LONG SCREWDRIVER OR CLAMPS TO HOLD PANELS IN PLACE.

**HAND TIGHTEN ONLY**

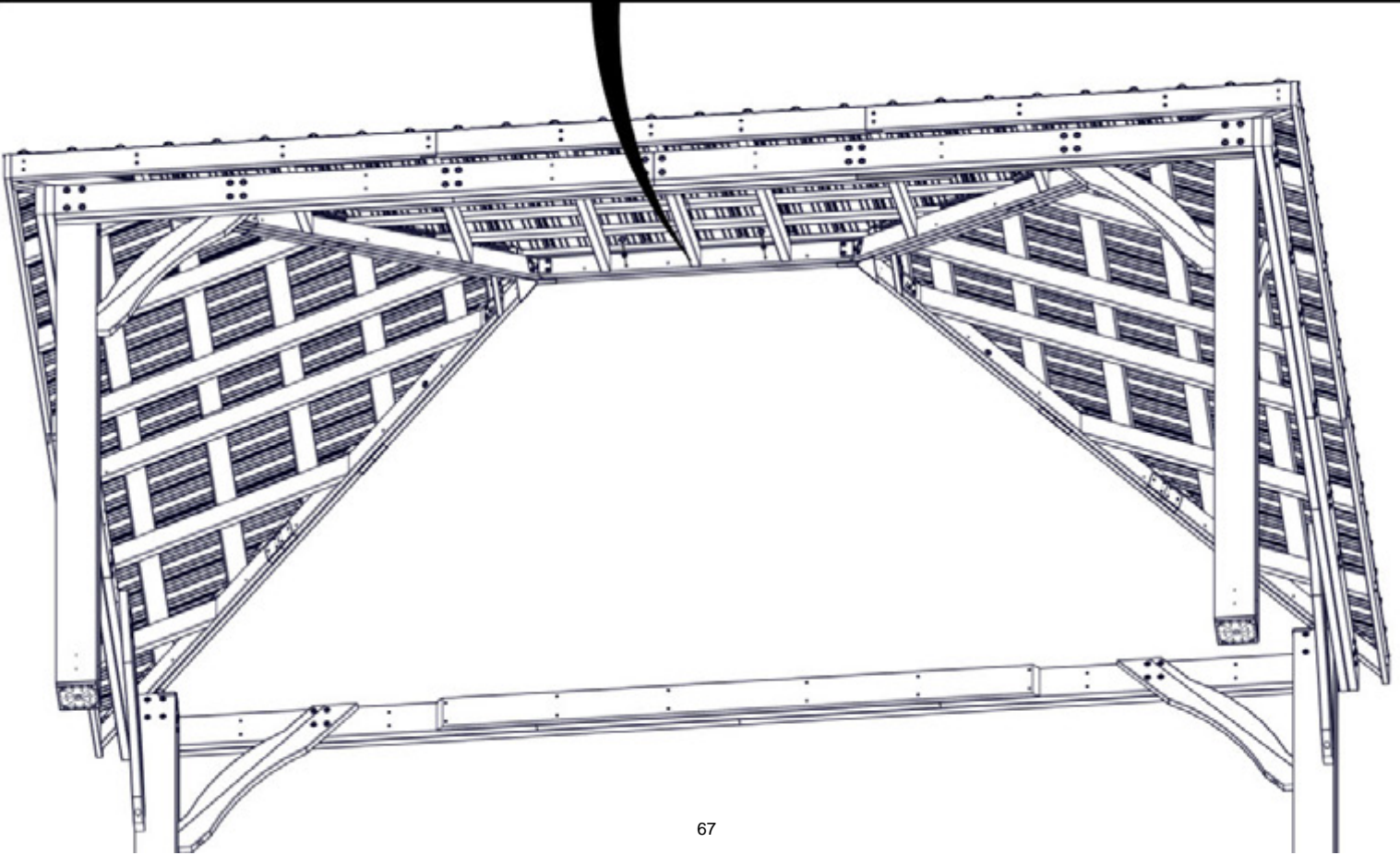
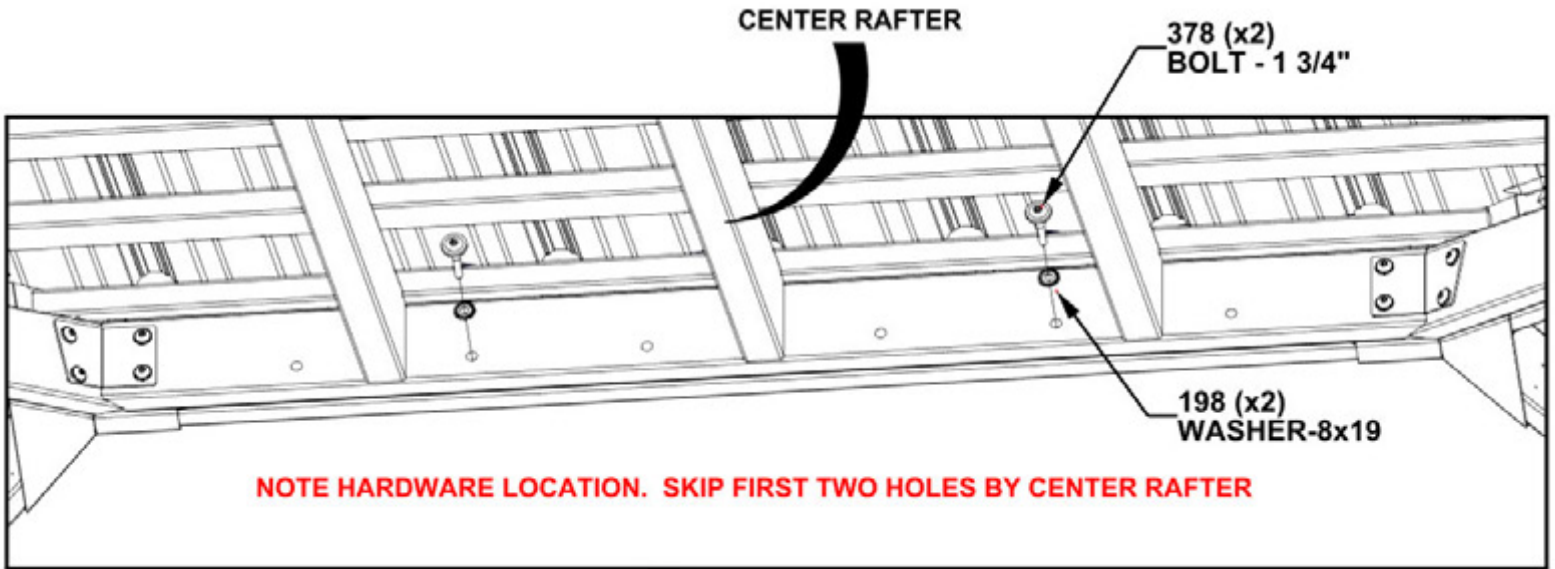

# STEP 37A - 16FT ROOF PANEL ATTACHMENT

Qty	PART NUMBER	DESCRIPTION
4	H100198	WASHER LOCK EXT 8X19 BLK
4	H100415	BOLT WH 5/16x3 3/4 BLK
4	H100479	LOCK NUT 5/16 BLK
4	H100770	WASHER FLAT 5/16 BLK

- TIPS:**
- REPEAT STEP 36A FOR SECOND 16FT PANEL.
  - IF NECESSARY USE A LONG SCREWDRIVER OR CLAMPS TO HOLD PANEL IN PLACE.

**HAND TIGHTEN ONLY**

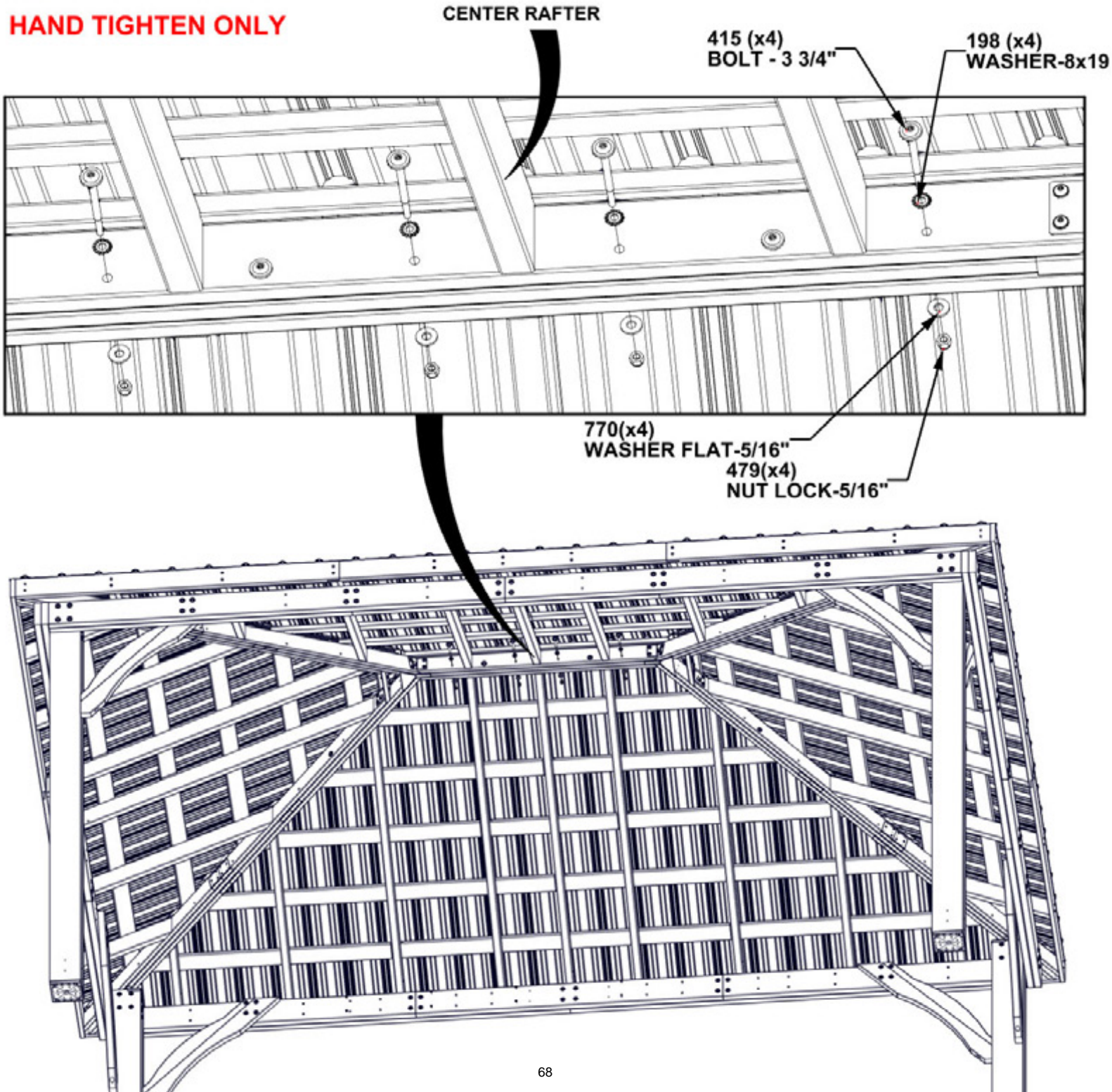

# STEP 37B - 16FT ROOF PANEL ATTACHMENT

Qty	PART NUMBER	DESCRIPTION
20	H100198	WASHER LOCK EXT 8X19 BLK
20	H100415	BOLT WH 5/16x3 3/4 BLK
20	H100479	NUT LOCK 5/16 BLK
20	H100770	WASHER FLAT 5/16 BLK

**HAND TIGHTEN ONLY**

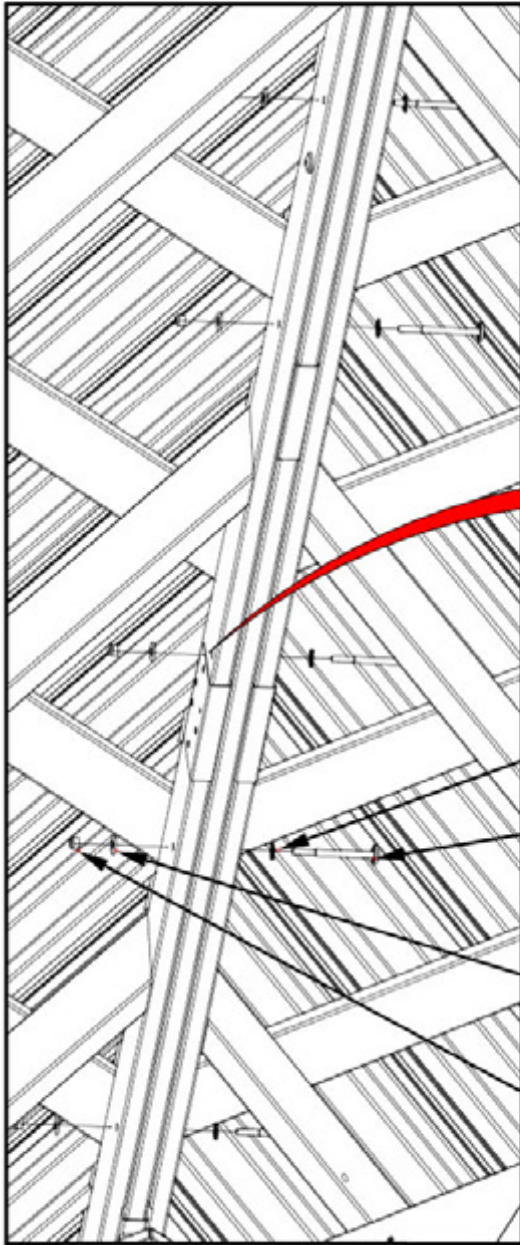

**IF THE HOLES ARE SLIGHTLY UNALIGNED, DRIVE THE BOLT THROUGH THE (3) BOARDS USING A DRILL. THIS WILL ENABLE THE BOLTS TO SCREW INTO THE HOLES.**

198 (x5)  
WASHER-8x19

415 (x5)  
BOLT - 3 3/4"

770(x5)  
WASHER FLAT-5/16"

479(x5)  
NUT LOCK-5/16"

**REPEAT ON ALL FOUR  
DIAGONAL ROOF JOIST**

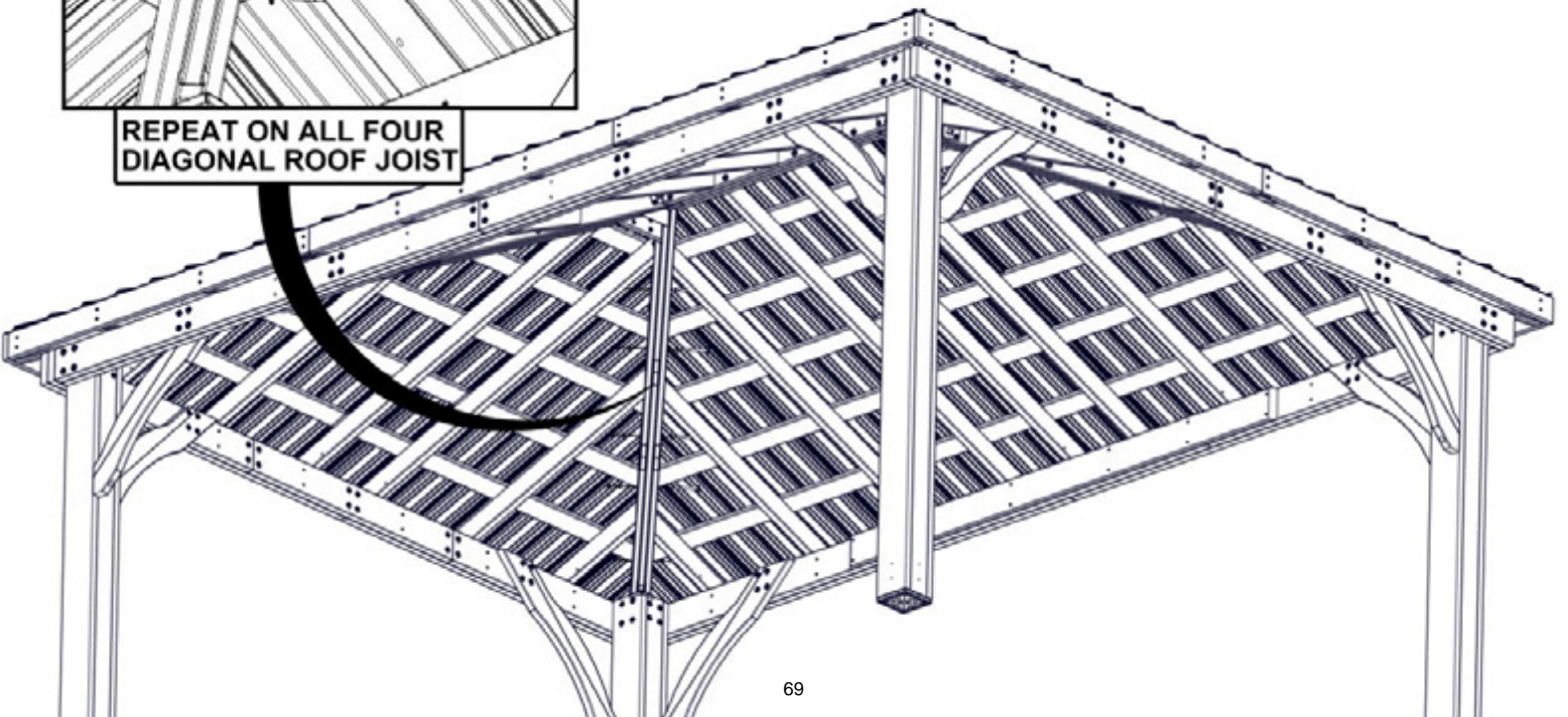

# STEP 38 - ROOF PANEL ATTACHMENT

**TIGHTEN ALL THE HARDWARE IN THE ORDER SHOW BELOW.  
START AT THE TOP AND WORK YOUR WAY DOWN**

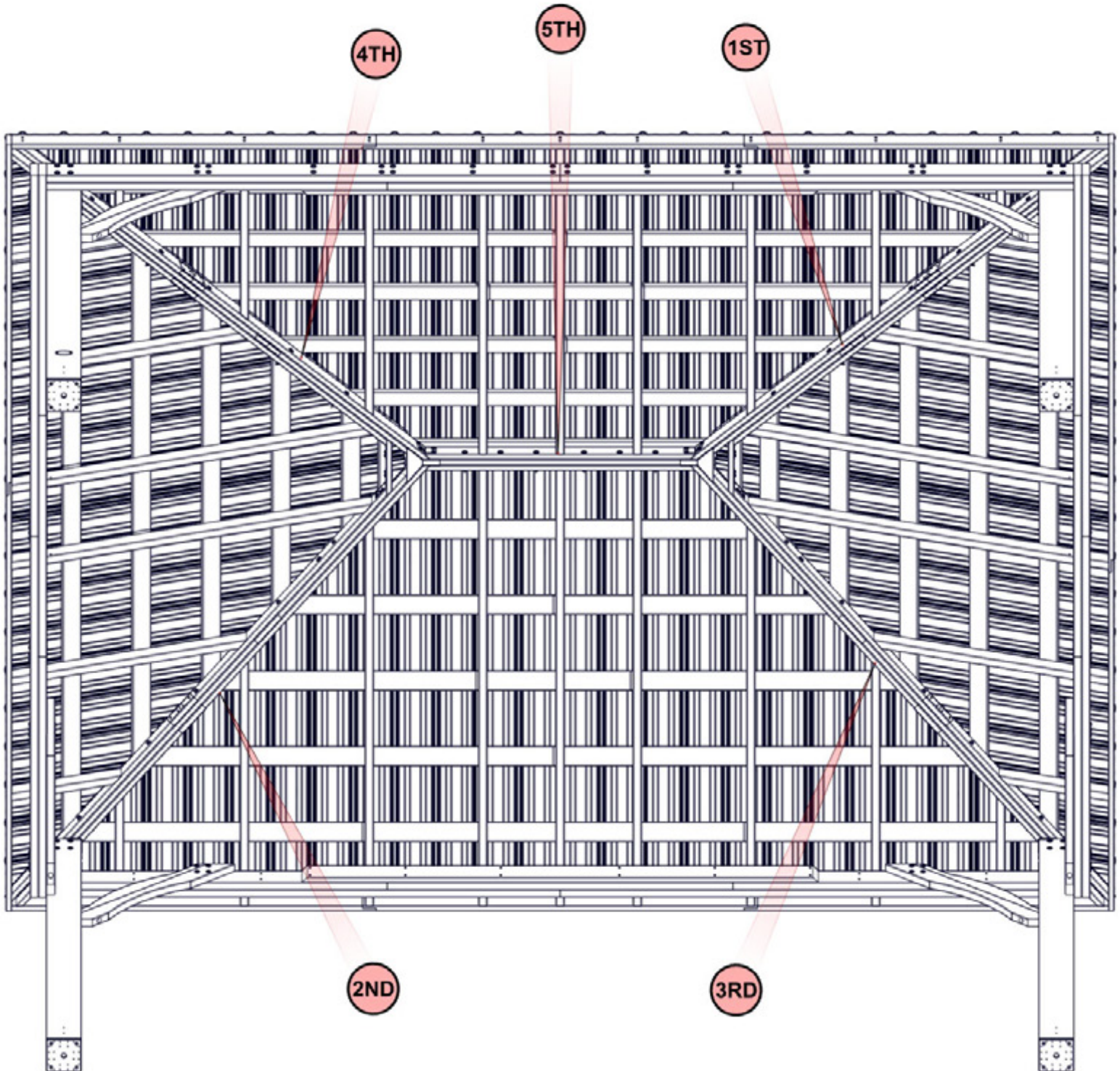

# STEP 39 - ROOF ASSEMBLY



A4M01752 | RAFTER CLIP  
(18)

Qty	PART NUMBER	DESCRIPTION
18	H100488	BOLT WH 1/4x2 BLK
36	H100536	SCREW PWH 8x1 1/4 BLK
18	H100630	WASHER FLAT 8x19 BLK
18	H100653	NUT LOCK 1/4 BLK

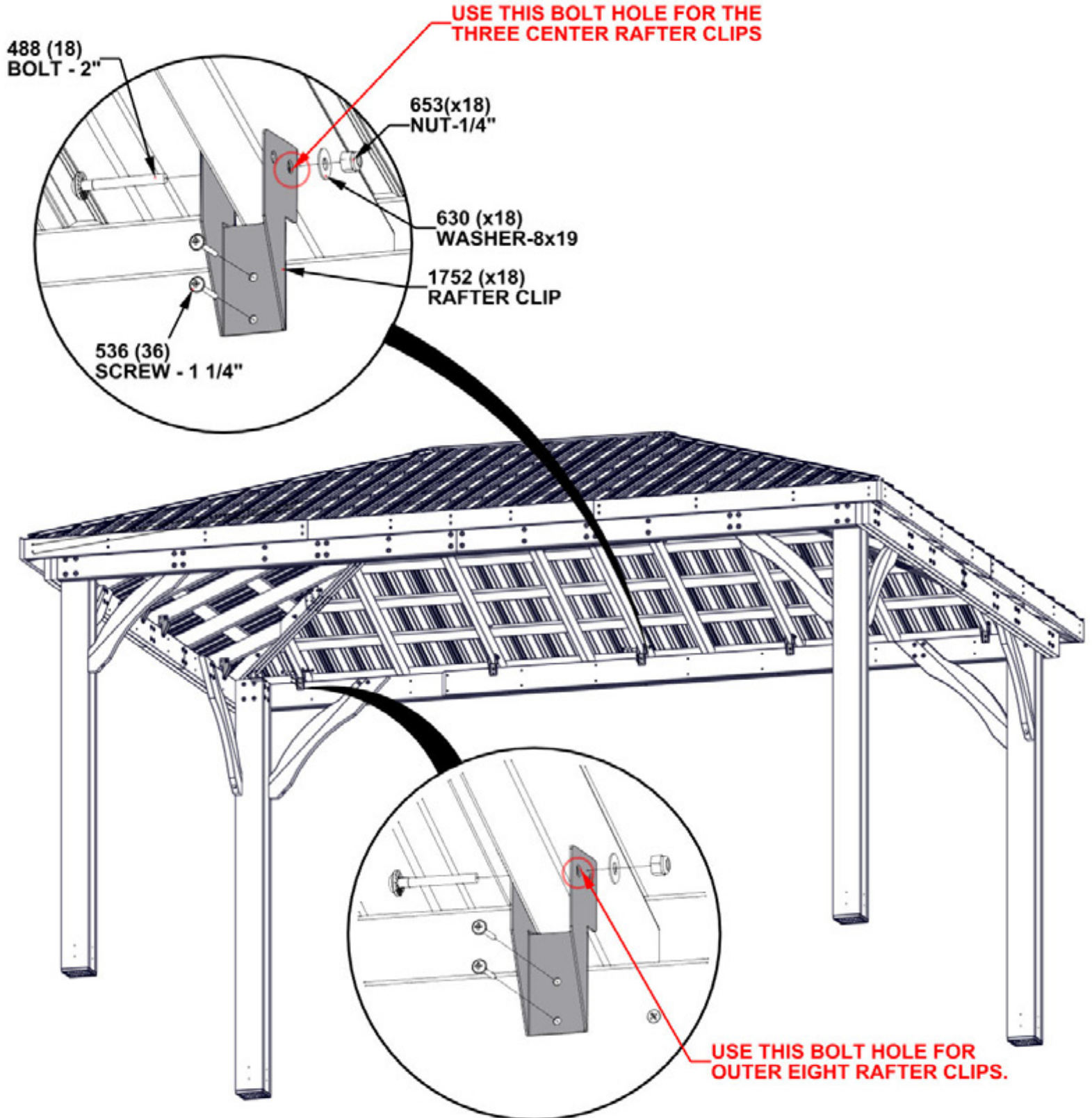

# STEP 40 - ROOF ASSEMBLY



Qty	PART NUMBER	DESCRIPTION
16	H100392	SCREW PWH 8x3/4 BLK

A4M01185  
(4) CORNER BRACKET

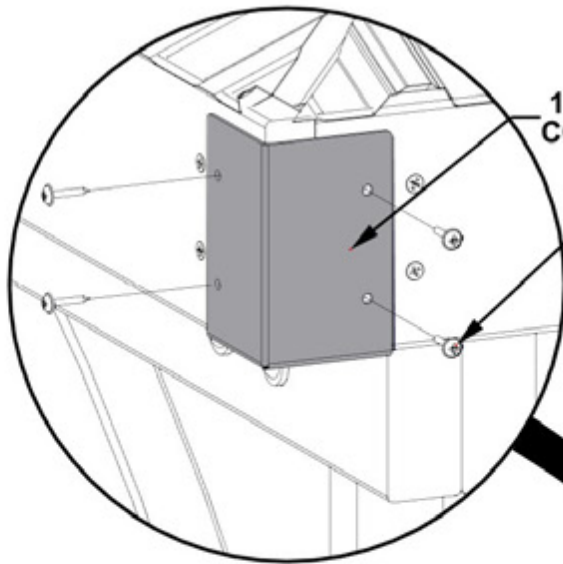

1185(x4)  
CORNER BRACKET

**REPEAT ON ALL FOUR CORNERS**

392 (x4)  
SCREW - 3/4"

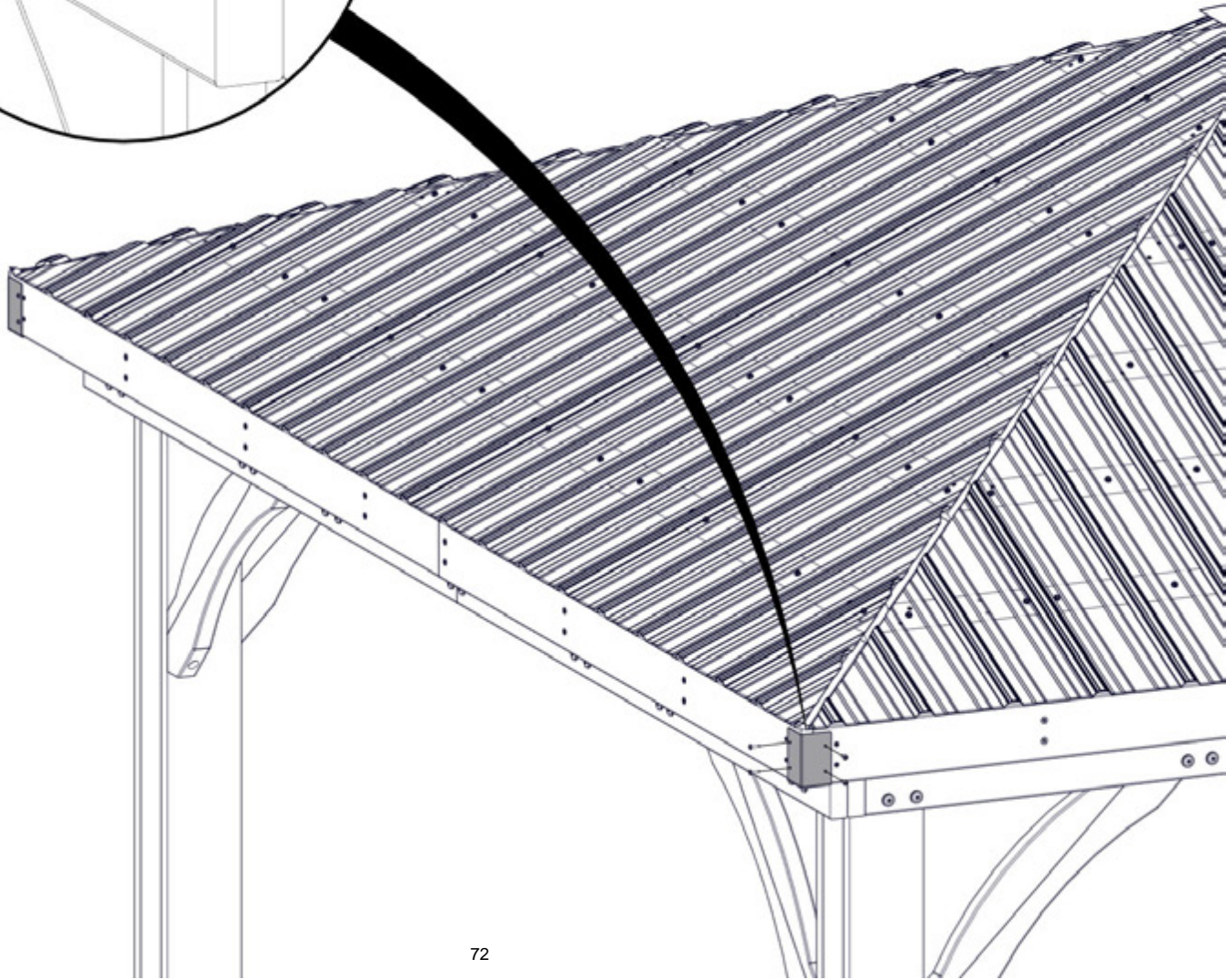

# STEP 41 - 12FT ROOF TRIM



A4M02821 | EDGE TRIM LONG  
(4)

Qty	PART NUMBER	DESCRIPTION
26	H100759	SCREW SELF TAPPING 1/4x1



A4M02869 | EDGE TRIM SHORT  
(2)



A4M02822 | EDGE TRIM SPLICE  
(4)



A4M02825 | EDGE TRIM CORNER SPLICE  
(4)

- TIPS:**
- START ON THE LEFT SIDE OF A 16FT PANEL.
  - SLIDE EDGE TRIM PIECES TOGETHER AS SHOWN BELOW.
  - MAKE SURE ALL PANELS ARE COVERED BEFORE INSTALLING SCREWS.
  - INSTALL H100759 AS SHOWN.

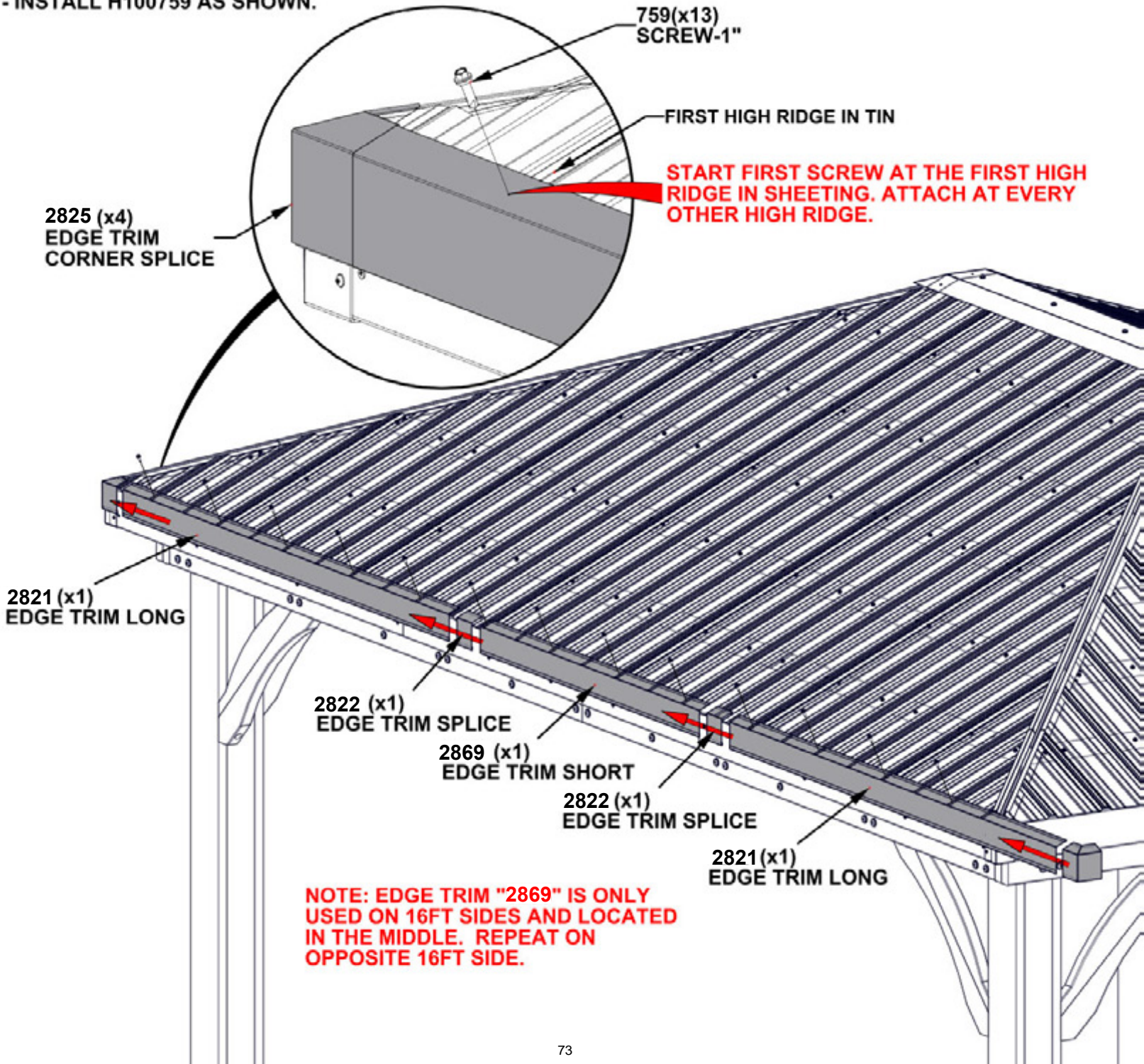

# STEP 42 - 12FT ROOF TRIM

Qty	PART NUMBER	DESCRIPTION
20	H100759	SCREW SELF TAPPING 1/4x1



A4M02821 | EDGE TRIM LONG  
(4)

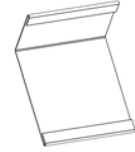

A4M02822 | EDGE TRIM SPLICE  
(2)

## TIPS"

- START ON THE LEFT SIDE OF A 12FT PANEL.
- SLIDE EDGE TRIM PIECES TOGETHER AS SHOWN BELOW.
- MAKE SURE ALL PANELS ARE COVERED BEFORE INSTALLING SCREWS.
- INSTALL H100759 SCREWS AS SHOWN.

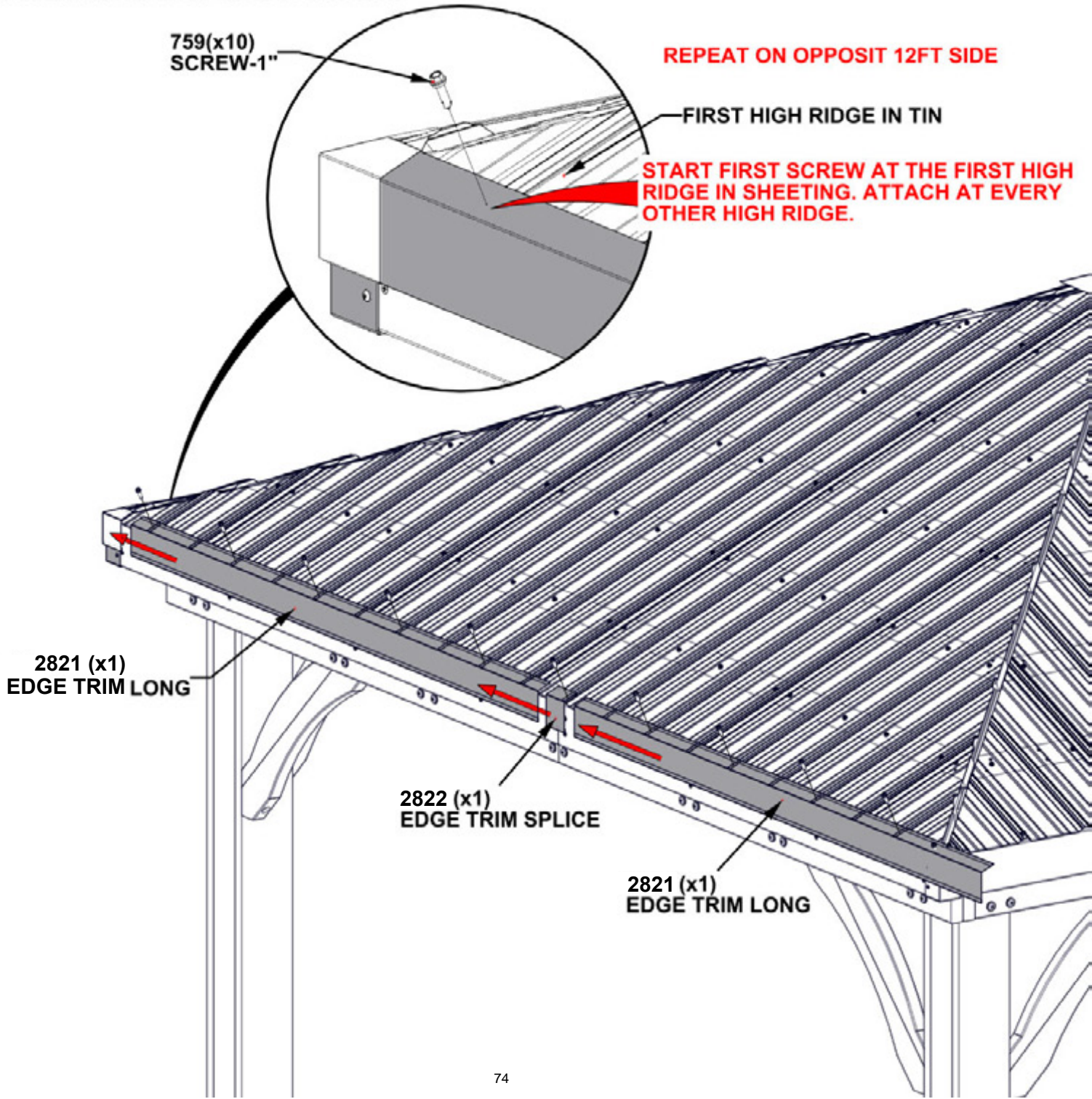

# STEP 43 - ROOF ASSEMBLY

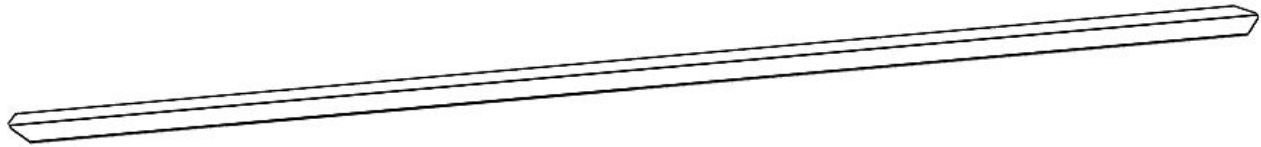

A4M02826 | CORNER RIDGE CAP LONG  
(4)

## TIPS:

- SLIDE CORNER RIDGE CAP ONTO ROOF RIDGE CAP CHANNEL AS SHOWN.
- DO NOT PUSH ALL THE WAY TO THE TOP. FLUSH WITH CORNER OF GAZEBO AS SHOWN.
- REPEAT ON ALL CORNERS.

**REPEAT ON ALL FOUR CORNERS**

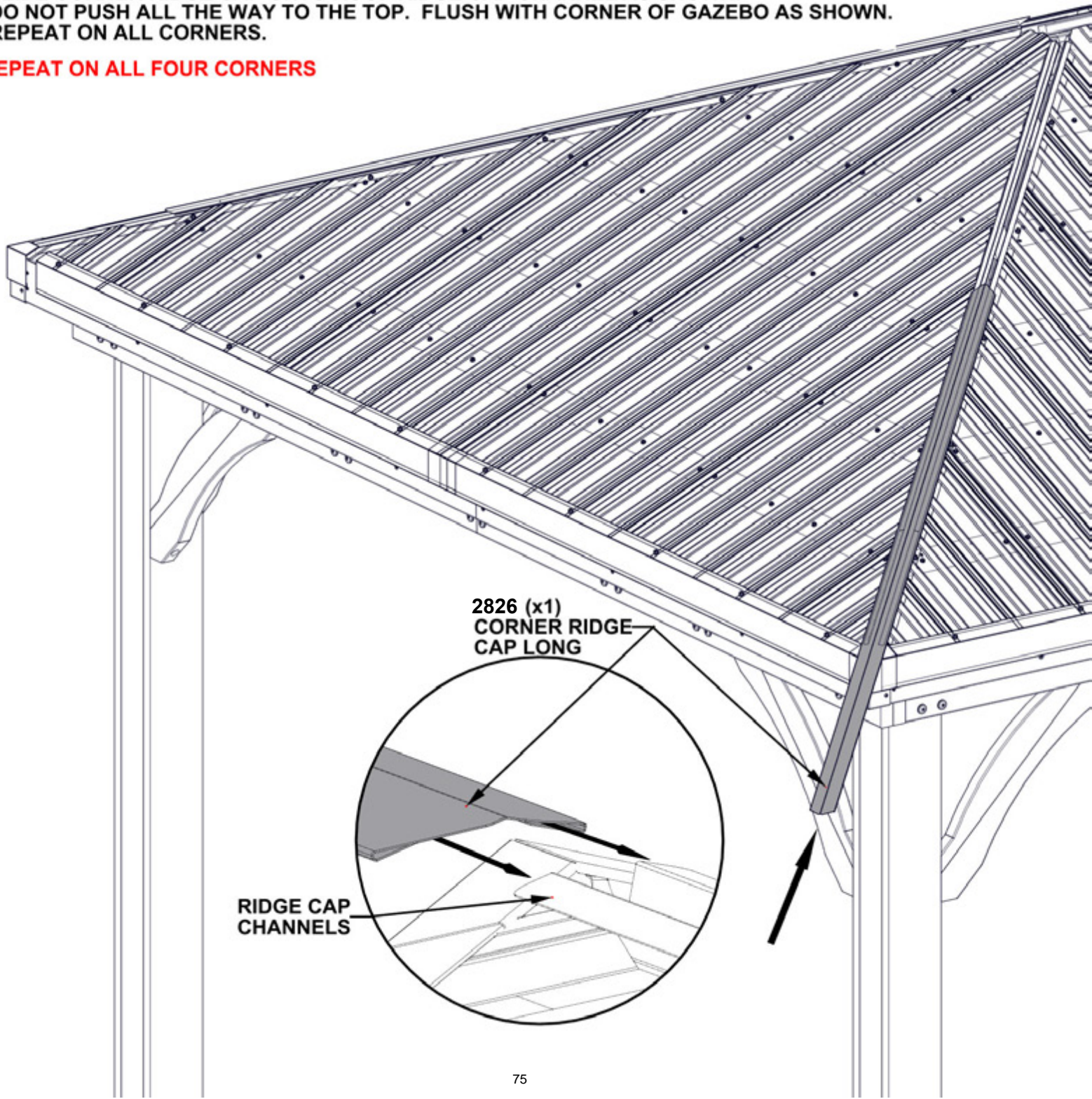

2826 (x1)  
CORNER RIDGE  
CAP LONG

RIDGE CAP  
CHANNELS

# STEP 44 - ROOF ASSEMBLY



A4M02867 | RIDGE CAP SPLICE ASSEMBLY  
(4)

REPEAT ON ALL FOUR CORNERS

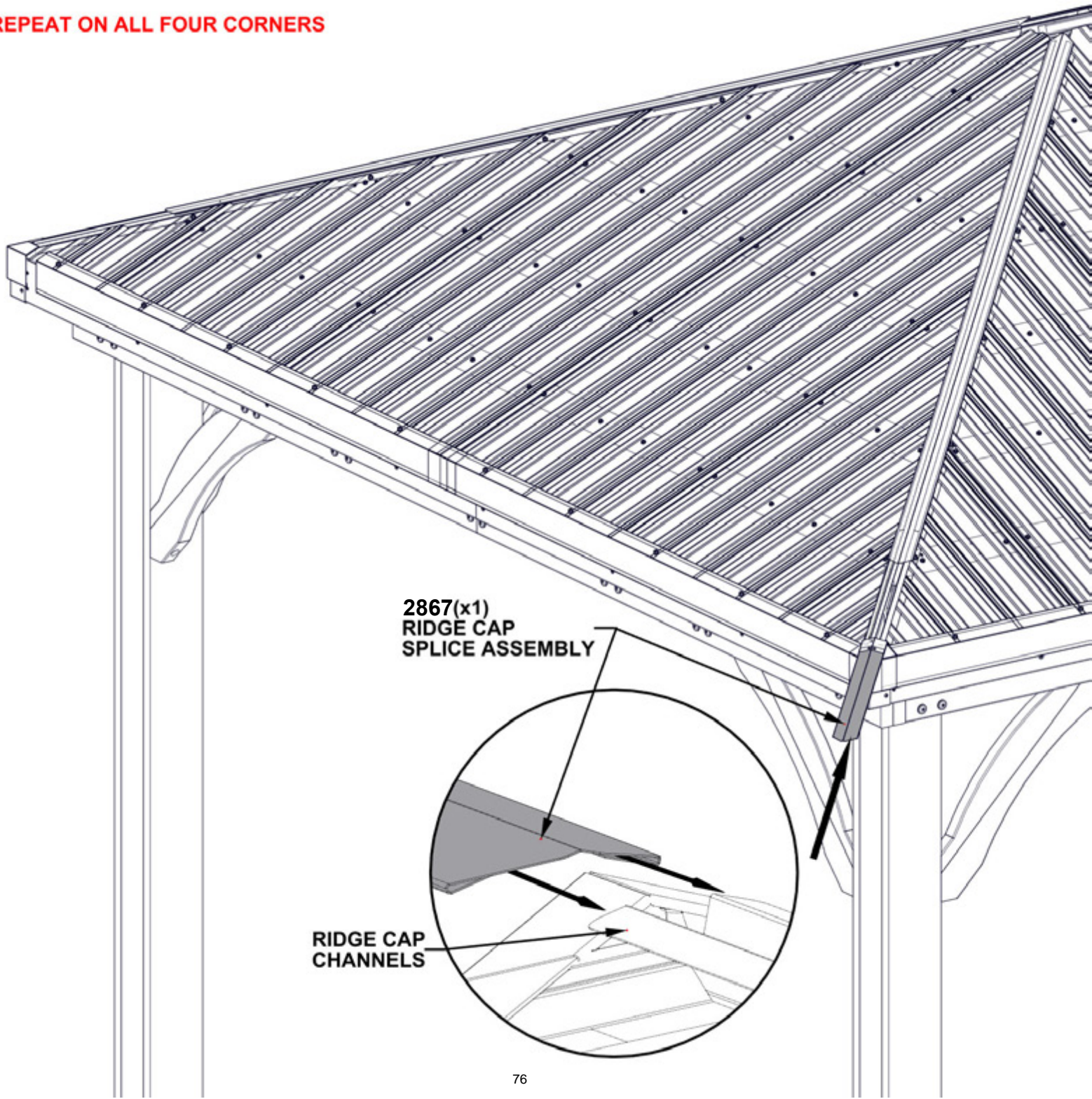

2867(x1)  
RIDGE CAP  
SPLICE ASSEMBLY

RIDGE CAP  
CHANNELS

# STEP 45 - ROOF ASSEMBLY

Qty	PART NUMBER	DESCRIPTION
12	H100759	SCREW SELF TAPPING 1/4x1

**REPEAT ON ALL FOUR CORNERS**

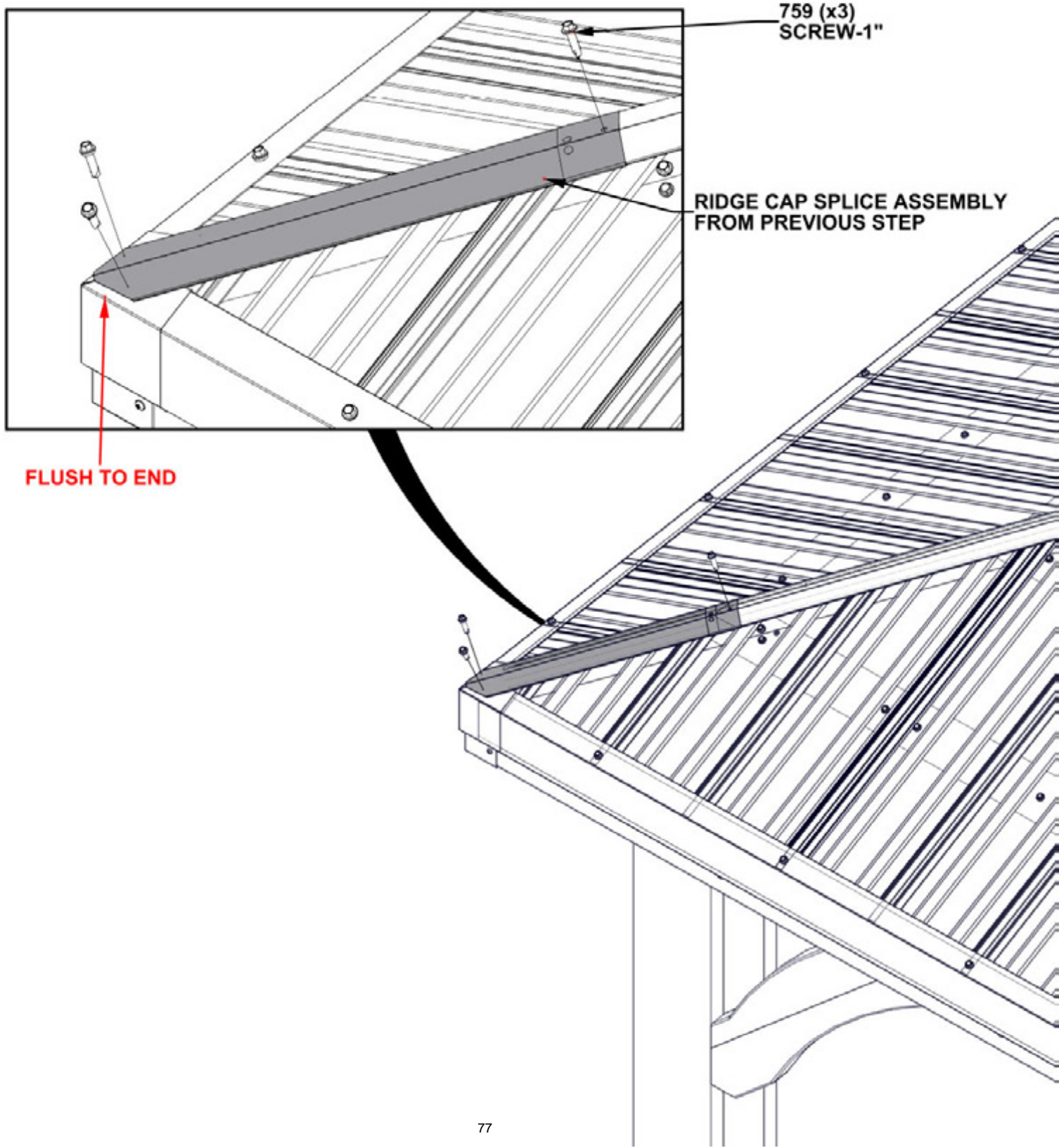

# STEP 46 - GAZEBO ASSEMBLY

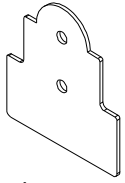

A4M01794  
(8) STEEL POST PLATE

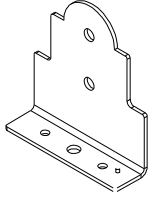

A4M01793  
(8) STEEL POST ANCHORING PLATE

Qty	PART NUMBER	DESCRIPTION
32	H100471	LAG SCREW WH 5/16x1 1/2 BLK

- TIPS:**
- ALL 950 STEEL POST PLATES GO ON THE INSIDES OF THE POST AS SHOWN.
  - ALL 949 STEEL POST ANCHORING PLATES GO ON THE OUTSIDES OF THE POST AS SHOWN

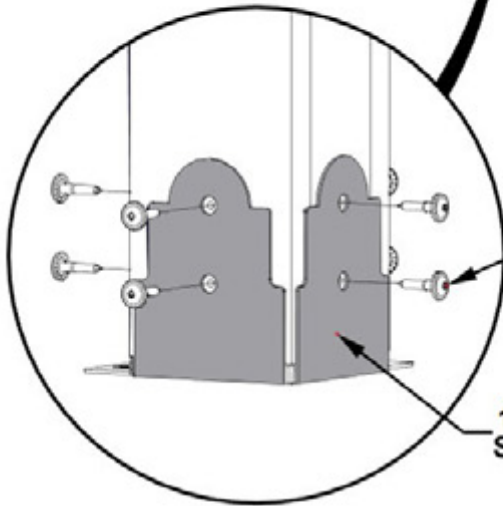
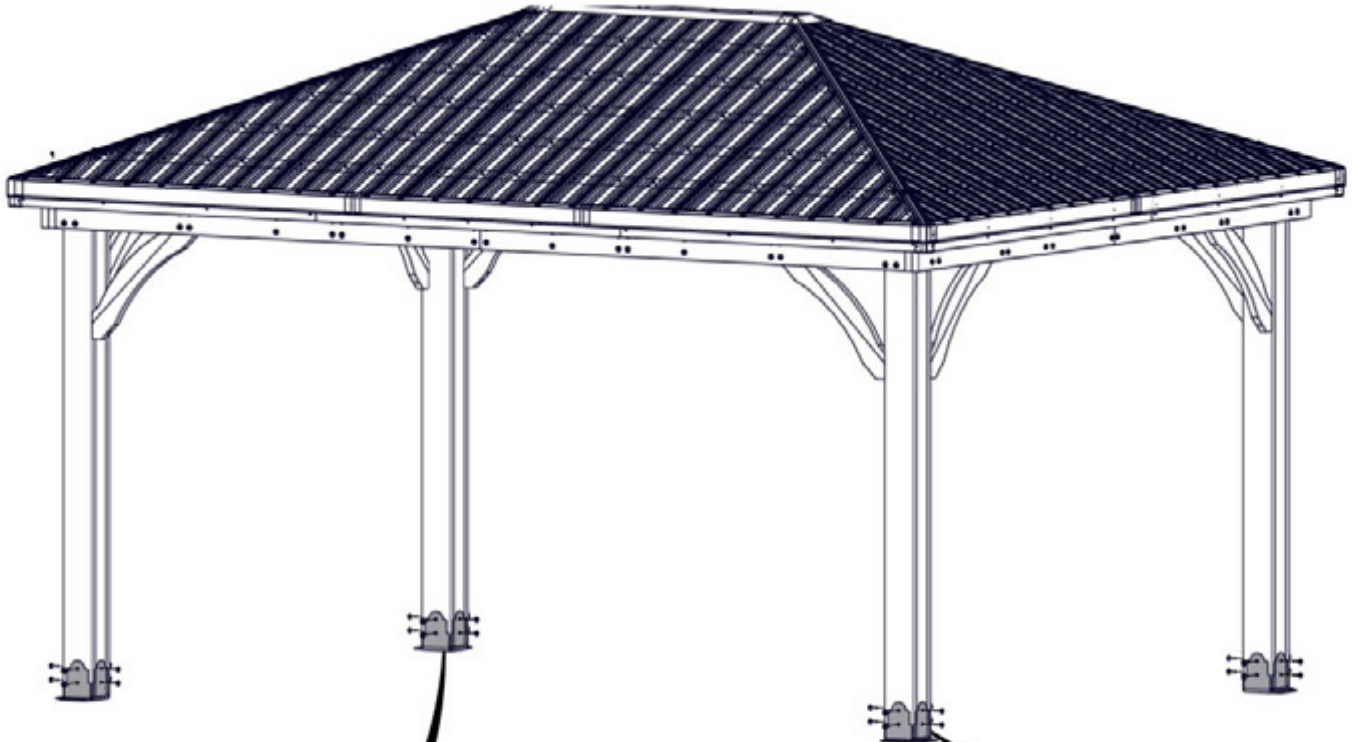

471 (x32)  
LAG SCREW - 1 1/2"

1794 (x8)  
STEEL POST PLATE

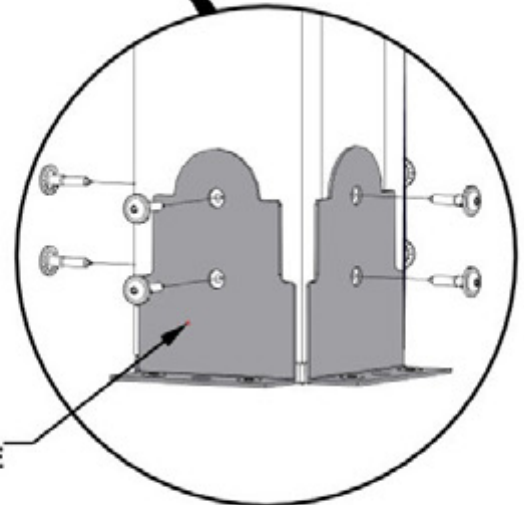

1793 (x8)  
STEEL POST ANCHOR PLATE

# STEP 47 - GAZEBO ASSEMBLY



QTY	PART NUMBER	DESCRIPTION
4	H100536	SCREW PWH 8x1 1/4 BLK

A4M02158  
BYD ID TAG PATIO  
(x1)

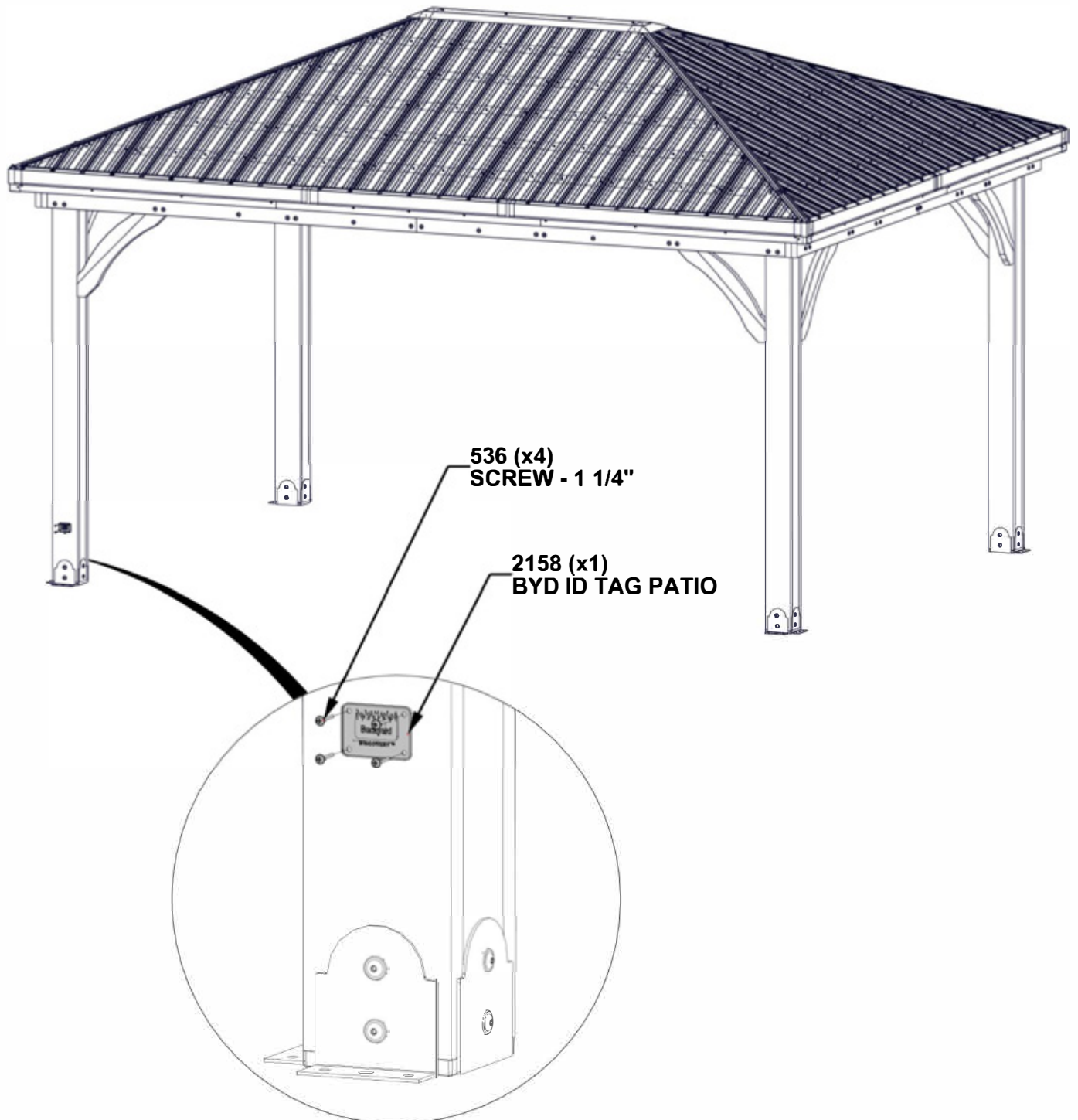

# STEP 48 - GAZEBO ASSEMBLY

Qty	PART NUMBER	DESCRIPTION
16	H100120	CONCRETE ANCHOR 1/4"x2"
16	H100630	WASHER FLAT 8x19 BLK

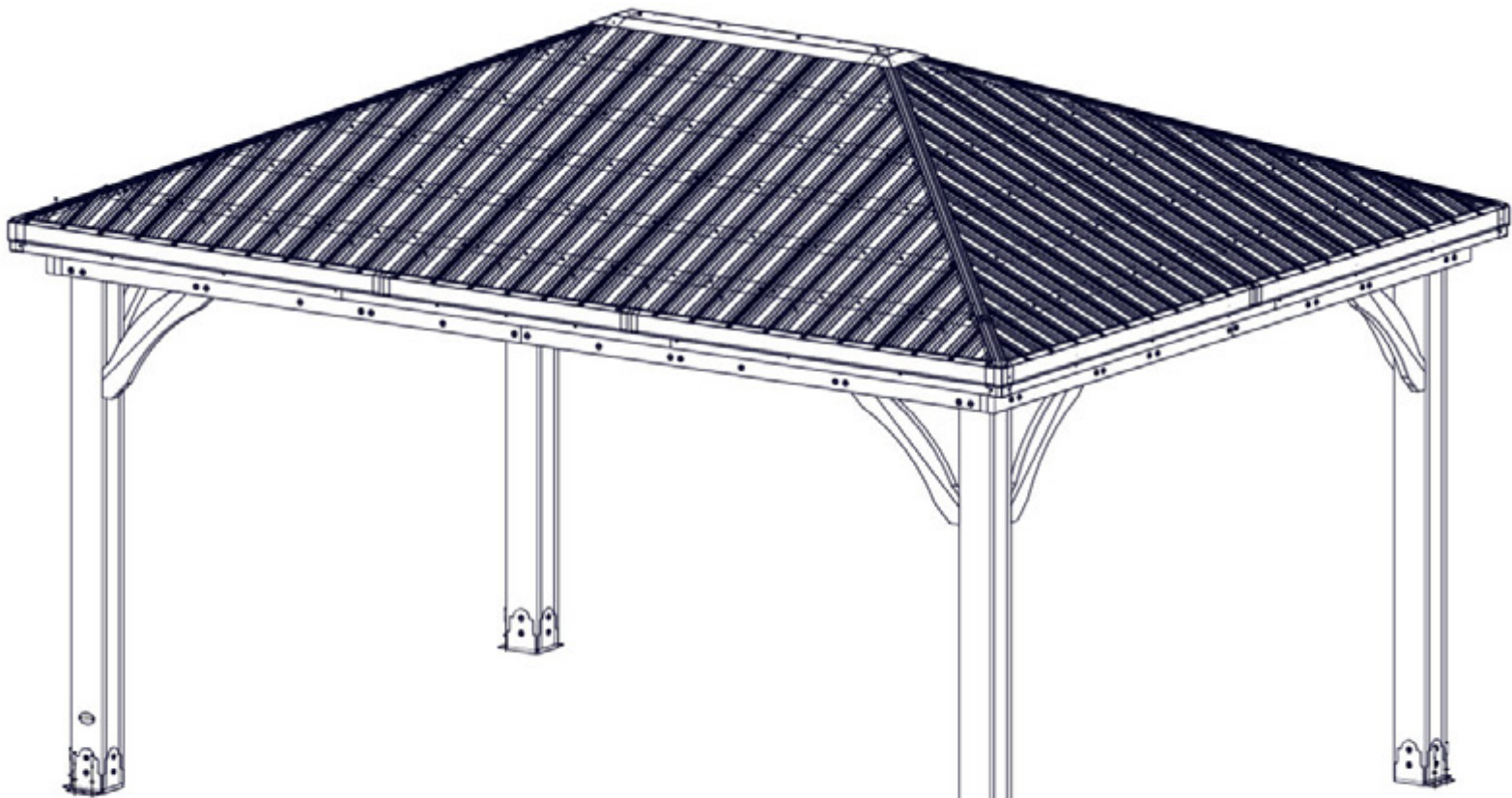

120 (x16)  
CONCRETE SCREW

630 (x16)  
WASHER-8x19

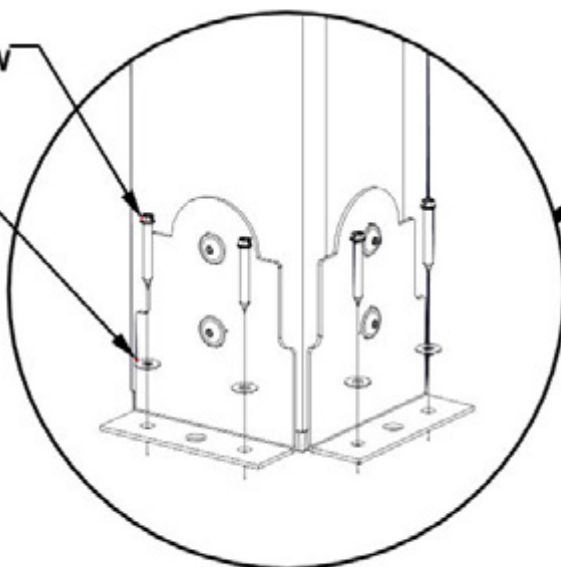

# STEP 49 - GAZEBO ASSEMBLY (OPTIONAL)

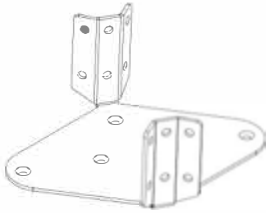

A4M02501 FAN MOUNT BRACKET  
(x1)

QTY	PART NUMBER	DESCRIPTION
4	H100382	SCREW PFH 8x1 3/4 BLK

- ATTACH YOUR ELECTRICAL BOX (SOLD SEPERATELY) WITH THE PROVIDED HOLES IN FAN MOUNT BRACKET.
- PLACE FAN MOUNT BRACKET ON RIDGE BEAMS AND MOVE TO DESIRED FAN LOCATION.
- ROTATE BRACKET UNTIL MOUNTING FLANGES ALIGN BEST WITH RIDGE BEAMS.
- USE AN 1/8" (3mm) DRILL BIT AND DRILL PILOT HOLES AND ATTACH AS SHOWN.

RIDGE BEAM

382 (x4)  
SCREW - 1 3/4"

2501 (x1)  
FAN MOUNT BRACKET

ELECTRICAL BOX NOT INCLUDED

HARDWARE BY OTHERS

FAN MOUNT BRACKET

ELECTRICAL BOX NOT INCLUDED

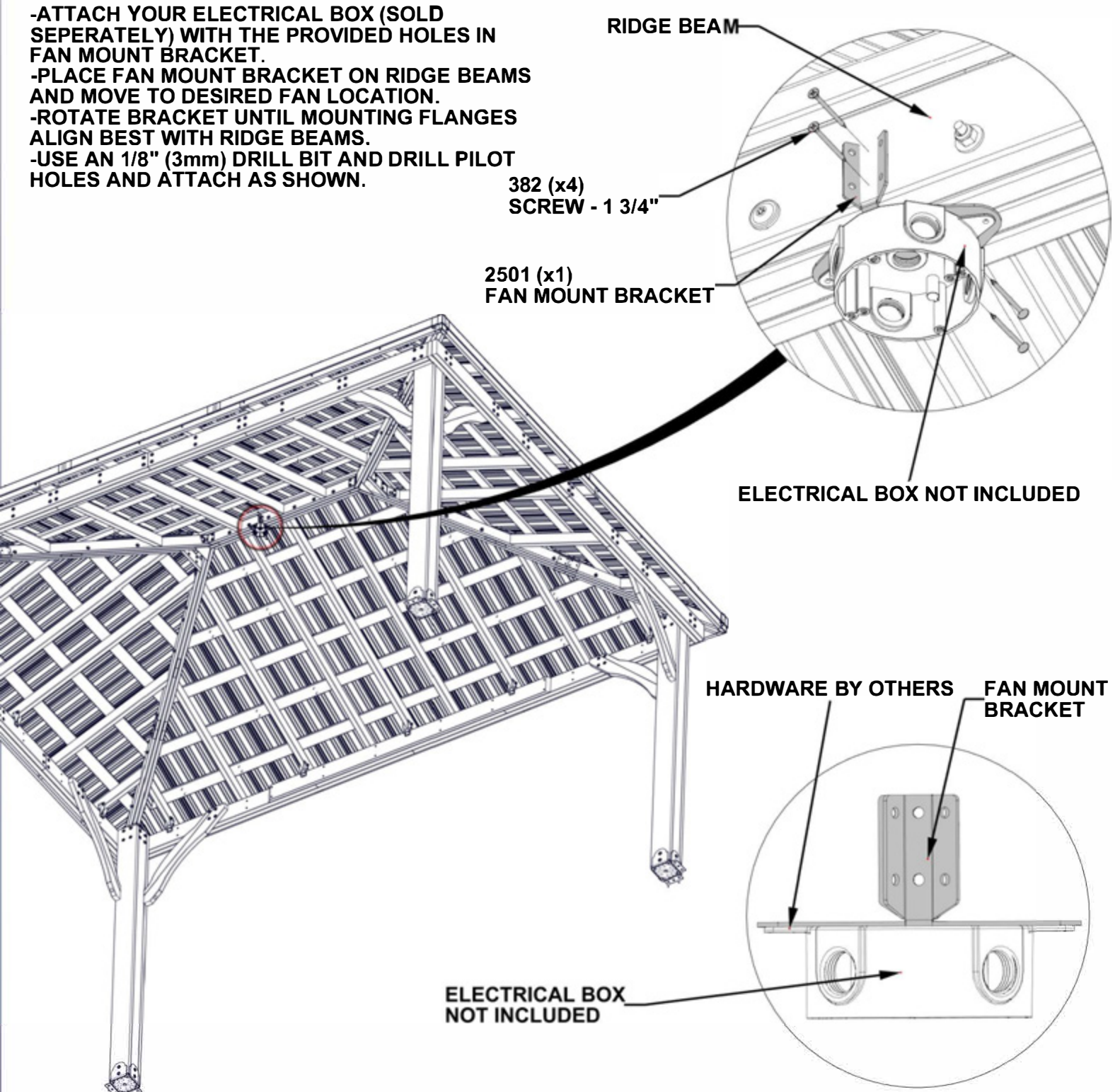

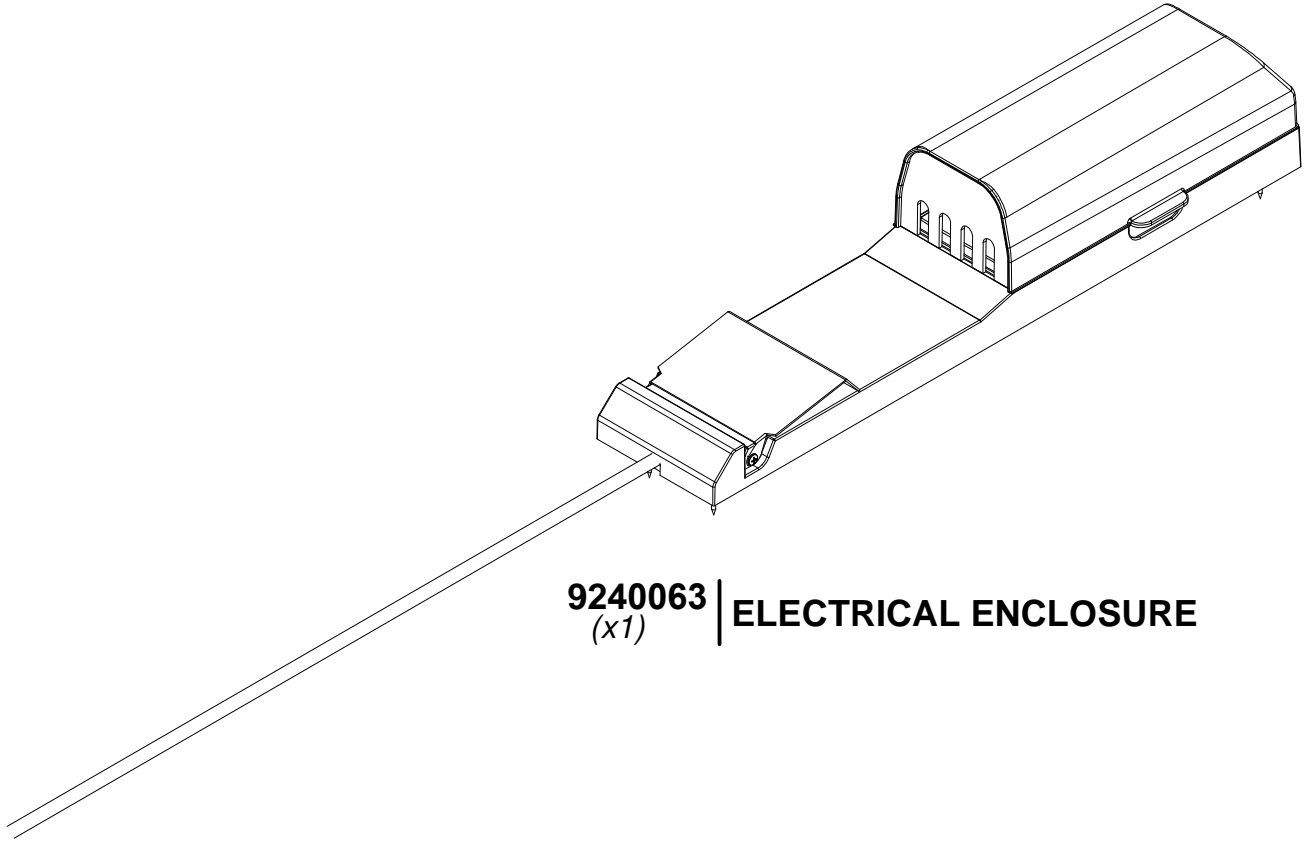

**9240063** | **ELECTRICAL ENCLOSURE**  
*(x1)*

**FOR POWERPORT INSTALLATION REFER TO ASSEMBLY INSTRUCTIONS THAT COME PACKAGED WITH THE POWERPORT KIT. INSTALL ON ANY POST THAT IS DESIRED. FOLLOW DIRECTIONS FOR PROPER INSTALLATION.**