

Assembly Instructions



CONSOLE TABLE

Thank you for purchasing this quality product. Be sure to check all packing materials carefully for small parts, which may have come loose inside the carton during shipment. Identify and count all items and compare with the PARTS LIST and/or HARDWARE LIST shown below.

Caution: Please read the instructions thoroughly before assembly.

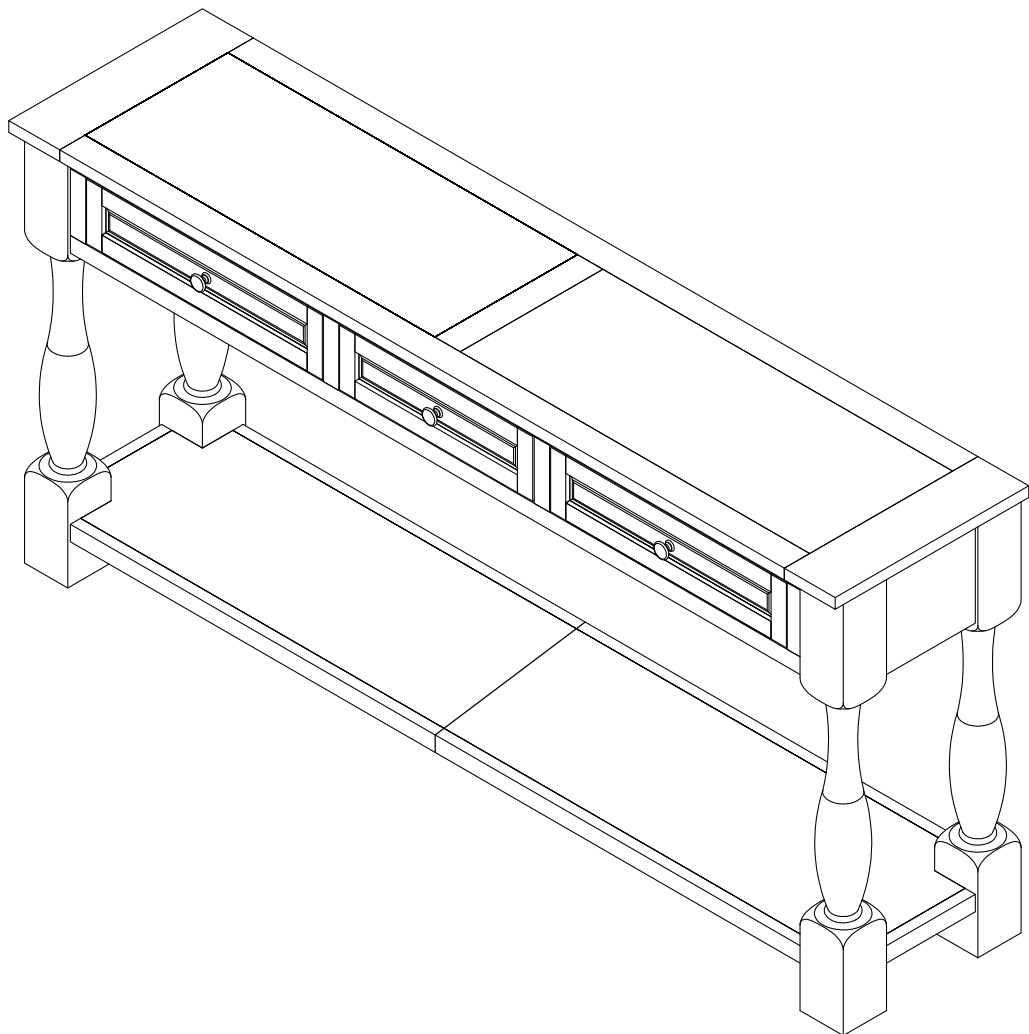

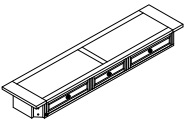

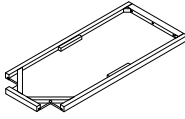
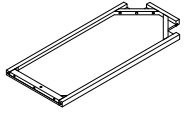
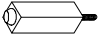
1. We recommend that you assemble this product with the assistance of another person; this will make the assembly easier, and will help eliminate damage to the product or injury to persons during assembly.
2. Please do not over tighten screws or bolts until the assembly is completed.
3. Please put all parts on a non-abrasive floor before assembly, and follow the assembly steps to assemble your newly purchased product correctly and efficiently.

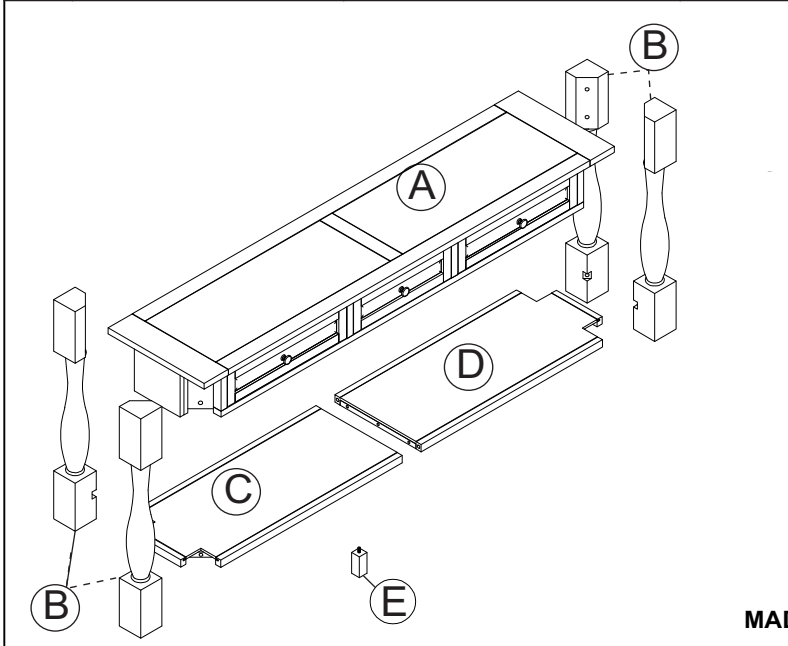

PART LISTS			
NO	DESCRIPTION	SKETCH	Q'TY
(A)	Table Frame		1 PC
(B)	Legs		4 PCS
(C)	Left Shelf		1 PC
(D)	Right Shelf		1 PC
(E)	Support Leg		1 PC

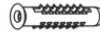
HARDWARE LIST			
NO	DESCRIPTION	SKETCH	Q'TY
(1)	Bolt 5/16" x 50mm		12 PCS
(2)	Spring Washer 5/16"		12 PCS
(3)	Washer 5/16"		12 PCS
(4)	Allen Key L=110		1 PC
(5)	Wooden Dowel \varnothing 10 x 30		2 PCS
(6)	Bolt 1/4" x 50mm		3 PCS
(7)	Spring Washer 1/4"		3 PCS
(8)	Flat Washer 1/4"		3 PCS

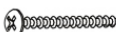

(9)	Anti Tip Kit		2 sets
(9.1)	Plastic Anchor		2 PCS
(9.2)	Metal Bracket		4 PCS
(9.3)	Long screw M4 x 40		2 PCS
(9.4)	Short screw M4 x 15		2 PCS
(9.5)	Steel wire		2 PCS

STEP 1

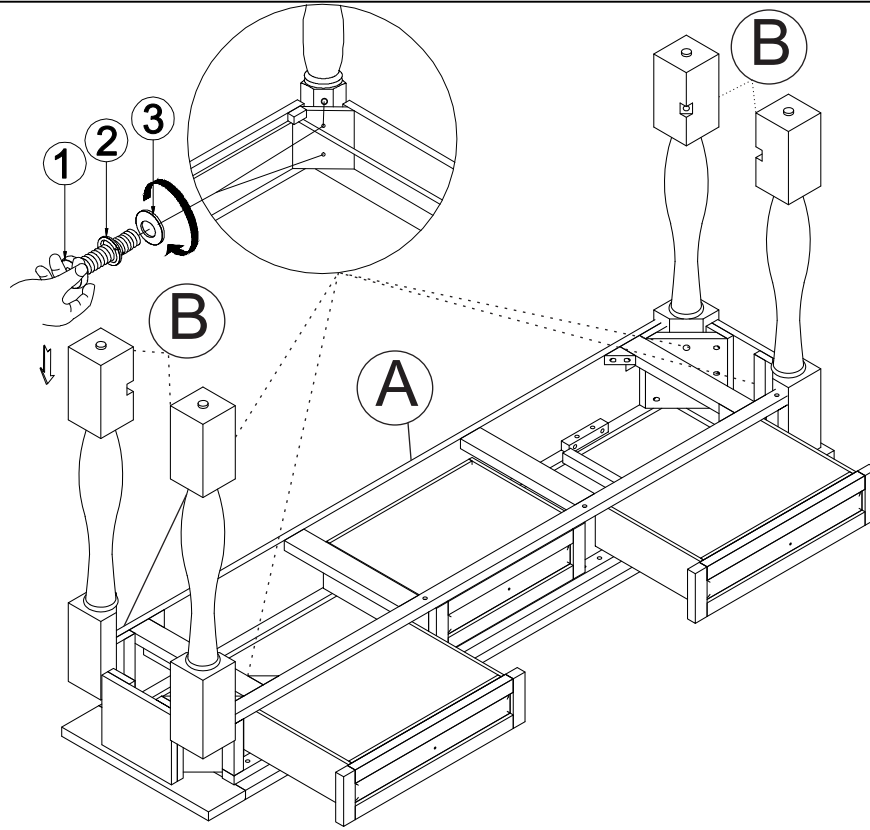

Do **NOT** overtighten hardware.
Tighten only 50% for now.



1 x 8 2 x 8 3 x 8

STEP 2

You must tighten 100% all Bolt this step

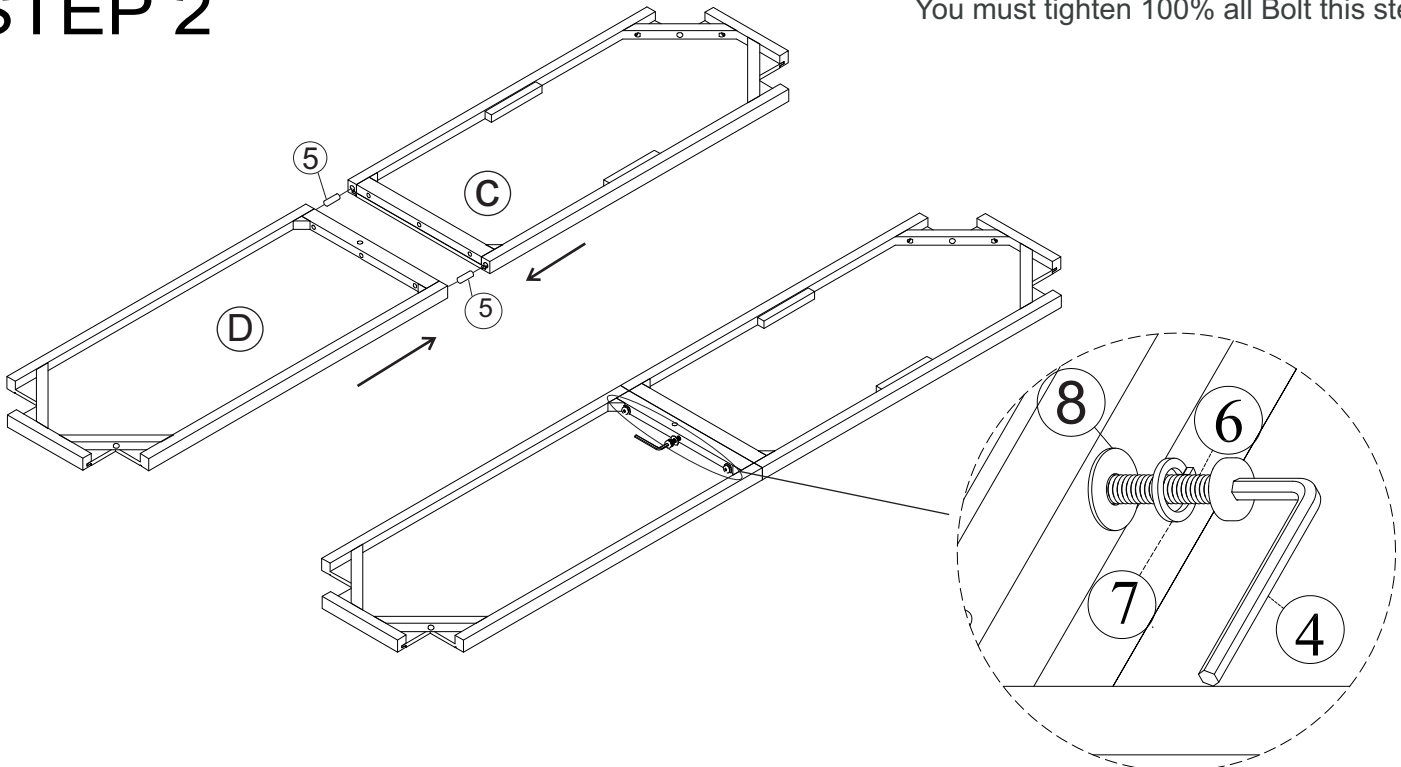

4 x 1 5 x 2 6 x 3 7 x 3 8 x 3

STEP 3

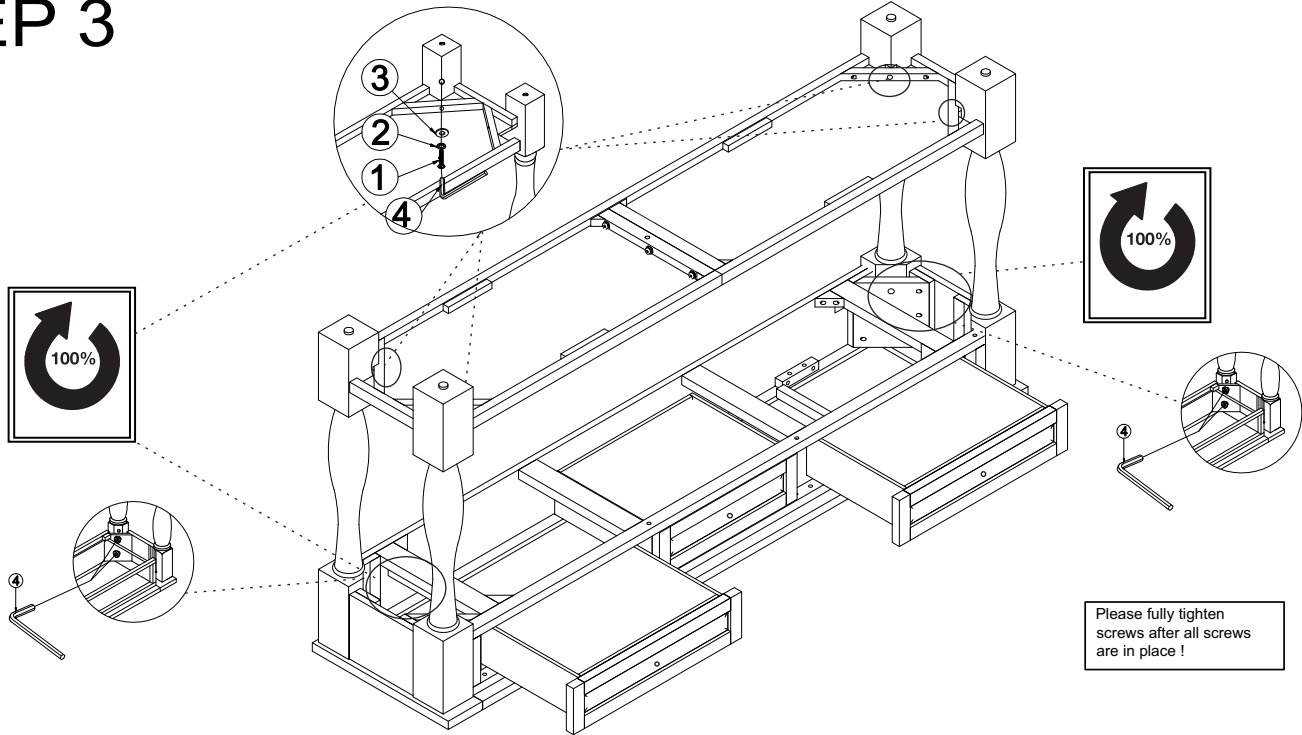

You can tighten 100% all Bolt this step

- 1 x4
- 2 x4
- 3 x4
- 4 x1

STEP 4

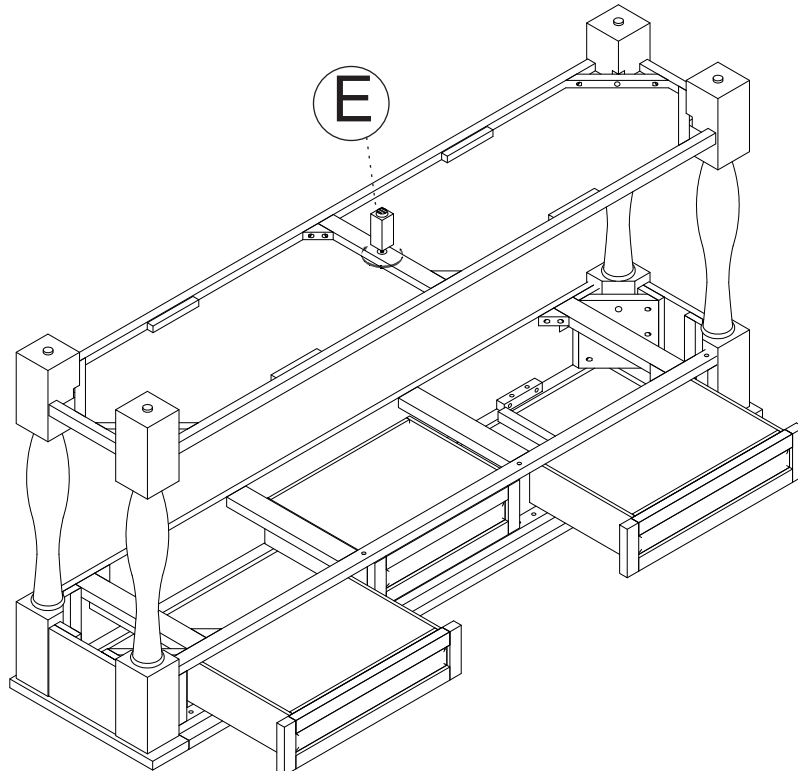



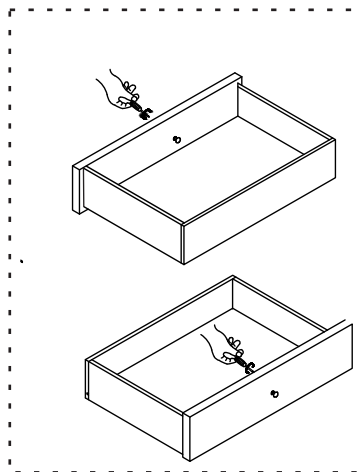
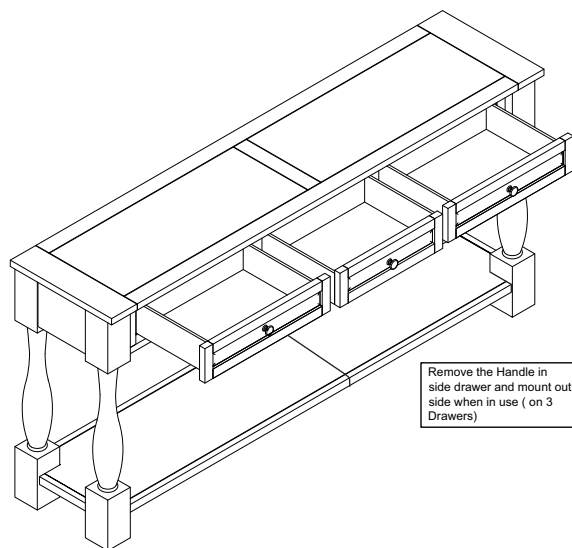

STEP 5

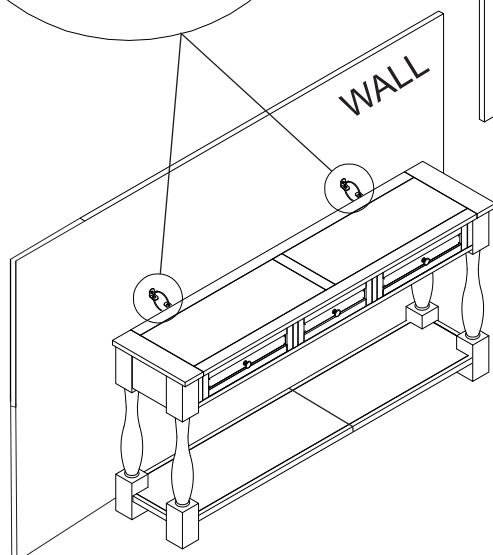
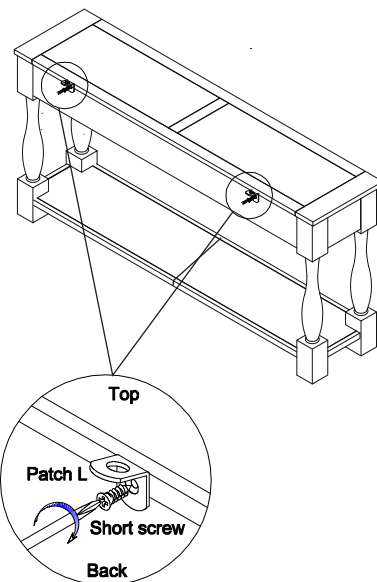
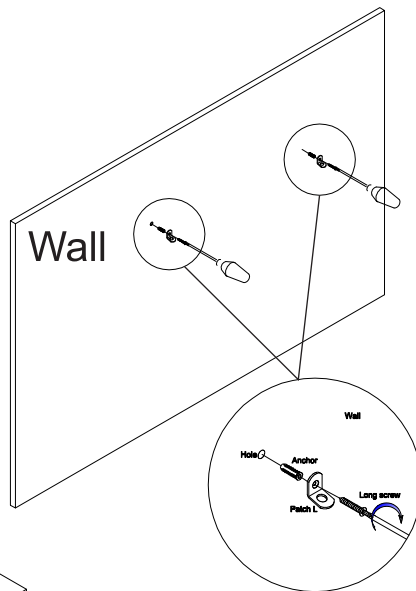
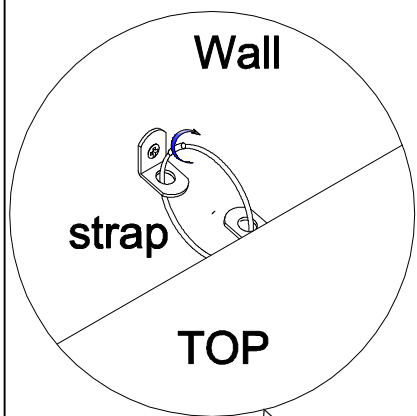

STEP 6



9. ANTI-PARKING KIT 2 SETS

				
2 pcs	4 pcs	M4 x 40 2 pcs	M4 x 15 2 pcs	2 pcs