



10X16 E-Z Frame Standard Structure Assembly Instructions

This kit includes:

- (12) 90 Degree Brackets
- (27) 120 Degree Brackets
- (34) I or 30 Degree Brackets
- (48) T Brackets

To complete your structure project you will need to purchase:

(74) 2X2 lumber - commonly known as a 2X2 – actual dimensions vary slightly from store to store. When purchasing your lumber it is a good idea to take one of your brackets along to verify that the lumber you are purchasing will fit your bracket correctly. You do not want the lumber to fit too loosely or too snugly. 2X2 lumber can come in pine, cedar, redwood or treated lumber. Treated lumber, redwood or cedar is best if planning to place your structure directly on the ground. Typically when buying 2X2 lumber, it is best to buy it in a bundle that is still strapped instead of loose lumber and let it sit for a couple of days to finish drying out before you cut the straps because pine lumber tends to twist if it has not finished drying yet. If buying unbundled boards just be sure to glance down the end of each board to make sure it is straight and does not have any bows in it before buying it.

(500) 1 ¼” wood screws

(6) Hinges (Be sure to buy a size hinge that will support the weight of your door)

(2) Door Latch

- Materials needed to cover your structure depending on use. This can be plastic, tarps, glass. Chicken wire, siding or metal. Or use your imagination!

Tools needed to complete structure:

- Table saw or skill saw
- Screw Gun, Drill with Phillips bit or a Phillips screwdriver (please keep in mind there are a lot of screws needed to fasten brackets so an electric screw driver of some sort would make the project much easier)
- Level
- Measuring tape

Assembly Instructions:

Step 1: Please make sure to read all the assembly instructions before starting your project.

Step 2: Identify all your brackets so you know which bracket goes where. The diagram below shows which bracket is used for which area of your project.

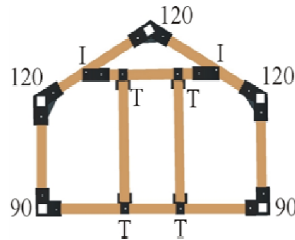

Please note: When assembling make sure brackets are facing the directions shown in this diagram.

Step 3: Measure and cut your lumber. Cut your lumber using a skill or table saw. All cuts are straight cuts – no angle cuts. If you are not a saw person – many local and main chain lumberyards will cut your lumber for you for free or a minimal charge. Cut your lumber as follows:

Note: As you measure and cut your lumber (done easily with a chop saw), please make sure you label each piece with the corresponding letter on your lumber cut list as this makes it easier to tell apart and assemble later. Wait to cut boards H, E and G until structure is complete to adjust door as needed.

Out of an 8' piece of lumber cut:

A = (18 ea) at 5' - 5 9/16"

B = (9 ea) at 6' - 3 5/8"

C = (18 ea) at 5' - 10"

D = (4 ea) at 4' - 10"

H = (4 ea) at 6' - 4"

K = (6 ea) at 6' - 8 1/2"

M = (10 ea) at 5' - 0"

N = (5 ea) at 6' - 0"

Out of remaining lumber cut:

E = (4 ea) at 2' - 2"

G = (6 ea) at 2' - 1 3/4"

L = (8 ea) at 1' - 6"

Assemble your structure:

Below is a diagram of an assembled structure. Your structure should look like this once assembled.



Note: When assembling your structure make sure you put a screw in each hole in each bracket to make sure your structure is rigid and solid when completed.

Step 4: Lay out your base first using your 90 degree brackets. Make sure (VERY IMPORTANT) that you face the brackets the way they are shown in the diagrams above. Failure to do this may make some measurements off later in assembly and the structure not go together properly. Layout your brackets and lumber for your base per the floor plan diagram below. Only put a single screw in piece of lumber on the door side of the building as you may have to adjust the studs to make sure the door fits correctly depending on the size hinges you will be using.

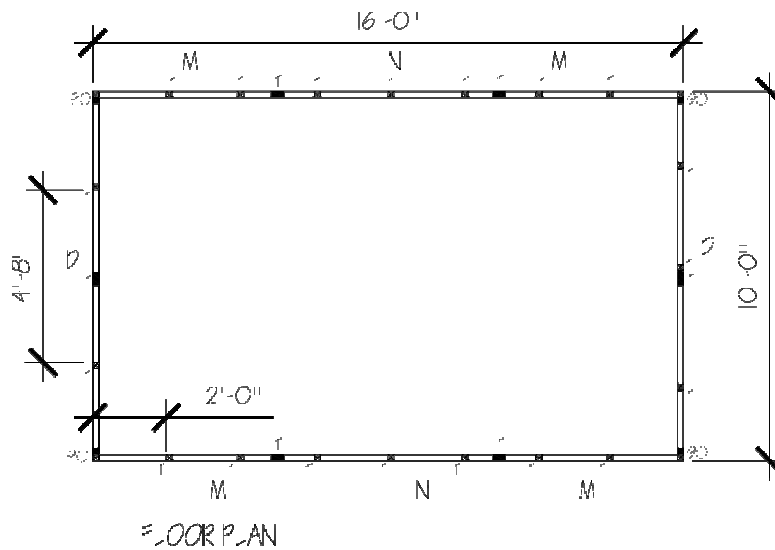

Step 5: Next assemble your roof trusses. It is typically easier to assemble them on the ground and then put them in to place on the stud walls. Make sure you use a level for the bottom of the truss (letter B) so they are level or measure down from the ridge bracket down each truss board. Failure to do this may push the truss out and cause it not to fit. Layout your roof as shown in the roof plan diagram below.

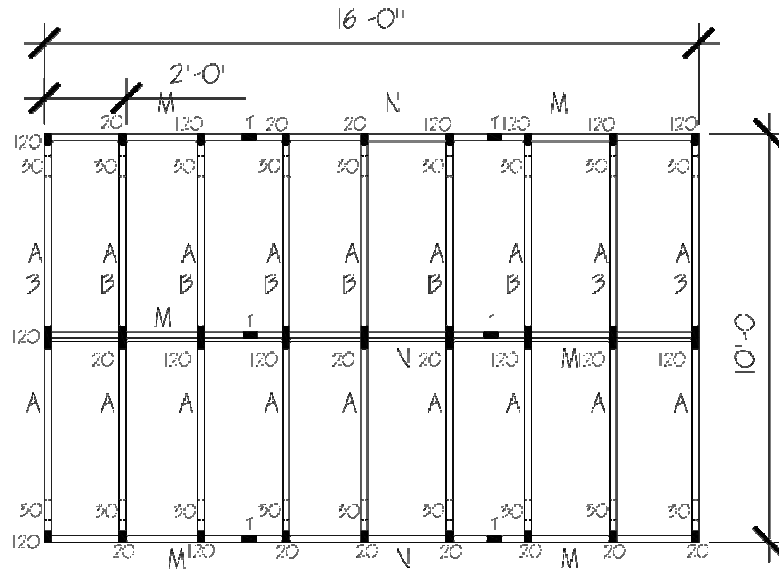

ROOF PLAN

Step 6: Next you can either add each of the stud wall pieces or assemble them all together on the ground and fit them in the base at once. Make sure you measure and evenly space all the brackets top and bottom. Next add your angled corner bracing to make your structure solid and rigid so you can add your trusses. Add your trusses to the top of each stud. When adding your trusses make sure the 120 degree ridge brackets are all facing the same direction so you will be able to add your ridge board. Add your ridge and top side wall boards by sliding them through the brackets and screwing them in to place. Make sure to measure again so all the boards are space evenly. Please see side elevation diagram below.

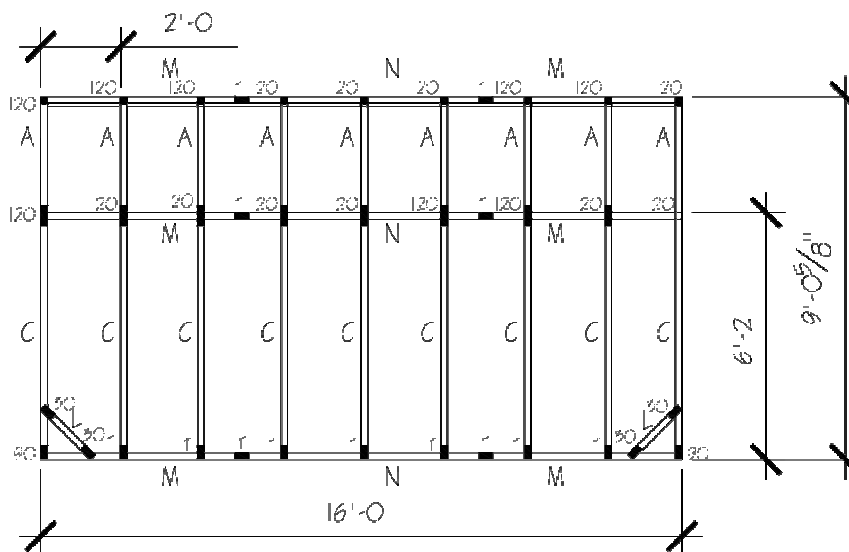

SIDE ELEVATION

Step 7: Add boards K to rear elevation as shown in rear elevation diagram below by sliding T brackets in to place first then adding studs, measuring do they are equally spaced and finally screwing them in to place.

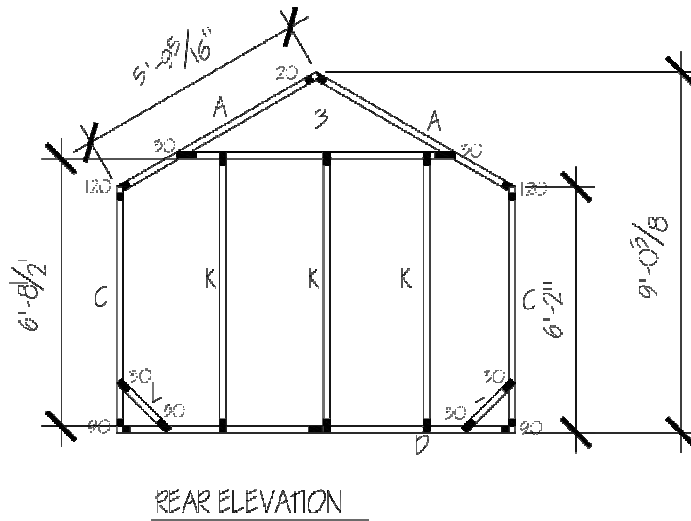

Step 8: Assemble the front of your structure. Do not add screws until you have everything adjusted how you would like them. First add your K boards by sliding in the T brackets and adding the studs. Then build your door assembly. Attach your door assembly using the hinges you purchased. Attach hinges to the K boards so the doors swing together like barn doors. There may be a small gap on either side of the door – this is designed so that if you purchase a non-flush hinge – the door will still open and close. If you do not wish to have a gap, you can cut your door assembly boards slightly larger for that or adjust the K boards to compensate. Finally measure and cut your E boards – these might be a slightly different length if you have adjusted the door assembly or K boards at all. Securely fasten everything with screws once you feel everything is adjusted and in place how you would like it. Please see the front elevation diagram below.

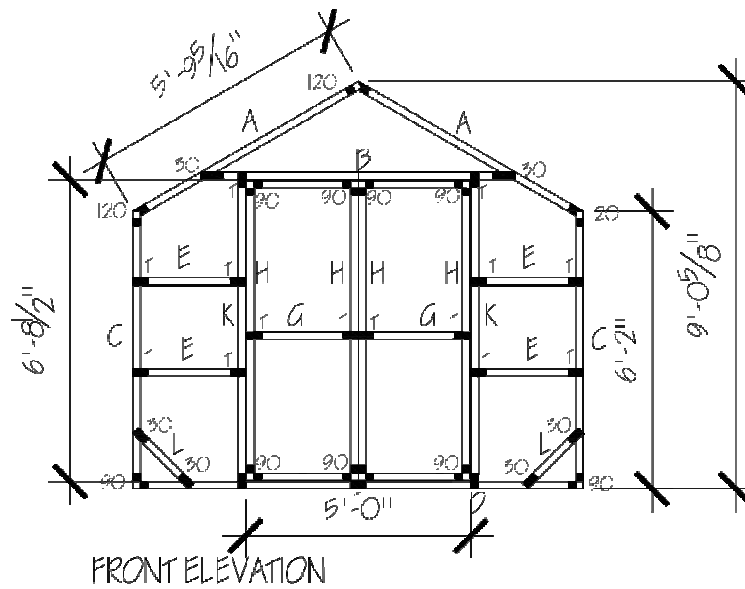

Step 9: Finally – measure your structure to determine the amount of materials you will need to purchase to cover your structure. Always make sure you allow for seams or waste material and purchase extra. To determine the

amount of material needed for the front and rear of the structure measure the base for your width and then measure from the base to the top of the ridge for your height.

Math hint: Measure the length and width of each section and then multiple those together to determine the sqft needed per section to cover that. Add each section of like materials together to determine the total amount of sqft you will need of that material.

Step 10: Stand back and admire your work!

Thanks for ordering E-Z Frames!

If you have any questions regarding your structure, please feel free to visit us at our website: www.ezframeup.com.



E-Z Frame Structures & Shelters LLC

E-Z Frame Structures & Shelters LLC and E-Z Framestructures.com are not responsible for any harm or damages to the structure or person as a result of misuse of the product or alteration of the design or design by someone other than E-Z Framestructures.com or E-Z Frame Structures & Shelters LLC. If you are unsure of the proper use of our brackets or structure kits, please contact us.