







ASSEMBLY INSTRUCTIONS

Read this instruction carefully. See hardware and Furniture part list for guidance.
 Be sure all parts are complete, before you assemble. Pace all wooden prevent from being scratched.
 Follow the figure to start assembling.

CAUTIONS: 1. Do not FULLY- TIGHTEN the nut or bolt until all nut and bolt is ready assembled.
 2. Do not OVER - TIGHTEN the nut or bolt avoid causing damages to the thread.
 3. Keep all hardware parts out of reach of children.

PART LIST		
ITEM	DESCRIPTION	QTY
A	LEG	4 PCS
B	ROUND FRAME	1 PC
C	GROSS SUPPORT (UP)	1 PC
D	GROSS SUPPORT (DOWN)	1 PC
E	CUSHION SEAT	1 PC

HARDWARE LIST		
ITEM	DESCRIPTION	QTY
1	WOOD DOWEL M10 x 30mm 	4 PCS
2	JCBC SCREW M6 x 35mm 	4 PCS
3	JCBC SCREW M6 x 40mm 	4 PCS
4	SPRING WASHER M6 	4 PCS
5	FLAT WASHER M6 x 13mm 	4 PCS
6	CSK SCREW M4 x 32mm 	4 PCS
7	ALLEN KEY M4 	1 PC

NOTE: THE LIST AND QUANTITY SHOWN ARE FOR 1 UNIT ASSEMBLY.

STEP 01

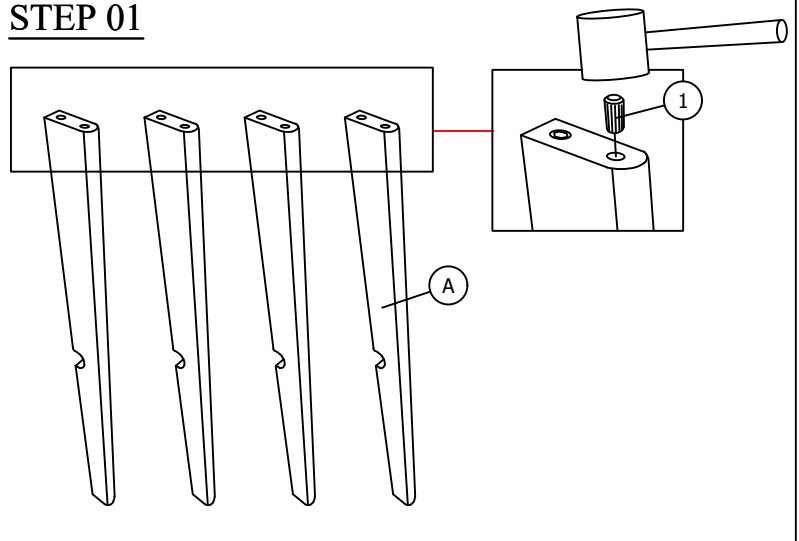

STEP 02

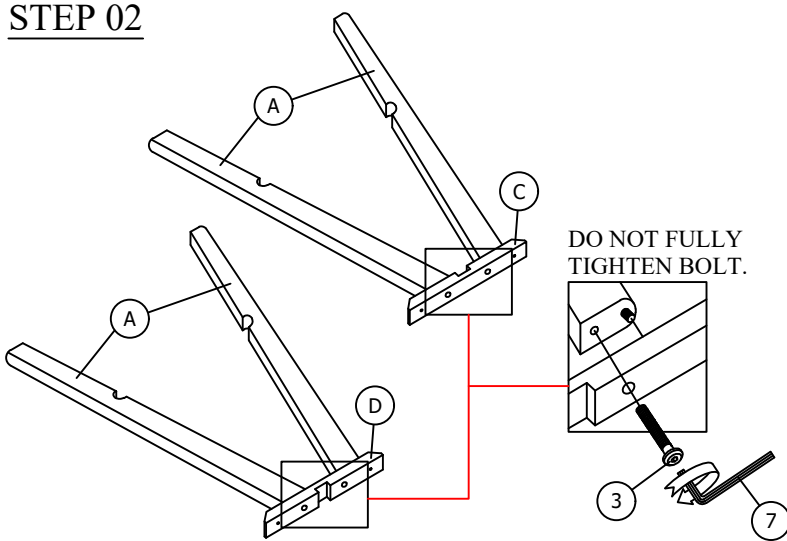

STEP 05

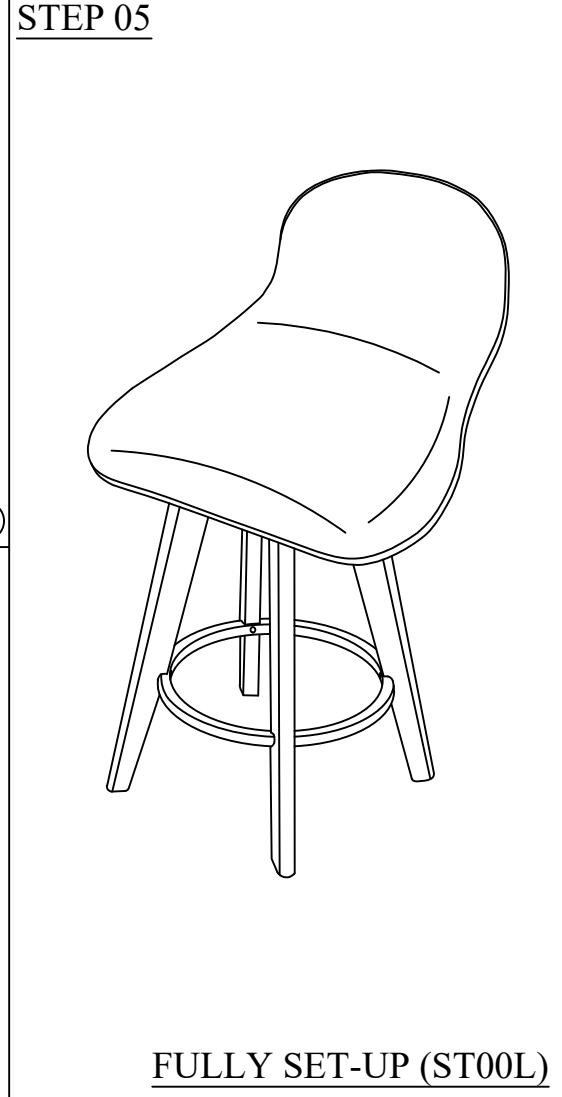

STEP 03

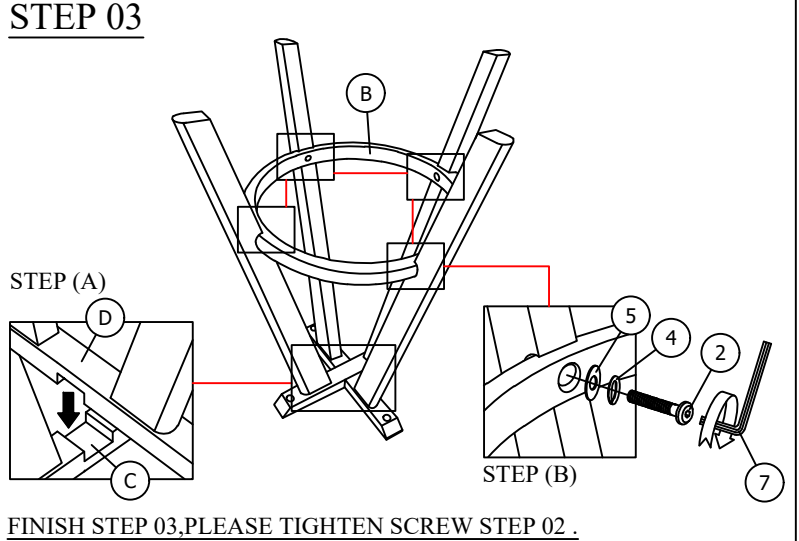

STEP 04

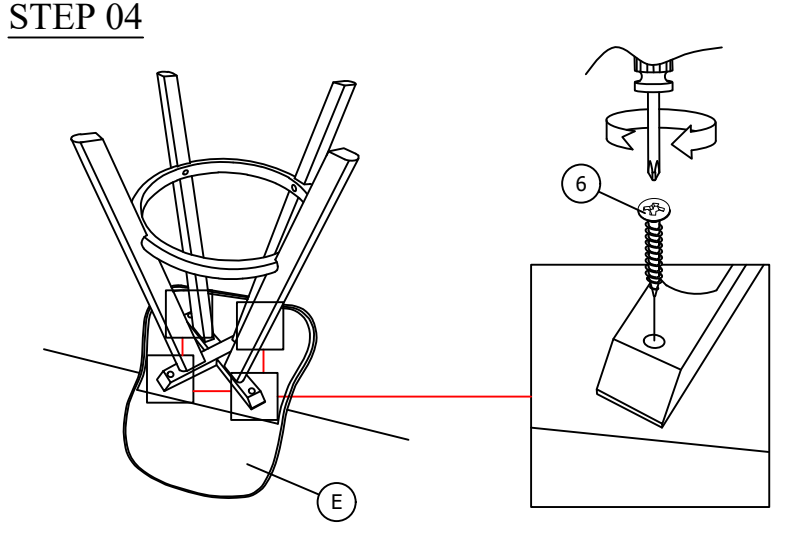

FULLY SET-UP (ST00L)