

NOTE: 50% TIGHTEN BEFORE FIXING ALL BOLTS

1 F  4pcs  
M 6X40

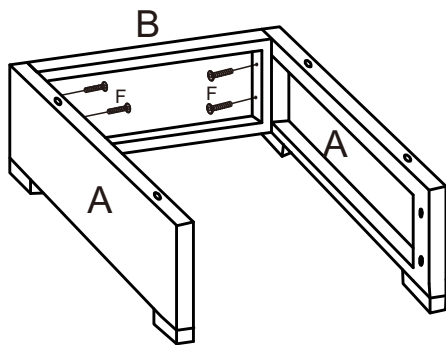

2 F  4pcs  
M 6X40

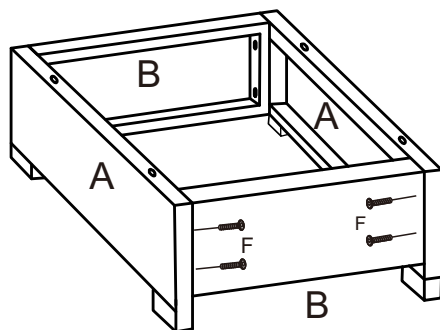

3 F  4pcs  
M 6X40

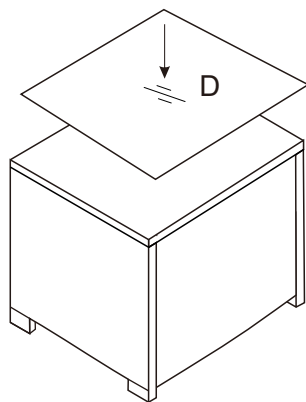
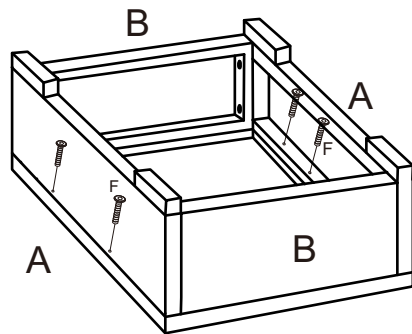

## INSTRUCTION MANUAL

# Coffee Table

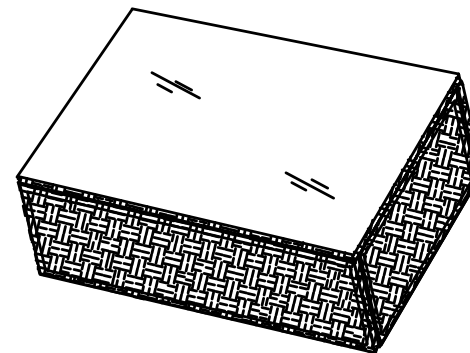

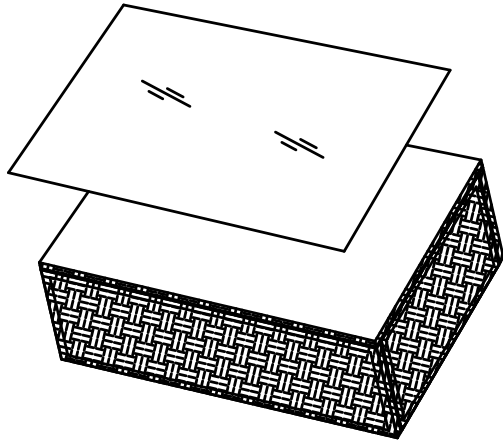

### Before You Begin...

This is a self assembly furniture set requiring at least 2 people to build. Do not tighten fastenings fully until assembly is complete and the product is on a flat and level surface. Please check all parts are present before starting assembly.

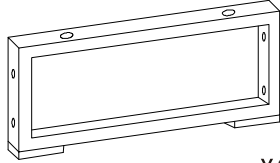
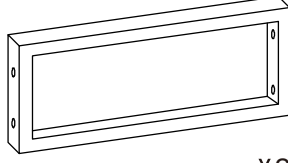
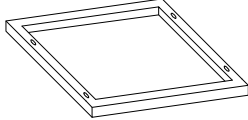
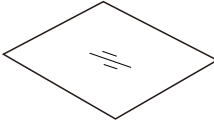

### Notice:

- 1.50% Tighten before fixing all screws, allen wrench is recommended instead of an electric drill,
- 2.Place the item on a flat ground to adjust and make sure it remains stable,
- 3.Tighten up all screws with tools gradually,
- 4.If the screws are not aligned with holes during assembly, please loosen all the other screws to 50% and continue the assembly process,
- 5.If the item is not stable, please loosen all the screw, adjust it on a flat ground and tighten up all screws again,
- 6.Note: If one or some screws are fully tightened during assembly, chances are the others will not be aligned with holes. In addition all the holes are designed to be relatively larger to provide more space for the adjustment of the screws.

A  X2	B  X2	C  X2
D  X1	E  X1	F  M 6X40 X12