

ASSEMBLY INSTRUCTIONS

**RECTANGULAR DINING
TABLE**

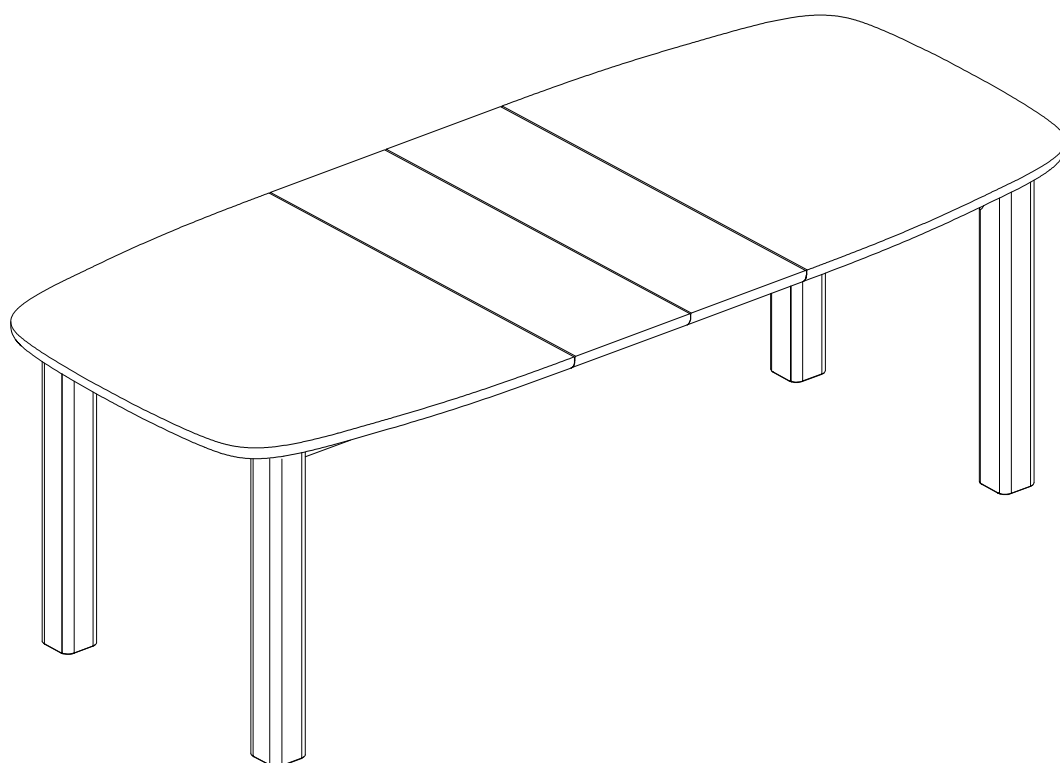

RECTANGULAR DINING TABLE

ASSEMBLY INSTRUCTIONS

Please kindly read these instructions carefully and keep for future reference. Refer to parts inventory for guidance, and ensure you have all pieces before starting.

When assembling, place all parts on a soft, clean, and flat surface such as a carpet to prevent scratches.

If you're having difficulty, our friendly Customer Care team is always here to help.

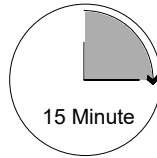

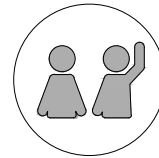

TIME



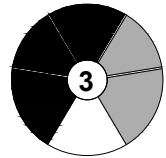

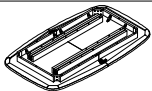
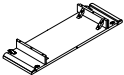

OF PEOPLE

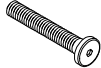

DIFFICULTY

CODE	PART LIST	Q'TY
①	TOP 	1 PC
②	LEAF TOP 	2 PCS
③	LEGS 	4 PCS

CODE	HARDWARE LIST	Q'TY
Ⓐ	BOLT M8x60 	8 PCS
Ⓑ	SPRING WASHER 8.5 	8 PCS
Ⓒ	FLAT WASHER 8.5 	8 PCS
Ⓓ	ALLEN KEY K4 	1 PC
SCREW DRIVER (NOT INCLUDED) 		

Note: Make sure you have all the parts and hardware with quantity listed above before assembling the product. A screwdriver is also required (not included)

STEP 1

NOTE: FIRST, TIGHTEN ALL BOLTS TO 80%
THEN TIGHTEN ALL BOLTS TO 100%
- PLEASE FOLLOW THE STEPS ABOVE TO AVOID
THE ASSEMBLY DIFFICULTY

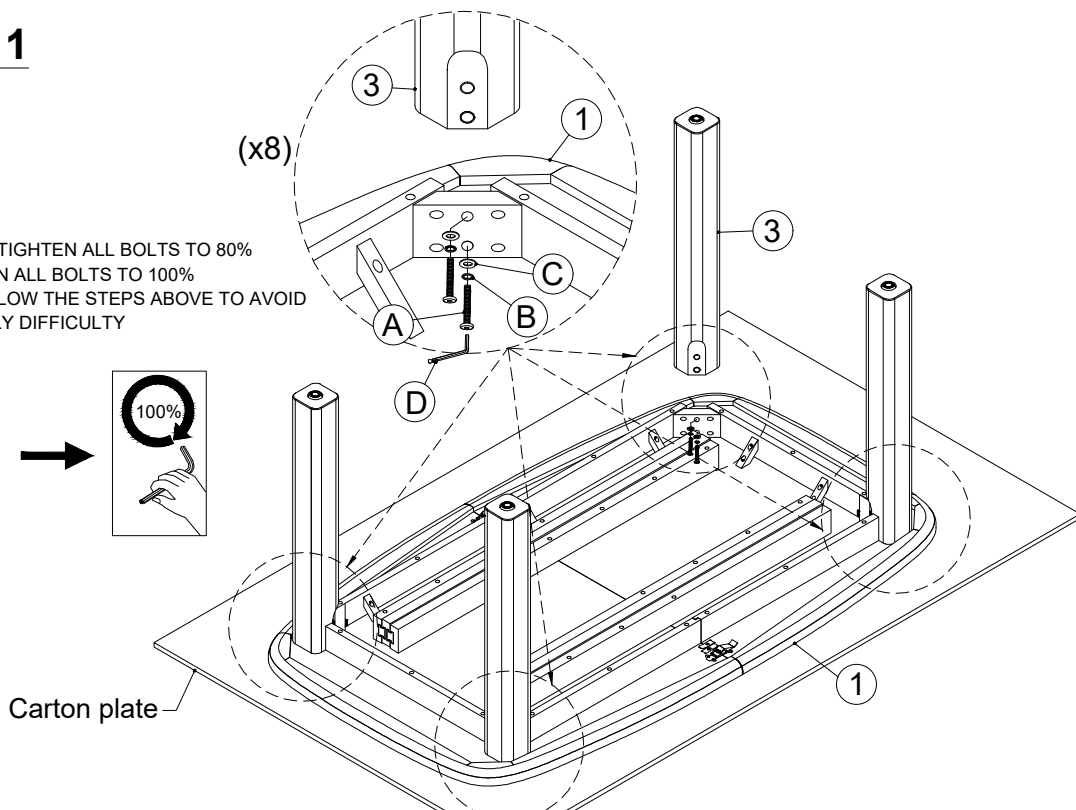
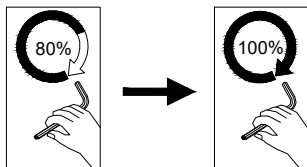

RECTANGULAR DINING TABLE

STEP 2

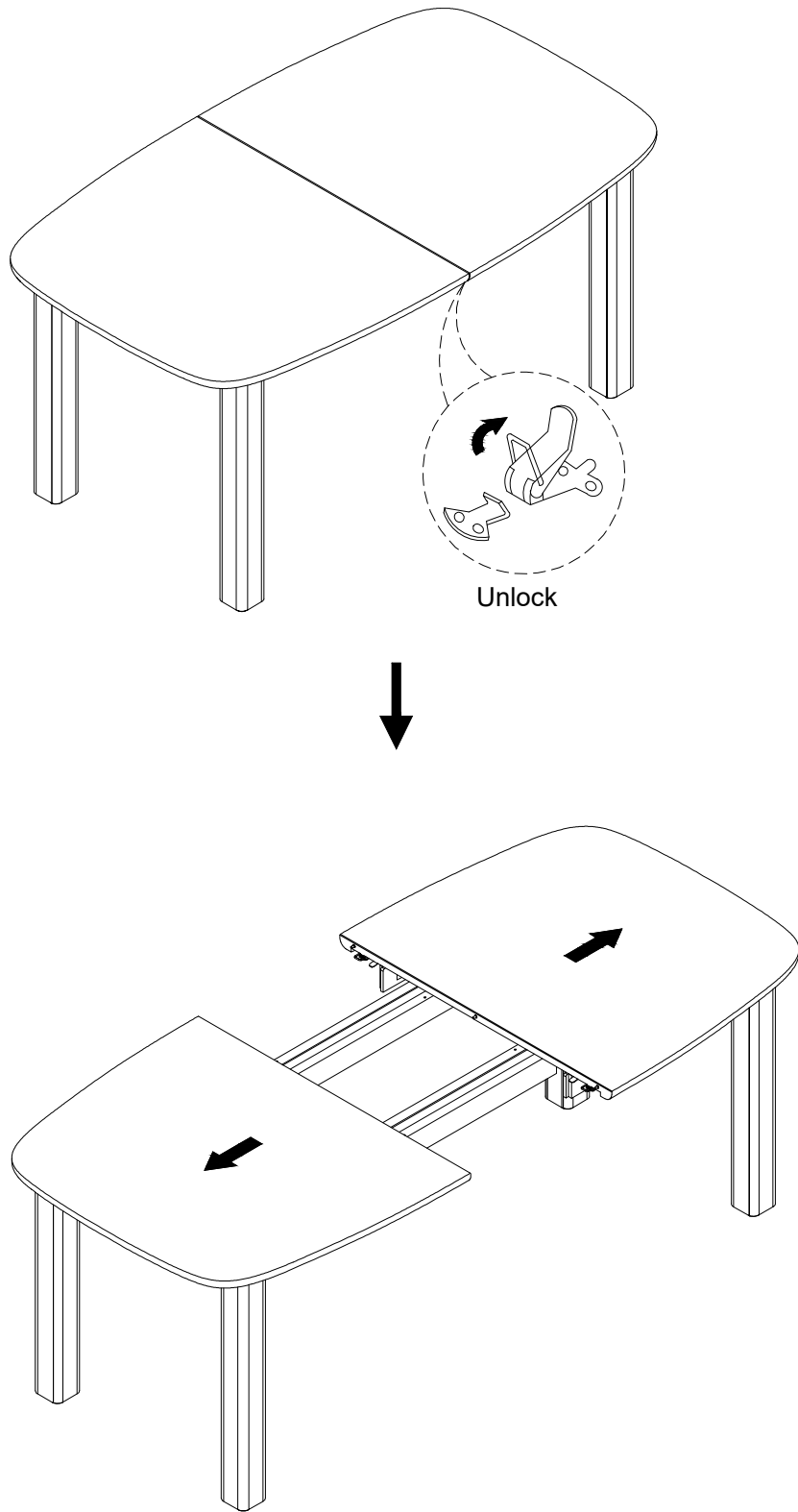

RECTANGULAR DINING TABLE

STEP 3

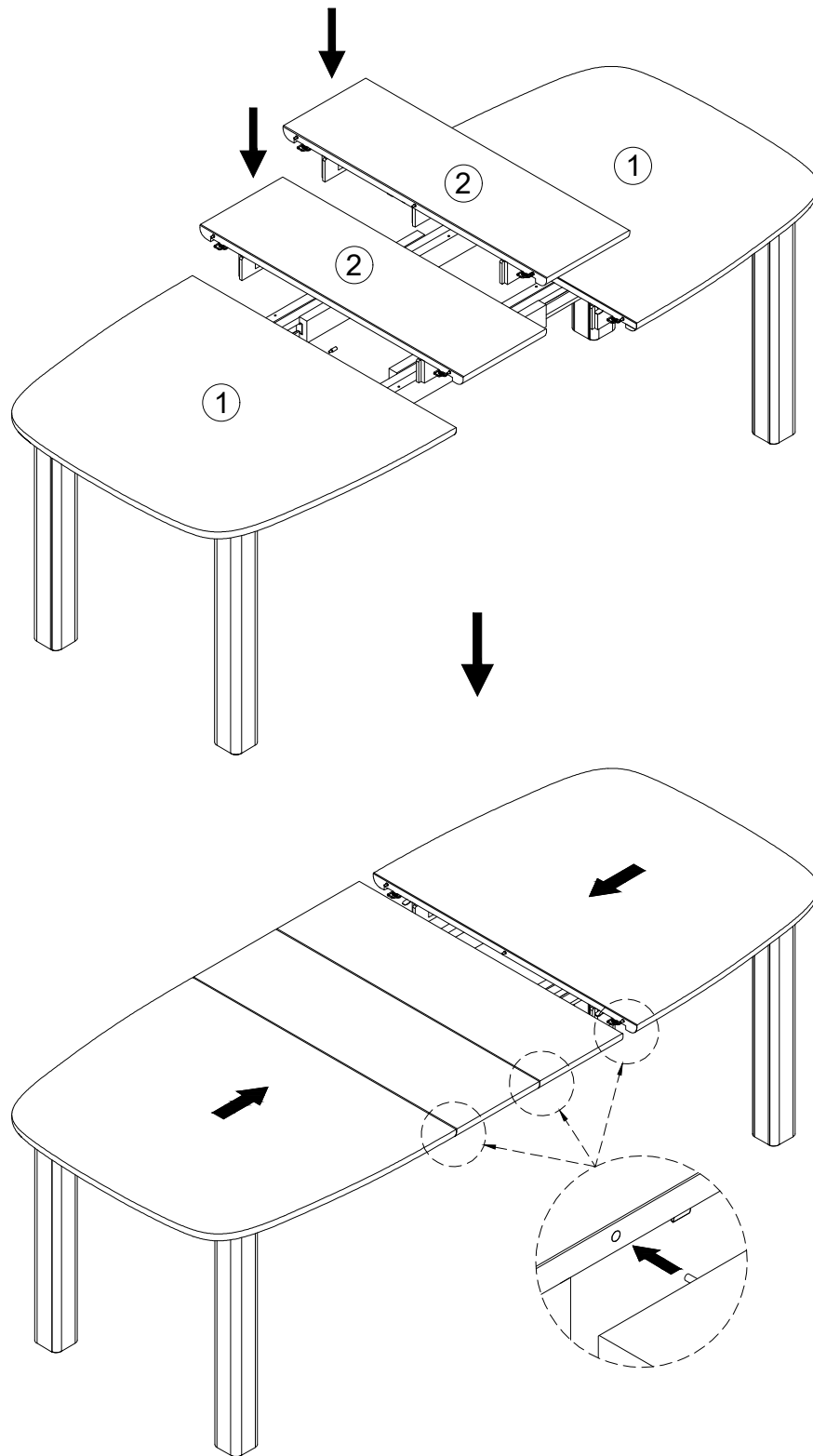

RECTANGULAR DINING TABLE

STEP 4

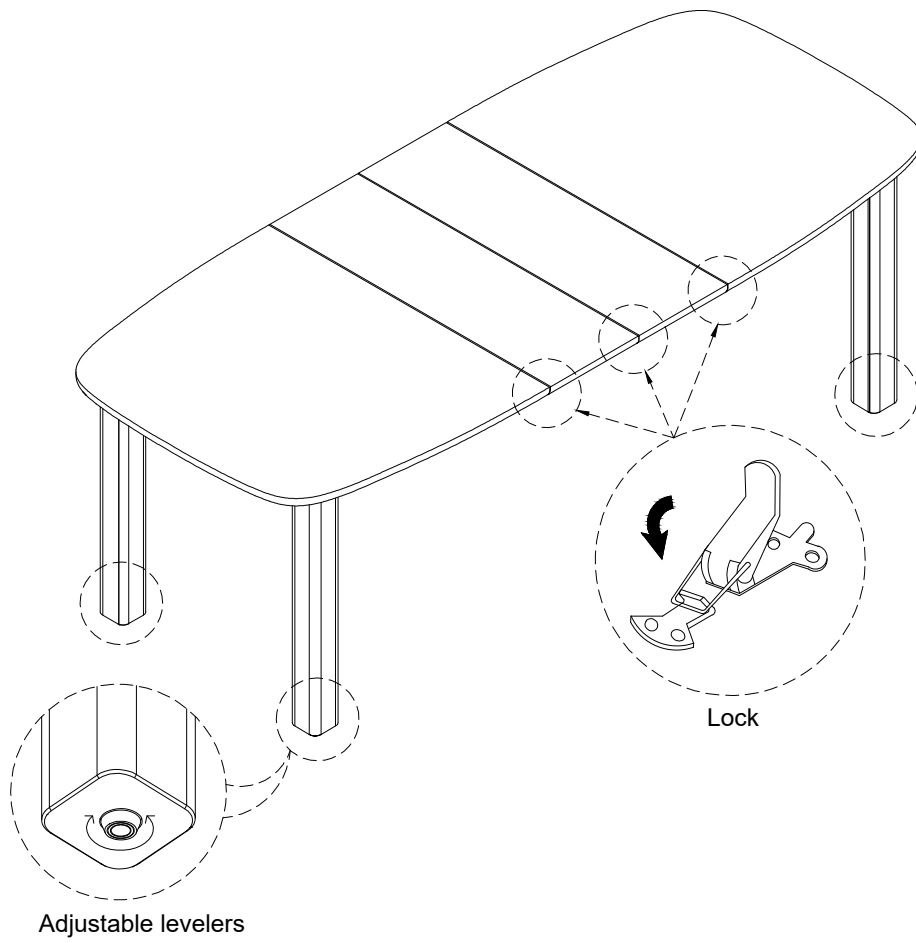

STEP 5 **FINISHED**

