

Assembly Instructions

Preparation checklist







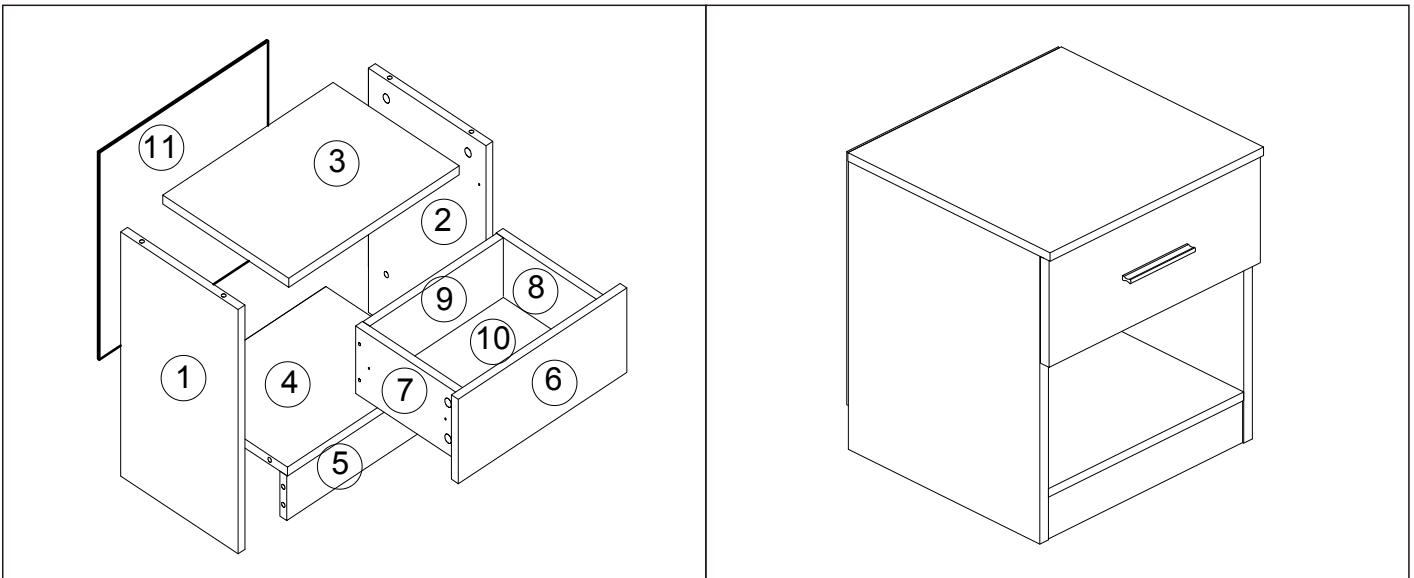

- Carefully check that you have all the components prior to assembly.
- Unpack and assemble it on a clean, flat, protective surface in the room it will be used.
- We recommend that the packaging is used to protect the surfaces during assembly.
- It may be necessary to tighten any fittings from time to time depending on use, this is normal with flat pack furniture.
- Save all packing material until assembly is complete to avoid accidentally discarding smaller parts or hardware.
- Please clean the product using either a damp (not wet) cloth and a mild domestic soap solution or by using an appropriate polish.
- Do not use abrasive materials when cleaning

Part list

NOTE: Lay all parts on a soft protected surface

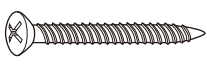

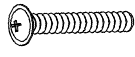
Fitting list

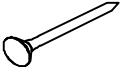
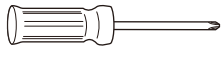
 Cam Bolt - 14 pcs(A)	 Cam Lock - 14 pcs(B)	 Dowel - 2 pcs(C)	 15mm Screw- 8 pcs(D)	 35mm Screw- 4 pcs(E)	 Slide - 1 pcs(F)
 Handle- 1 pcs(G)	 Pan-head Screw - 2 pcs(H)	 Leg cover - 4 pcs(I)	 Nail - 17 pcs(J)	 Screwdriver-1pcs	

Additional tools required

Step 1

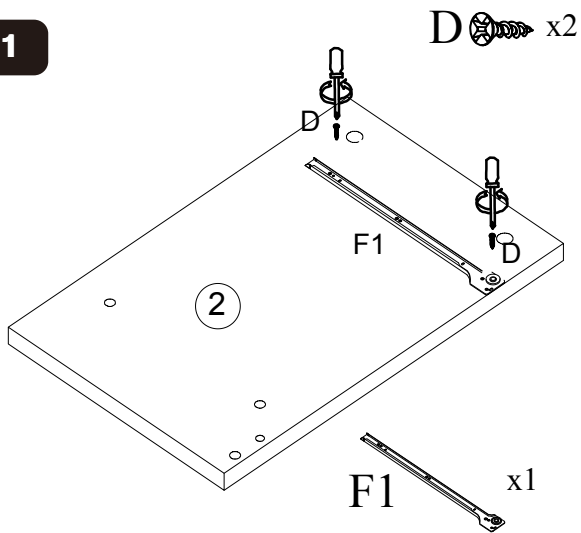

Step 2

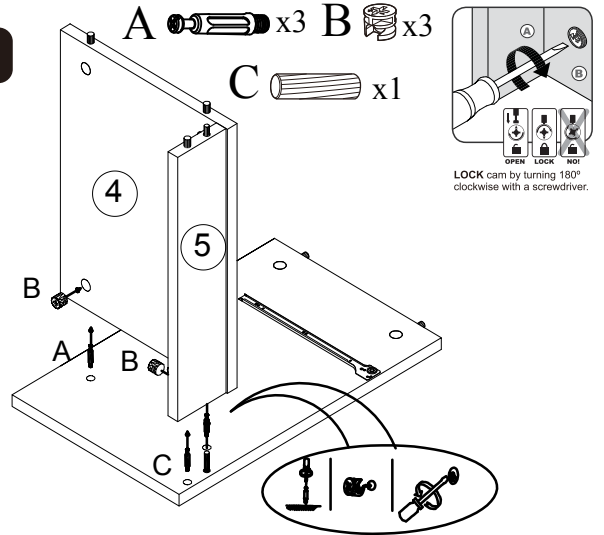

Step 3

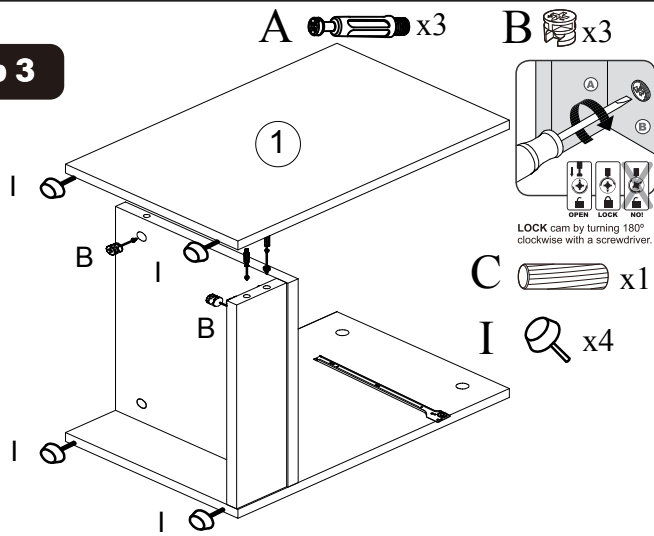

Step 4

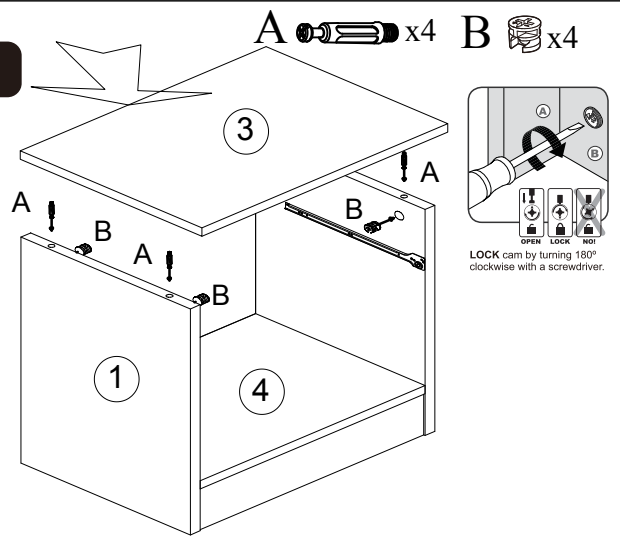

Step 5

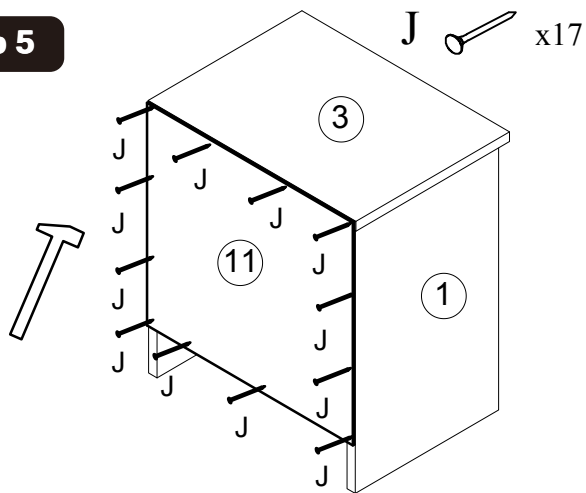

Step 6

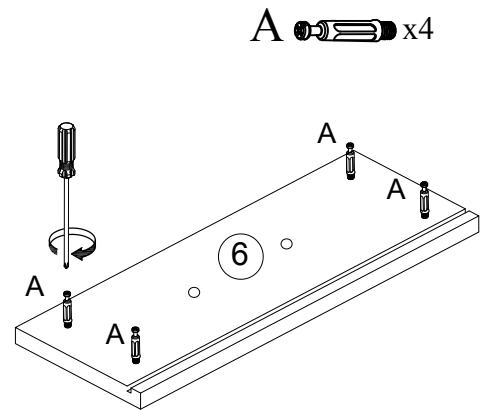

Step 7

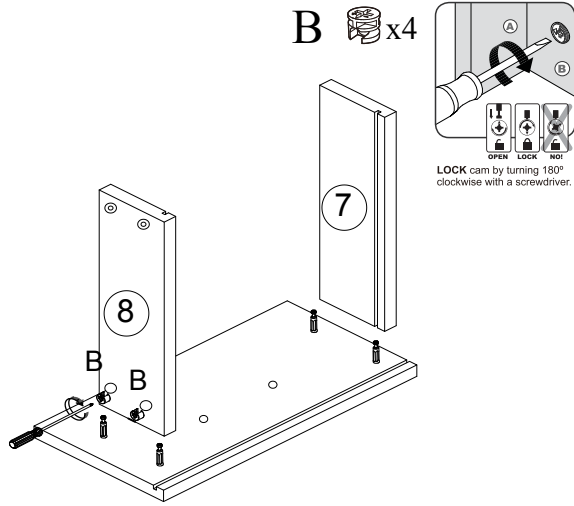

Step 8

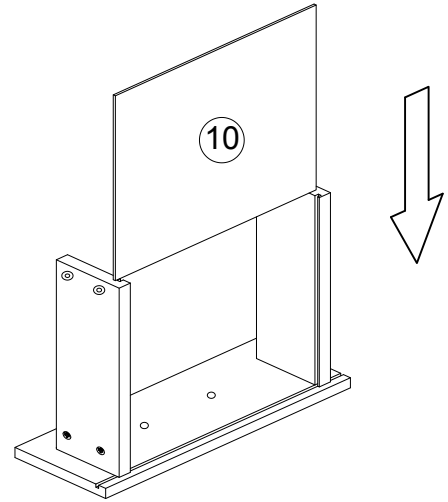

Step 9

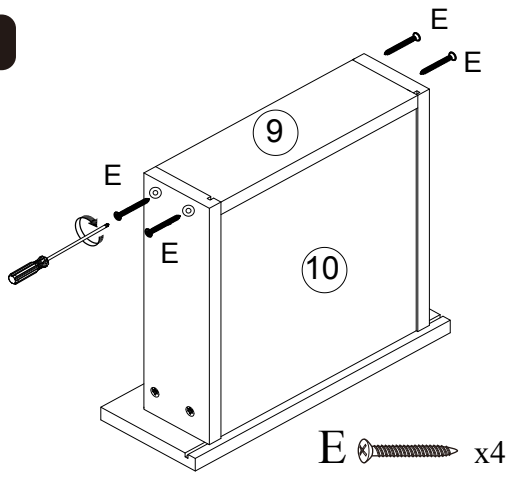

Step 10

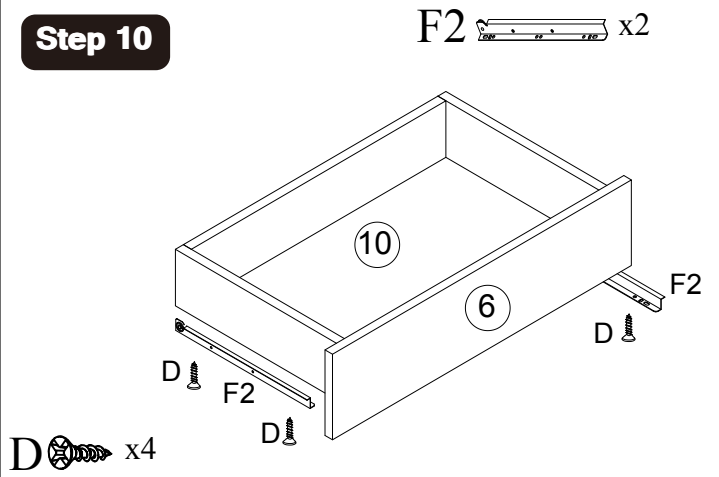

Step 11

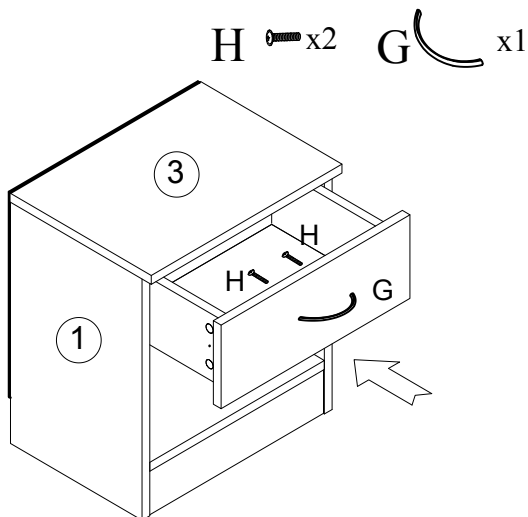

Step 12

