

PRODUCT FEATURES

- Influenced by the Bauhaus movement, generously sized geometric metal stamped plates house integrated LEDs providing a generous amount of indirect illumination to any space
- Modern finishes available
- Complete the look with Line-Voltage Pendants and Bath Bar
- Includes two sets of (2) 6" and (4) 12" rigid stems. Due to weight, J-Box must hold a minimum of 150 lbs
- This item is made of natural brass. It is a living finish that will patina and warm with age which adds richness. If it gets an uneven patina or spots, a brass cleaner can restore the finish
- Protected by a 5-year warranty. Please visit the "About Us" Page on techlighting.com for more for warranty details

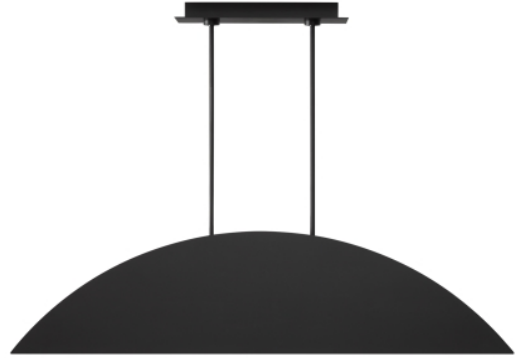

LAMPING

Includes 58.3 watts, 1211 total delivered lumens, 3000K LED modules. Dimmable with most LED compatible ELV and TRIAC dimmers. Includes (8) 12" and (4) 6" rigid stems in coordinating finish. Can be installed on a sloped ceiling up to 20°.

Nightshade Black



Nightshade Black

Nightshade Black
3/4

Natural Brass

Natural Brass 3/4

ORDERING INFORMATION

700LSBAU50 FINISH

- NB NATURAL BRASS
- B NIGHTSHADE BLACK

LAMP

-LED930 INTEGRATED LED 90 CRI 3000K 120V

700LSBAU50 _____

JOB NAME _____

NOTES _____



BAU 50 LINEAR SUSPENSION



SPECIFICATIONS

| | |
|-------------------------------|-------------|
| HARDWARE MATERIAL | Metal |
| SHADE MATERIAL | Aluminum |
| NET WEIGHT | 41 lbs |
| HEIGHT | 12in |
| WIDTH | 3.2in |
| LENGTH | 49.2in |
| UP LIGHT / DOWN LIGHT / BOTH? | |
| WET LISTED | |
| DAMP LISTED | Yes |
| DRY LISTED | |
| MIN. HANGING HEIGHT | 19.7in |
| MAX HANGING HEIGHT | 73.7in |
| TOTAL CORD LENGTH | |
| TOTAL STEM LENGTH | Up to 120in |
| STEM QTY | 12 |
| SLOPED CEILING ADAPTABLE? | Yes 20° Max |
| GENERAL LISTING | ETL Listed |
| INCLUDES | |

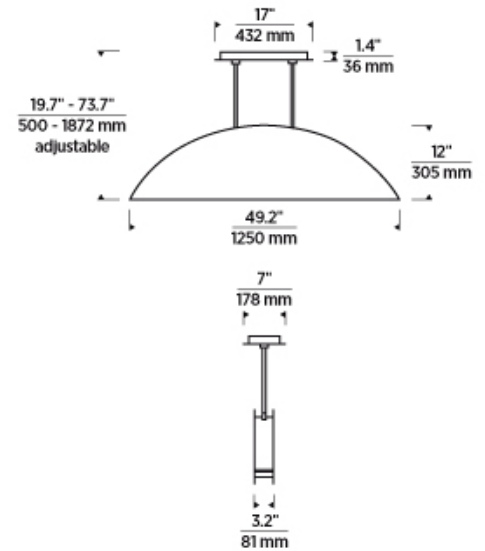

LAMPING SPECIFICATIONS

| | LED LAMP | INTEGRATED LED | NON LED | NO LAMP |
|-----------------------|----------|----------------|---------|---------|
| DELIVERED LUMENS | | 1211 | | |
| WATTS | | 58.3 | | |
| MAX WATTAGE PER BULB | | 58.3W | | |
| INPUT VOLTAGE | | 120VV | | |
| DIMMING TYPE* | | ELV, TRIAC | | |
| CCT | | 3000K | | |
| CRI | | 90 CRI | | |
| LED LIFETIME | | | | |
| L70 | | >50000 | | |
| AVERAGE BULB HOURS | | | | |
| FIELD SERVICEABLE LED | | | | |
| LAMP BASE | | Integrated LED | | |
| LAMP SHAPE | | Integrated LED | | |
| LAMP INCLUDED? | | True | | |
| WARRANTY** | | 5 Years | | |

*Dimming information available at www.techlighting.com/Downloads#dimming

** Visit techlighting.com for specific warranty limitations and details.

T20 / T24 / JA8 INFORMATION

| | Integrated LED | Replacement LED Lamp | No Lamp * |
|---|----------------|----------------------|-----------|
| This product can be used to comply with California Building Energy Efficiency Standards 2016 Title 24 Part 6 / JA8. | No | | |
| This product can be used to comply with California Appliance Efficiency Standards 2016 Title 20 and may be shipped to and sold in California. | N/A | | |

* If a light fixture or component does not include a lamp or light source, it is the responsibility of the customer to select a lamp that meets the T24 and T20 requirements.

