

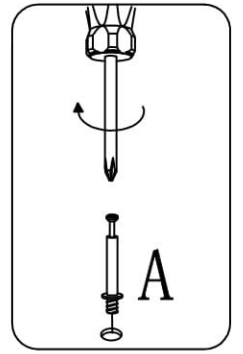

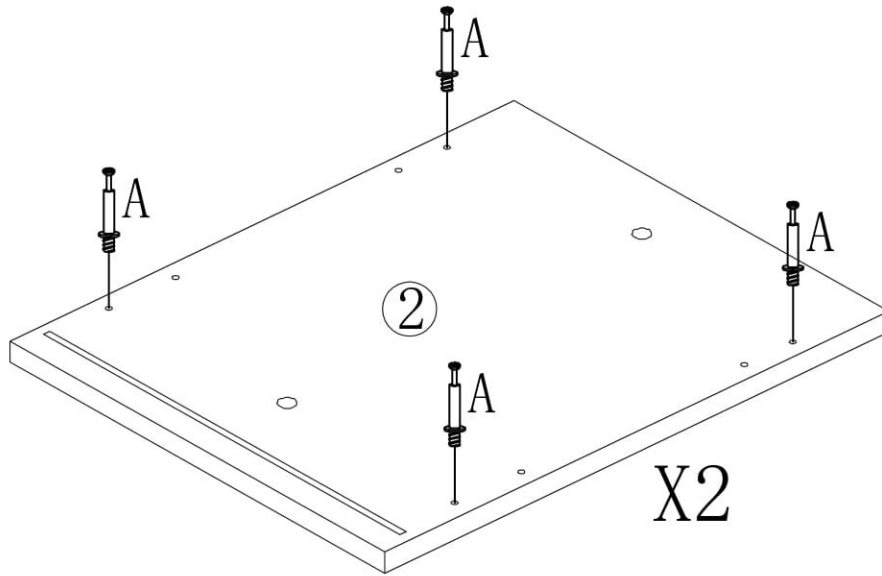

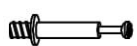

# STEP 1

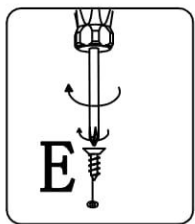
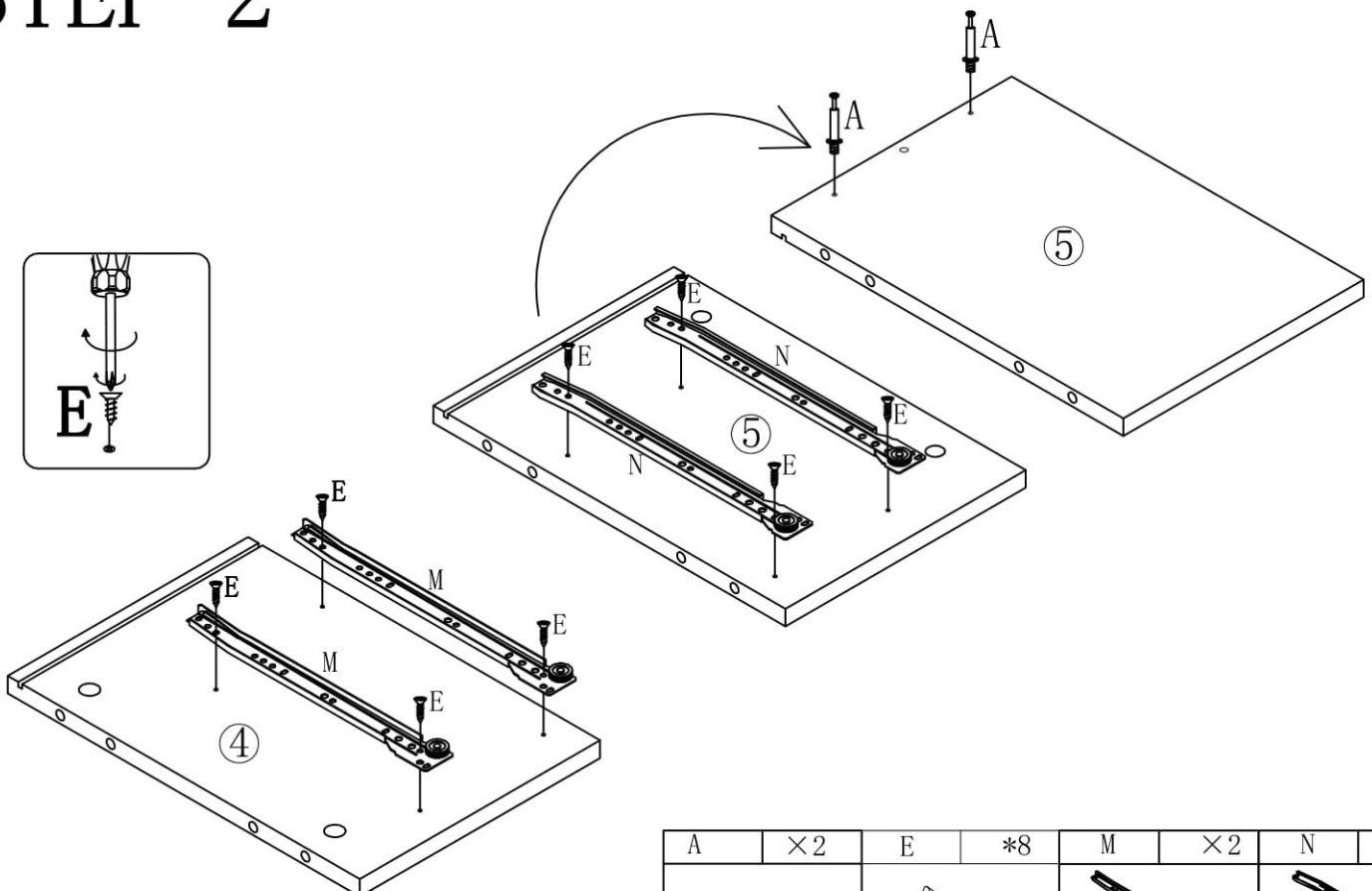

A	×8
	
∅6*35mm	

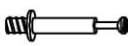

# STEP 2



A	×2	E	*8	M	×2	N	×2
							
∅6*35mm		3.5*12mm		L350mm		L350mm	

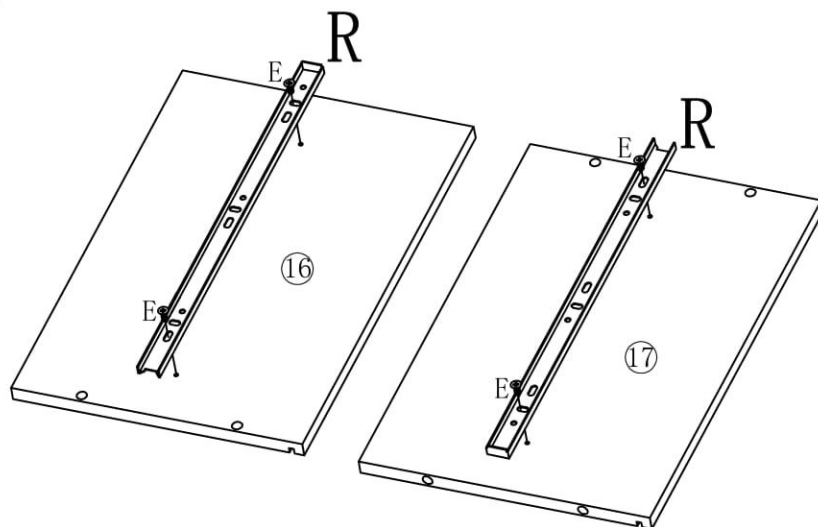
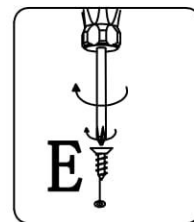
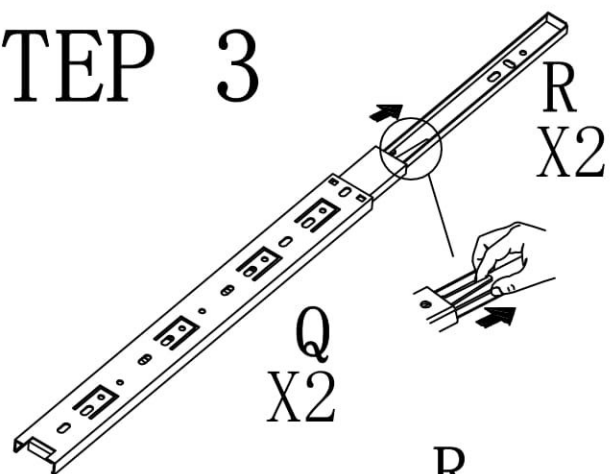

# STEP 3

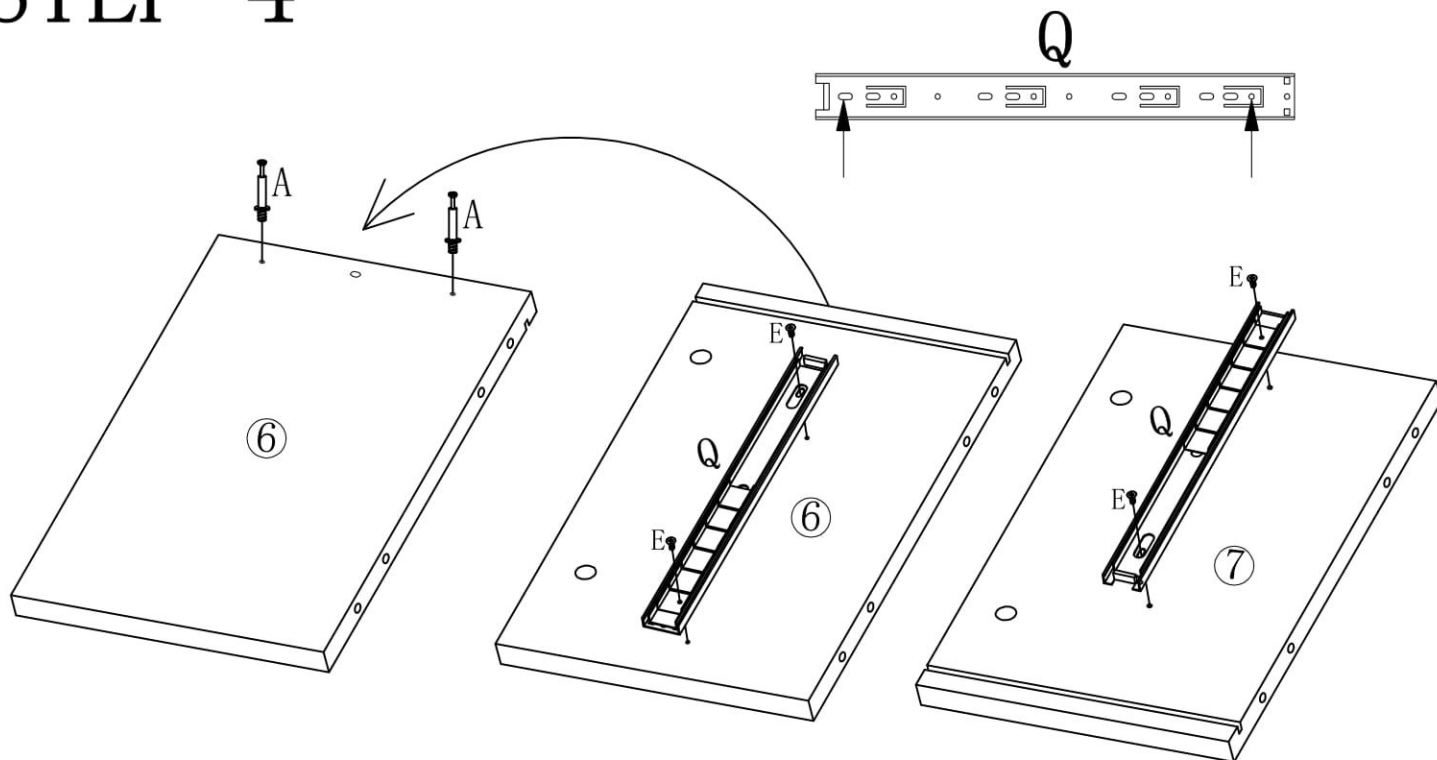

E	*4	R	×2
			
3.5*12mm		L350mm	

# STEP 4

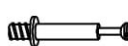

A	×2	E	*4	Q	×2
					
∅6*35mm		3.5*12mm		L350mm	

# STEP 5

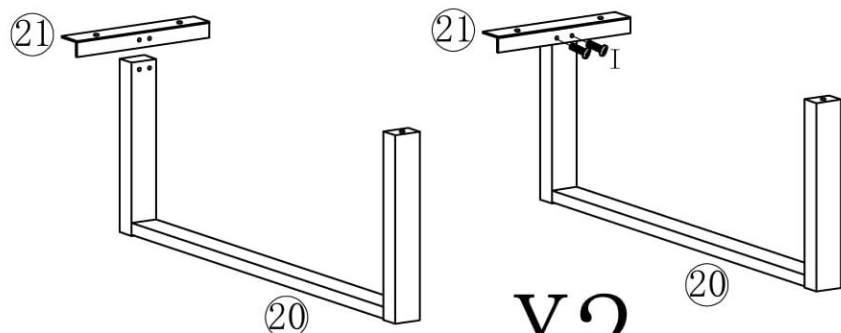
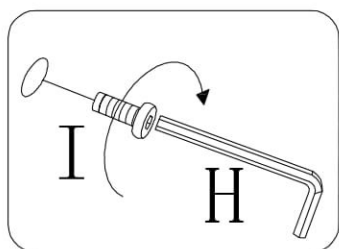

X2

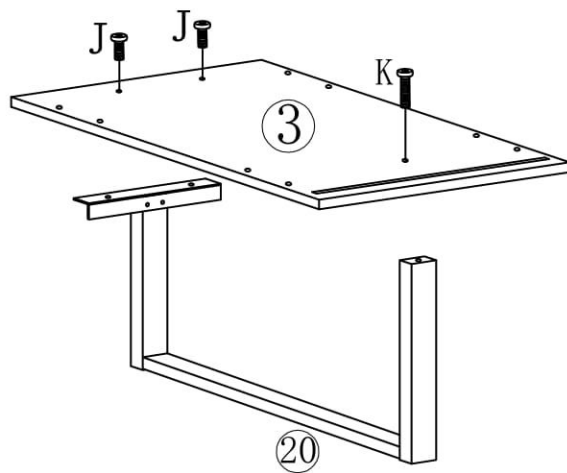

H	*1	I	*4	J	*4	K	*2
M4X55		M6*15mm		M6*20mm		M6*35mm	

# STEP 6

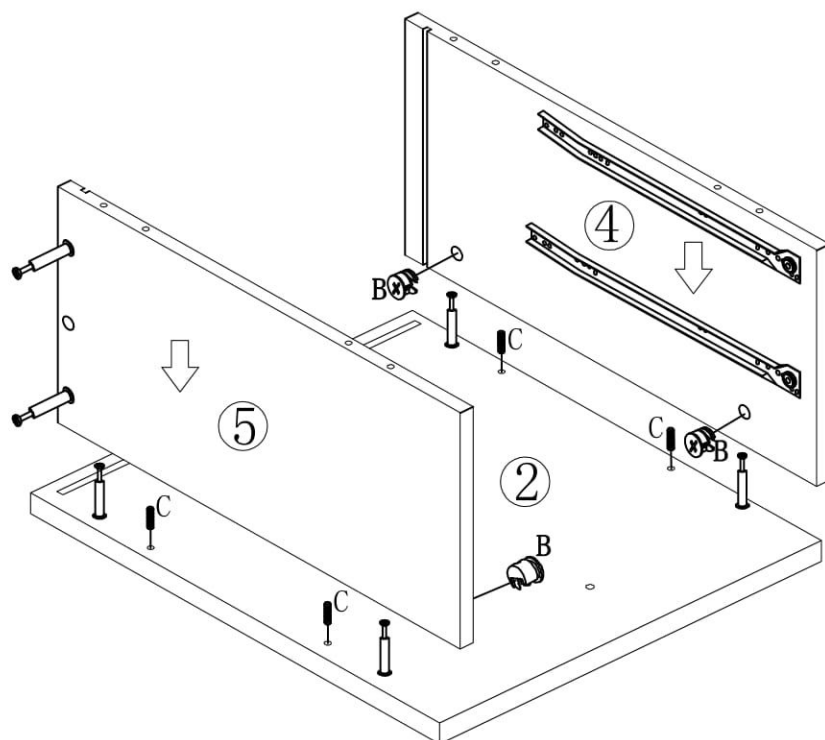

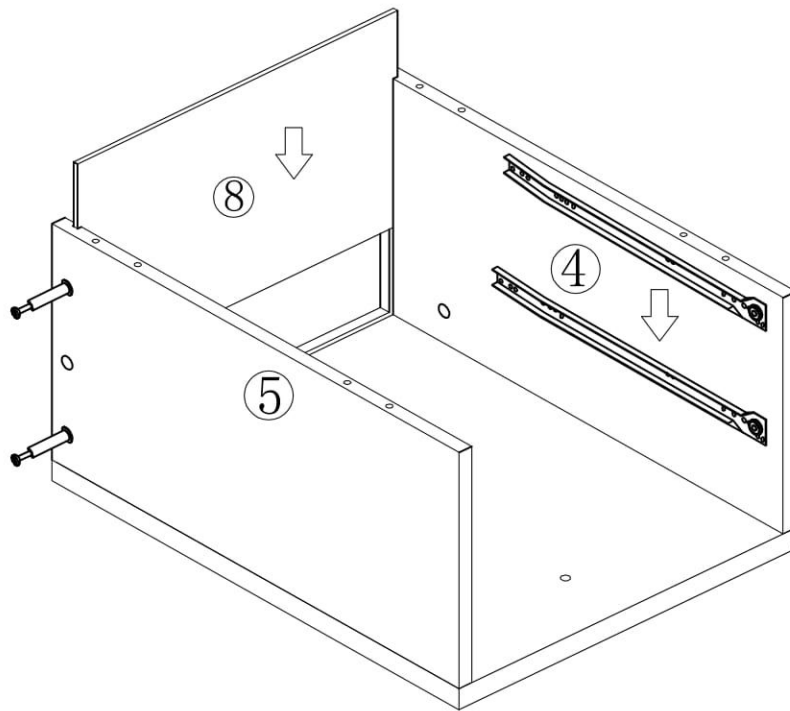

B	*4	C	*4
φ 15X19		φ 7 8X30	

# STEP 7



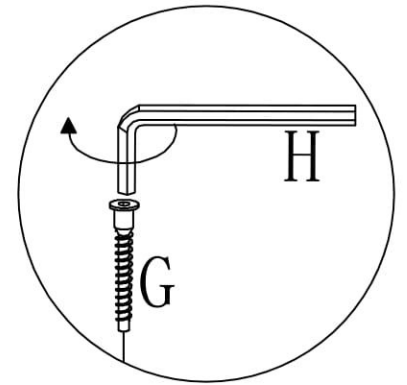
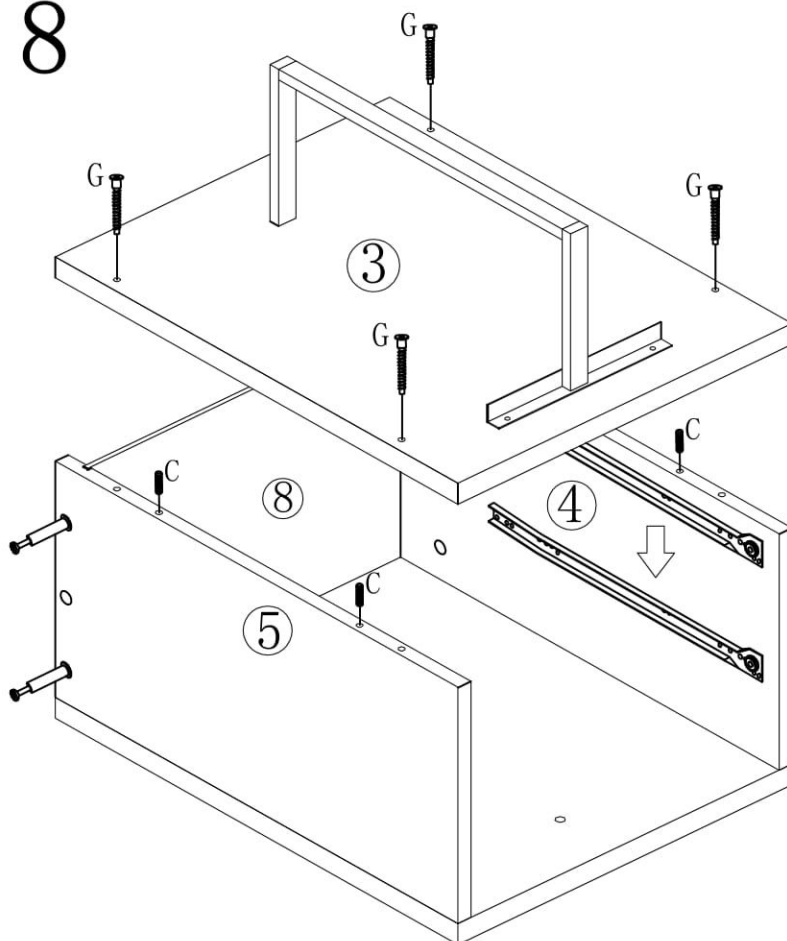

# STEP 8

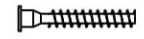

C	*4	G	X4
			
Φ 7.8X30		Φ 7X47	

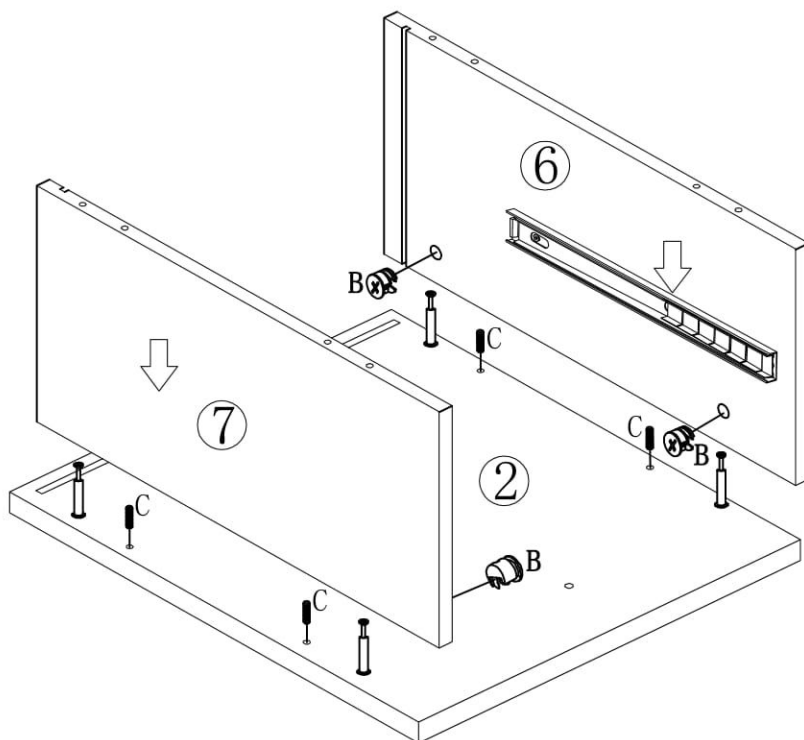
# STEP 9



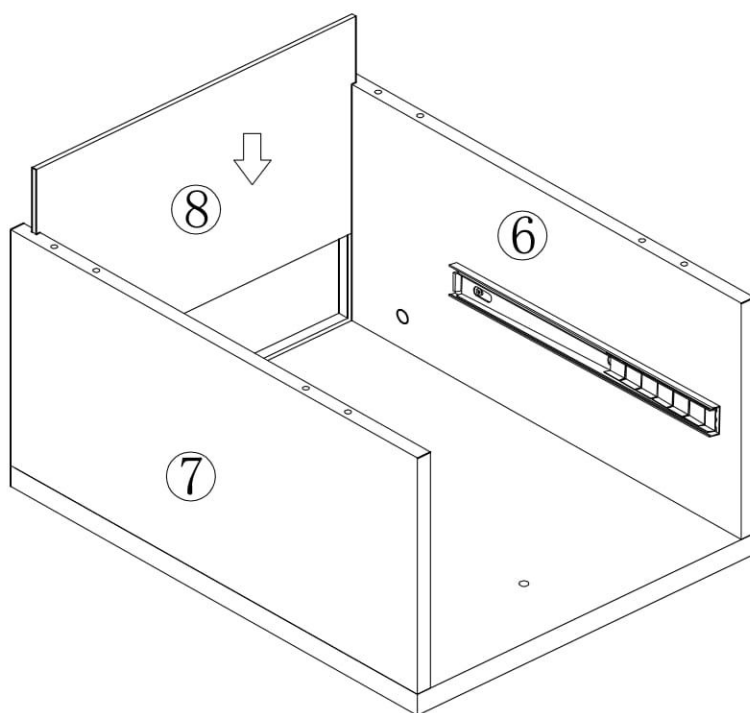

B	*4	C	*4
			
φ 15X12		φ 7.8X30	

# STEP 10



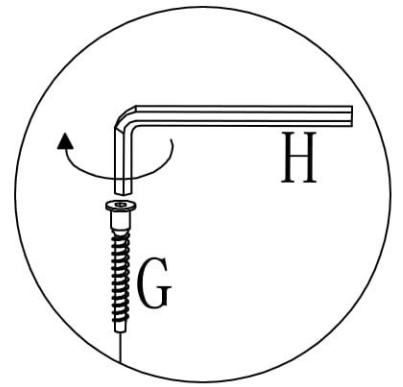
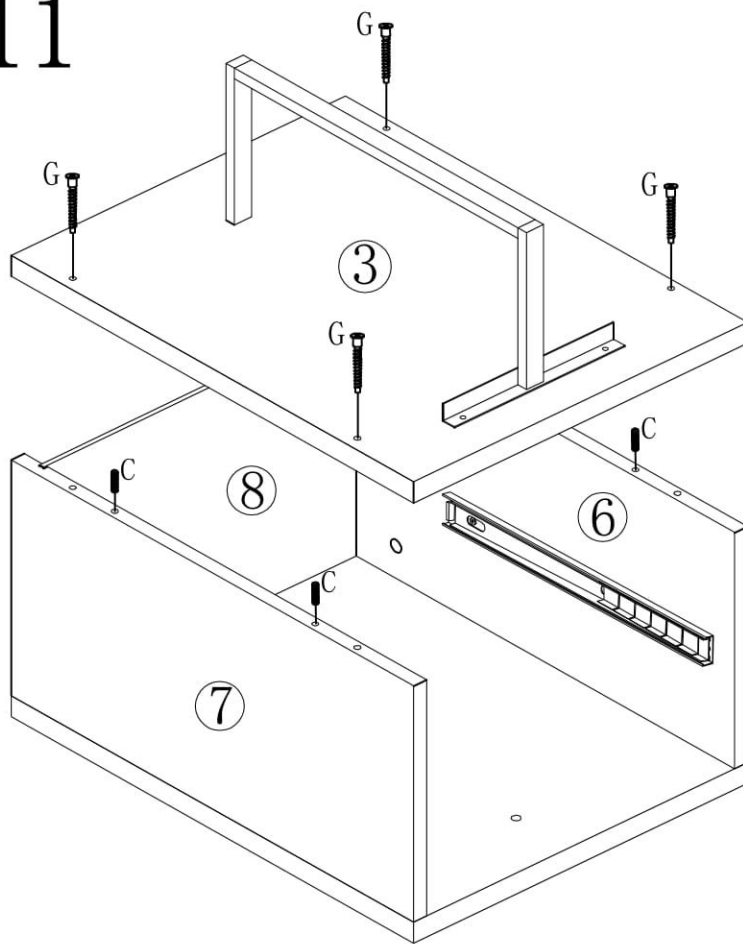

# STEP 11

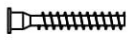

C	*4	G	X4
			
Φ 7. 8X30		Φ 7X47	

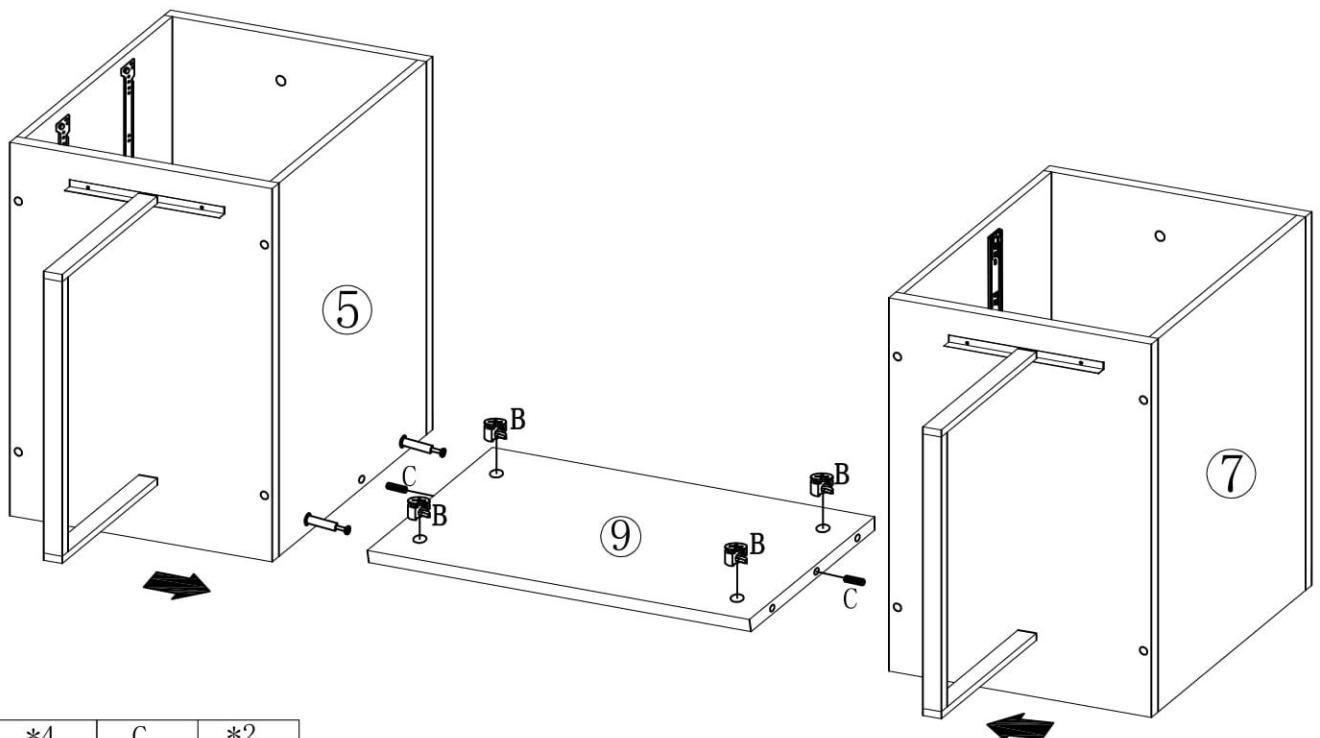
# STEP 12



B	*4	C	*2
			
Φ 15X12		Φ 7. 8X30	

# STEP 13

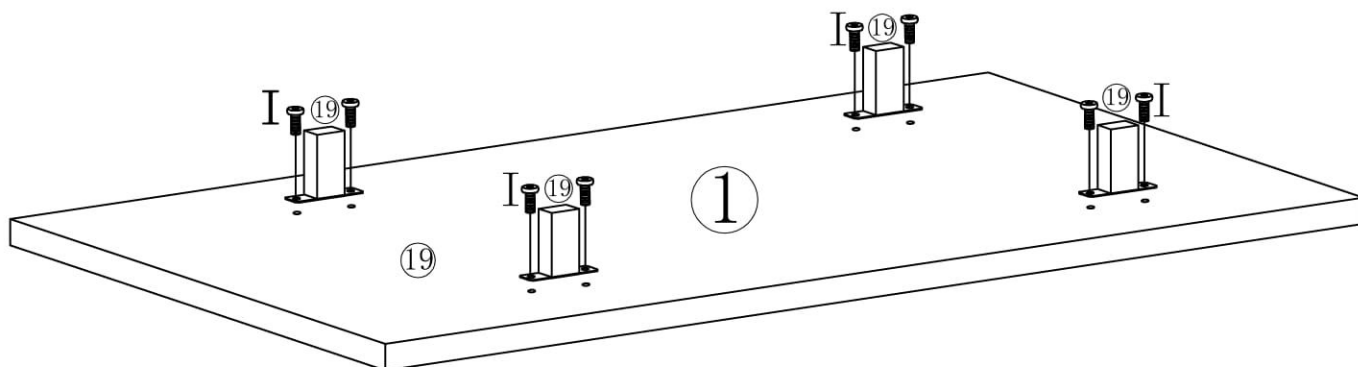
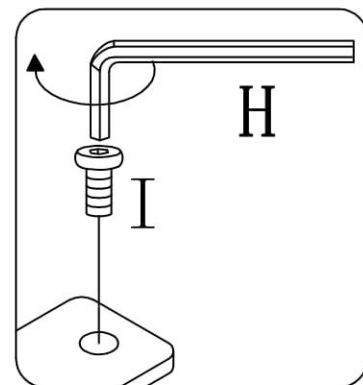

I	*8
M6*15mm	

# STEP 14

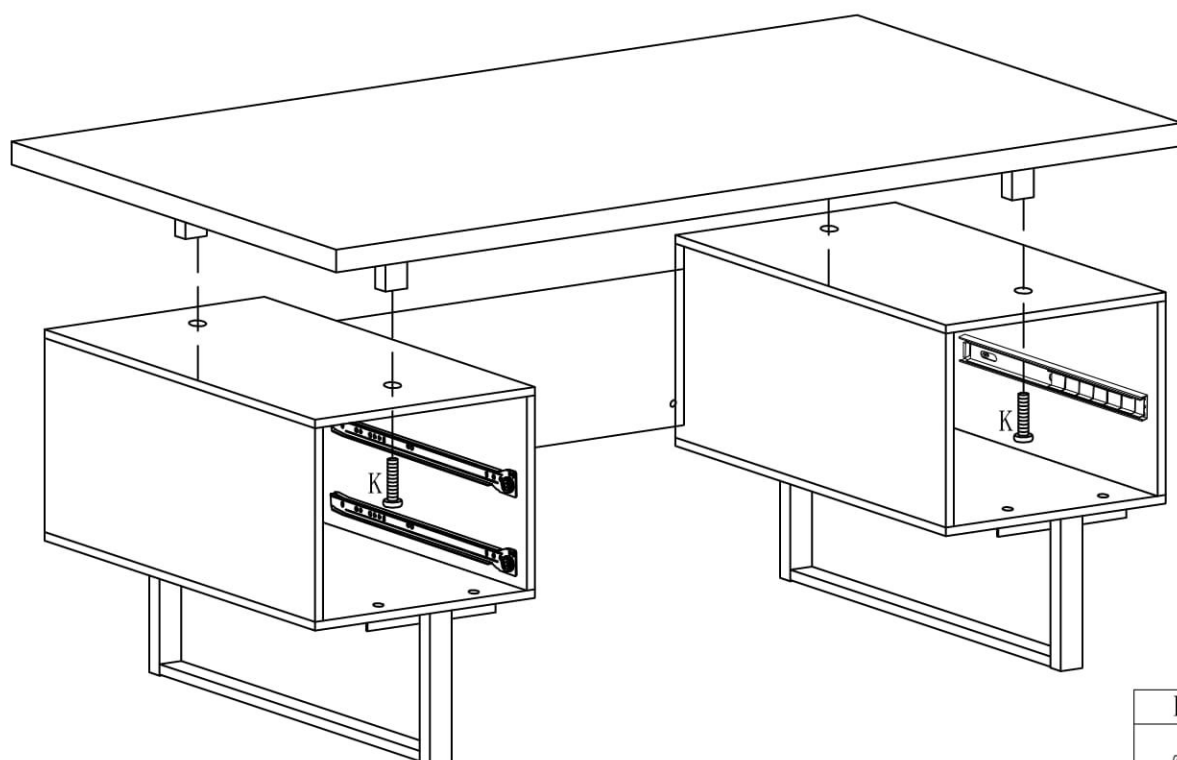

K	*4
M6*35mm	

# STEP 15

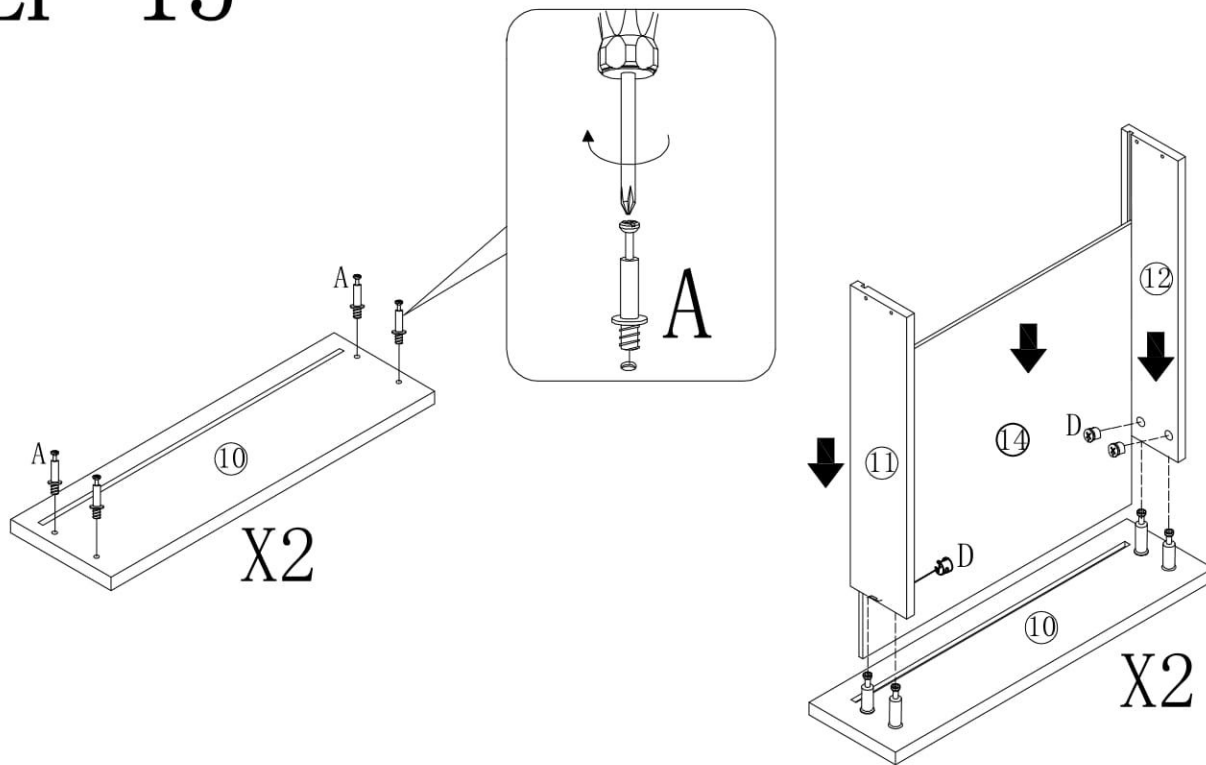

A	X8	D	X8
φ 6X35		φ 15X10	

# STEP 16

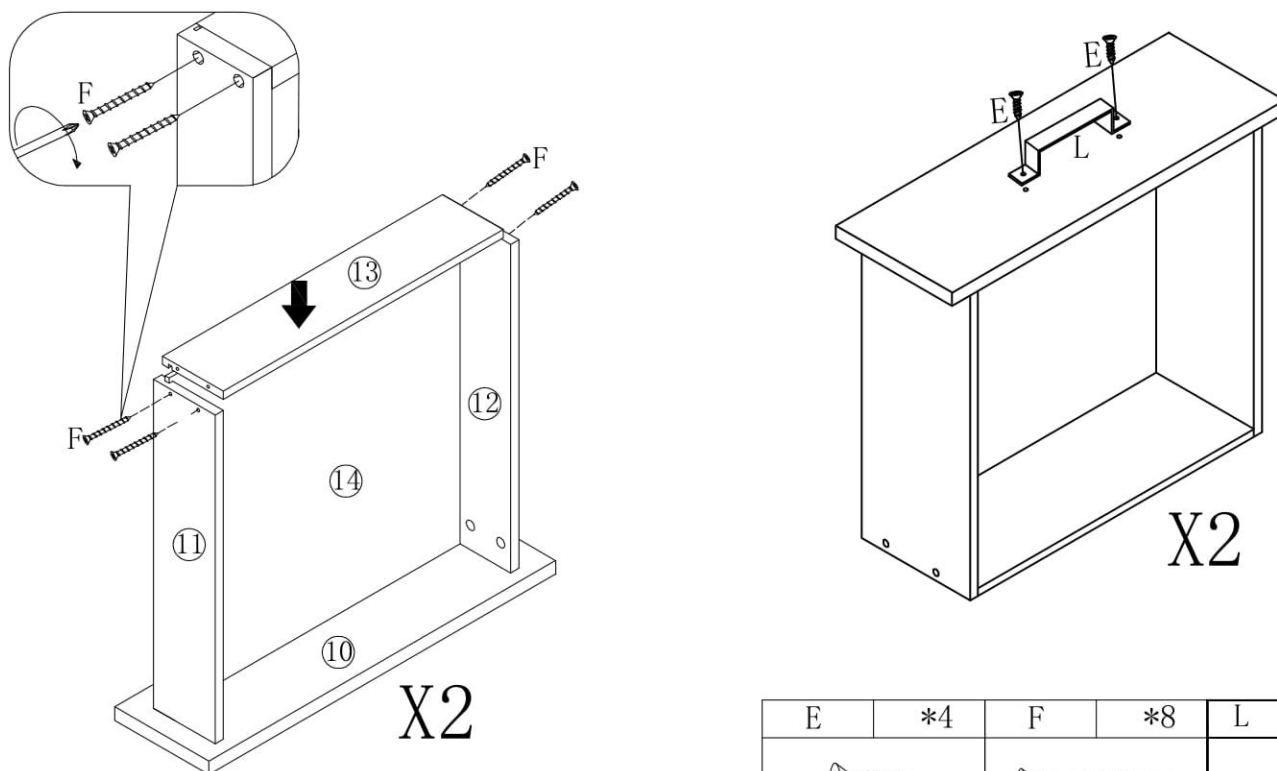

E	*4	F	*8	L	× 2
3.5*12mm		4*35mm		150*30*20mm	

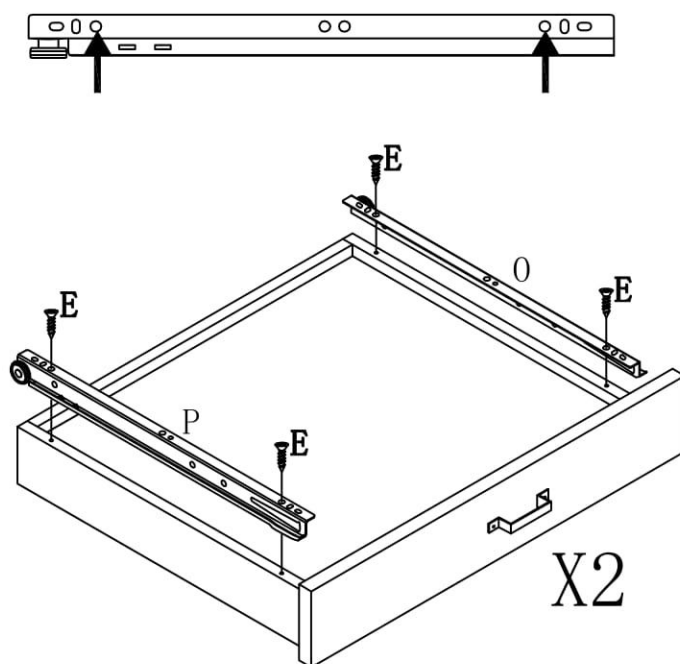

# STEP: 17



E	*8	O	×2	P	×2
					
3.5*12mm		L350mm		L350mm	

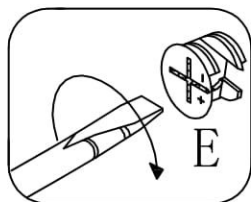
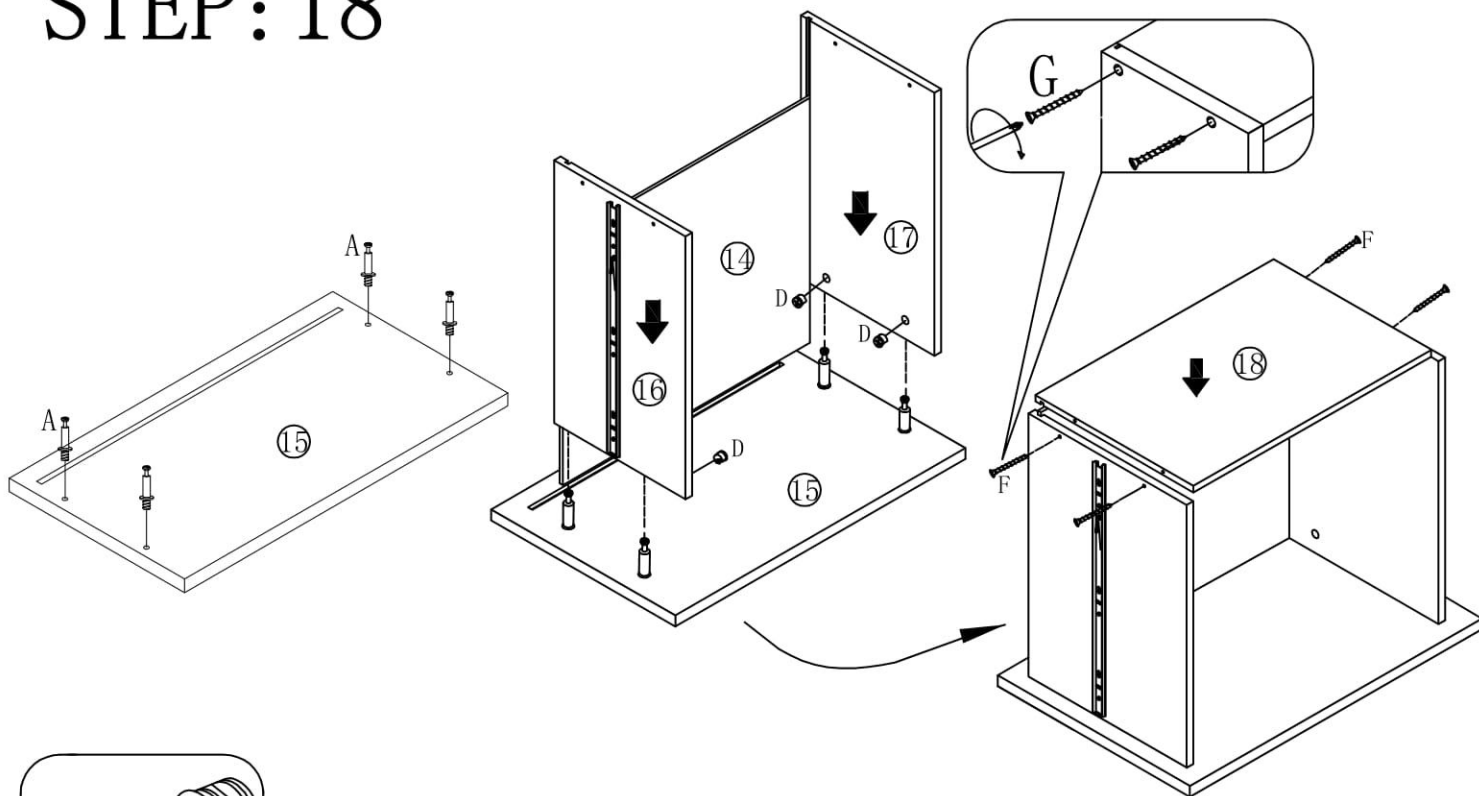

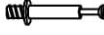
# STEP: 18

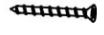

A	×4	D	×4	F	×4
					
∅6*35mm		∅15*10mm		∅4*35mm	

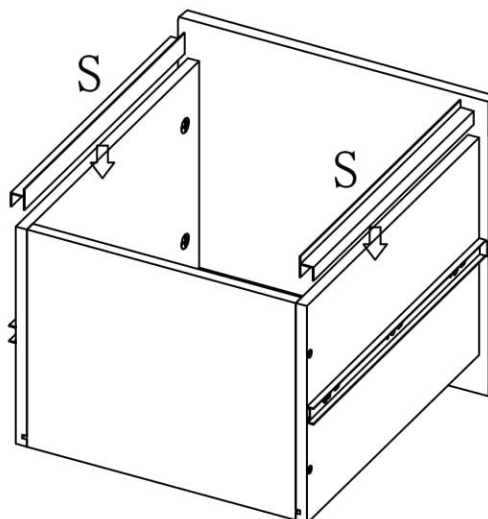
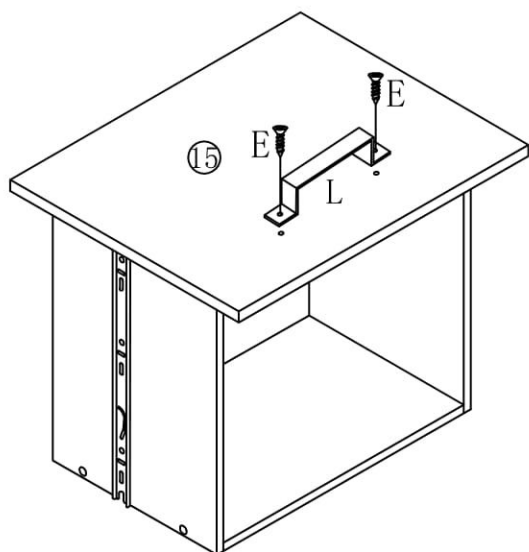
# STEP 19



E	×2	L	×1	S	×2
					
∅3.5*12mm		150*30*20mm		L336mm	

# STEP 20

