

Assembly Instructions

Product size: 277x319x198cm (9.1x10.5 FT)

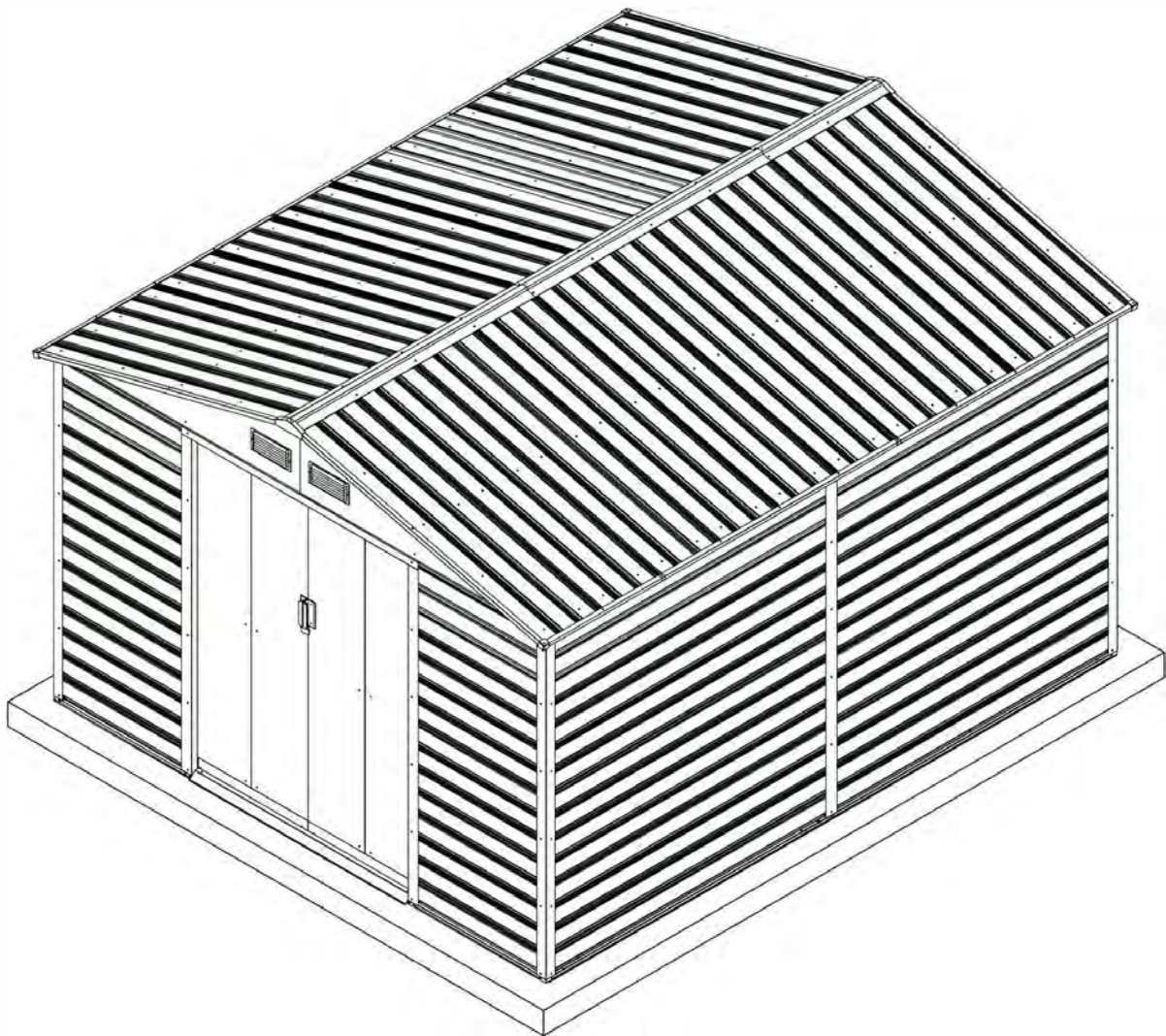

IMPORTANT TO FOLLOW THESE ASSEMBLY INSTRUCTIONS

Important, please retain for future reference.

Read carefully.

Requires two people and takes 5-6 hours for Installation.

Assembly Preparation

Before you begin:

Please check local building codes regarding footings, location and other requirements before beginning construction.

Reviewing all instructions and the appropriate information before you begin, make sure following the step sequence carefully for successful results.

Safety & Precautions:

- Select a suitable level ground that is suitable for the size of your shed at your property.
- The owner must use Safety gloves provided when erecting your shed (2 pairs are provided with your shed)
- Your shed is supplied in multiple boxes for safe handling
- Your shed is DIY shed. Do not attempt to assemble the shed on a windy day.
- It is recommended to plan at least one whole day for the assembly of your shed by 2 persons.
- A suitable ladder will be required to assemble your shed - we recommend you take necessary precautions to avoid injury.
- Be cautious with the tools used for the assembly of the shed .Familiarize yourself with the operation of all the power tools.
- For floor covering, the owner can purchase flooring material locally. We have supplied the foundation kit with the shed which can be used as floor base. Instructions about how to assemble foundation kit and how to fix flooring to the foundation kit are included in the manual.

Location and Base:

A good location for the storage building is a square and level area with good drainage.

The base is not included in the kit which may need purchase separately or may construct a foundation and anchoring system of your own. The recommended base size about 10 cm larger than the bottom rail of the shed.

A strong plastic sheet (thickness: at least 150µm) should be placed under the foundation to assist in reducing rising dampness from the soil, thus reducing condensation build up in the shed.

Your storage building **must be anchored** to prevent wind damage. Once secured, it is highly recommended applying silicone along the inside of the base rail to minimize condensation.

Parts and Parts List:

Before you start, separate and identify all the parts and hardware to be sure that you have all the necessary parts for your building (refer to the Parts List Page).

Do not attempt to assemble the building if parts are missing because any building left partially assembled may be seriously damaged by light winds.

Personal **Tools you will Need:**

(Please tear off the safety protection layer before the assembly, keep the part number label if needed)

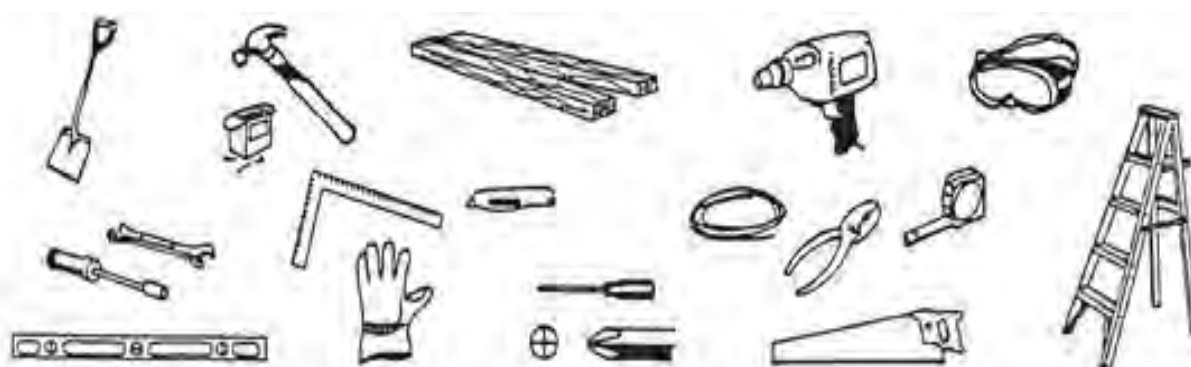

Safety must be put in the No. 1 position:

1. Select a dry and calm day for your assembly.
2. Team works (2 or more people) are required during the assembly. It is also recommended to finish the assembly in a day to avoid damage to the product or missing of some small parts.
3. Wearing safety gloves, eye protection and long sleeves during the assembly to prevent injury. Pay attention to the sharp edge of some parts.
4. Children and pets are not allowed entering into the construction site.
5. Never concentrate your total weight on the roof of the building.
When using a step ladder make sure that it is safe.

Care & Maintenance:





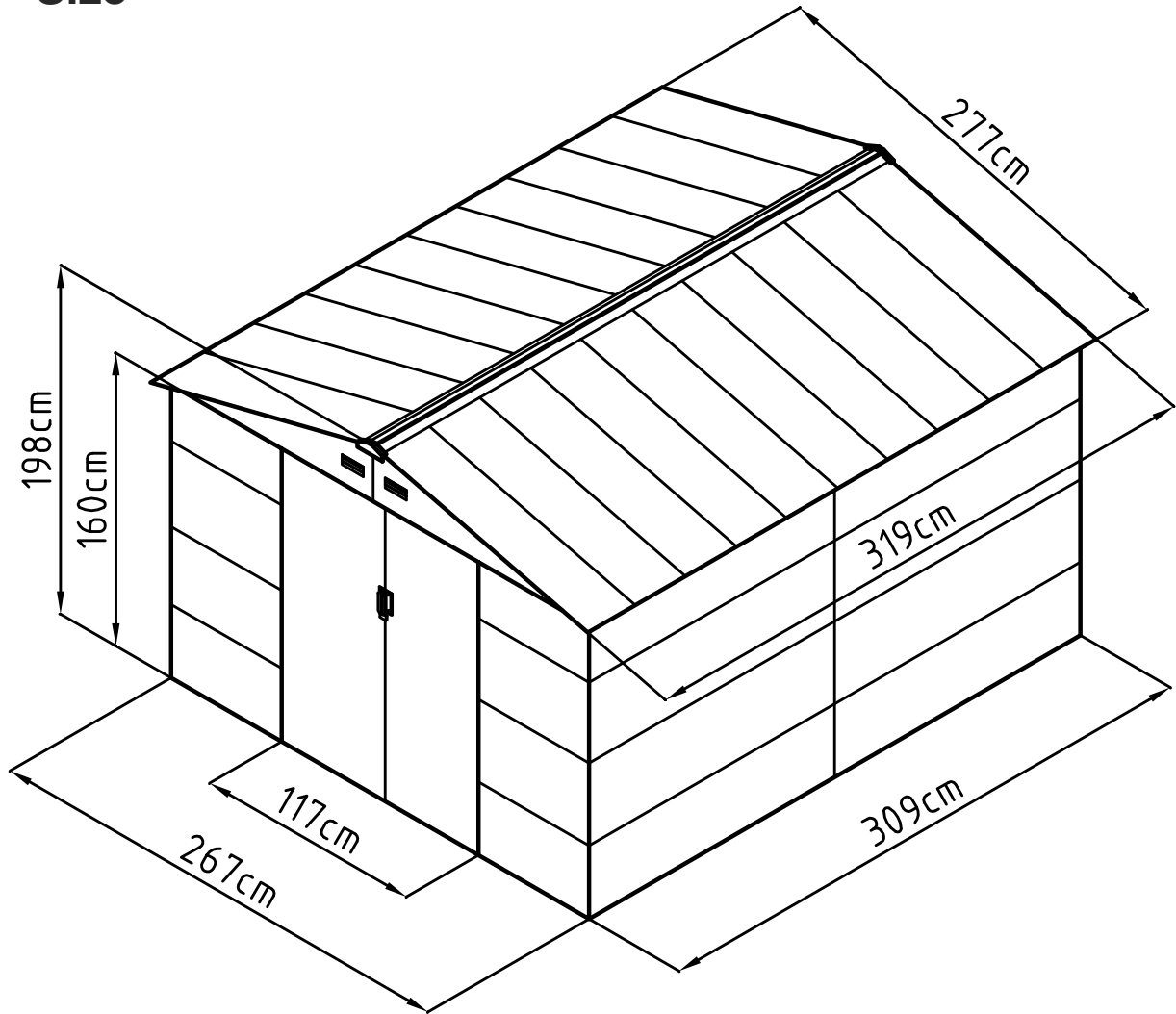



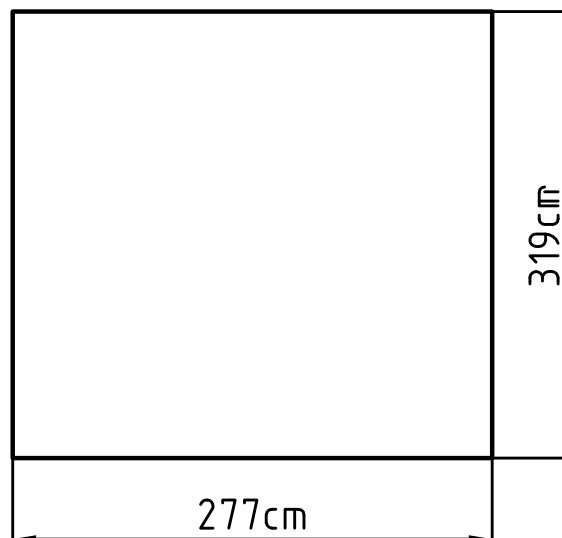





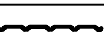

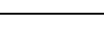







1. Keep the shed clean with soft cloth, use water if necessary.
2. Keep the door tracks clear of dirt and other stuff that prevent them from sliding easily.
3. Clean the snow with necessary tools to make sure it is safe to enter into.
4. The shed is not made for living but storing stuff.
5. Please add some oil on the top and bottom door sliding channel to make door slides smoothly.















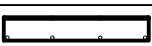









Size



Area of installation requirement



NO.	IMAGE	mm	QTY
UNDER			
Es-C1		1475	x1
Es-C2		1293	x1
Es-E3		1709	x2
Es-E3a		1486	x2
Es-C4		803	x1
Es-C5		803	x1
Bs-B6		1171	x1
MIDDLE			
Em-C7		674	x6
Es-C7a		674	x2
Em-E11		1497	x12
Es-E11a		1497	x4
Em-C14		1283.5	x6
Es-C14a		1283.5	x2
Em-8		1630	x4
Es-C9		1315	x1
Es-C10		1315	x1
Es-C12		1500	x1
Es-C12a		1230	x1
Es-E13		1739	x2
Es-E13a		1443	x2
Em-15		1630	x3
Es-15a		1615	x3
Em-16		1630	x1
Em-16a		1630	x1
Es-17		1615	x1
Es-17a		1615	x1
Es-C18		1279	x1
Es-21		1615	x4
Em-E46		1615	x6
TOP1			
Ax-B19		1305.3	x2
Ax-B20		1305.3	x2
Ax-B21		1271	x4
Ax-A22		1170	x4
Ax-C22a		1489.5	x4
Ax-22		850.5	x4
T-X29			56
Ax-B29		166	x4
Ax-B45		272	x4
Ax-B49		256.5	x2

NO.	IMAGE	mm	QTY
TOP2			
Am-C23		1420	x2
Am-C24		1420	x14
Am-C24b		1420	x1
Am-C25		1420	x2
Am-C24p		1420	x1
Am-26		1296	x4
Am-27		657	x2
As-C38		1418	x2
As-C39		1418	x2
Am-A28		1298	x2
Am-B28		659	x1
DOOR			
Em-C30		1550	x1
Em-C35		1550	x1
Em-C30a		1550	x2
Es-31		1550	x2
Em-31a		1550	x2
Ax-B32		287.5	x4
Ax-B32a		265.5	x4
Ax-B33		593	x1
Ax-B34		593	x1
Ax-B36		593	x1
Ax-B37		593	x1
			593
ANNEX			
T-P1			x4
T-P2			x4
T-P3			x4
T-P4			x2
TP5A			x4
T-P6			x2
T-P7		200	x1
T-P8			x2
Em-C40			x385
Em-C41			x452
Em-C42			x23
Em-C43			x210
Em-C44			x170
		40mm	x1
			x2
V-A1		1024	x8
V-A3		1344	x6



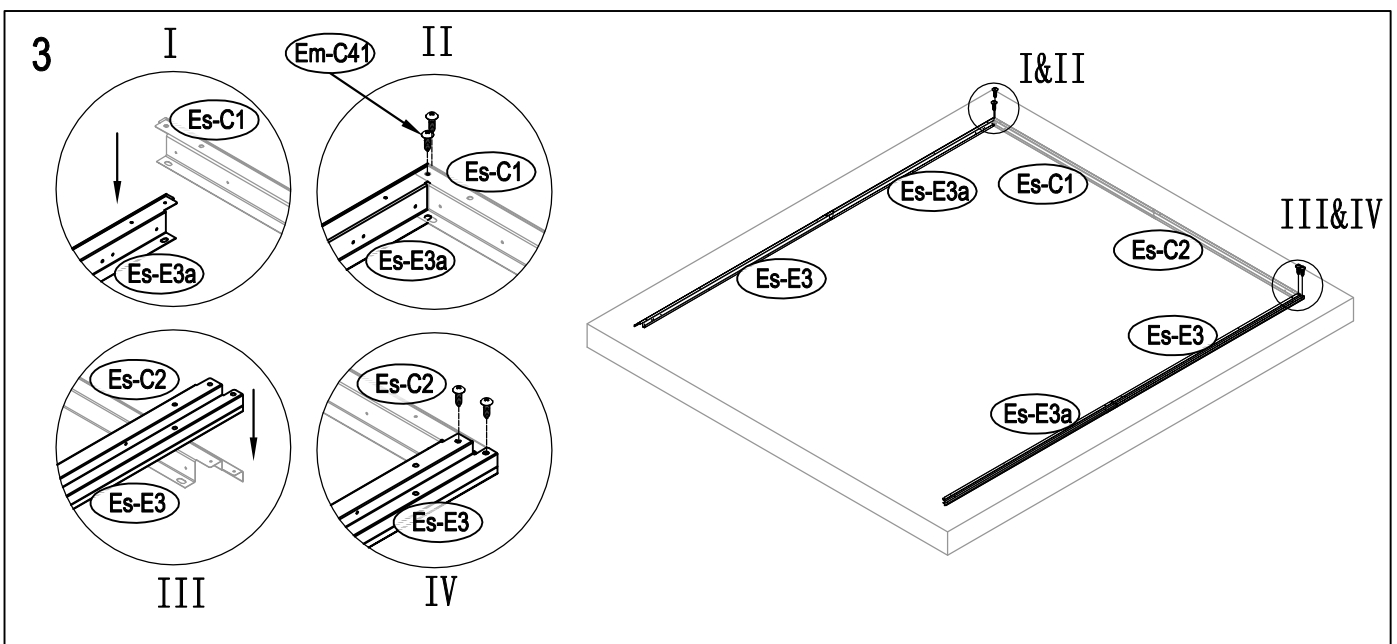
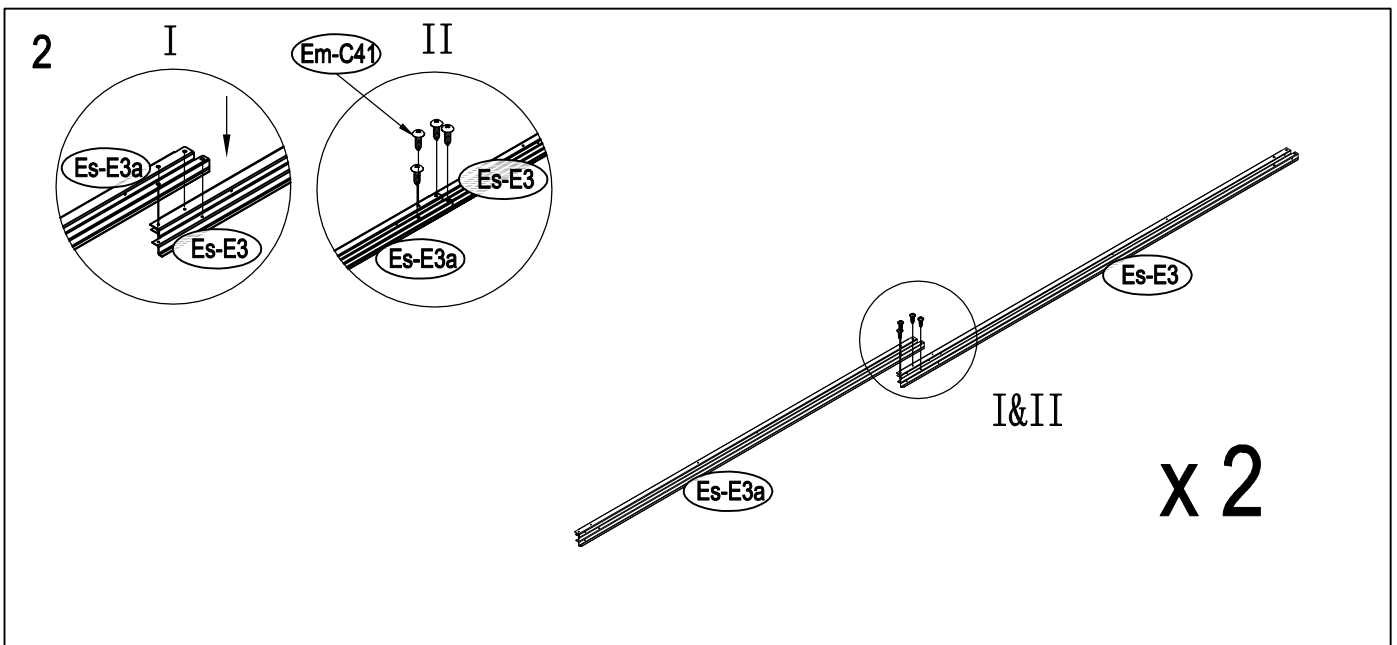
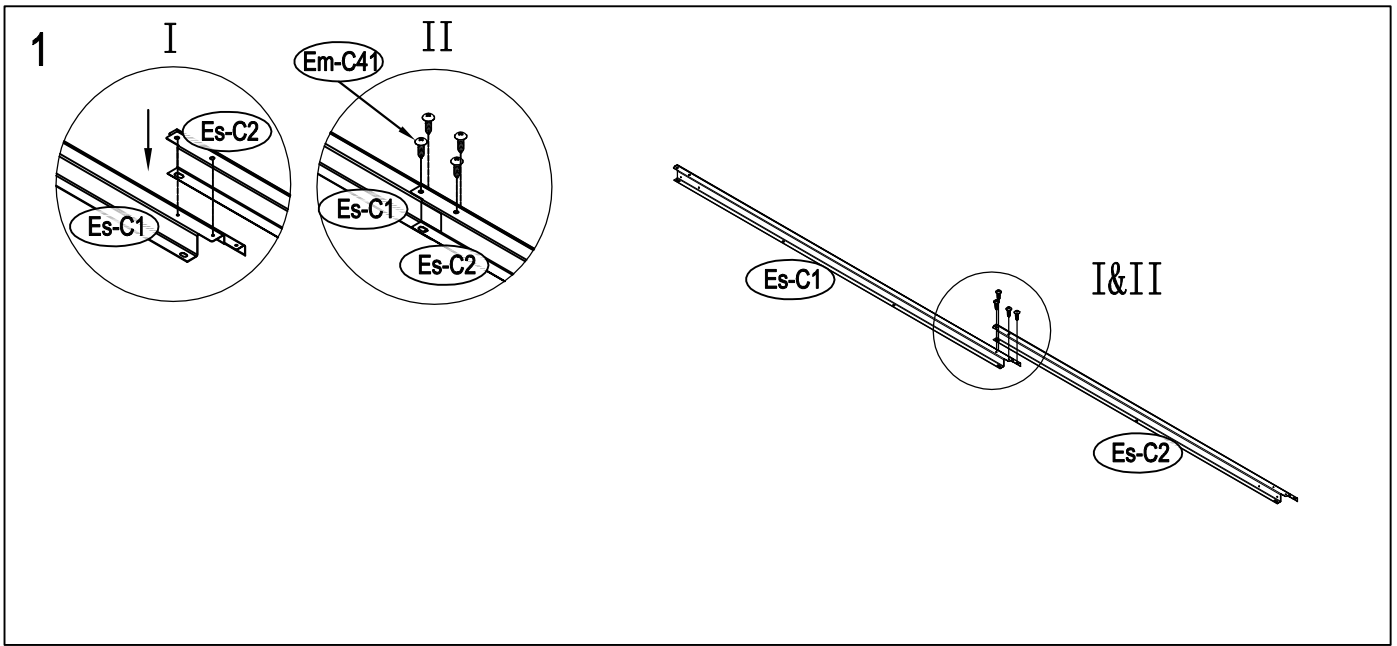

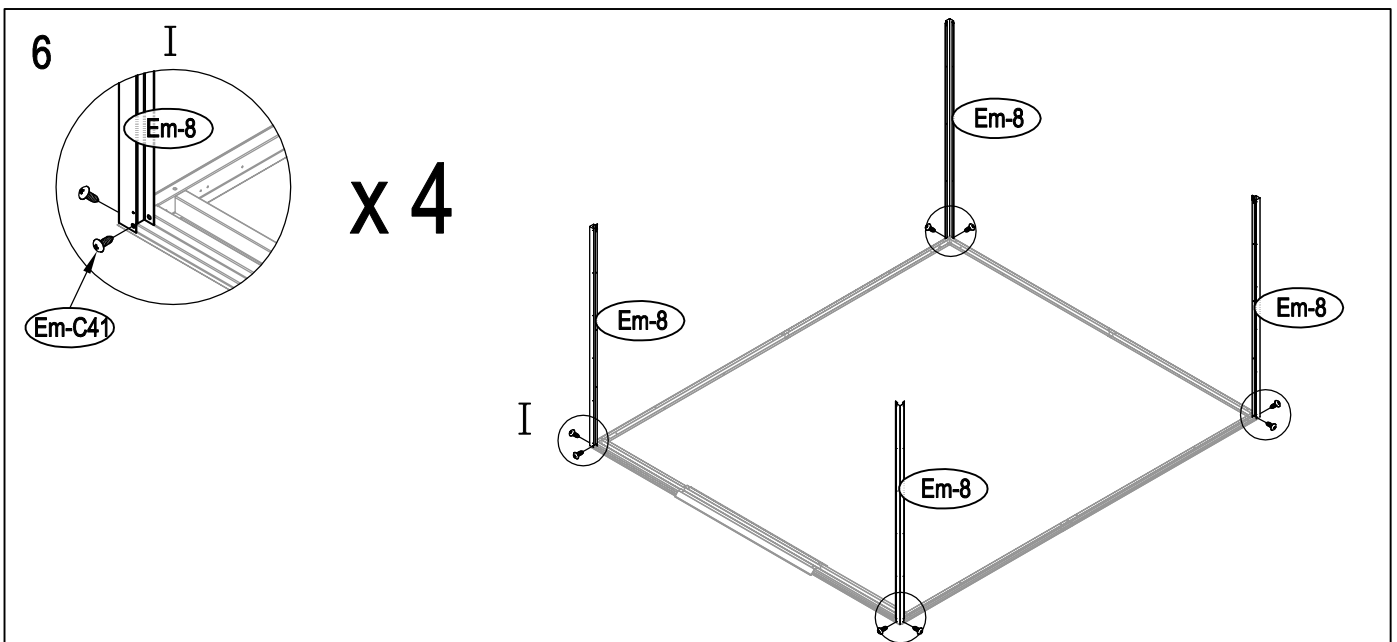
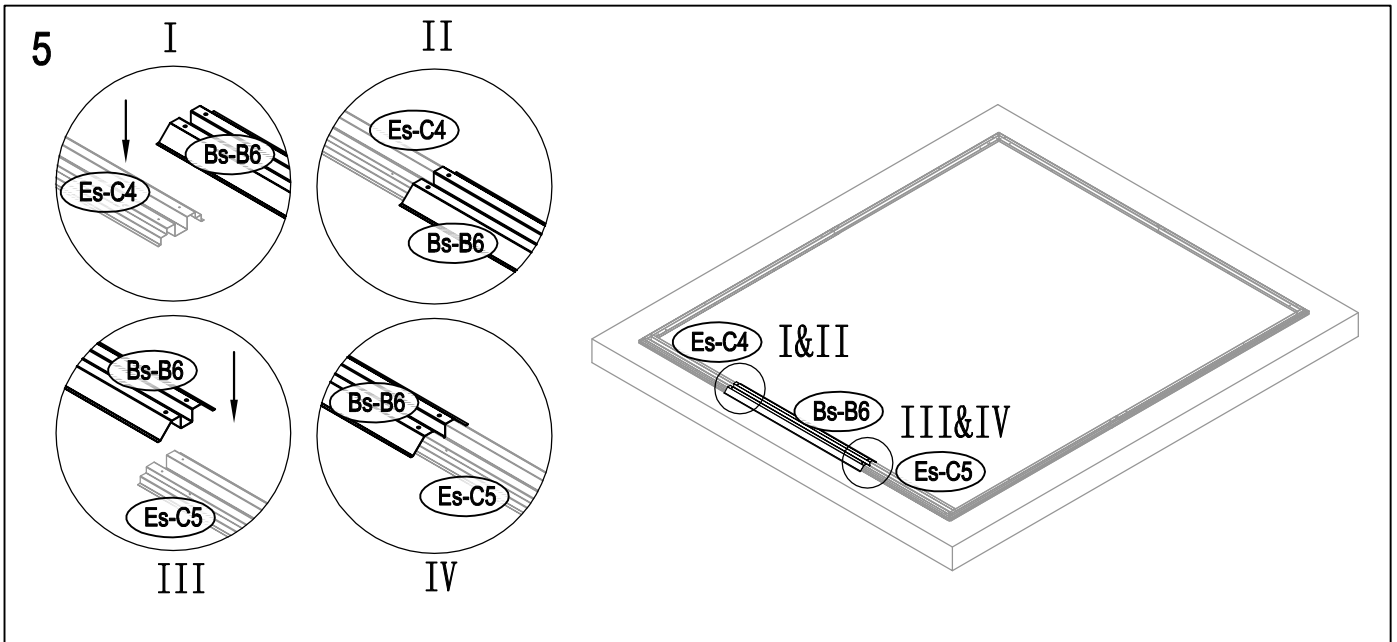
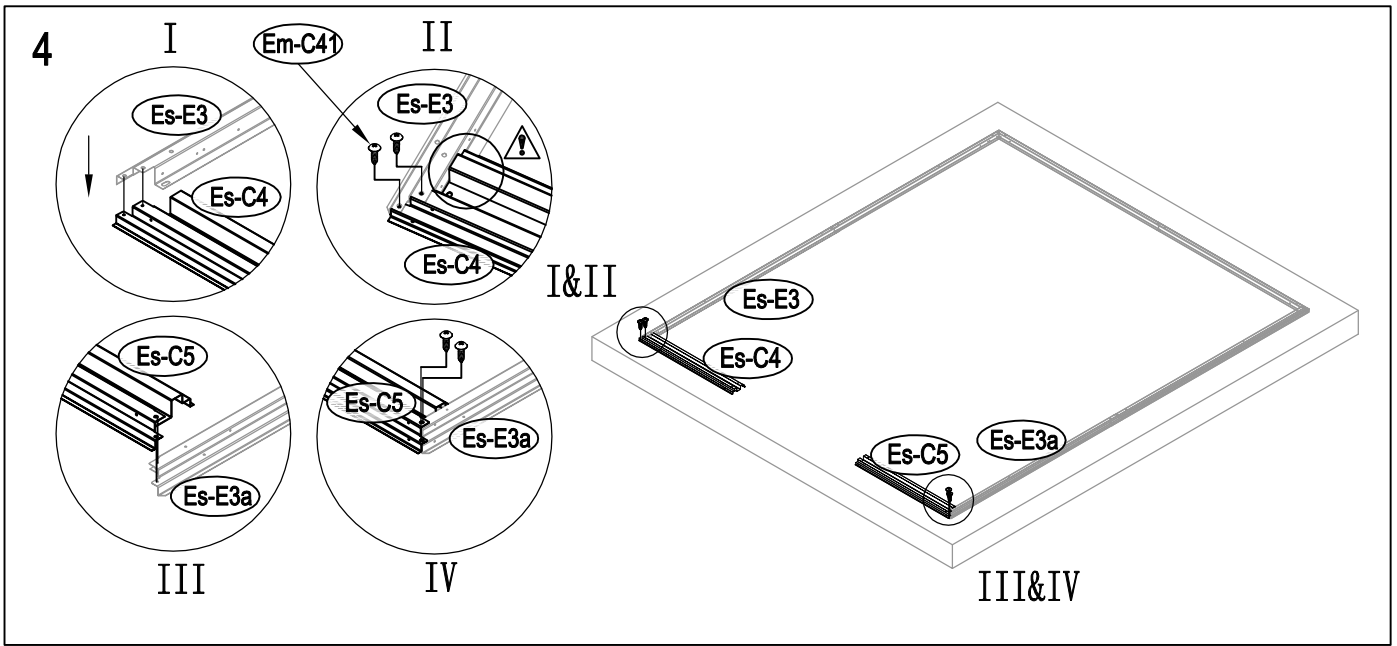

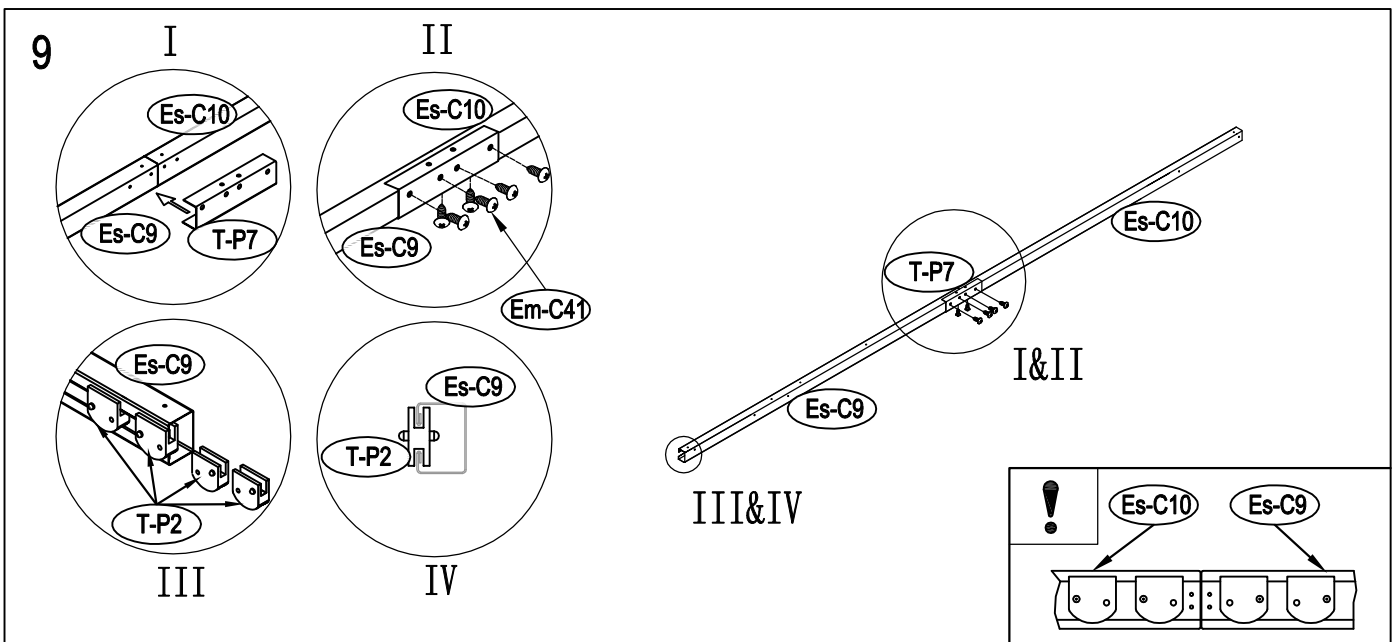
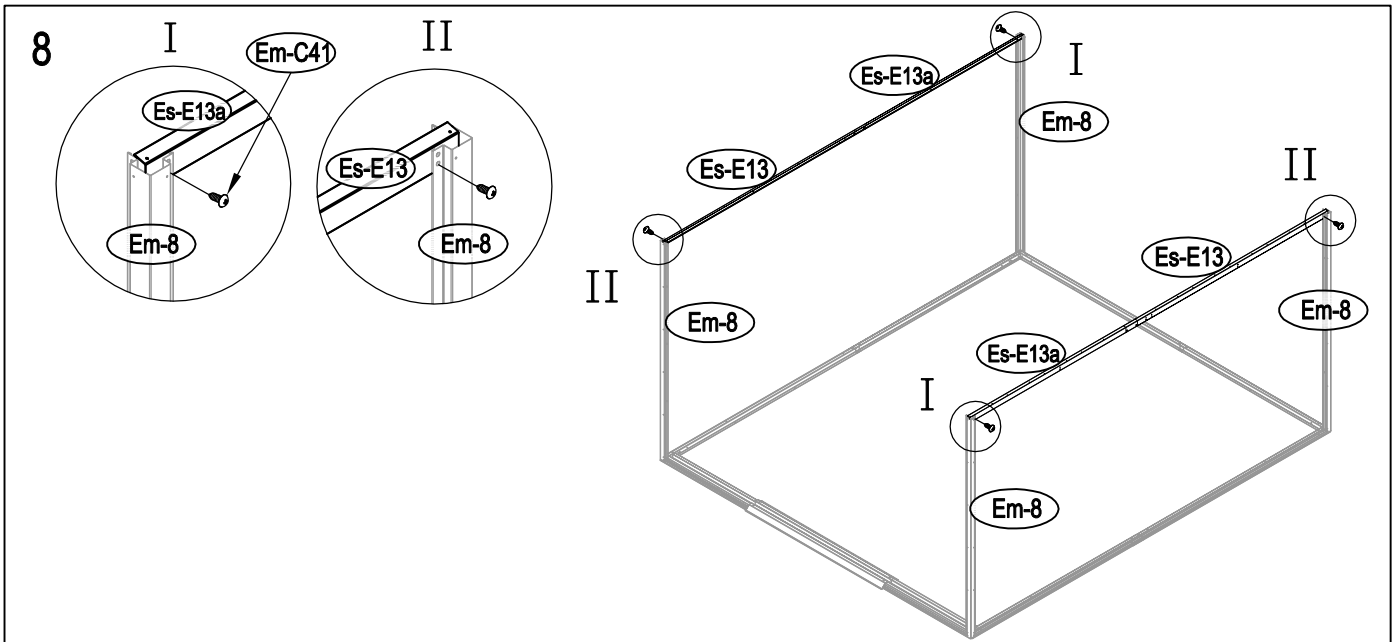
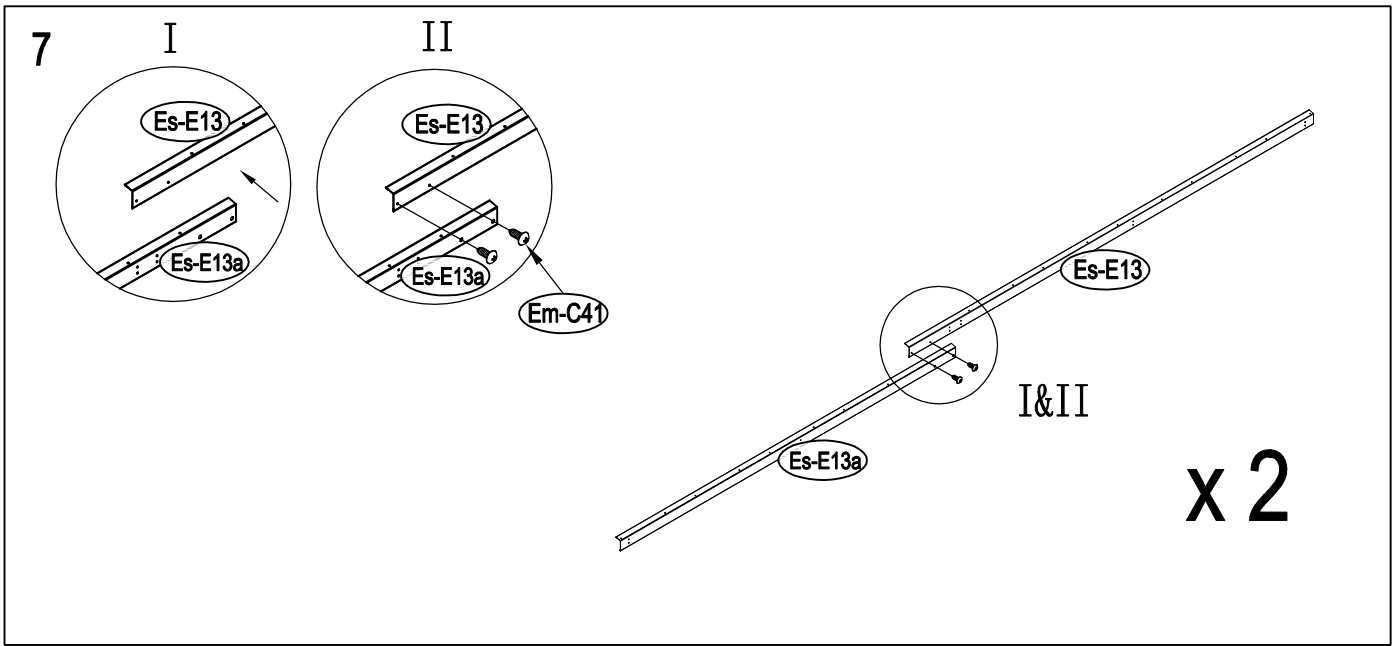

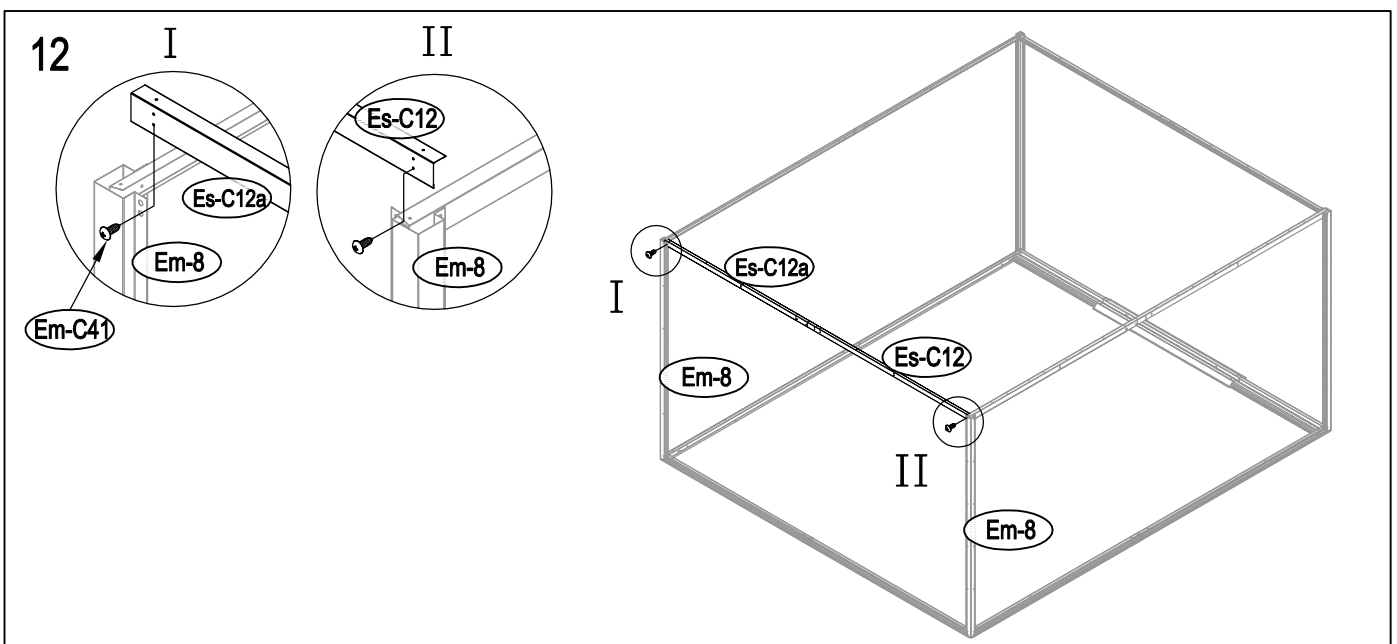
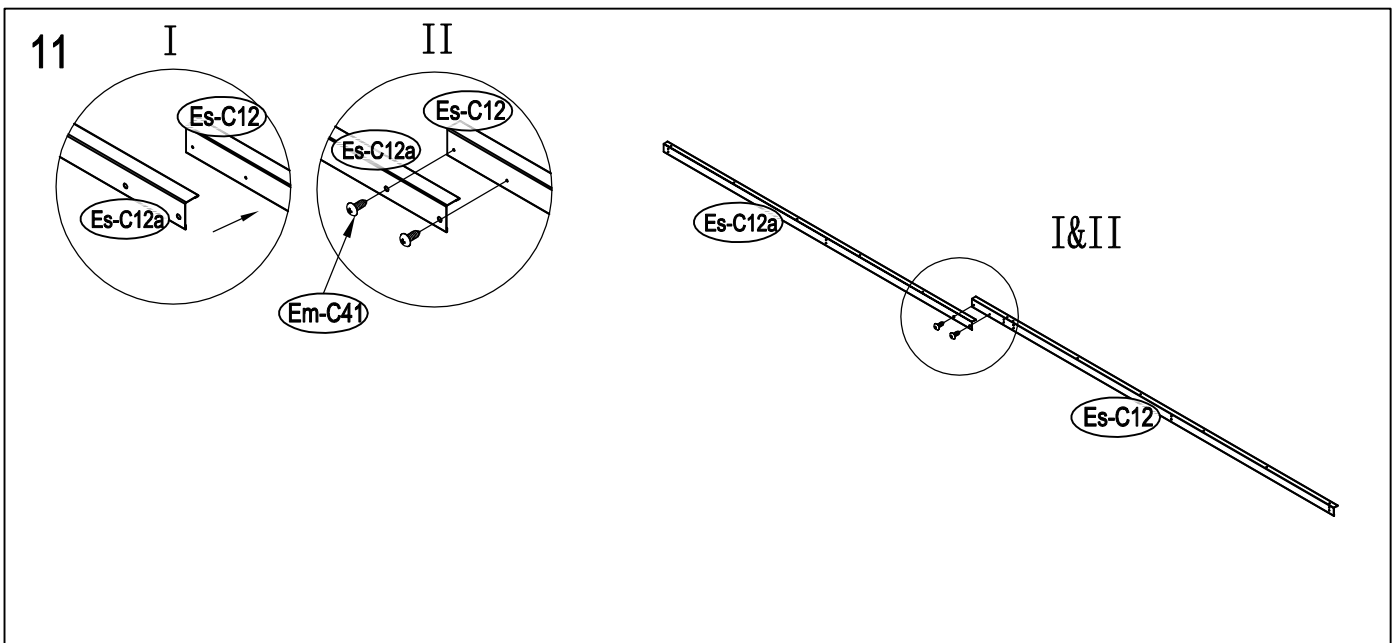
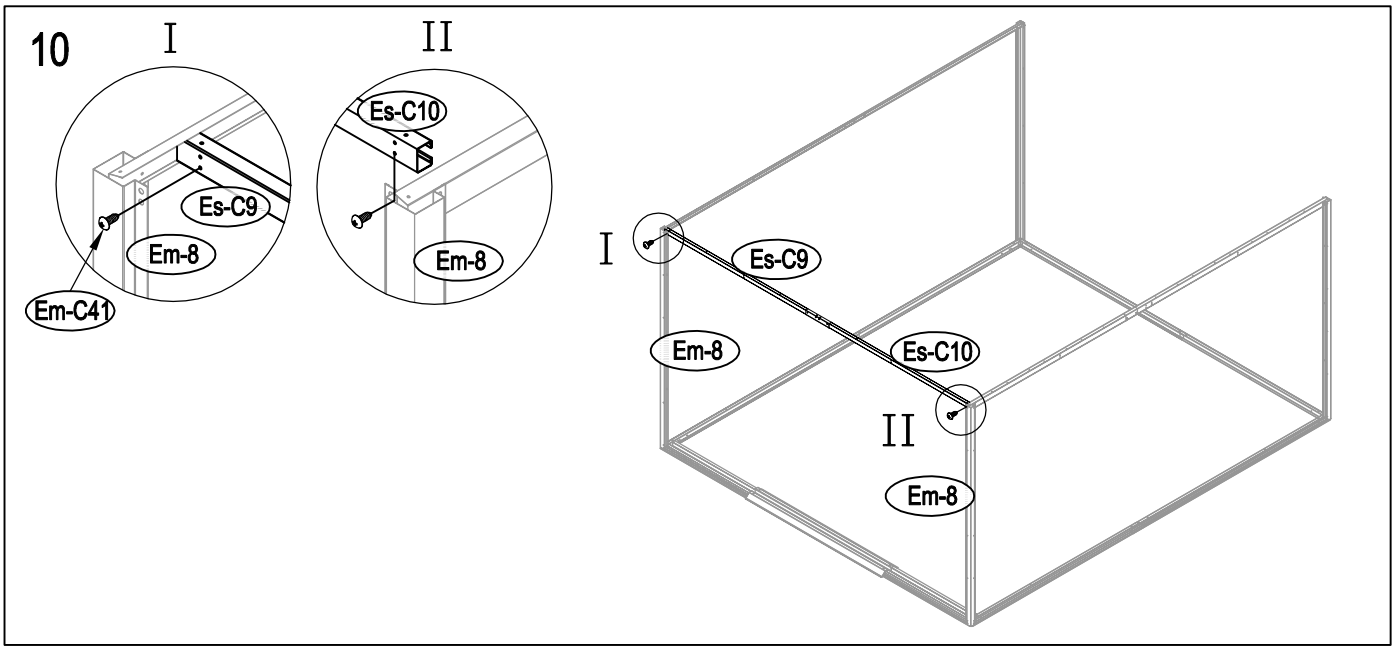

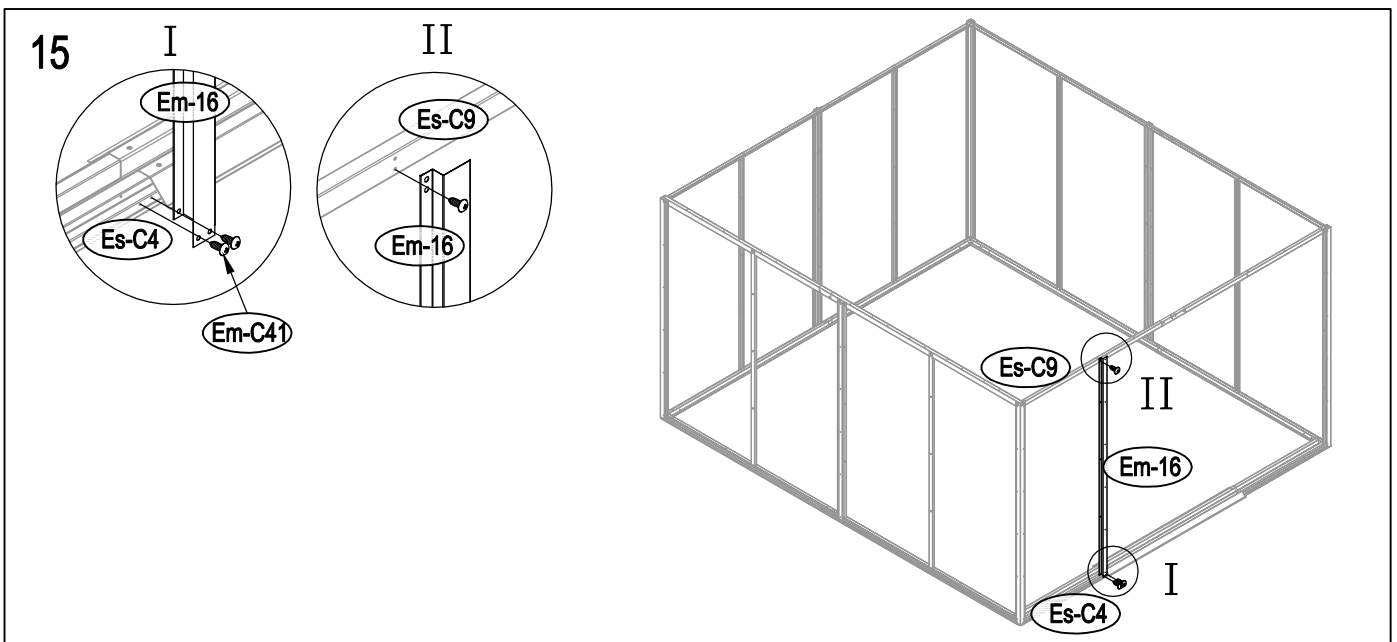
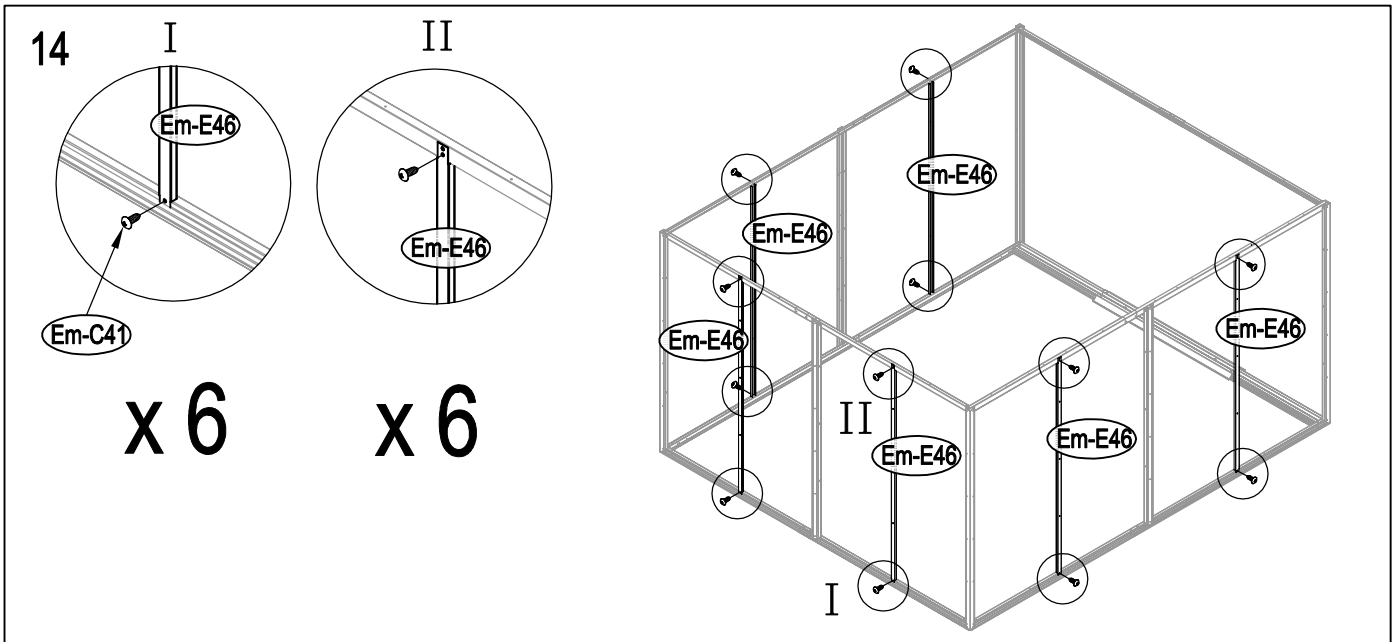
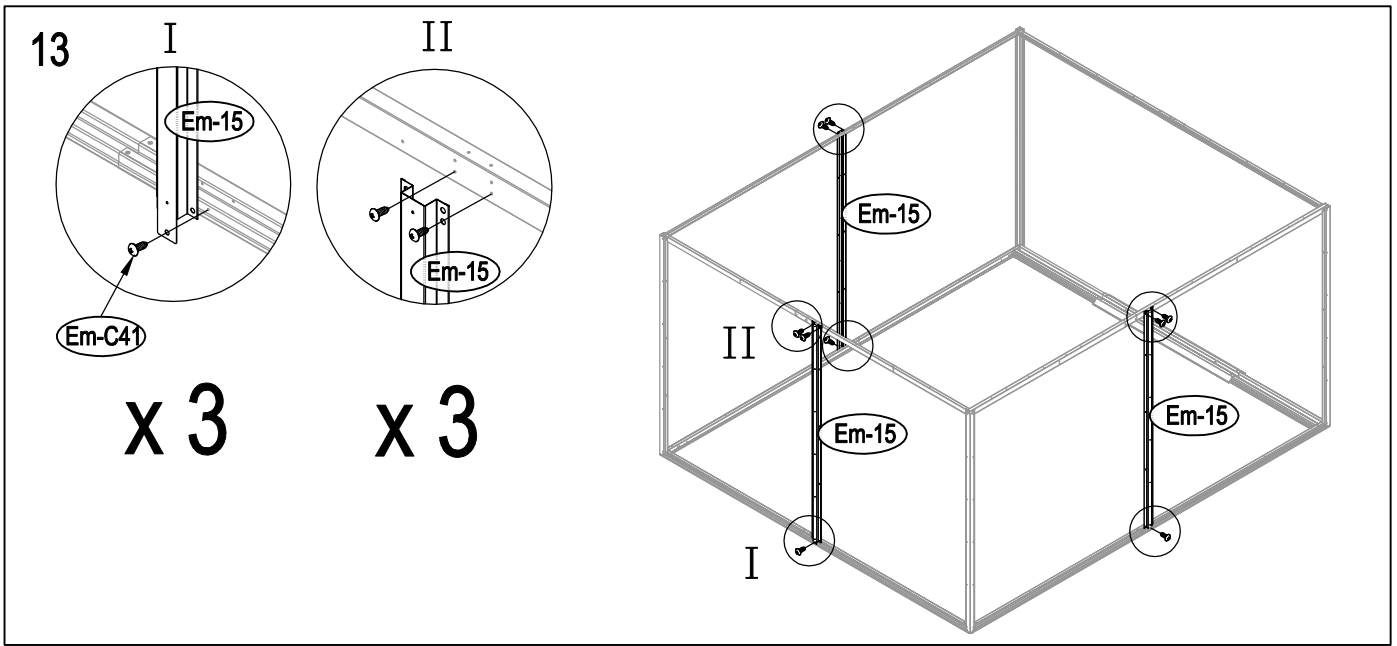

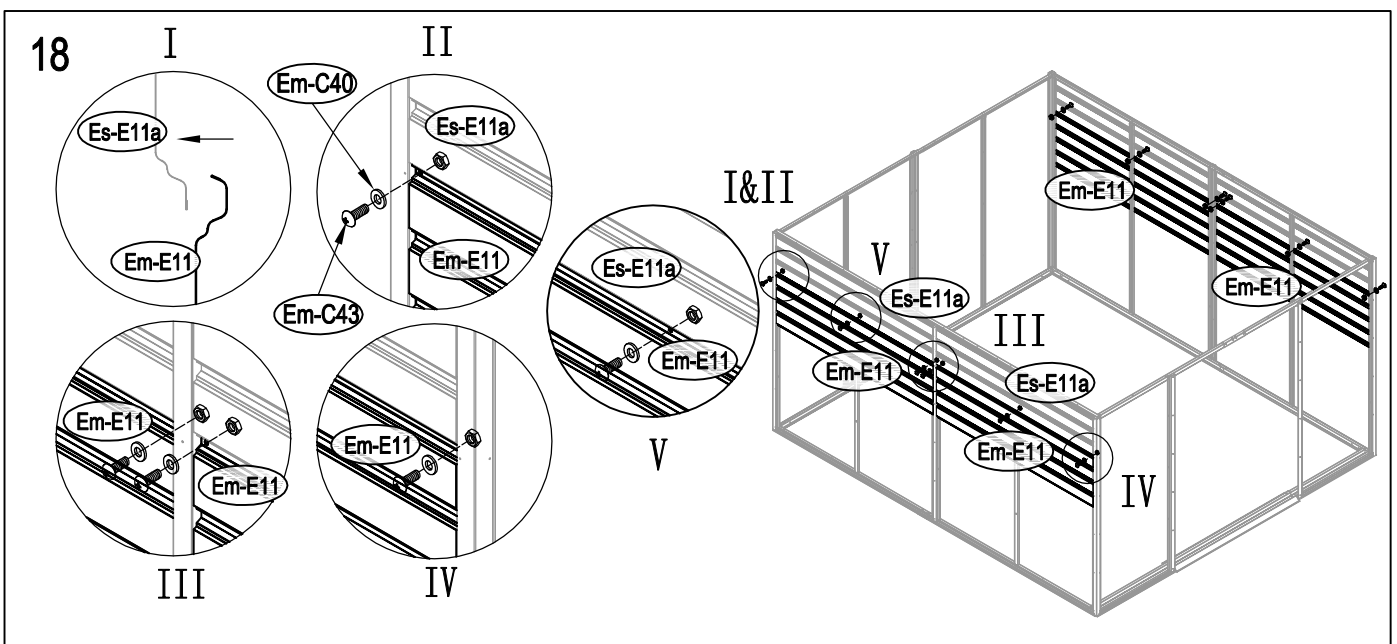
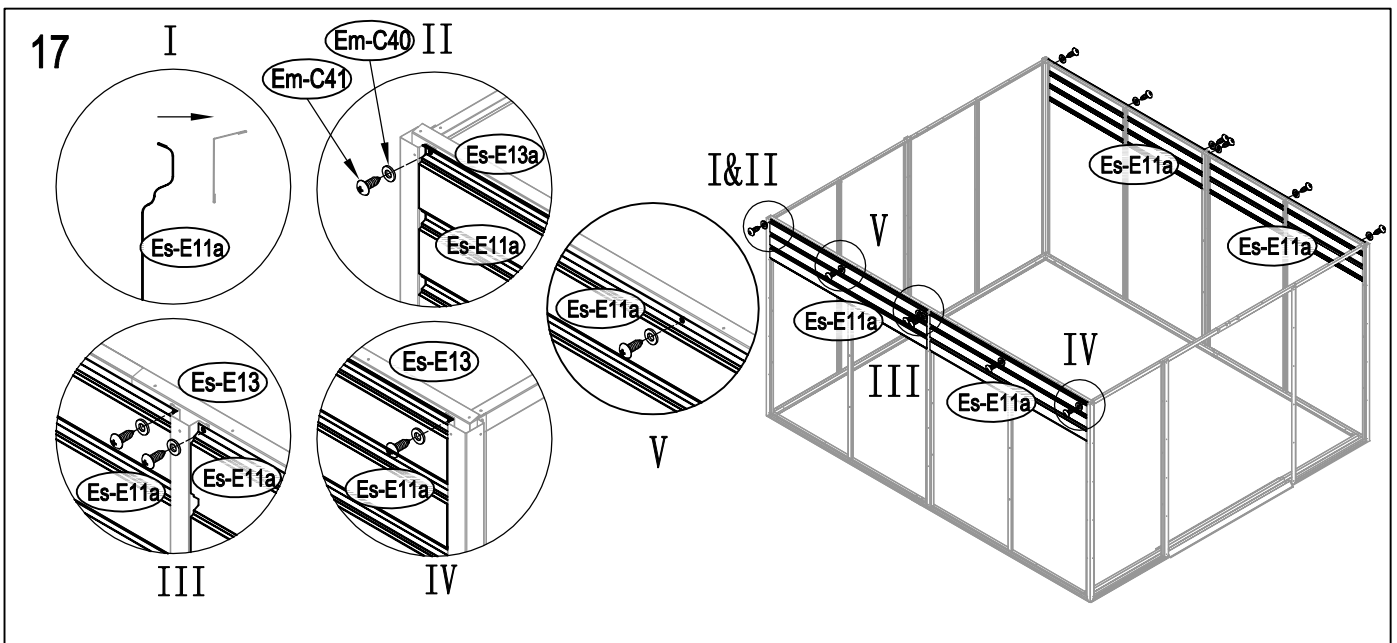
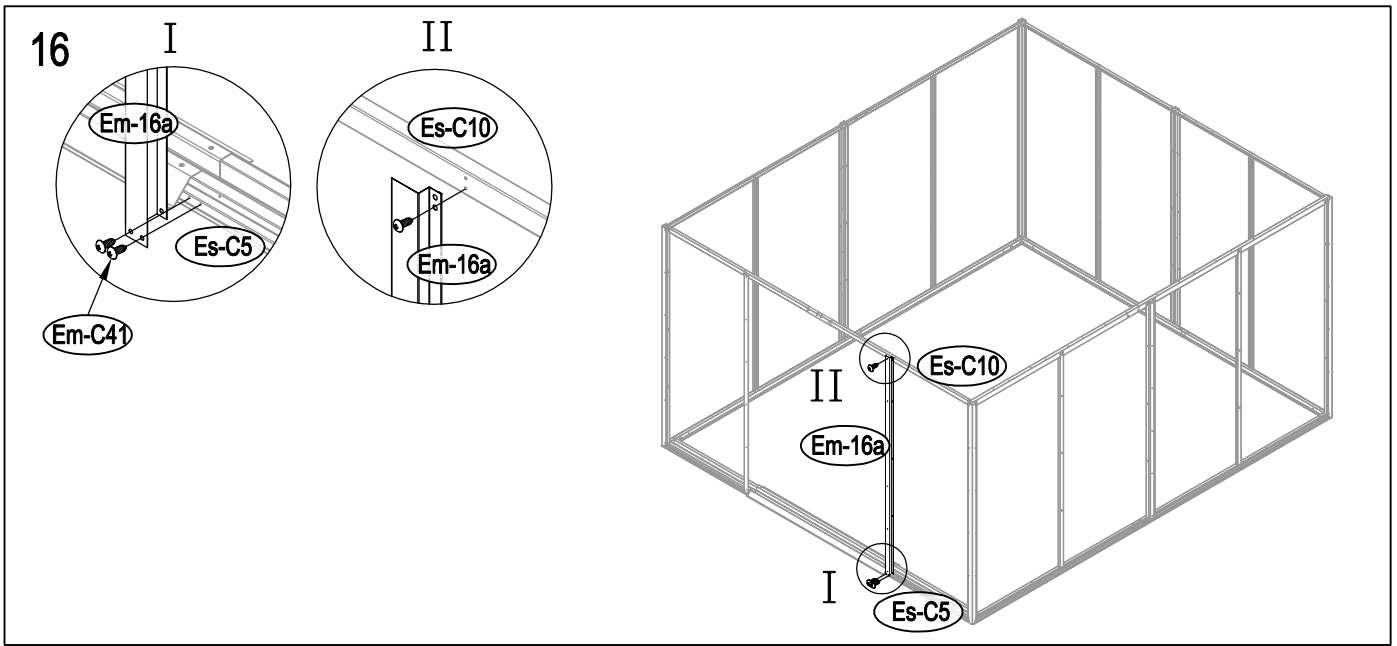

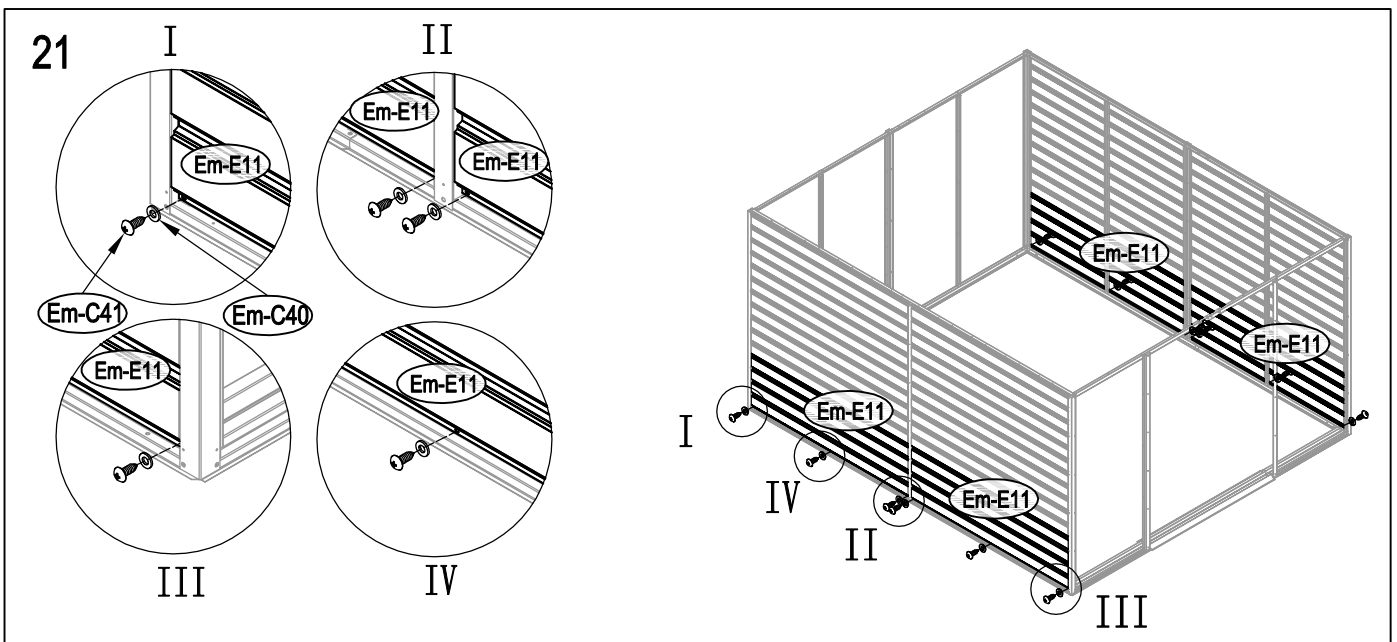
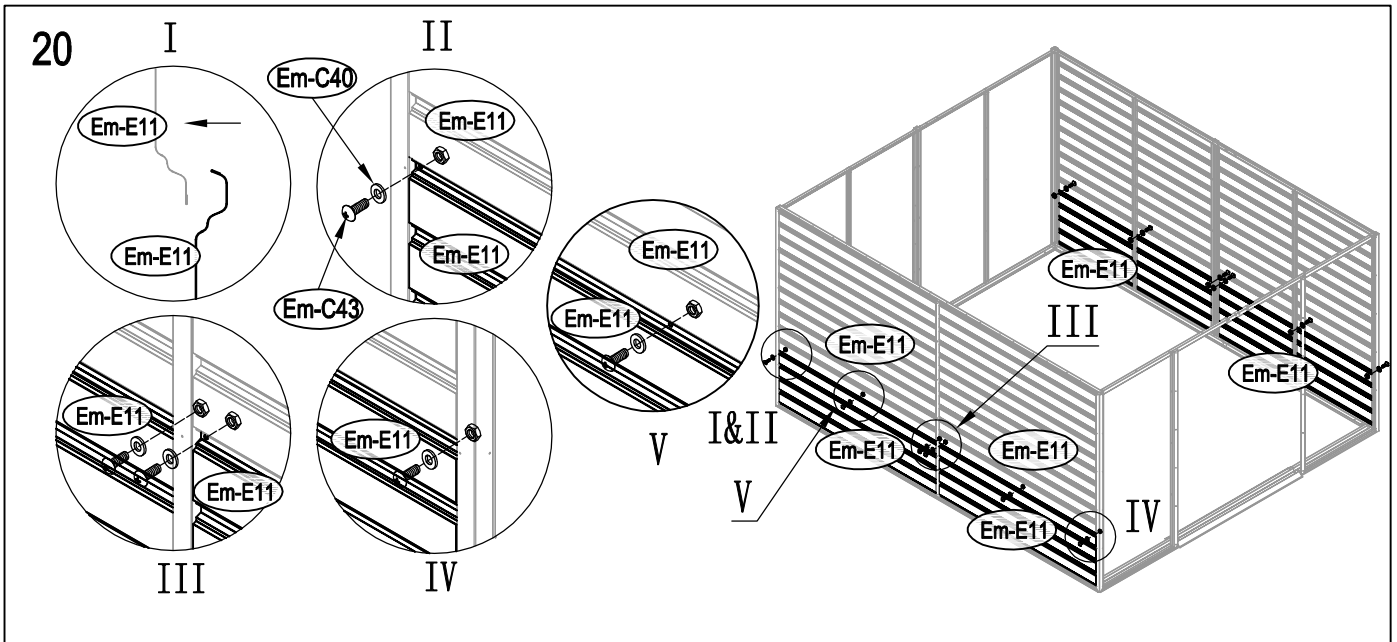
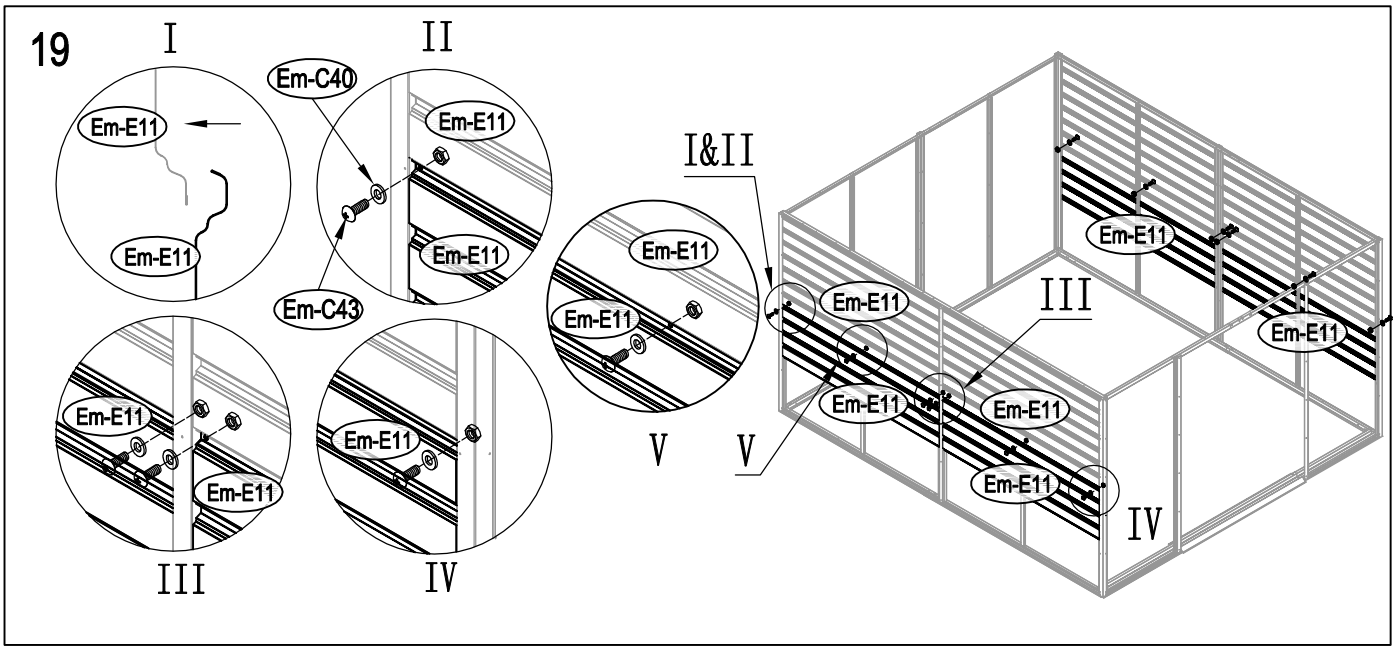

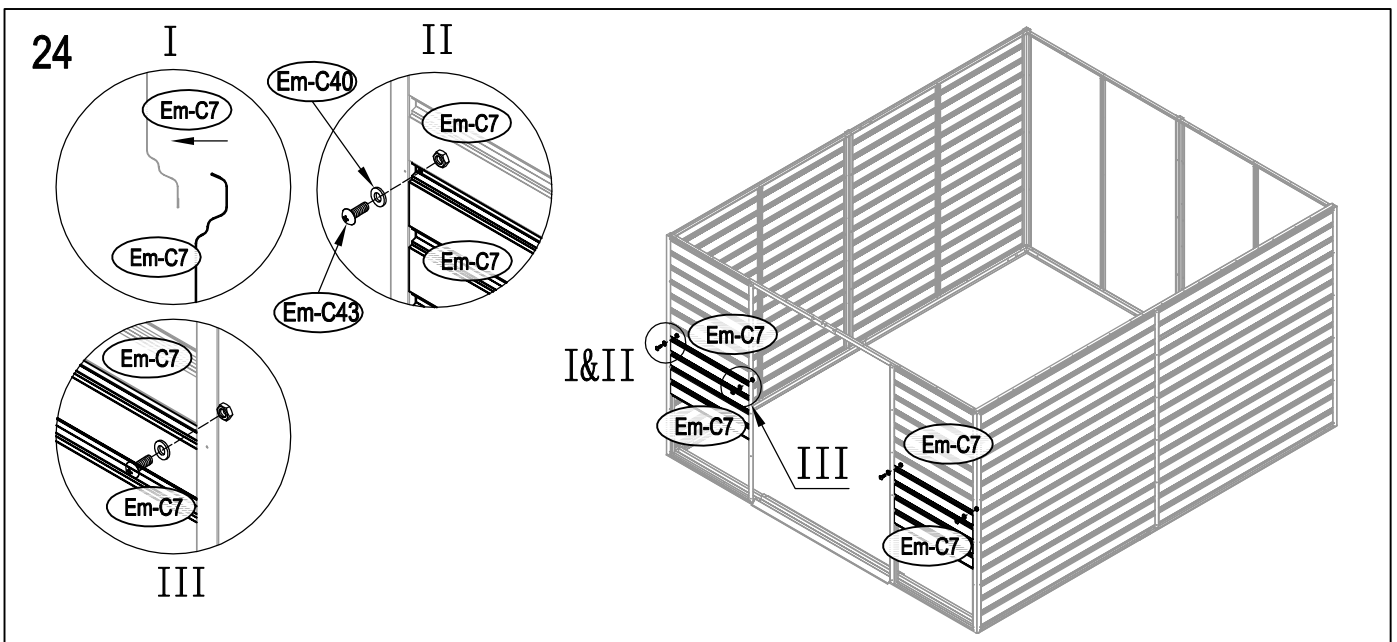
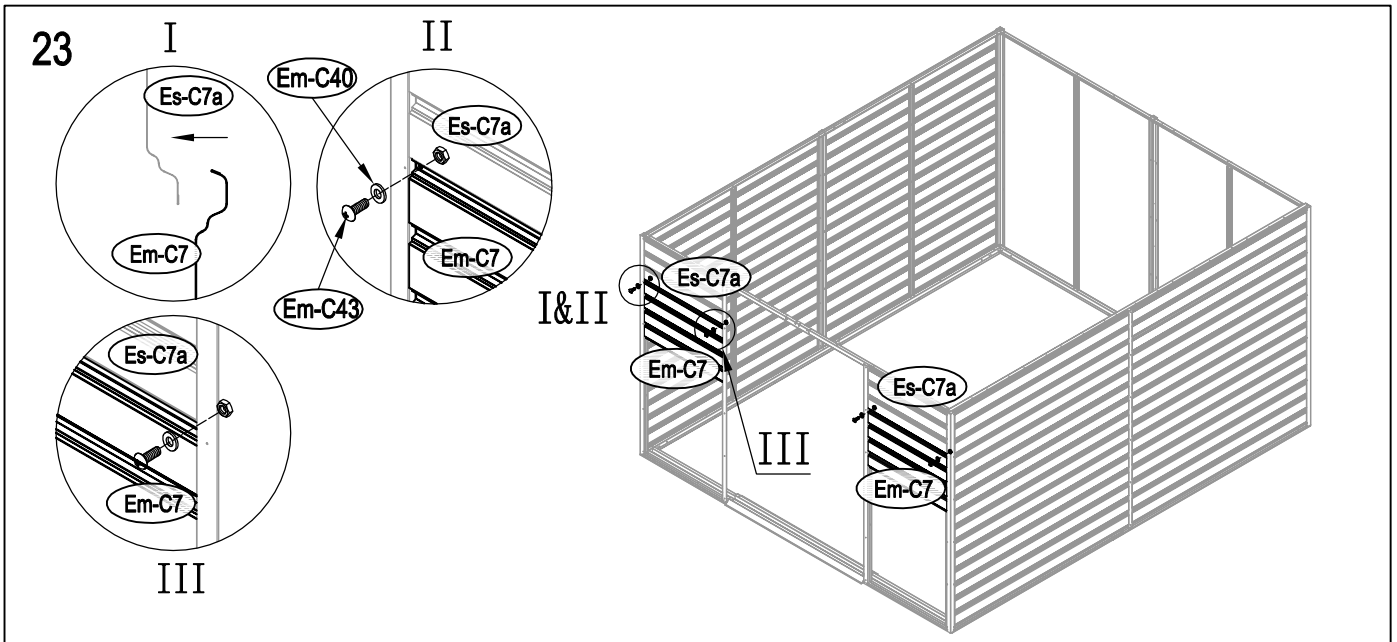
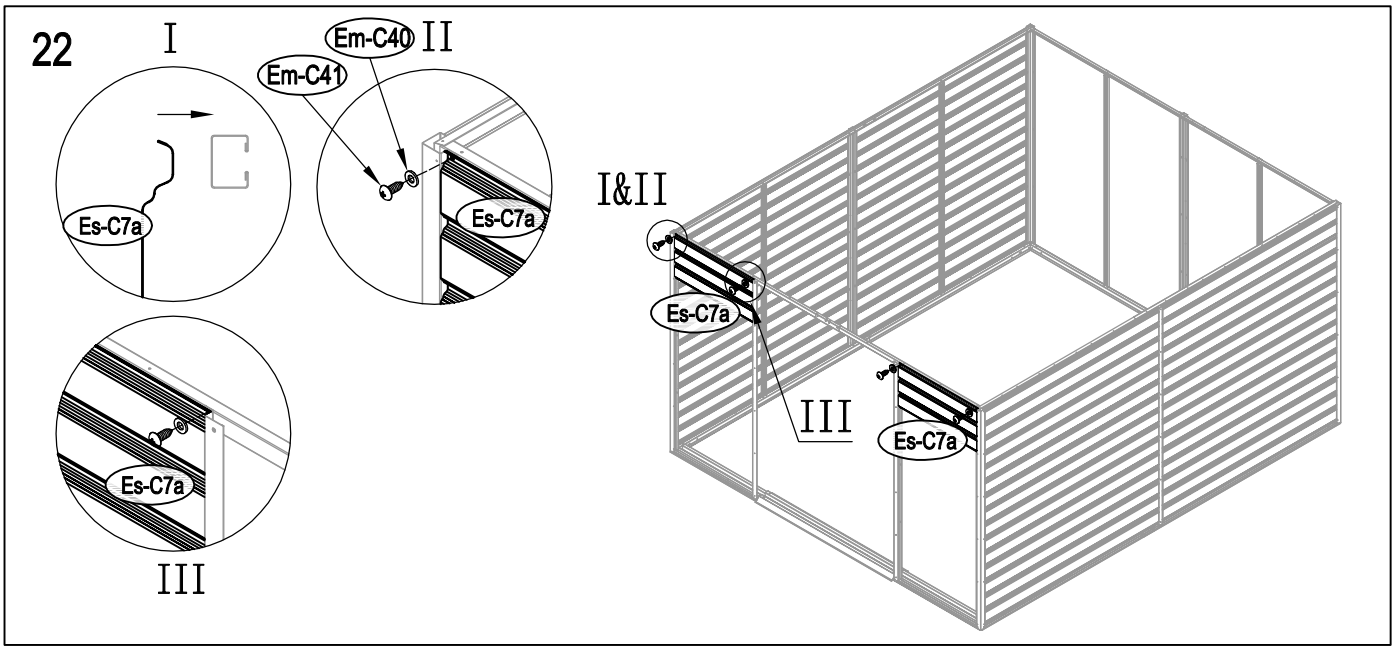

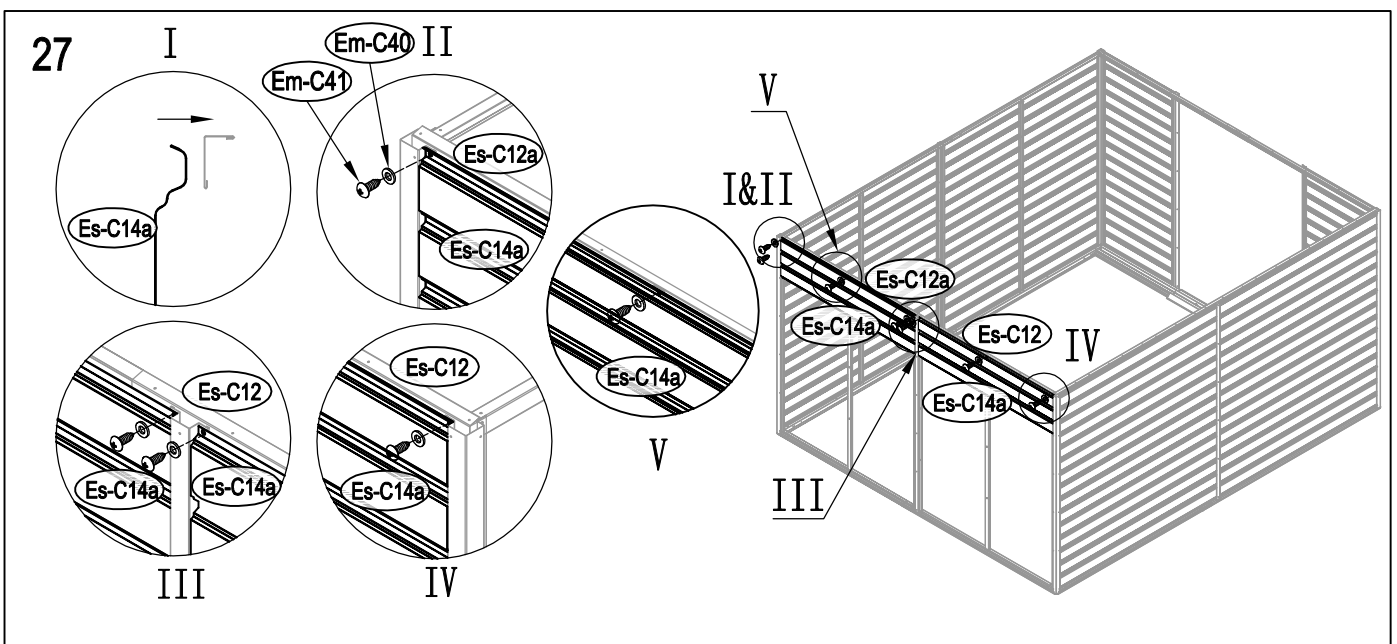
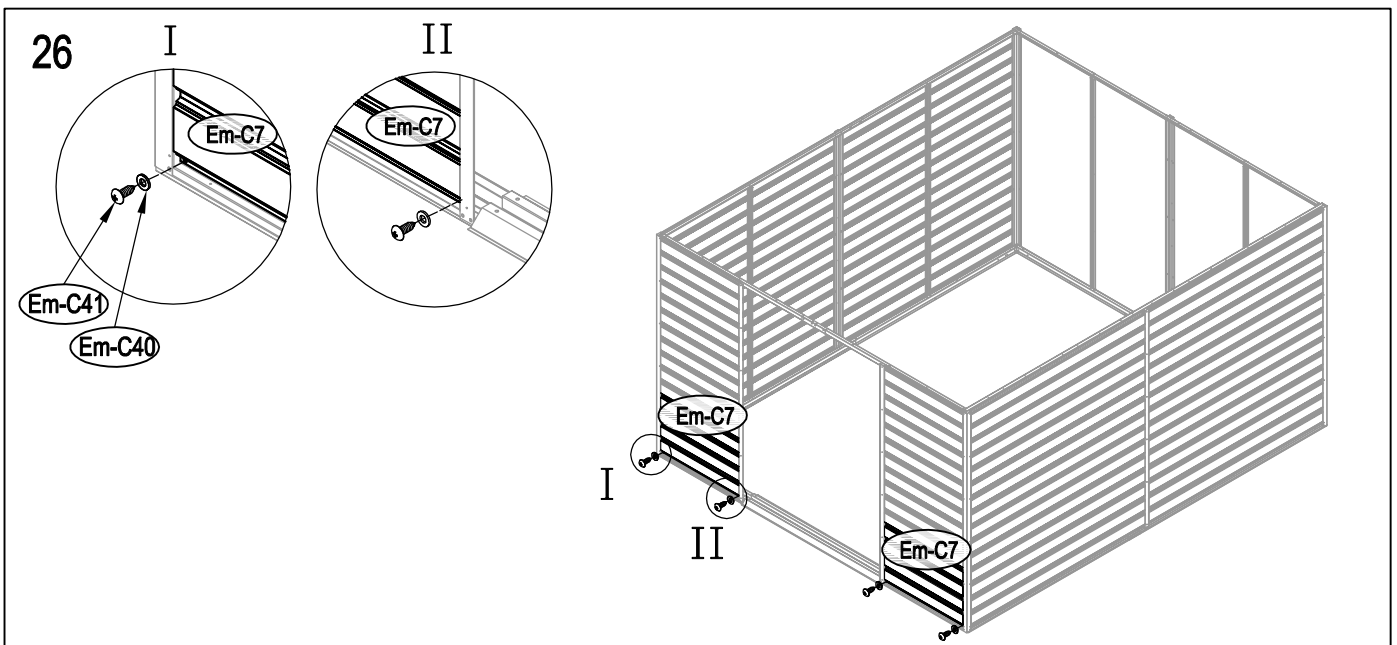
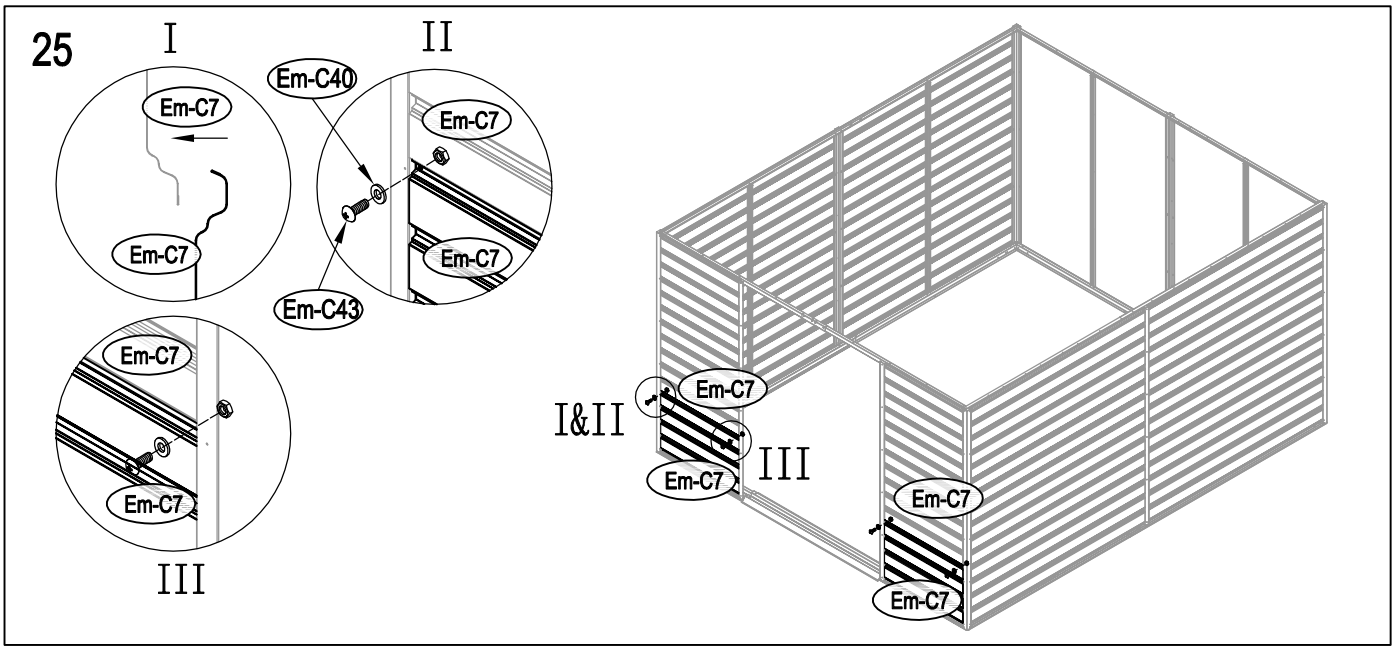

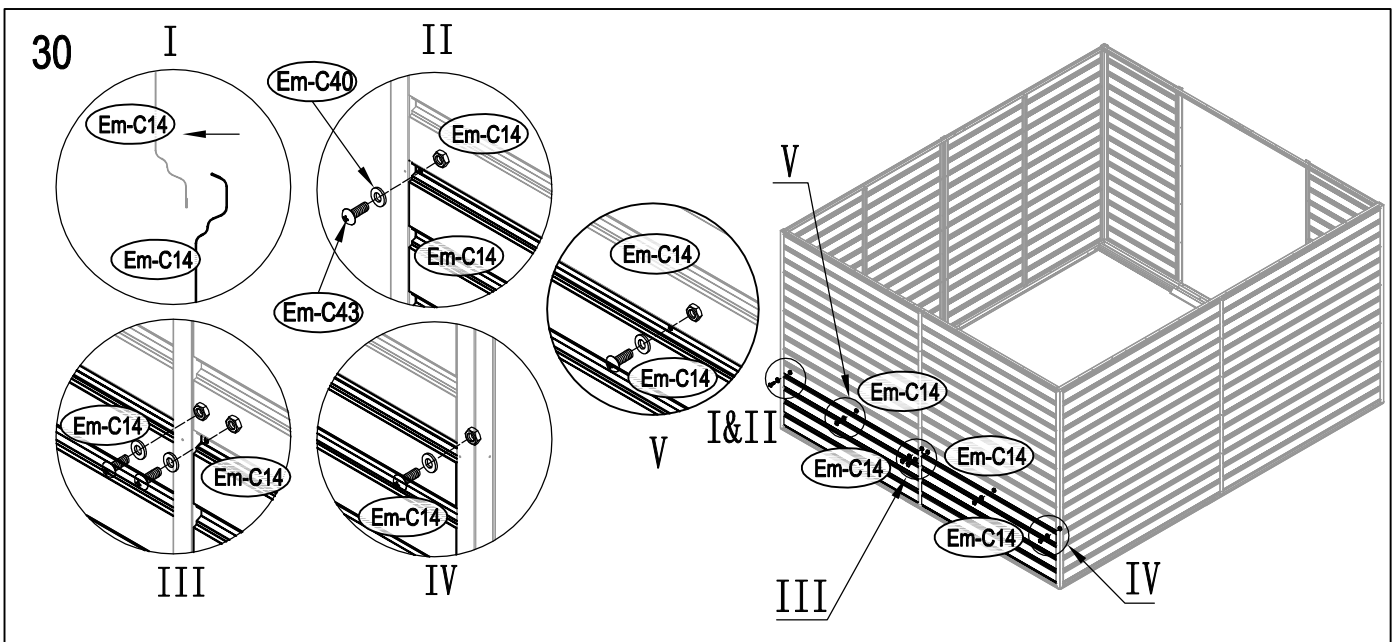
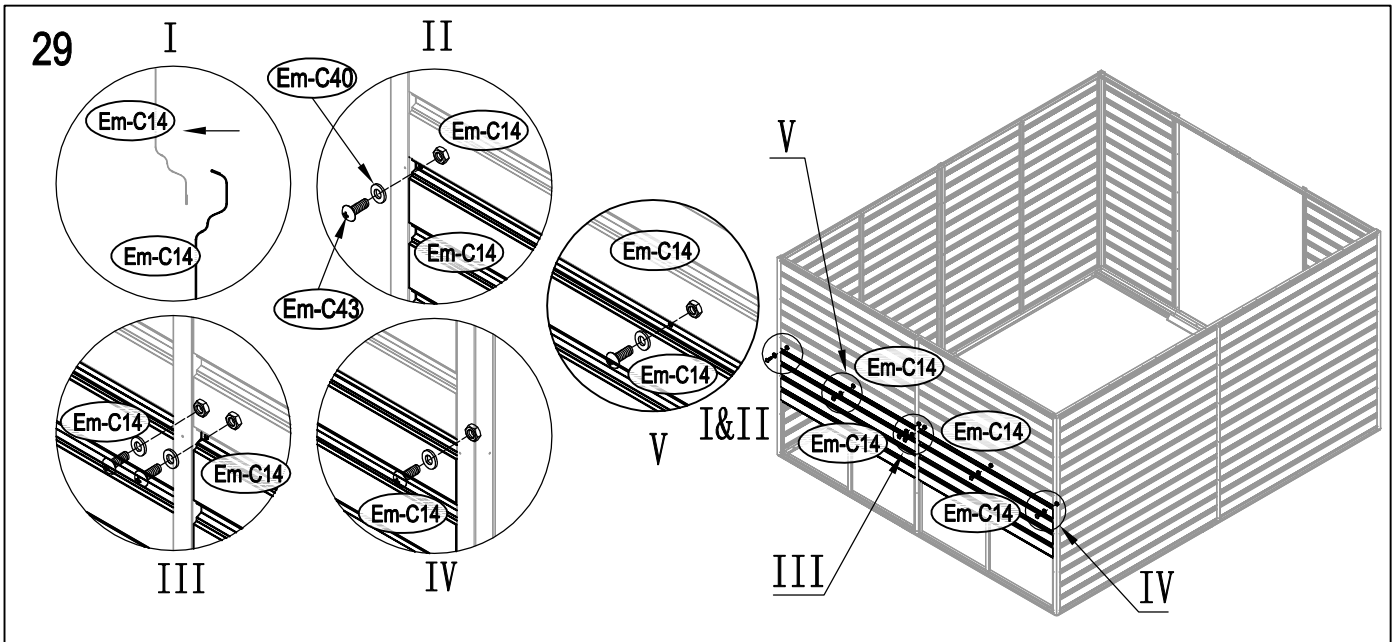
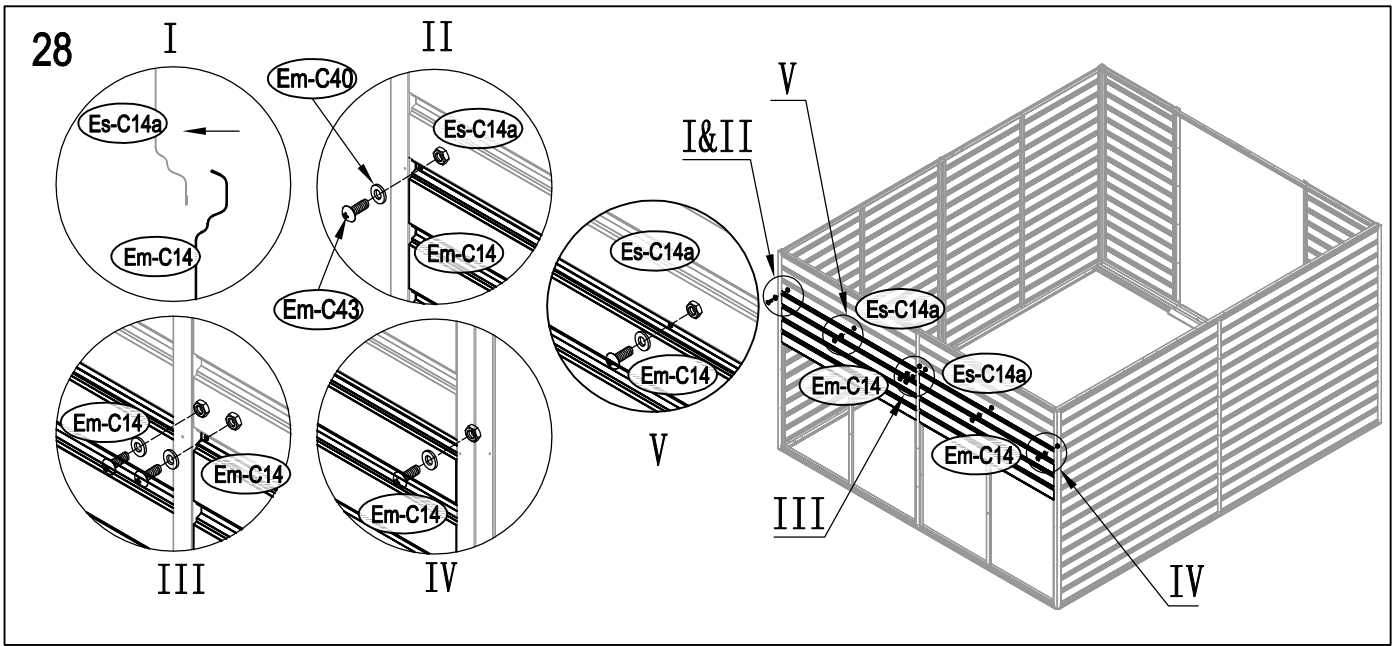

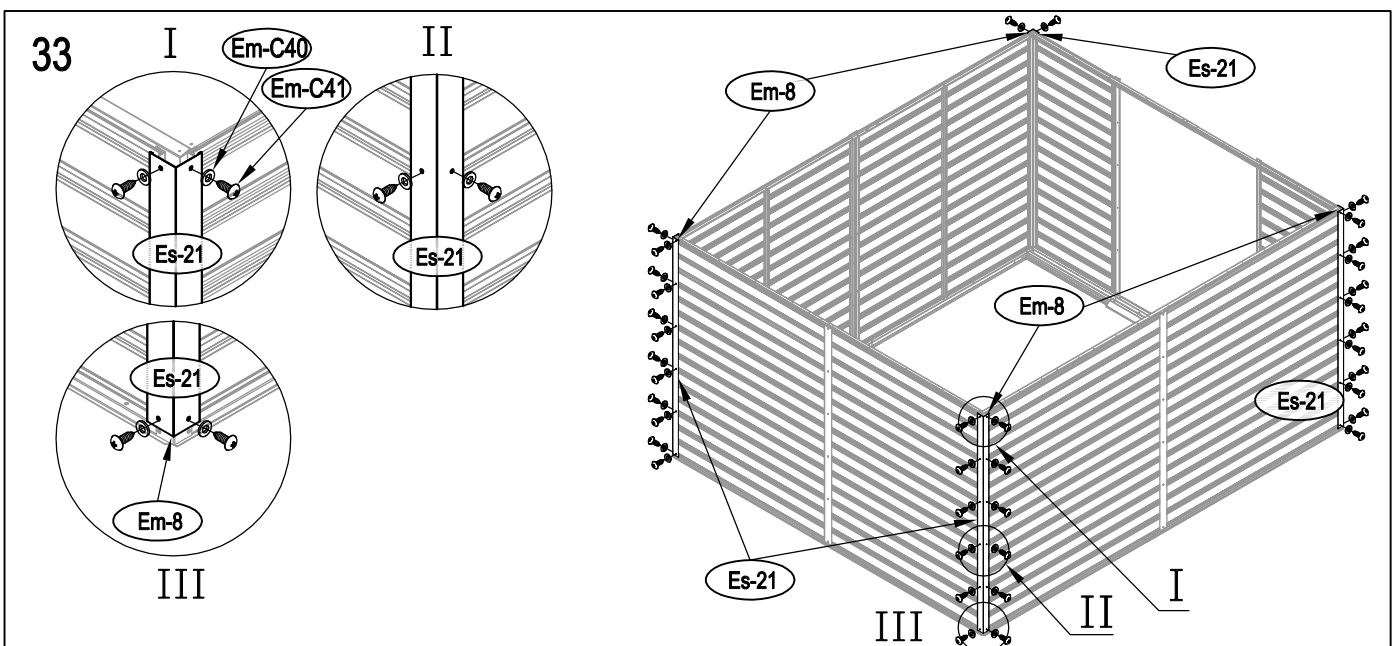
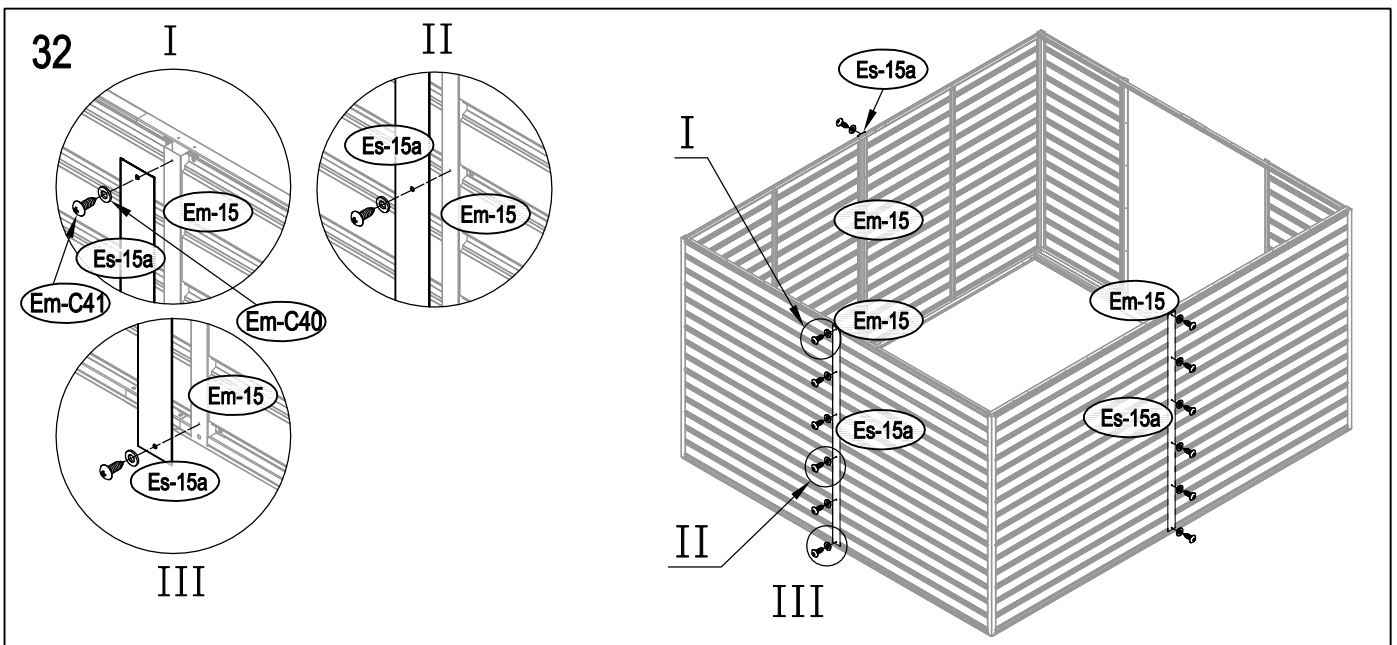
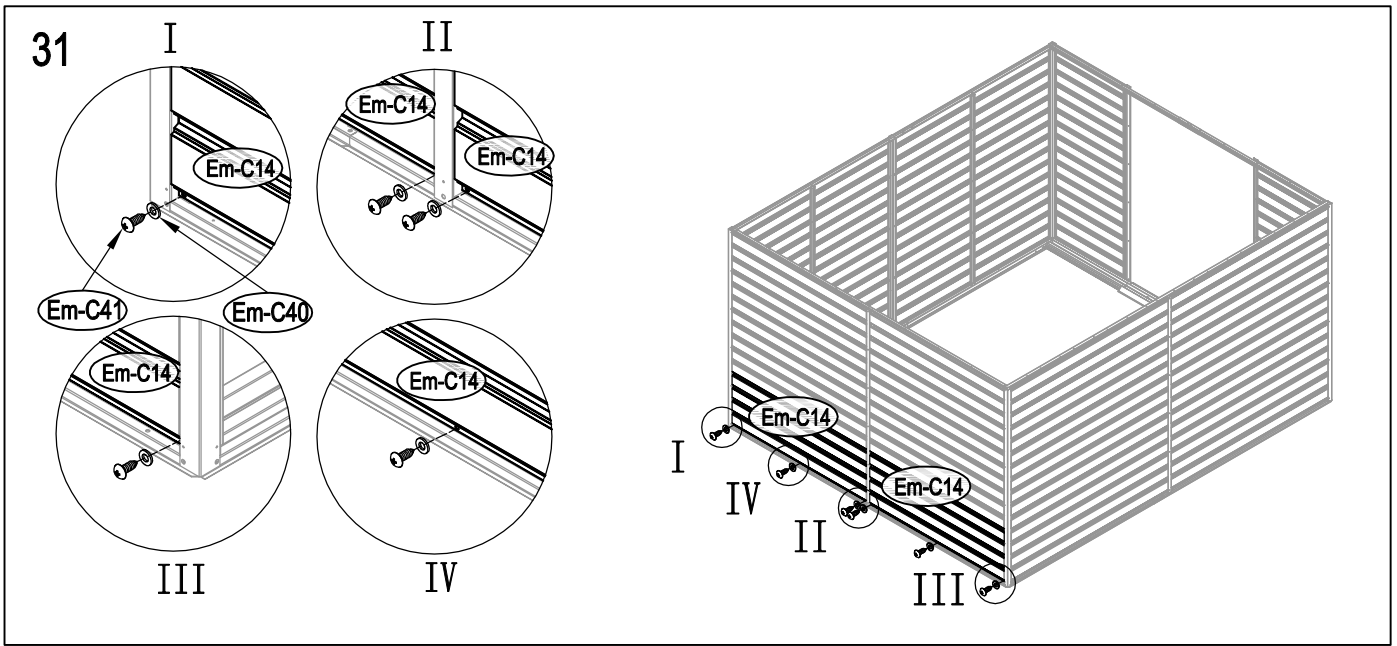

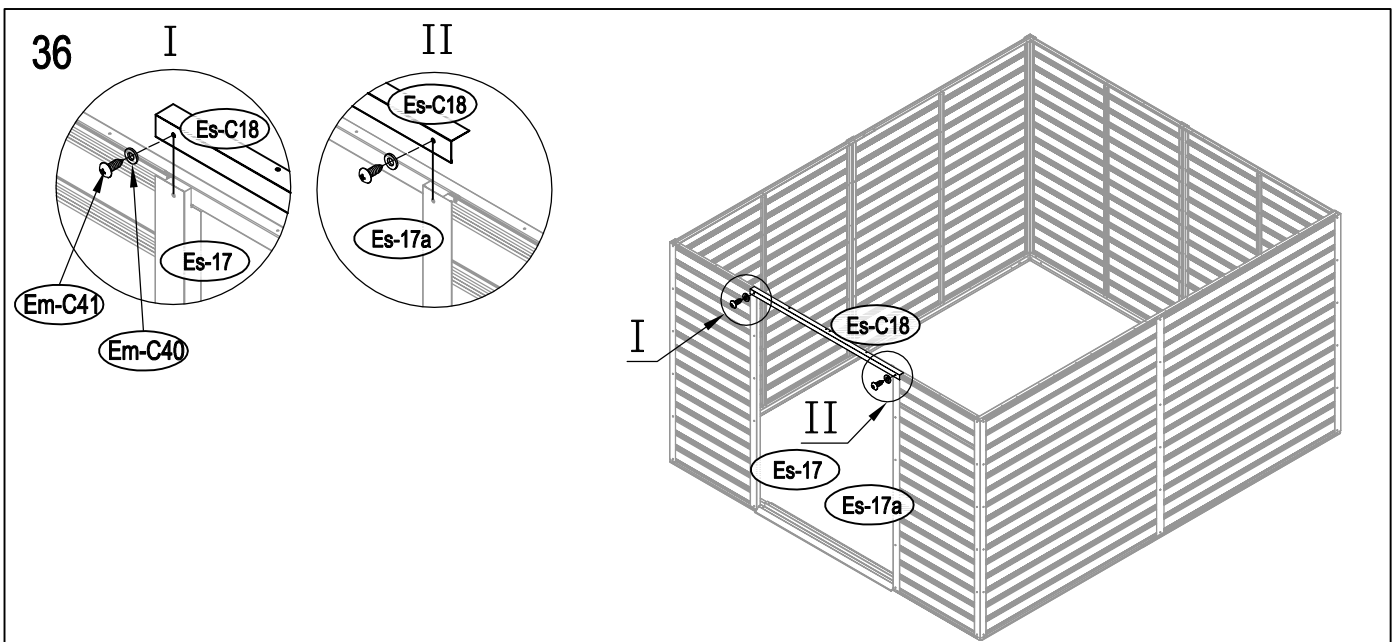
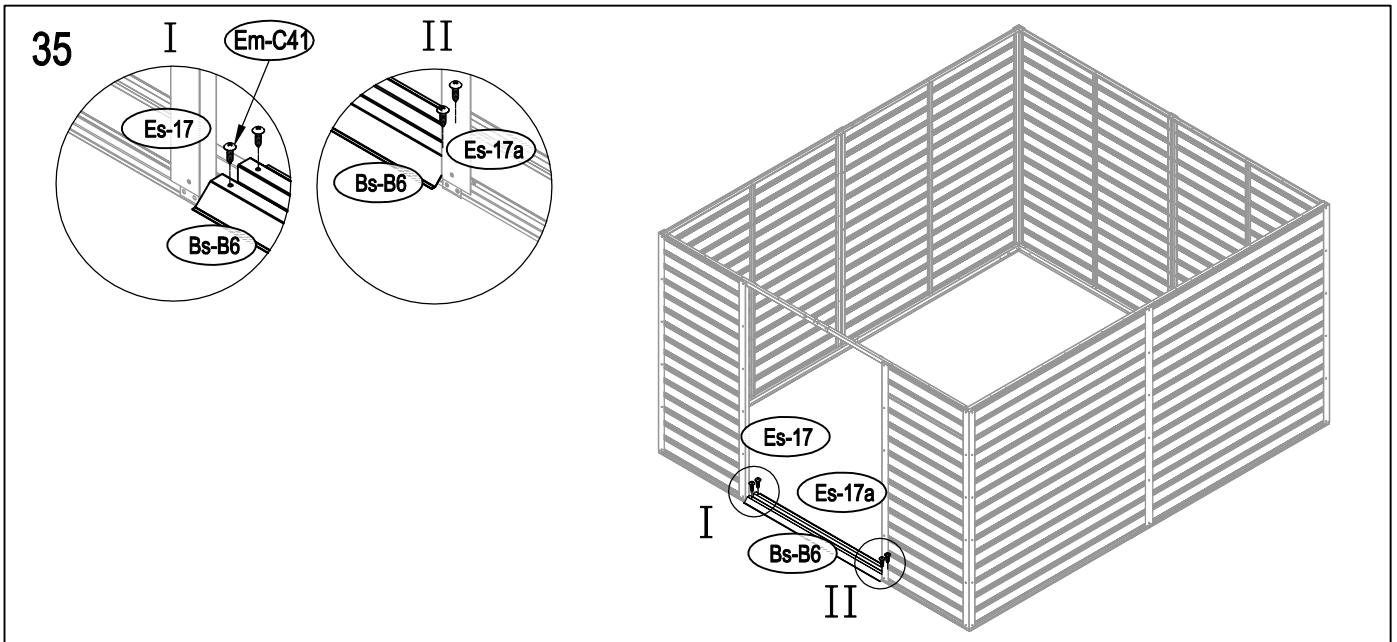
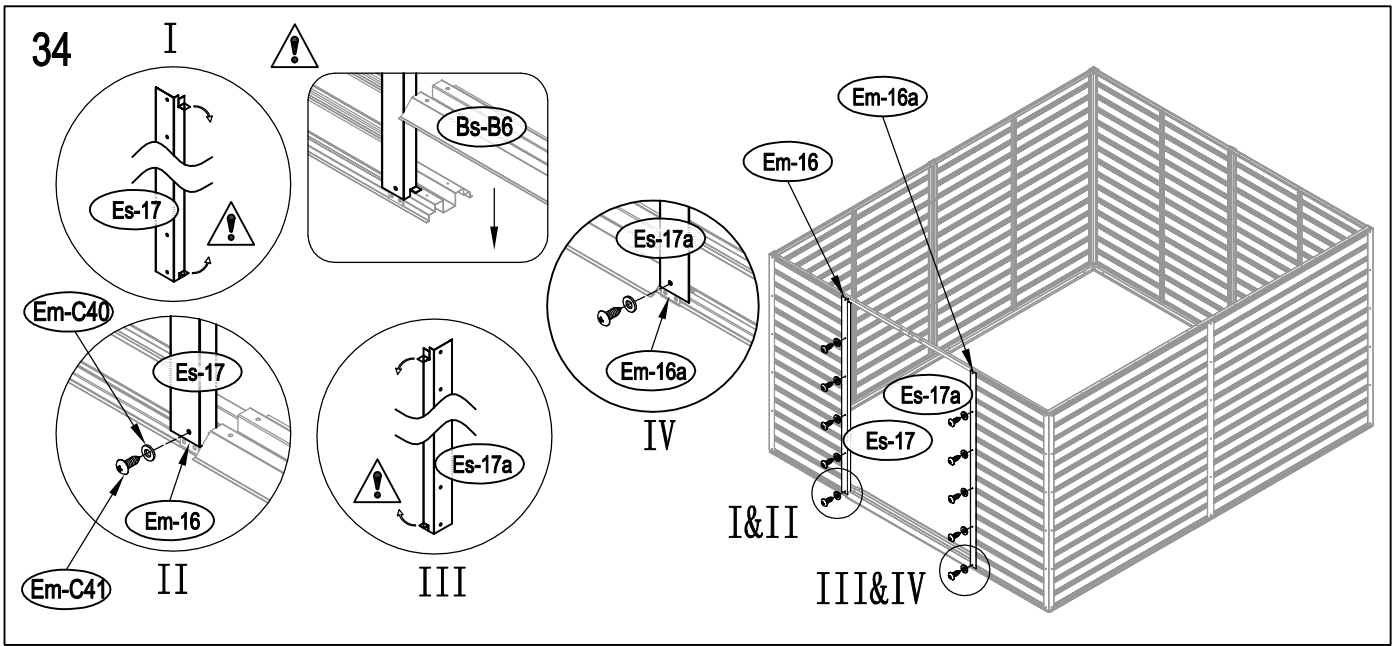

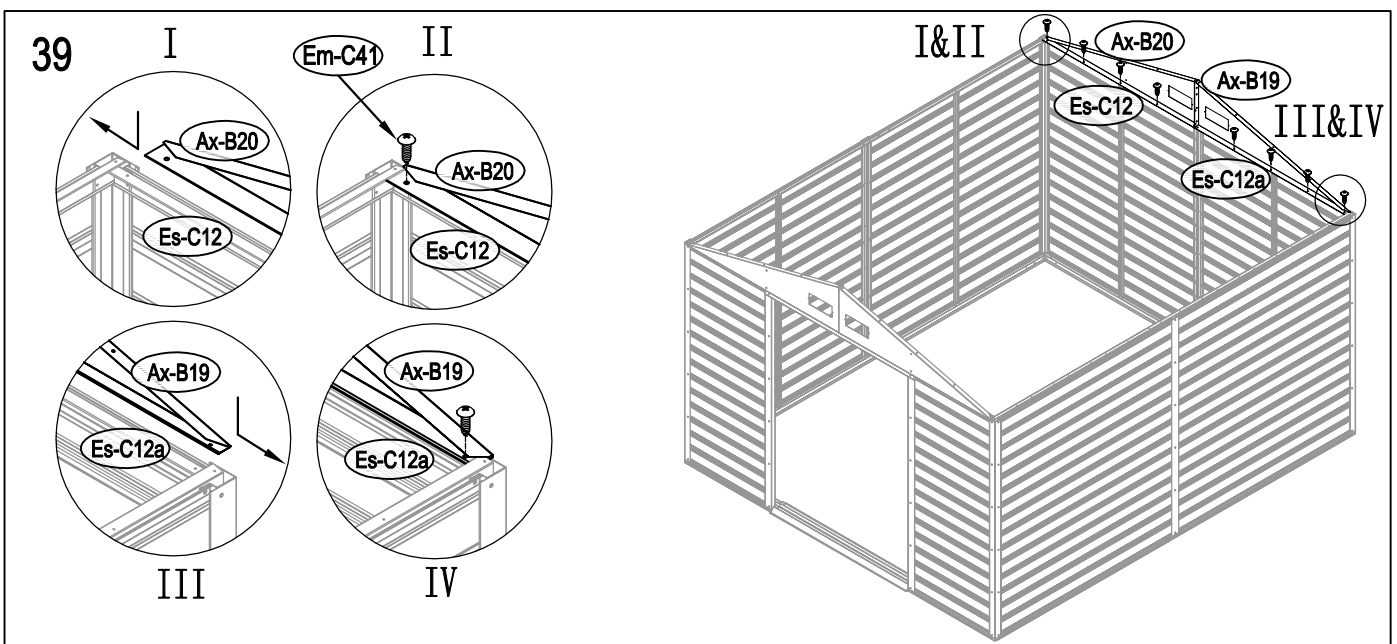
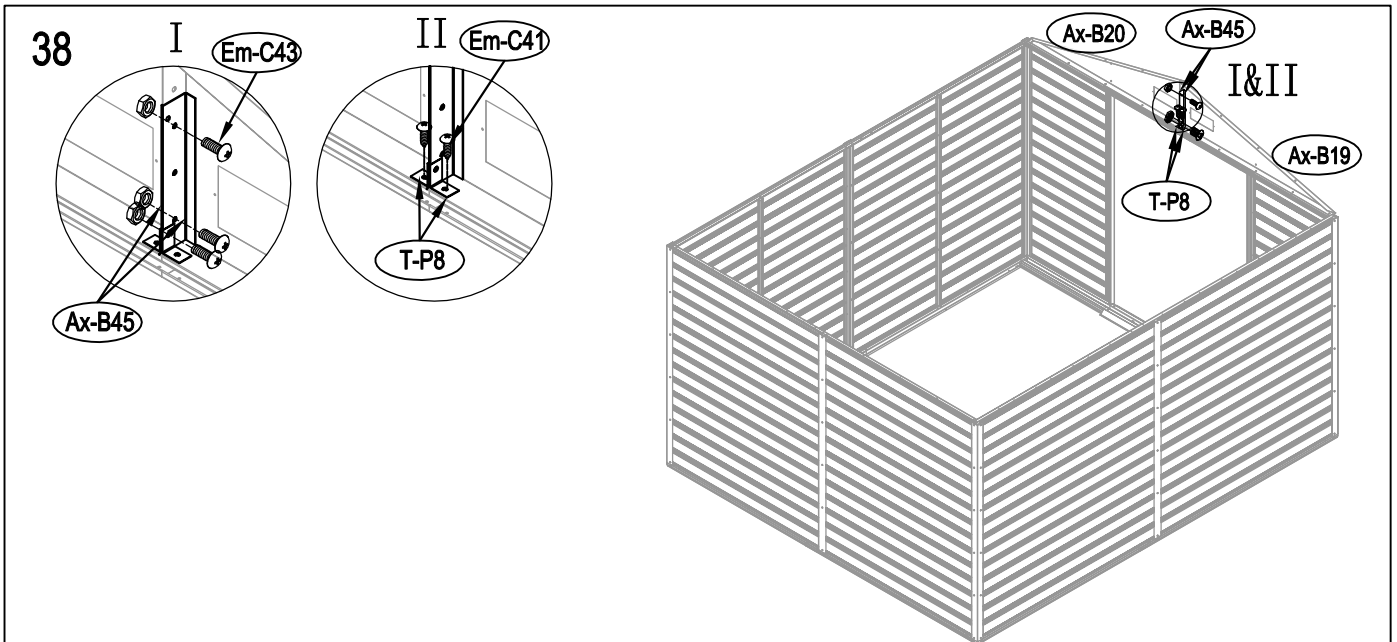
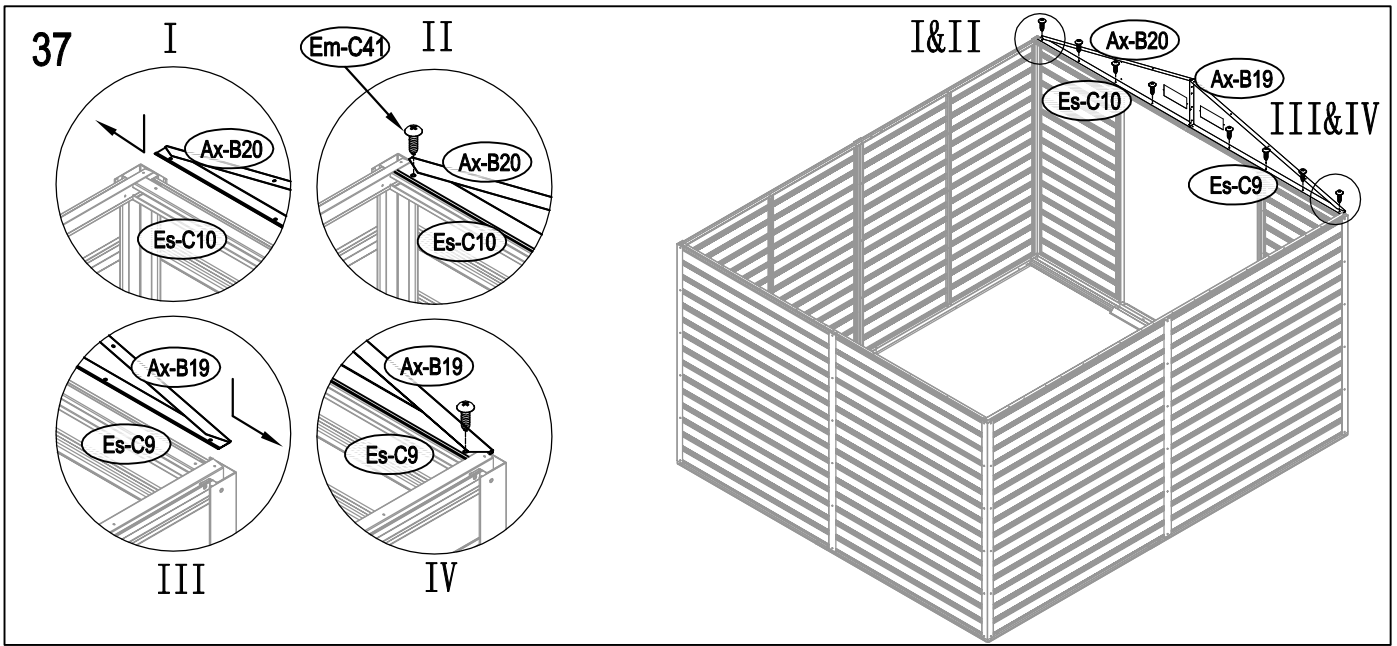

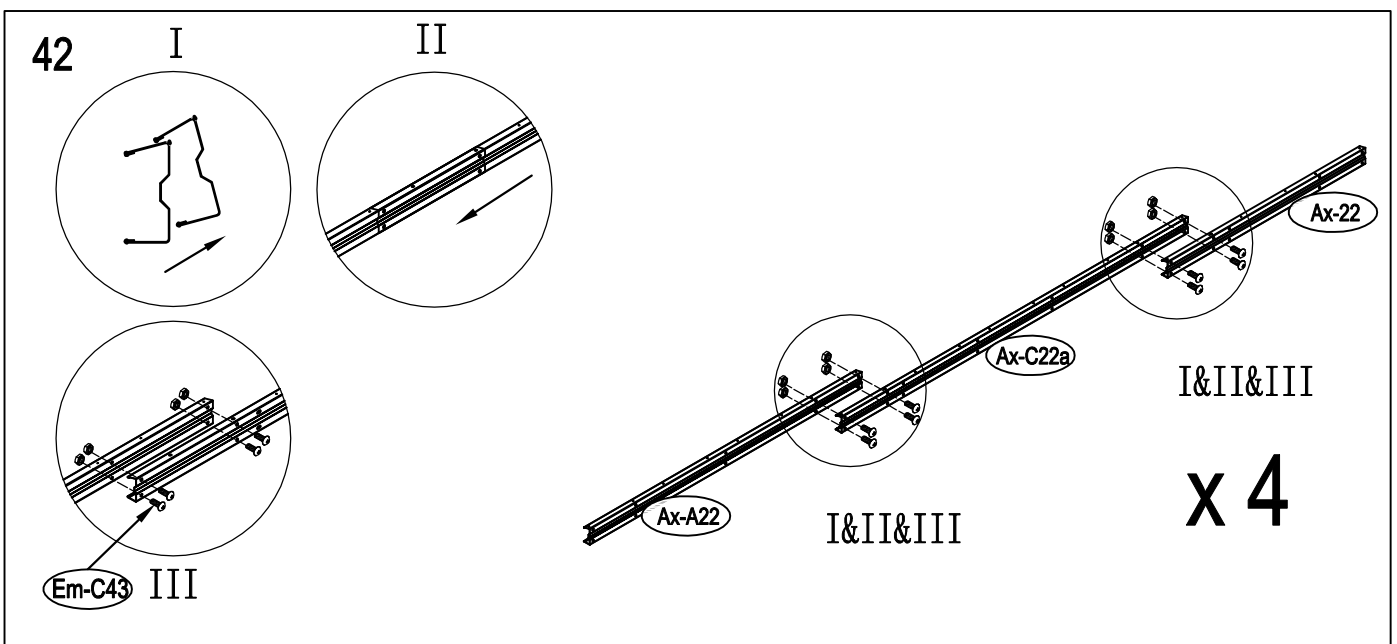
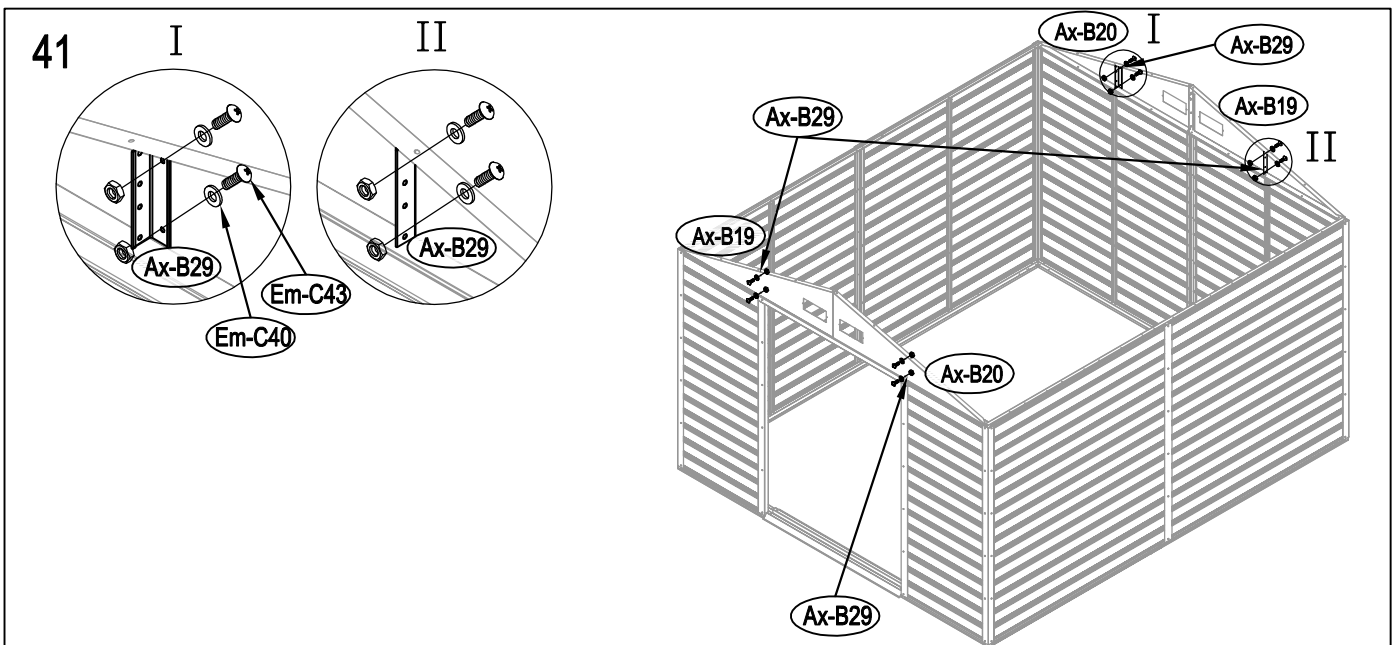
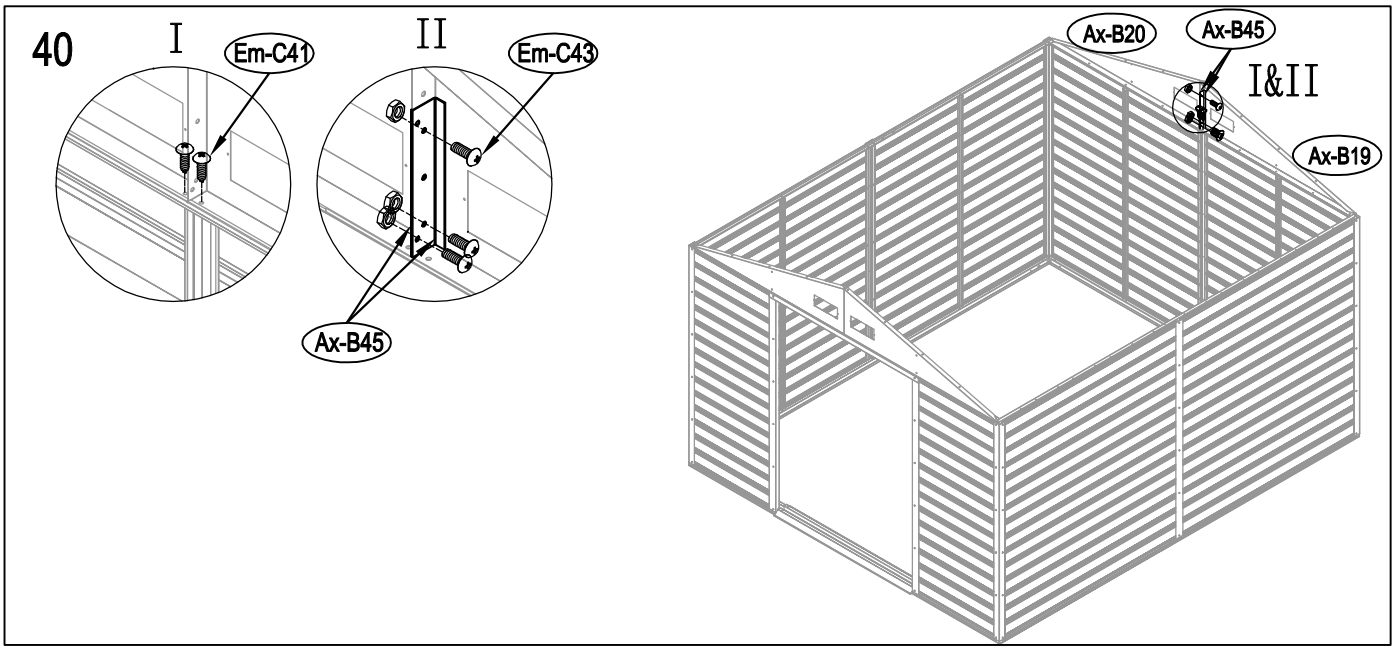

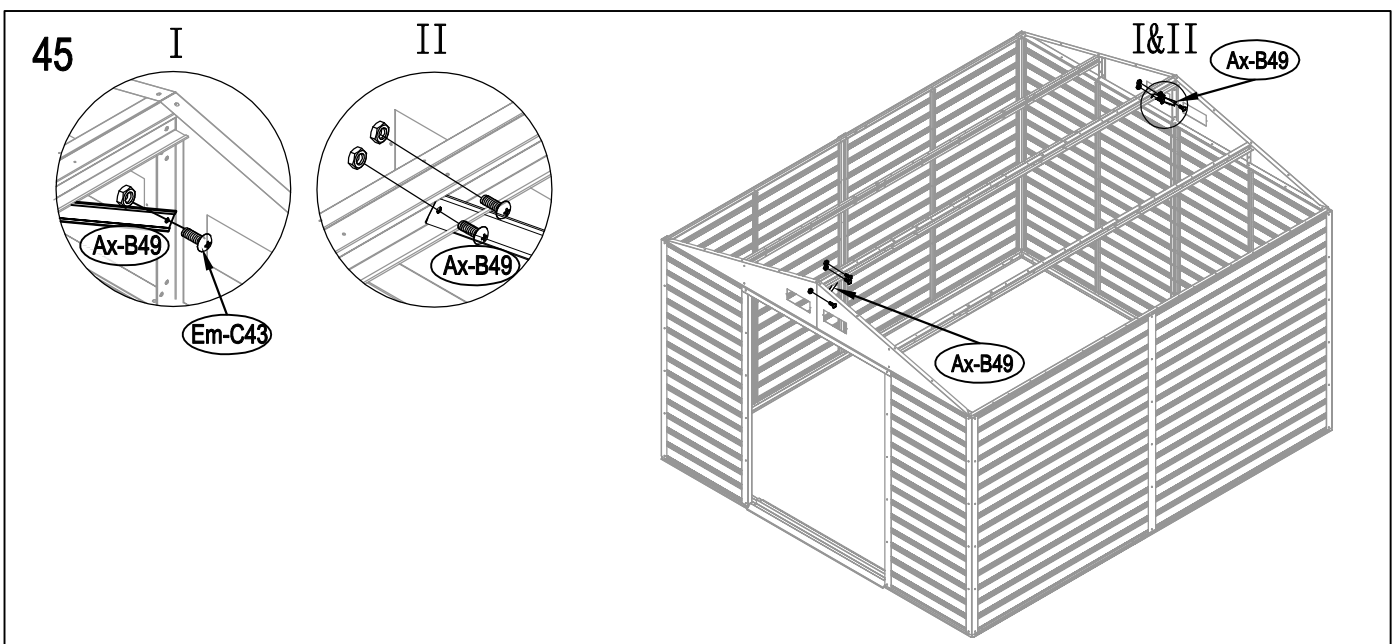
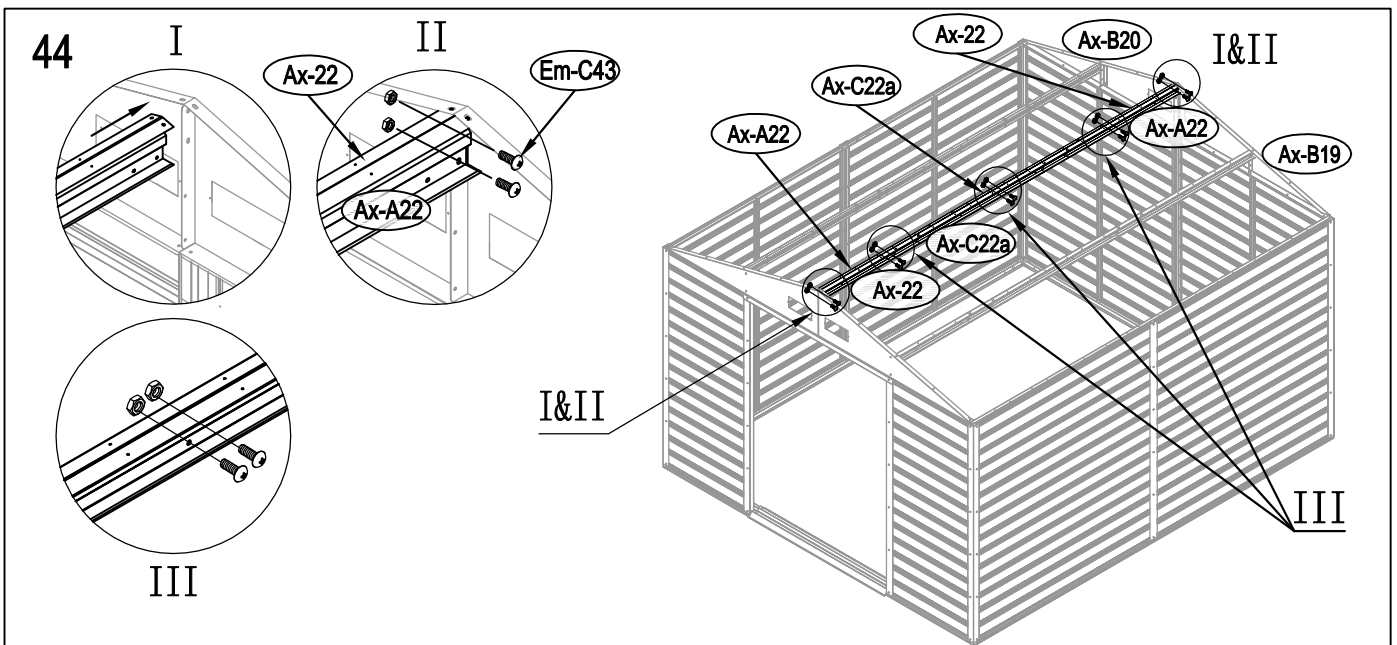
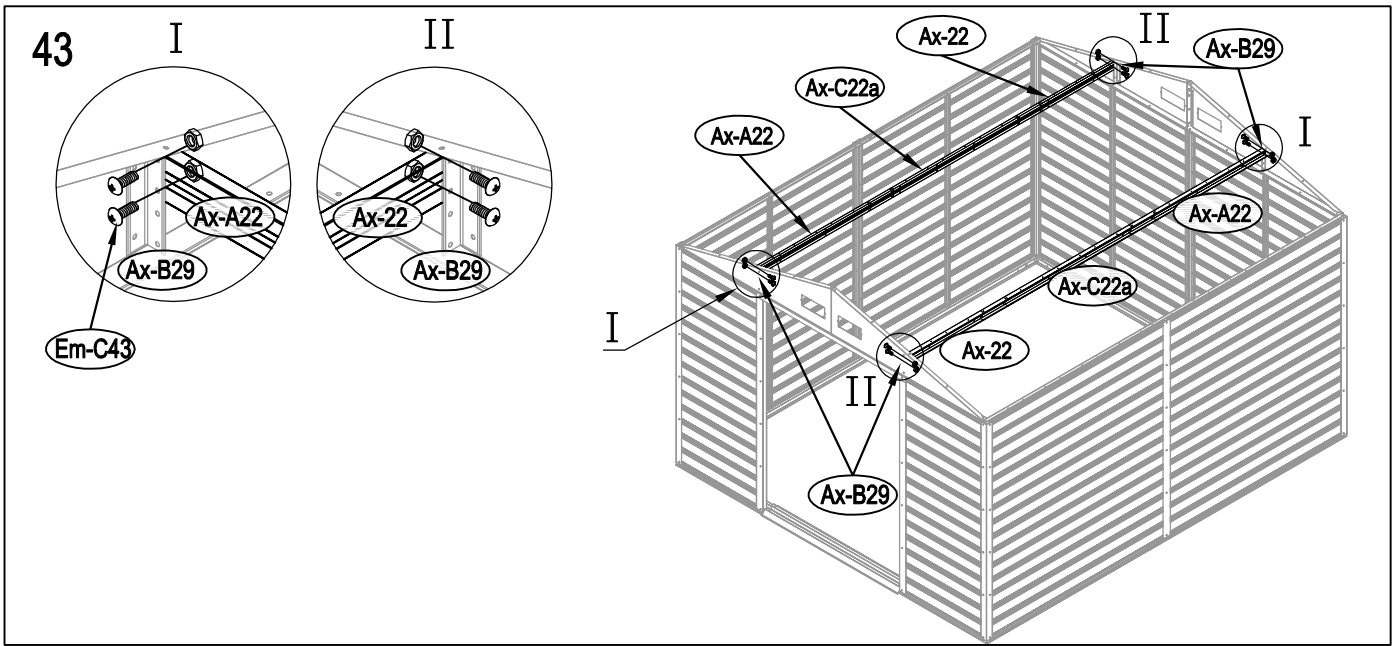

46

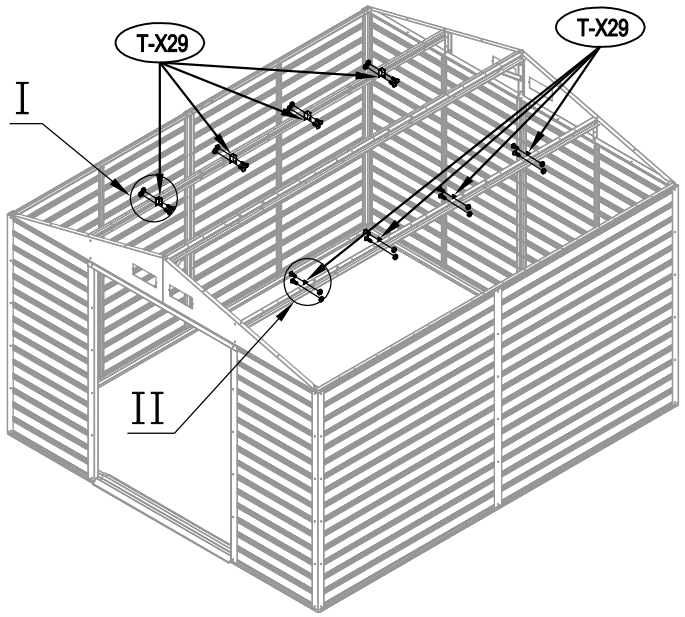
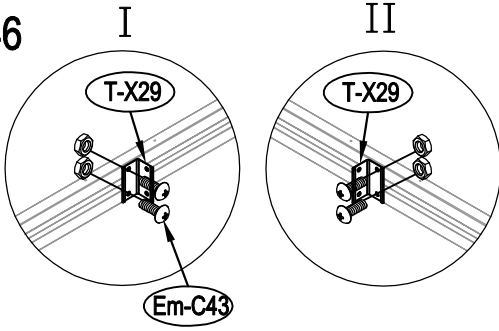

47

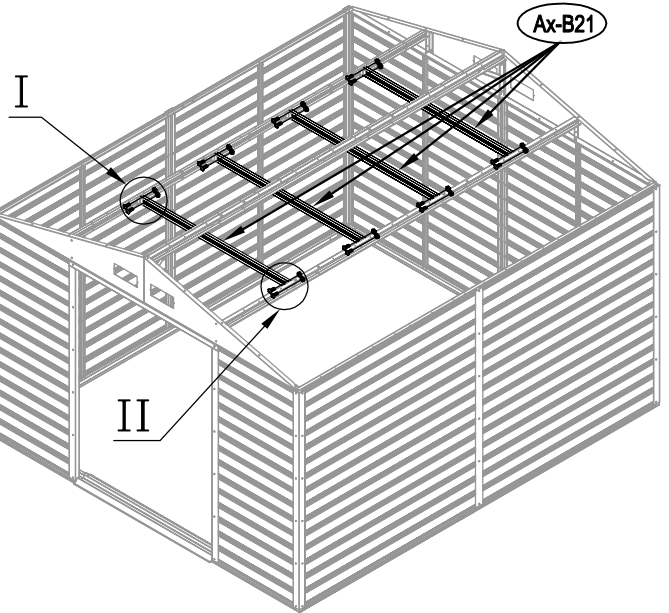
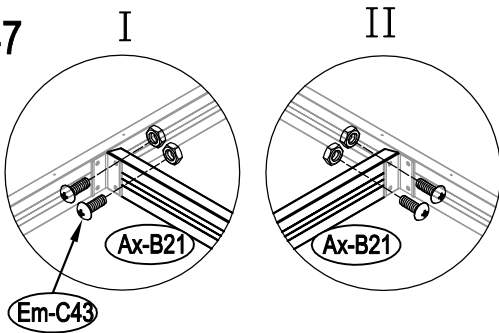

48

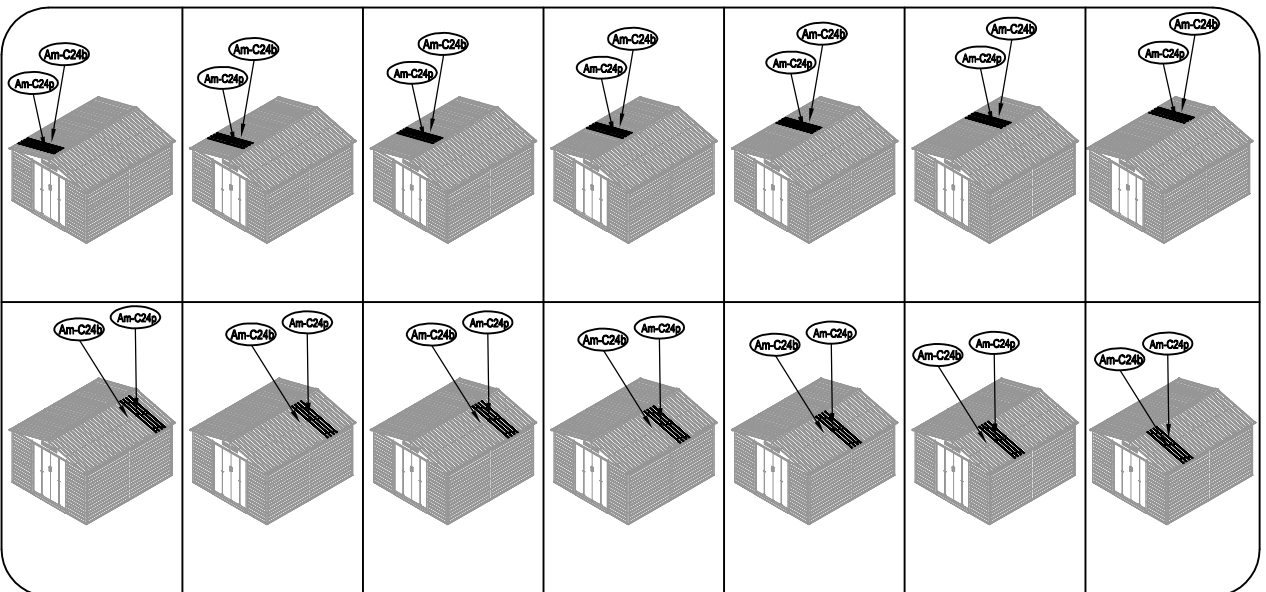

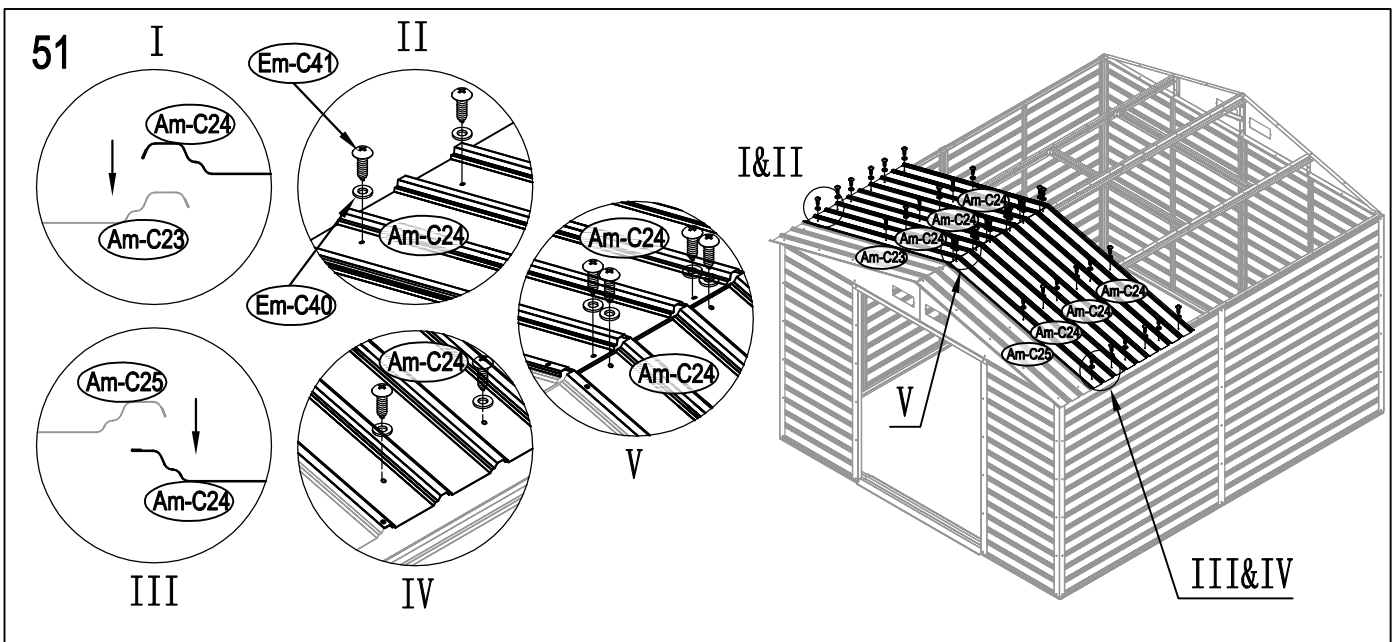
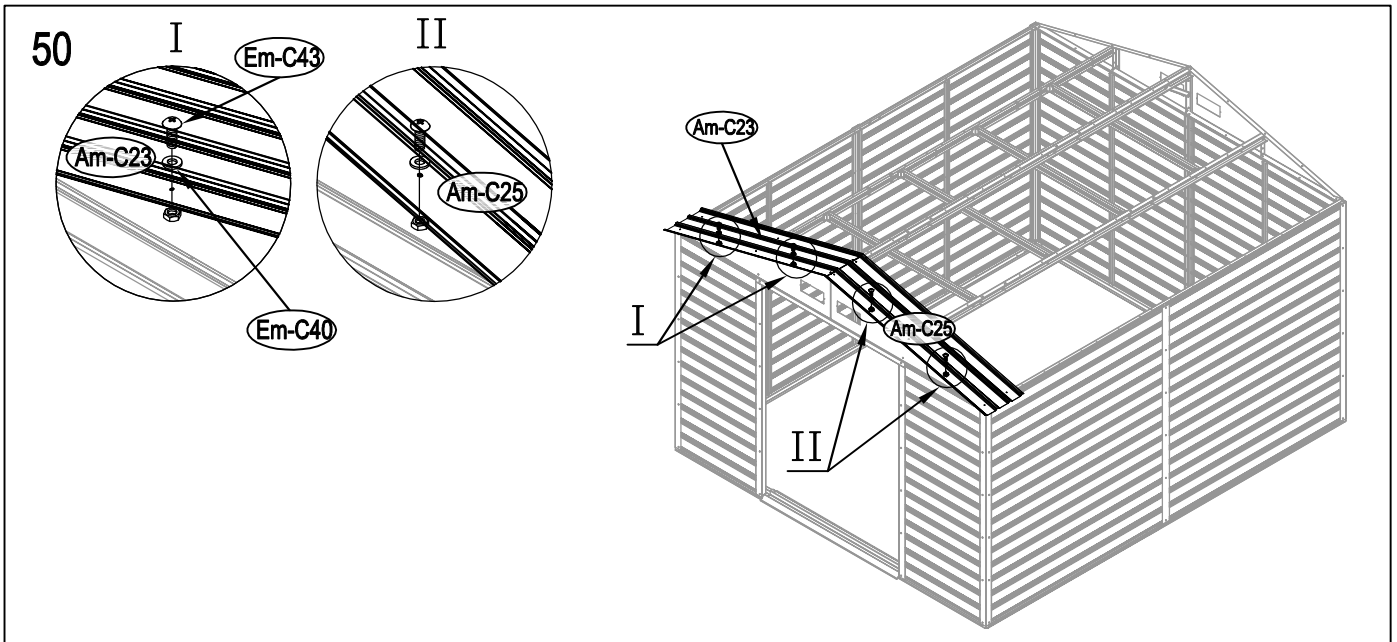
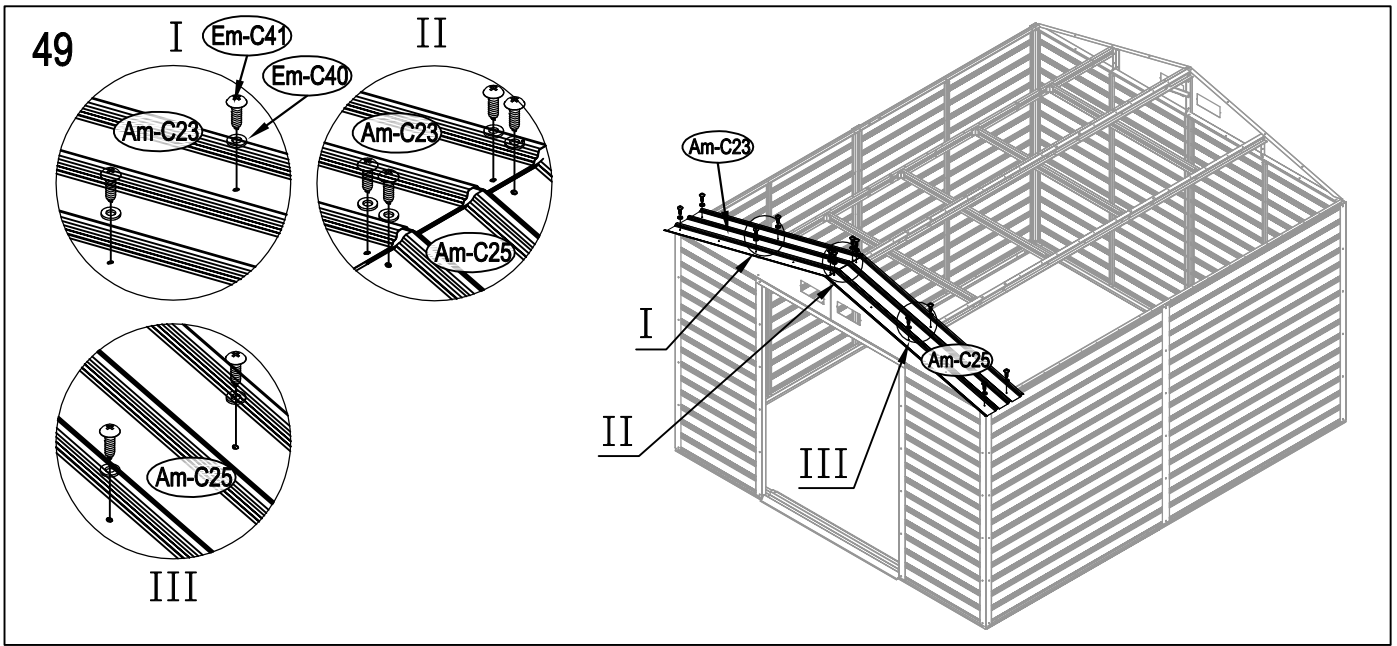

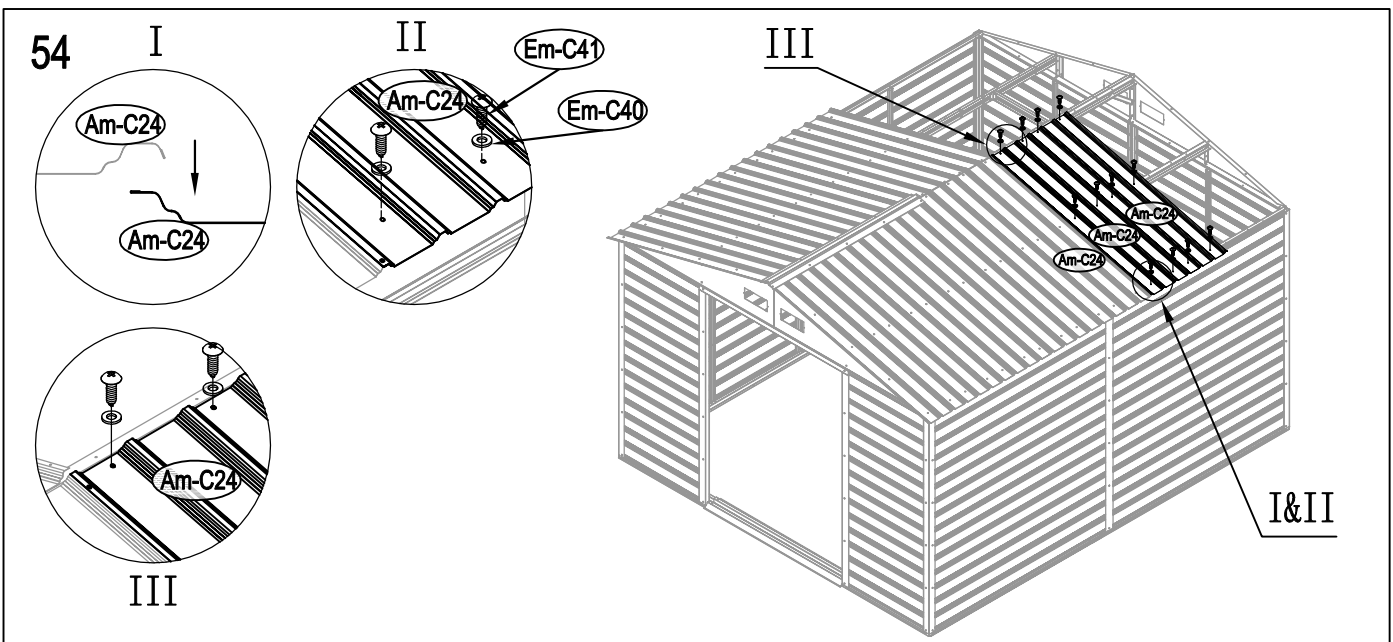
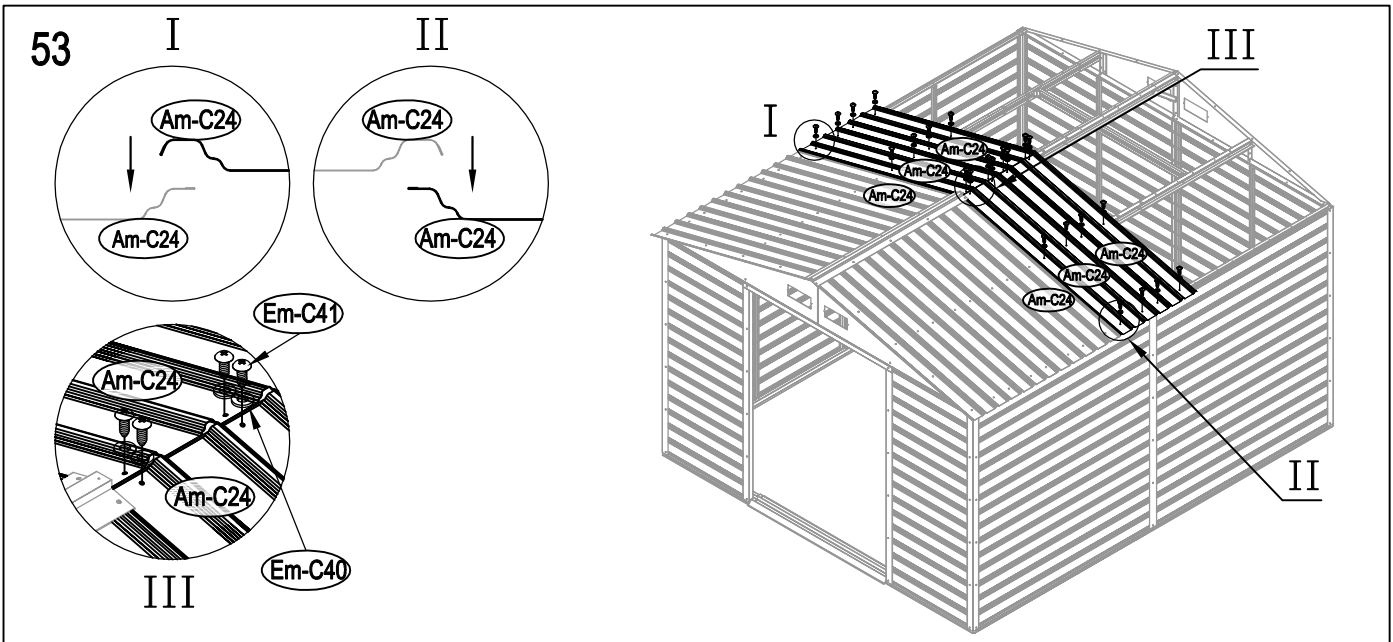
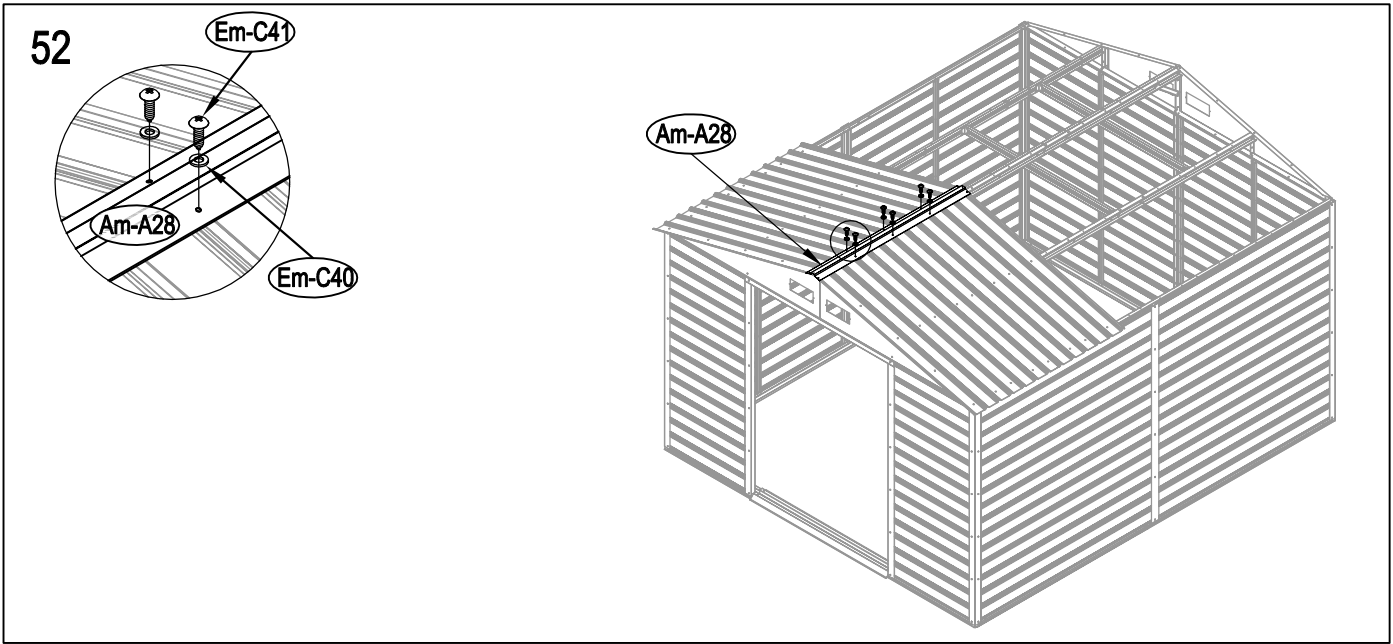

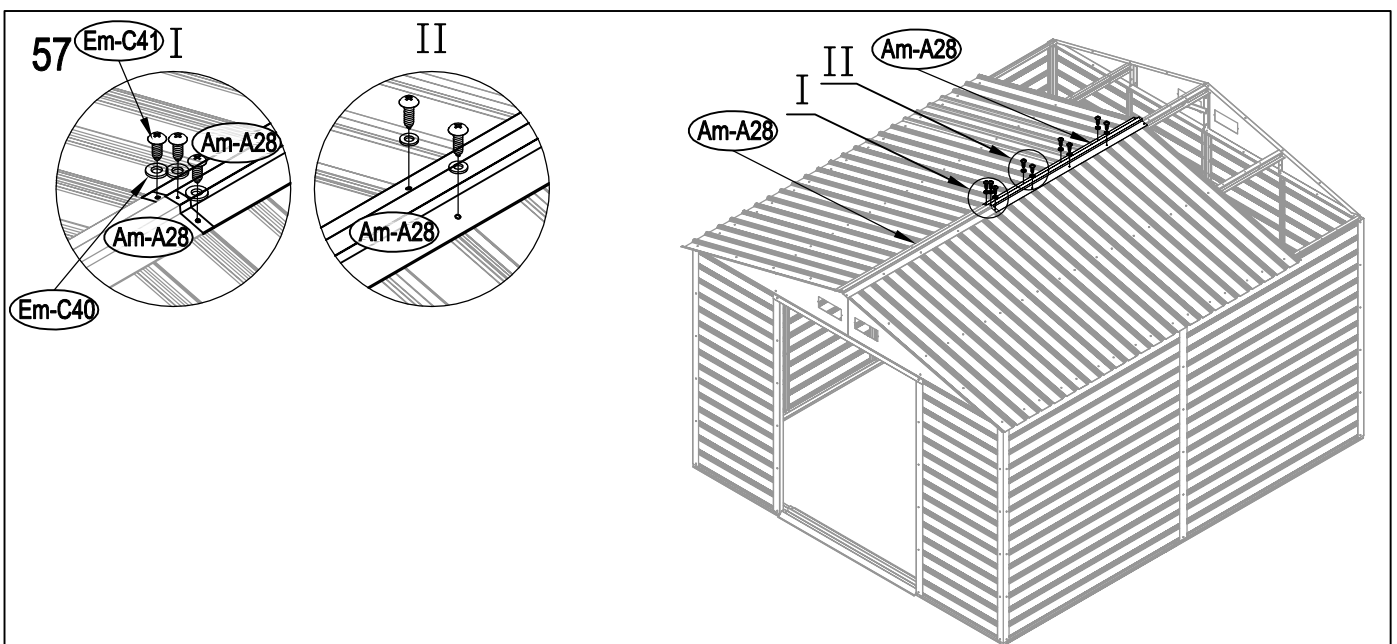
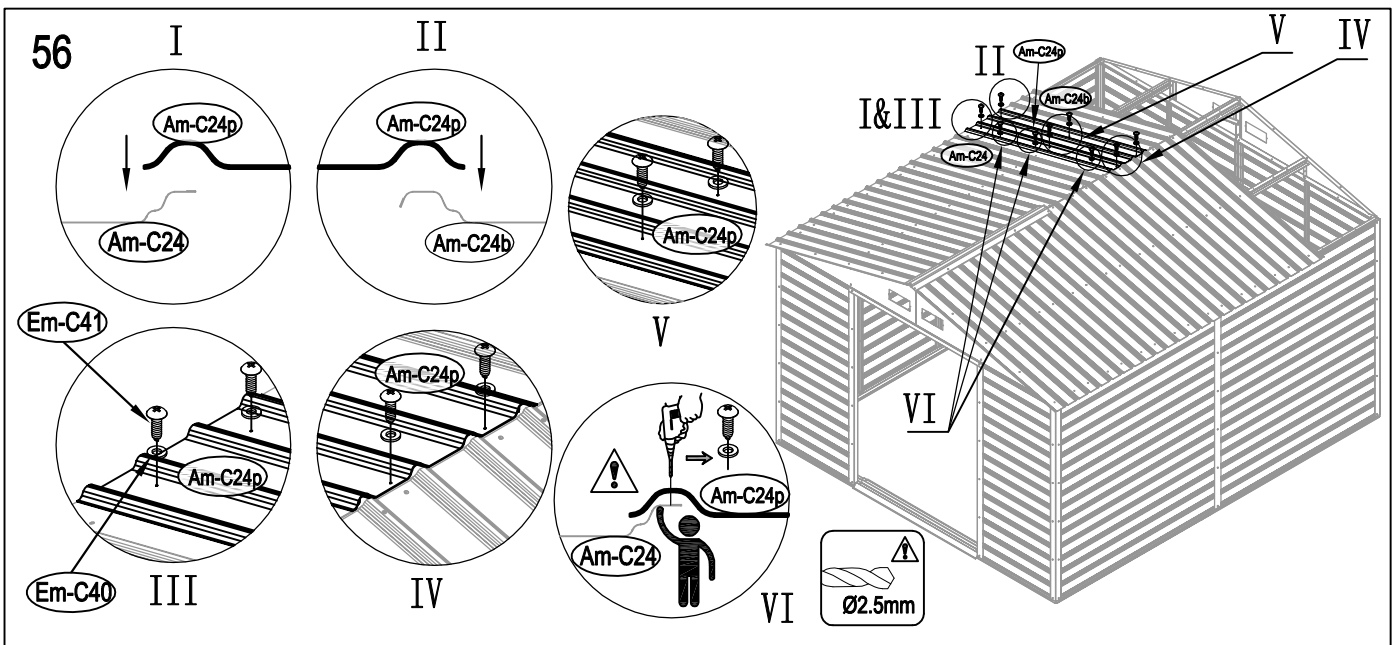
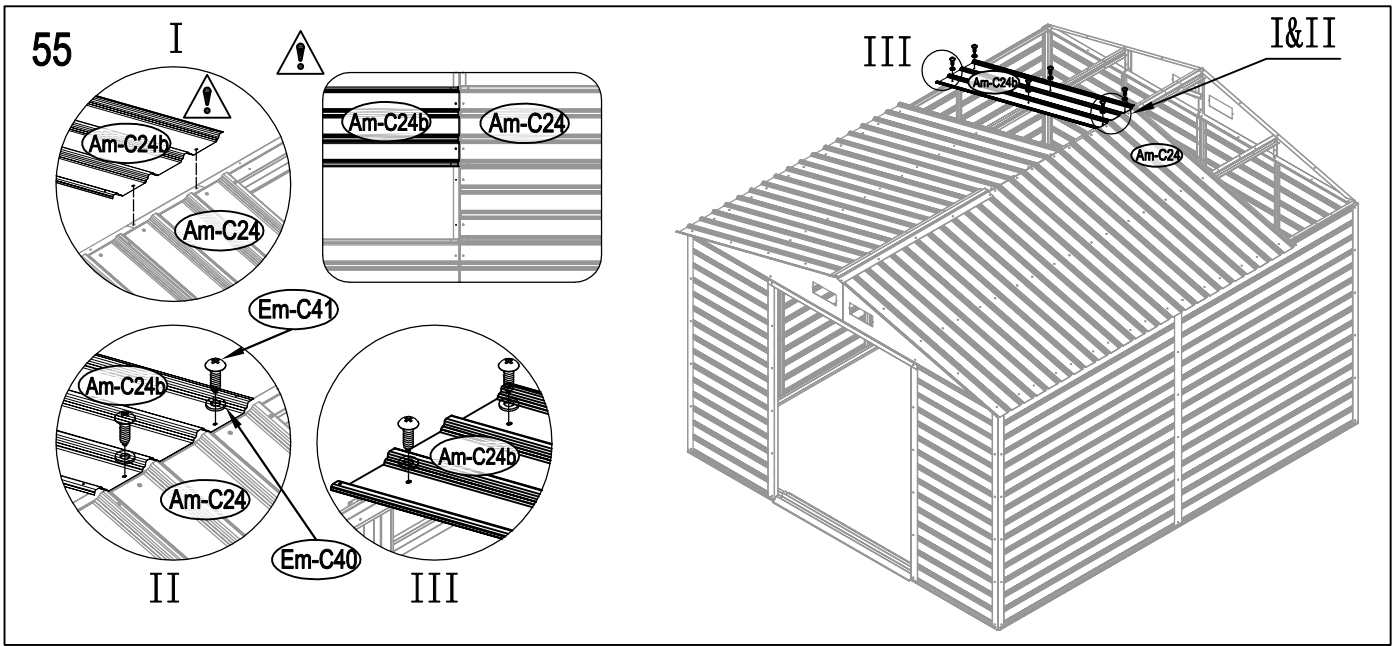

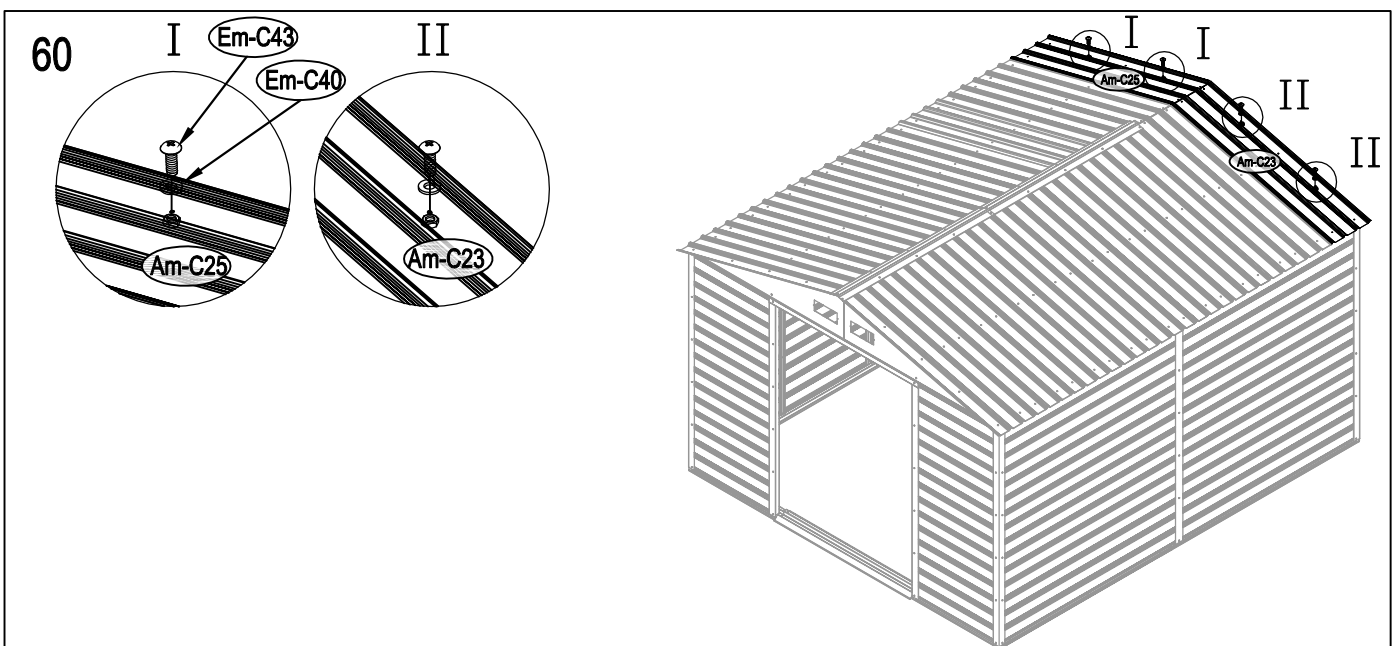
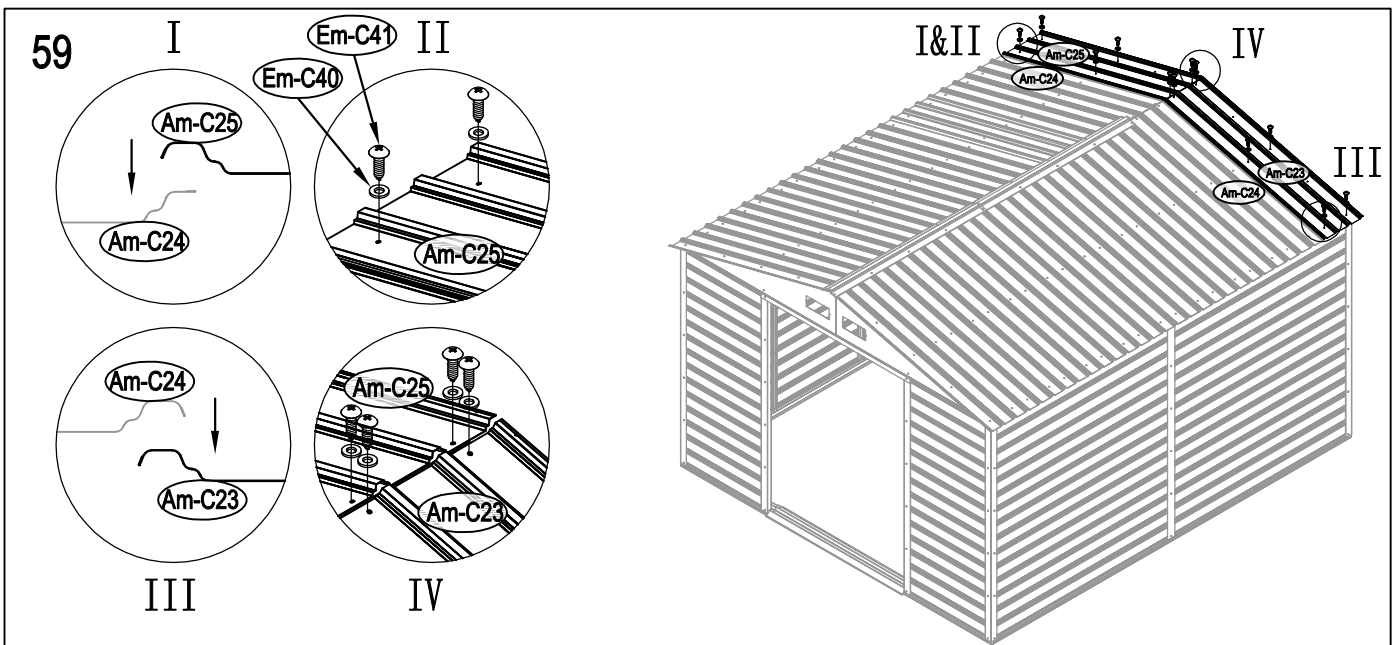
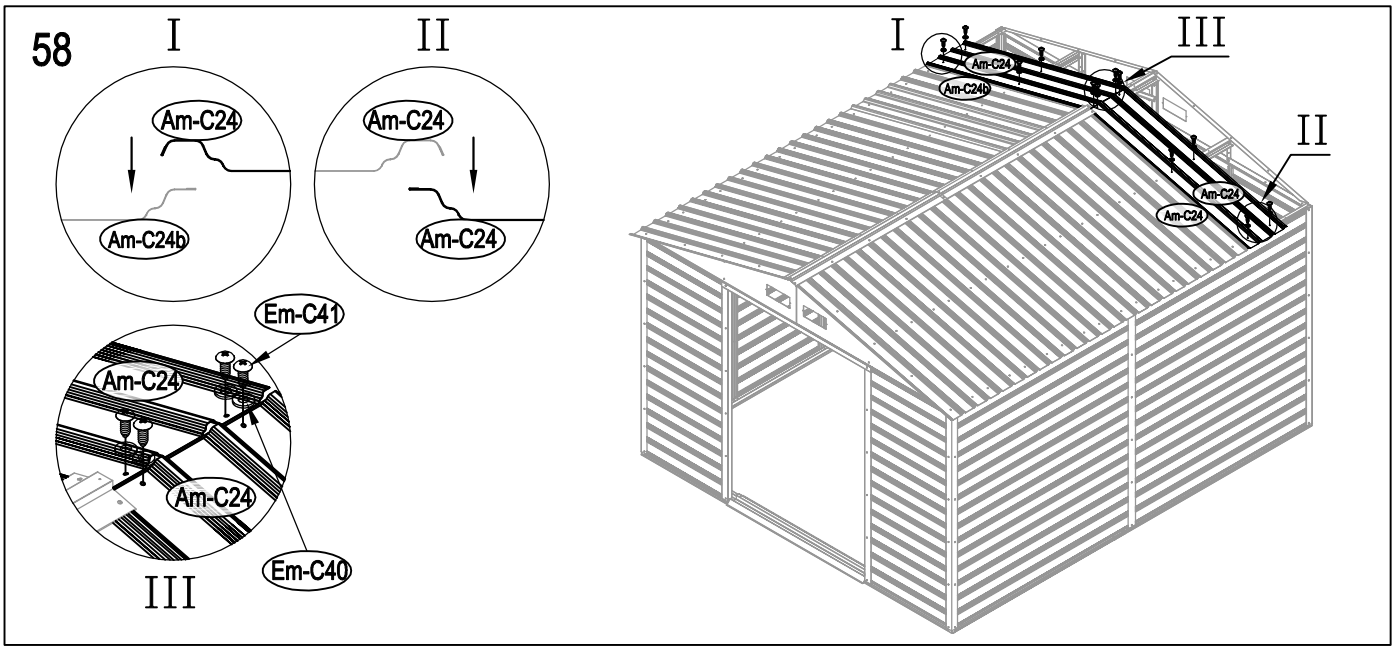

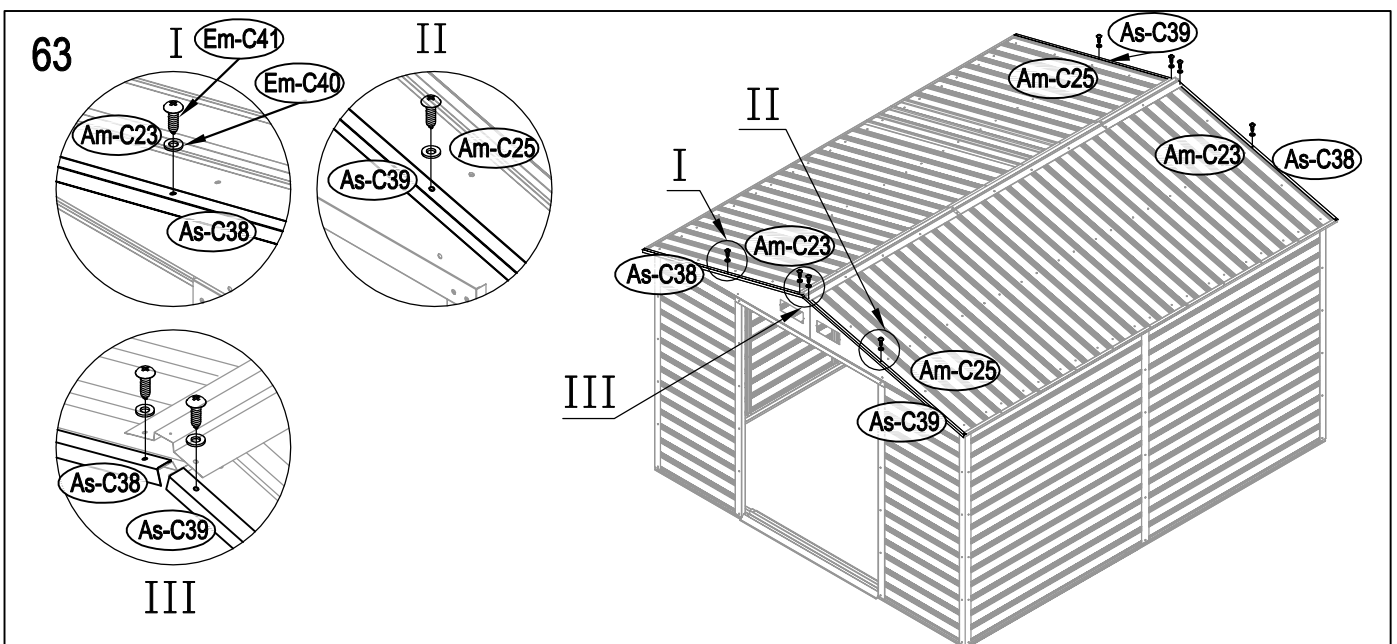
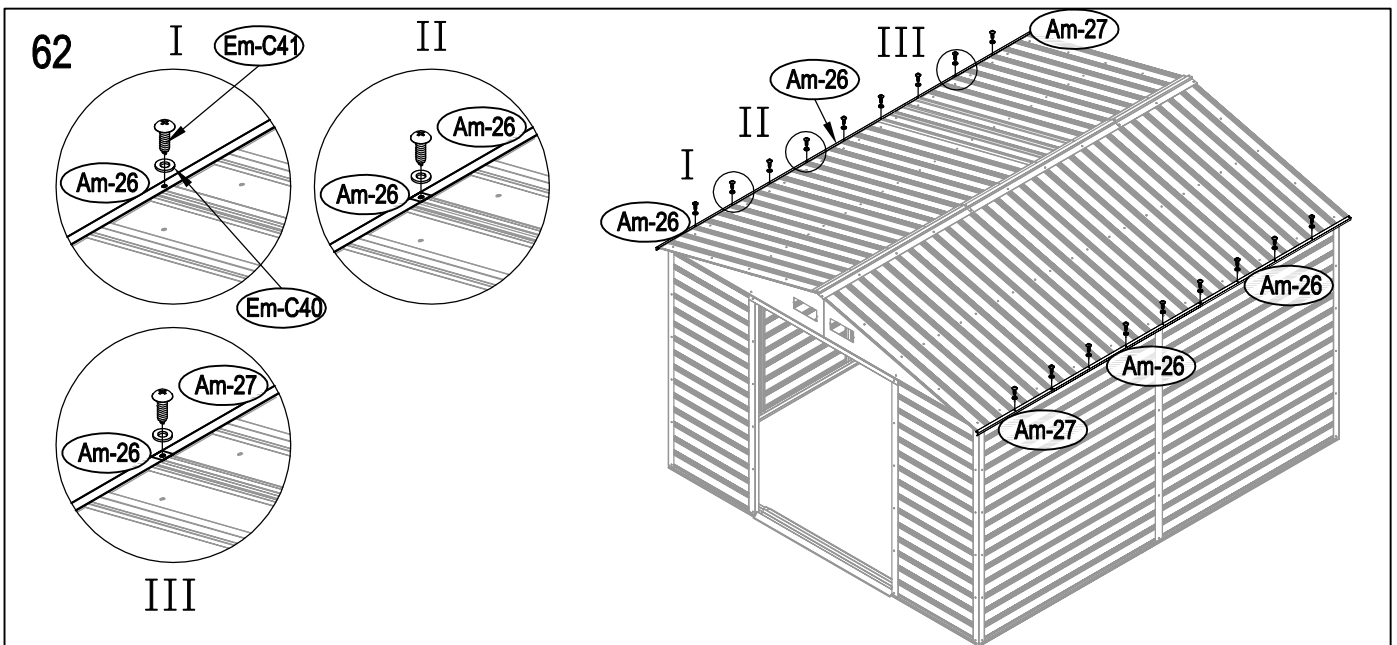
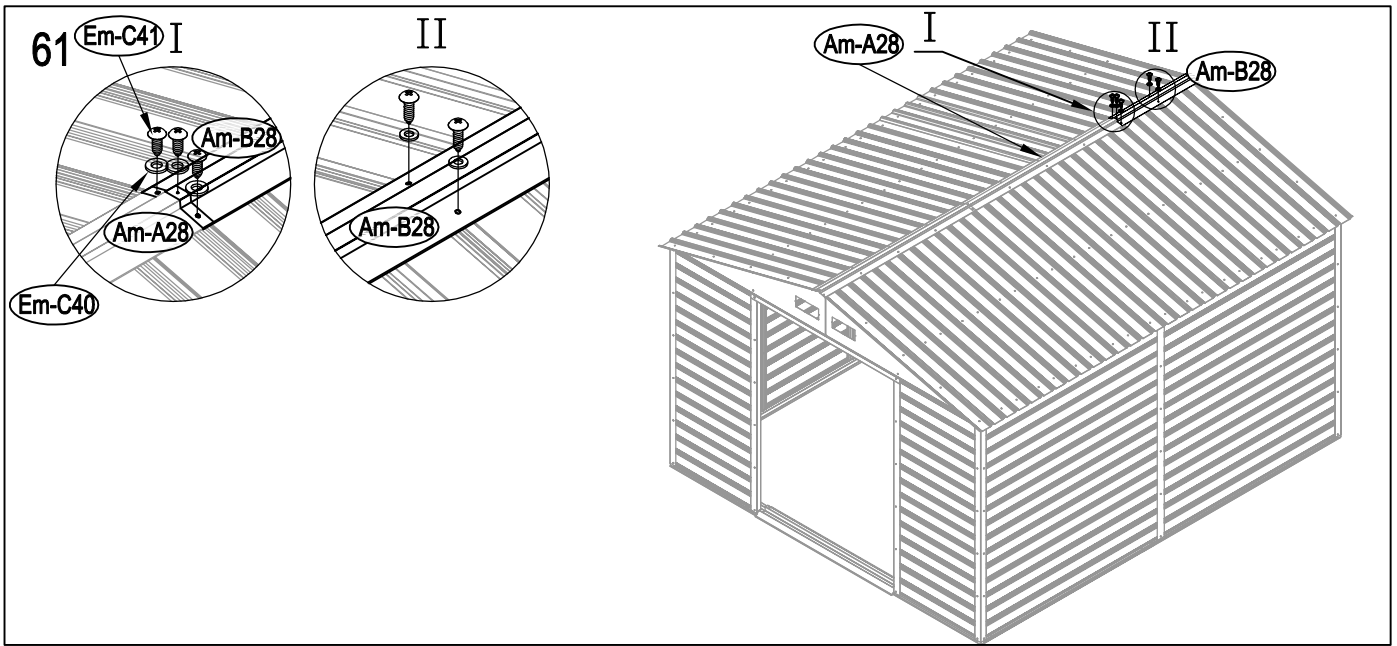

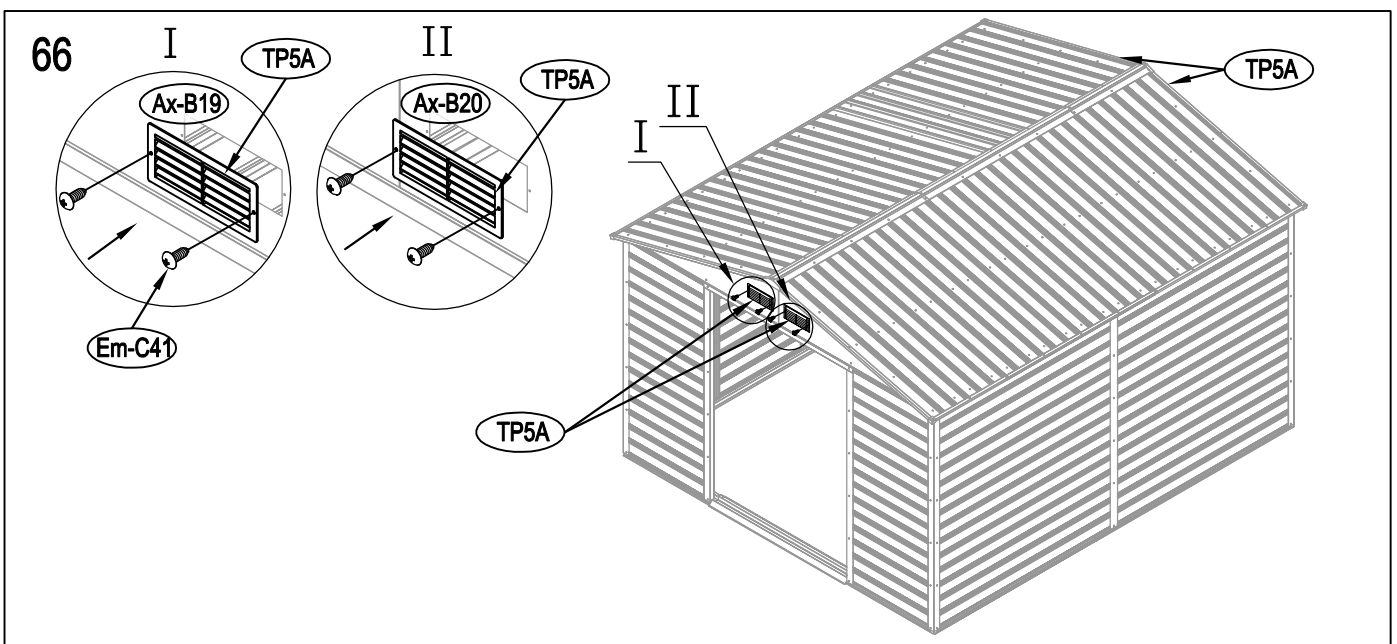
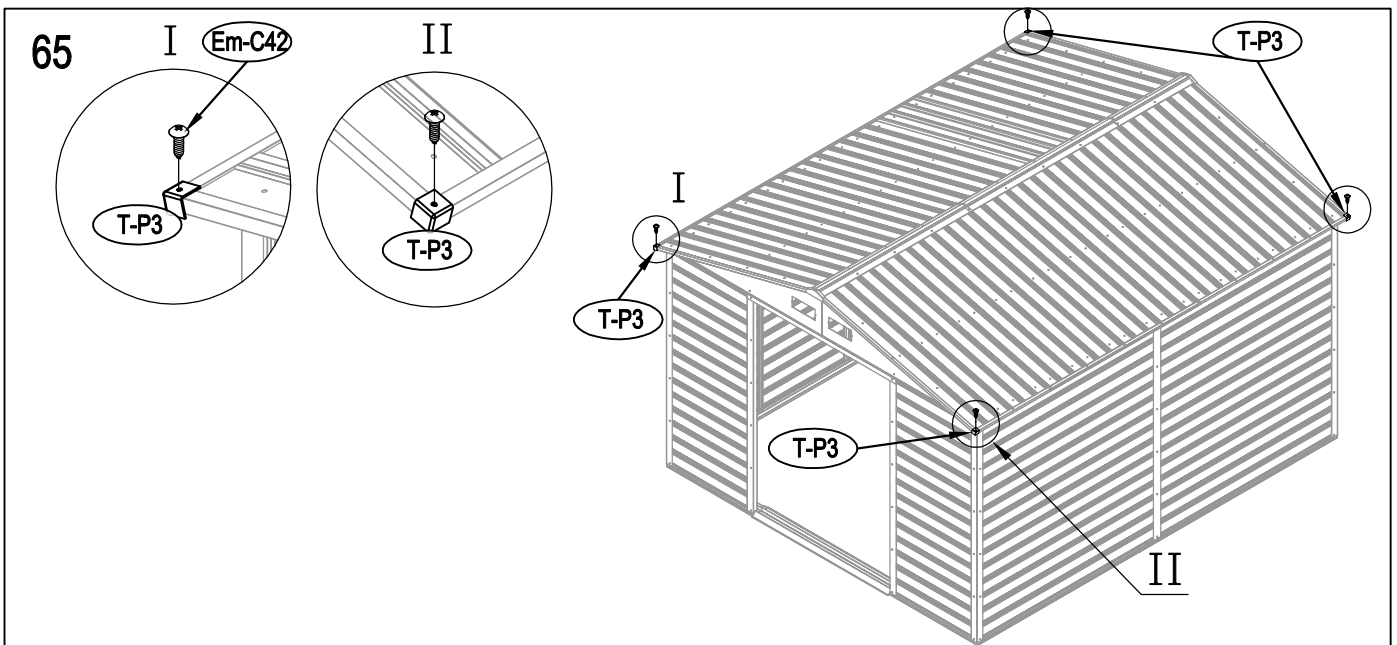
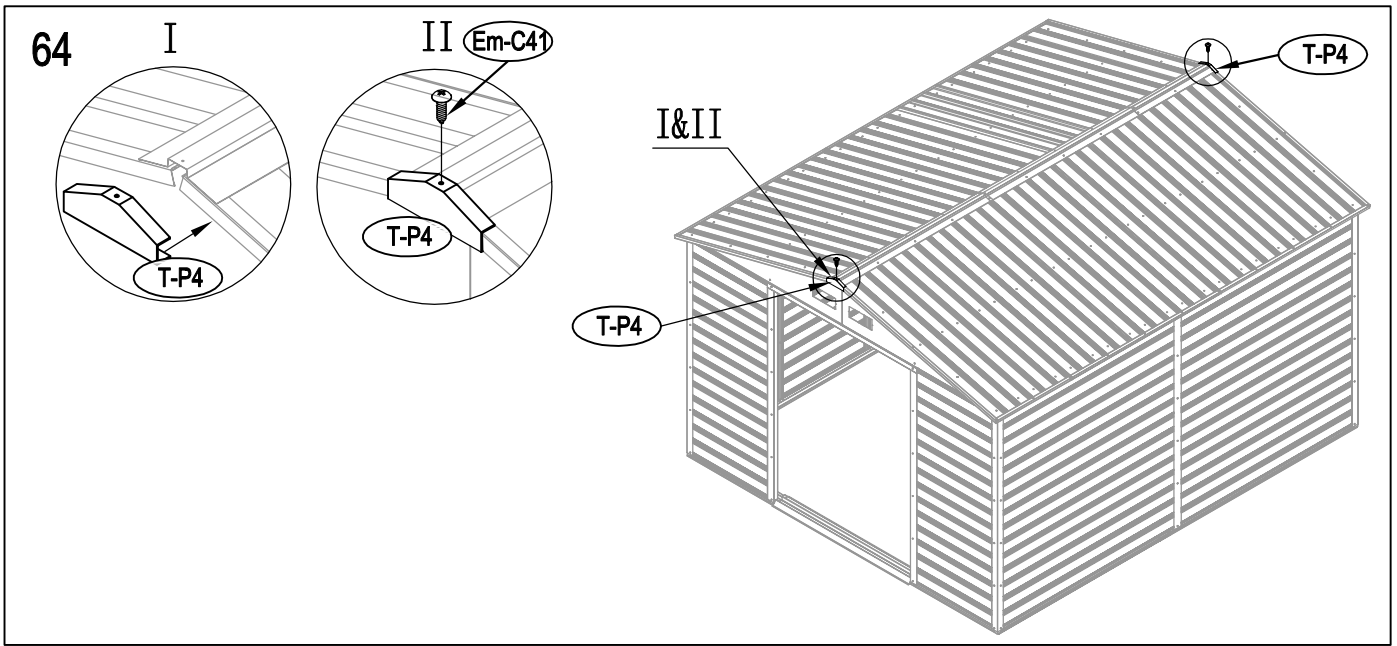

67

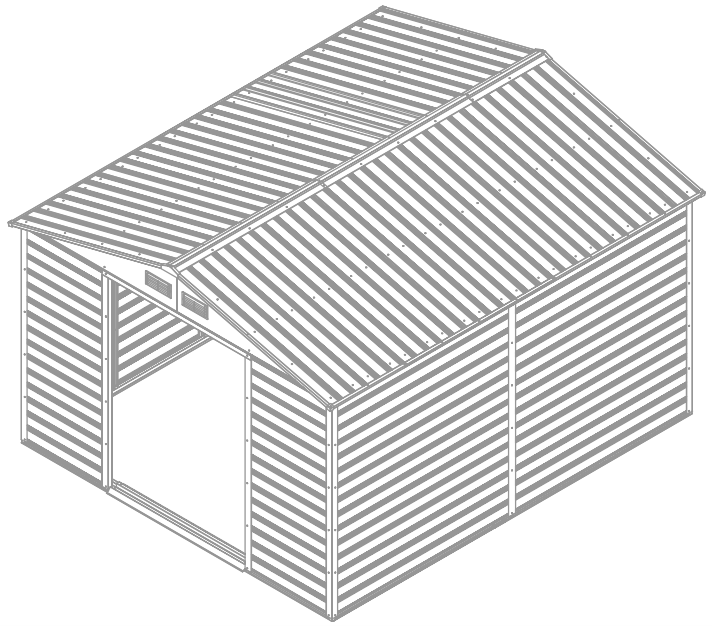
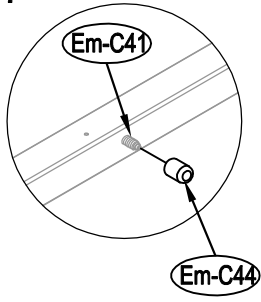

68

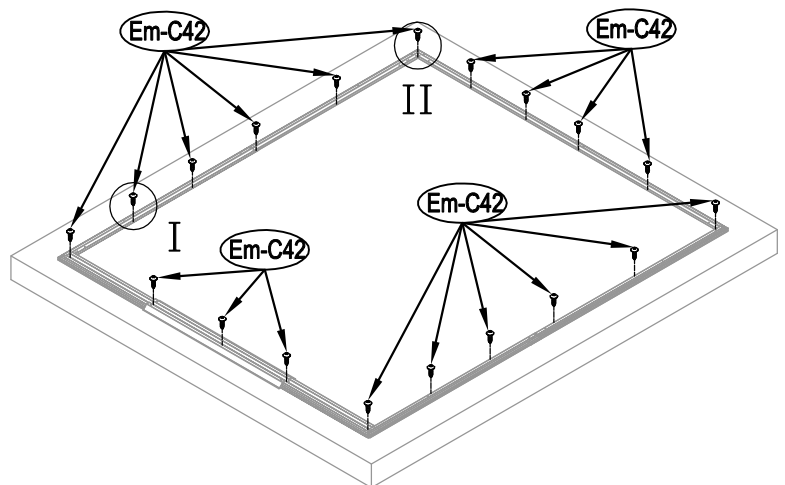
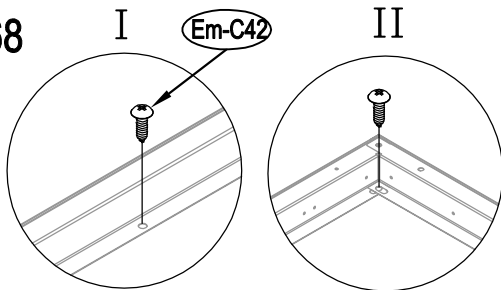

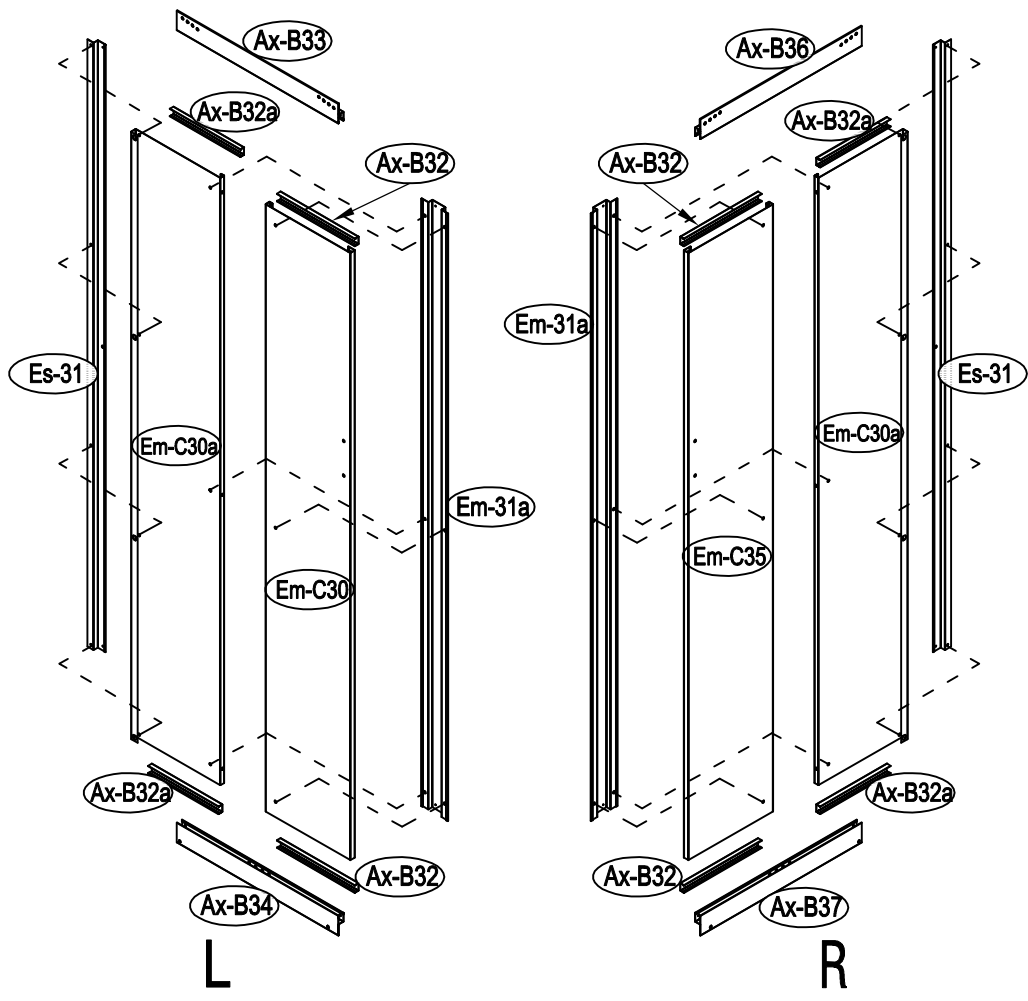

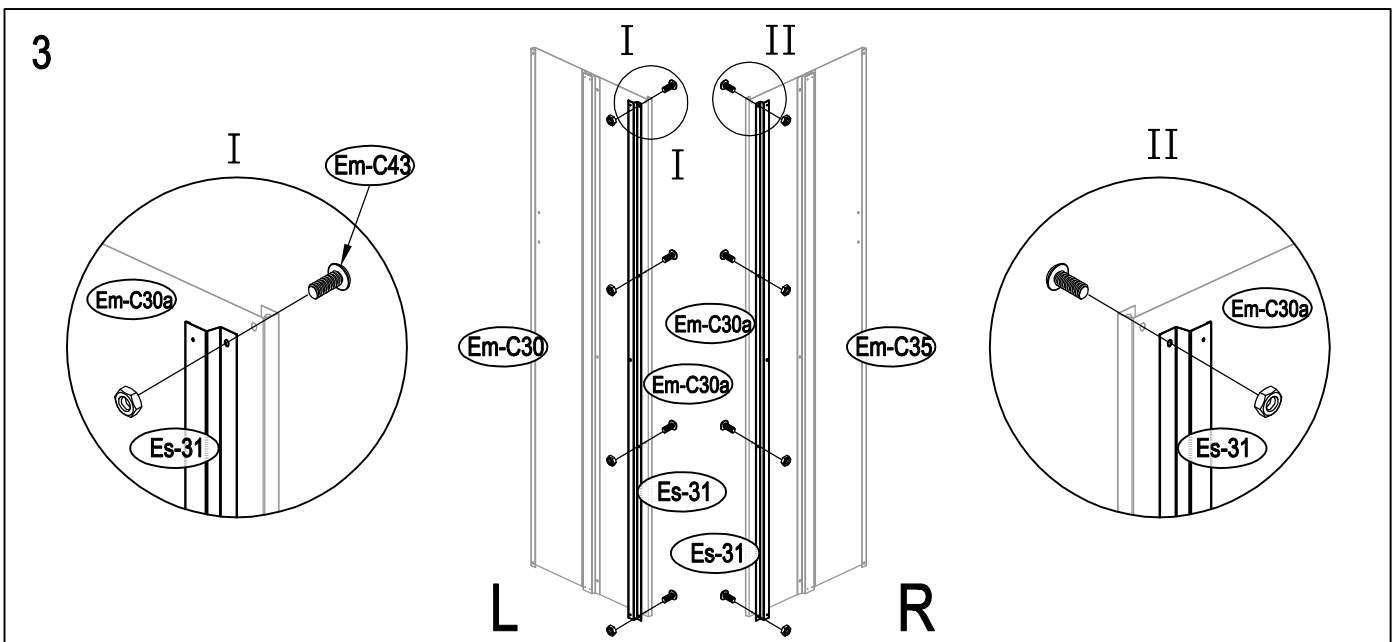
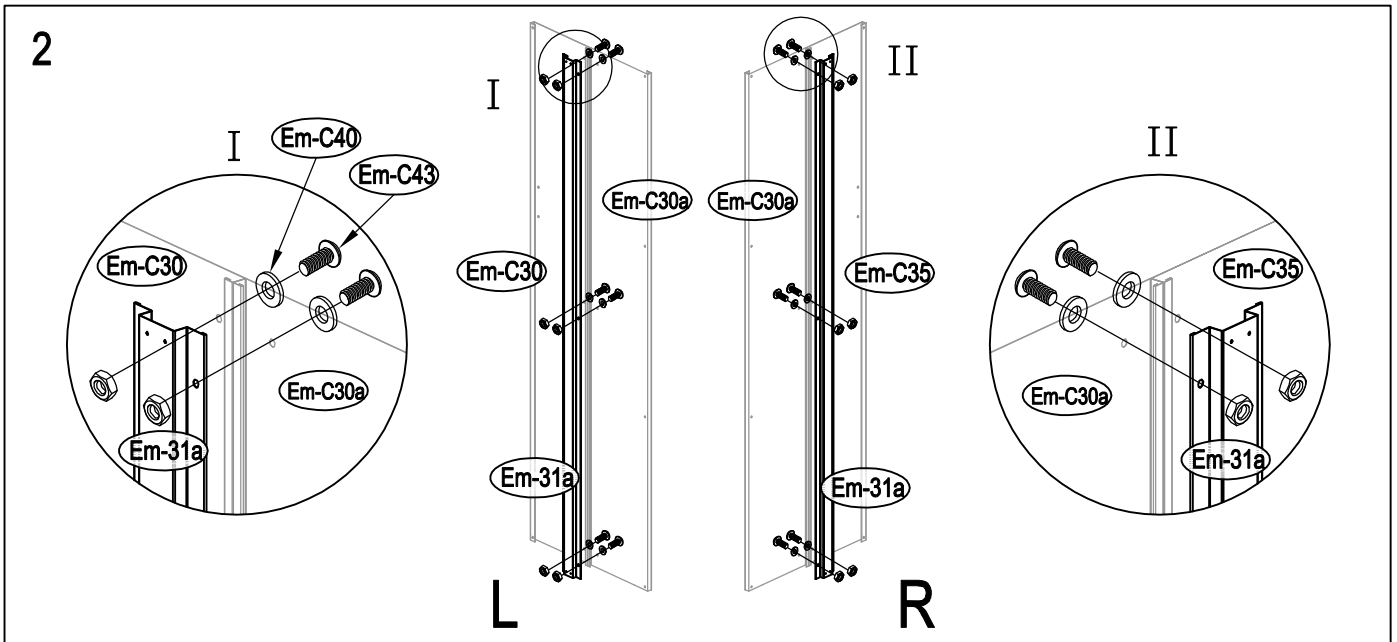
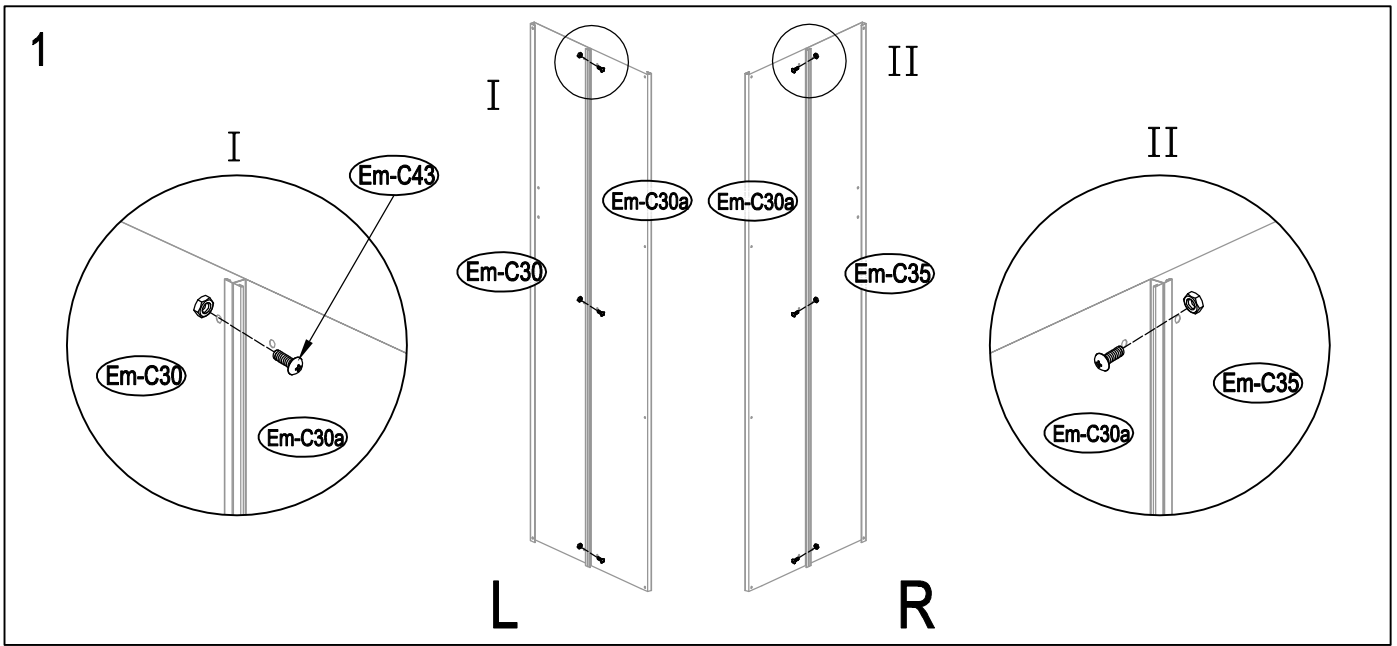

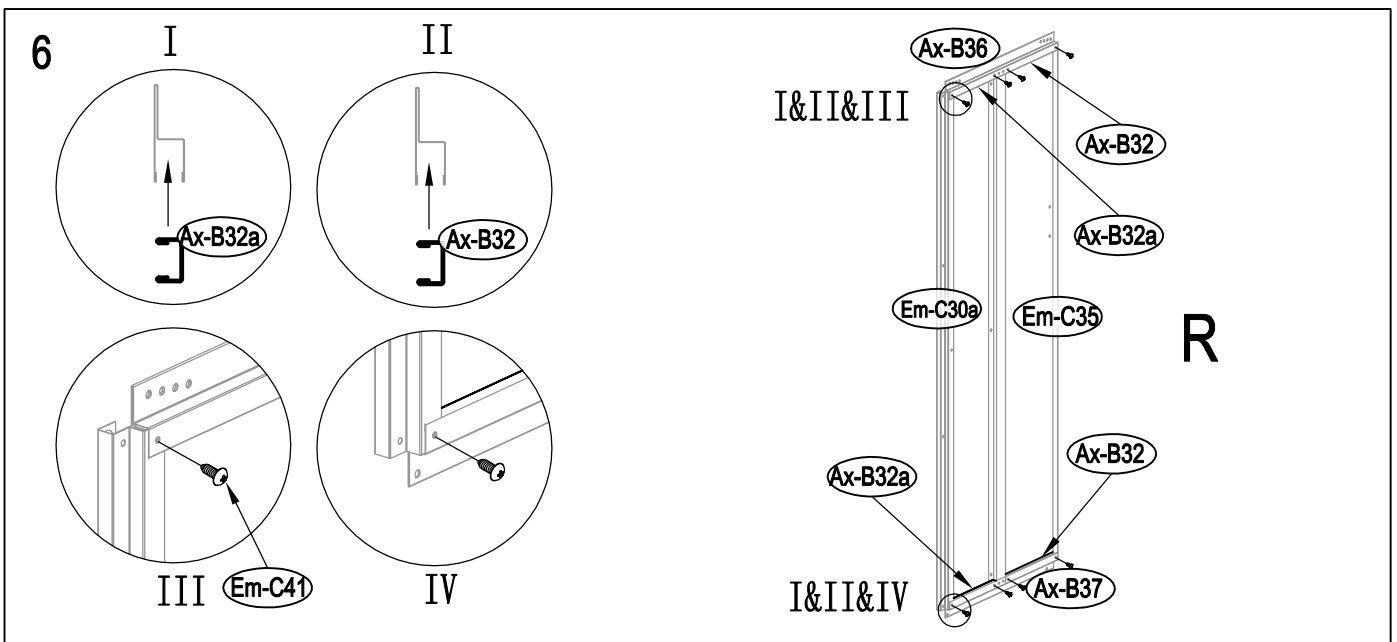
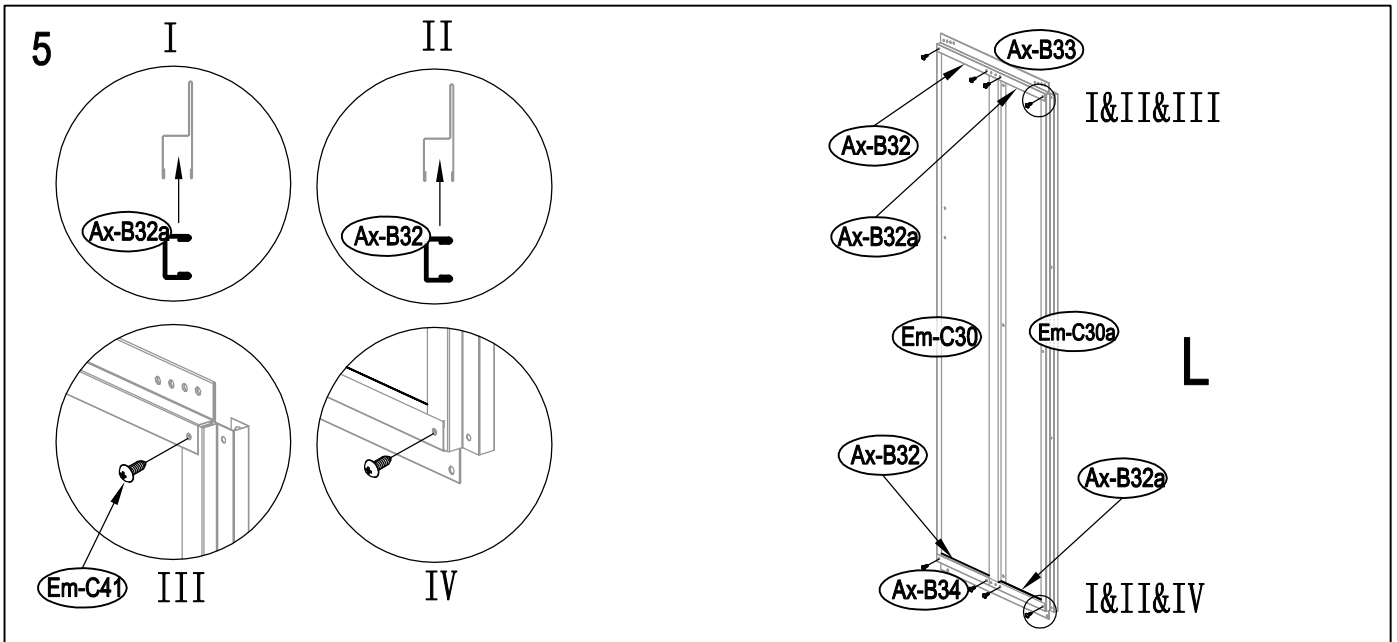
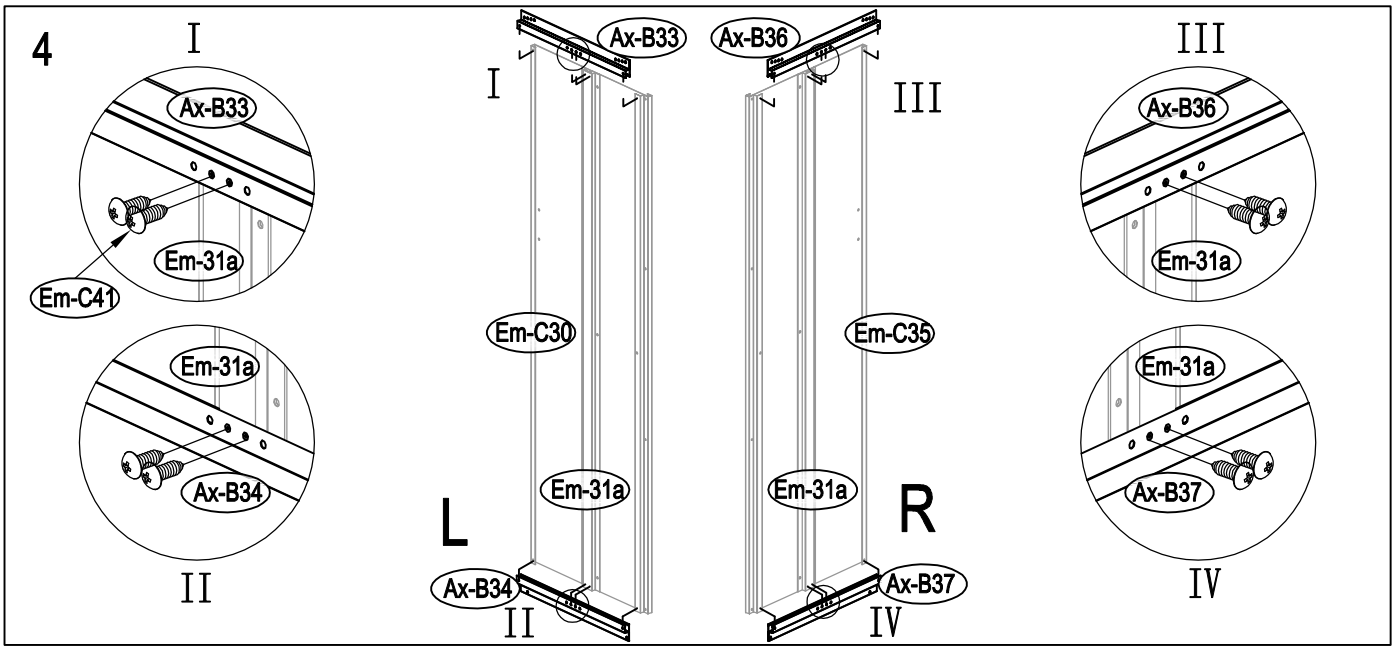

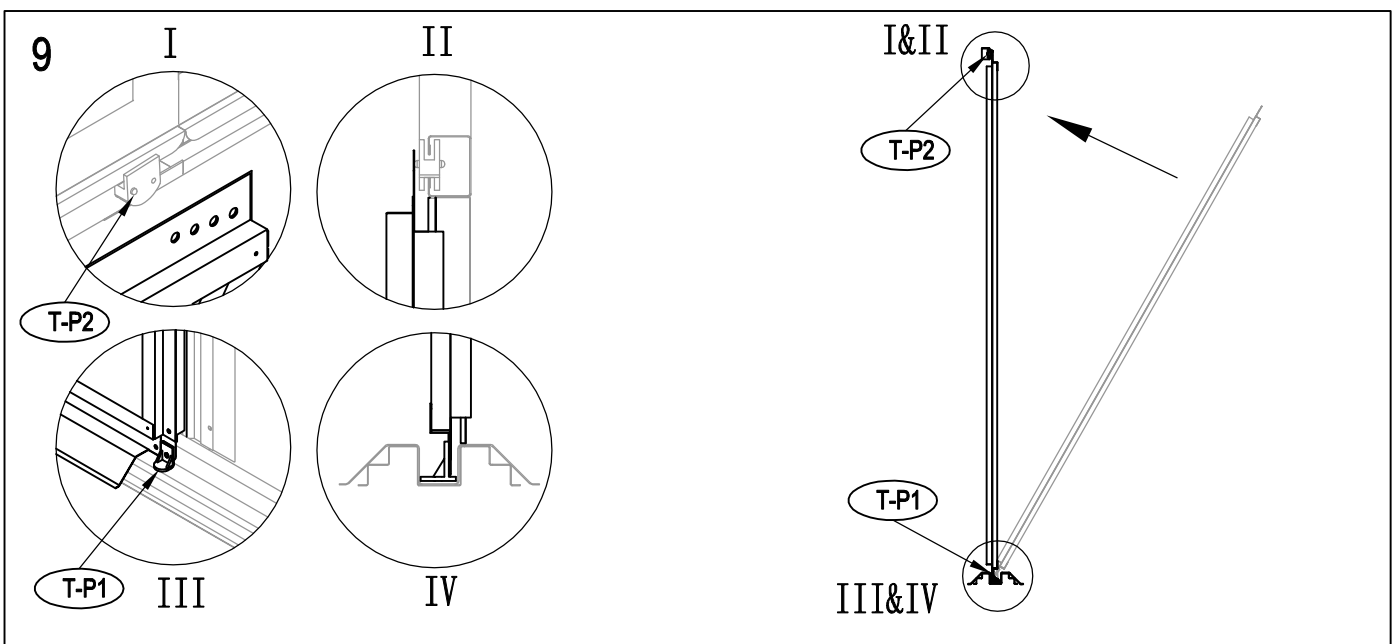
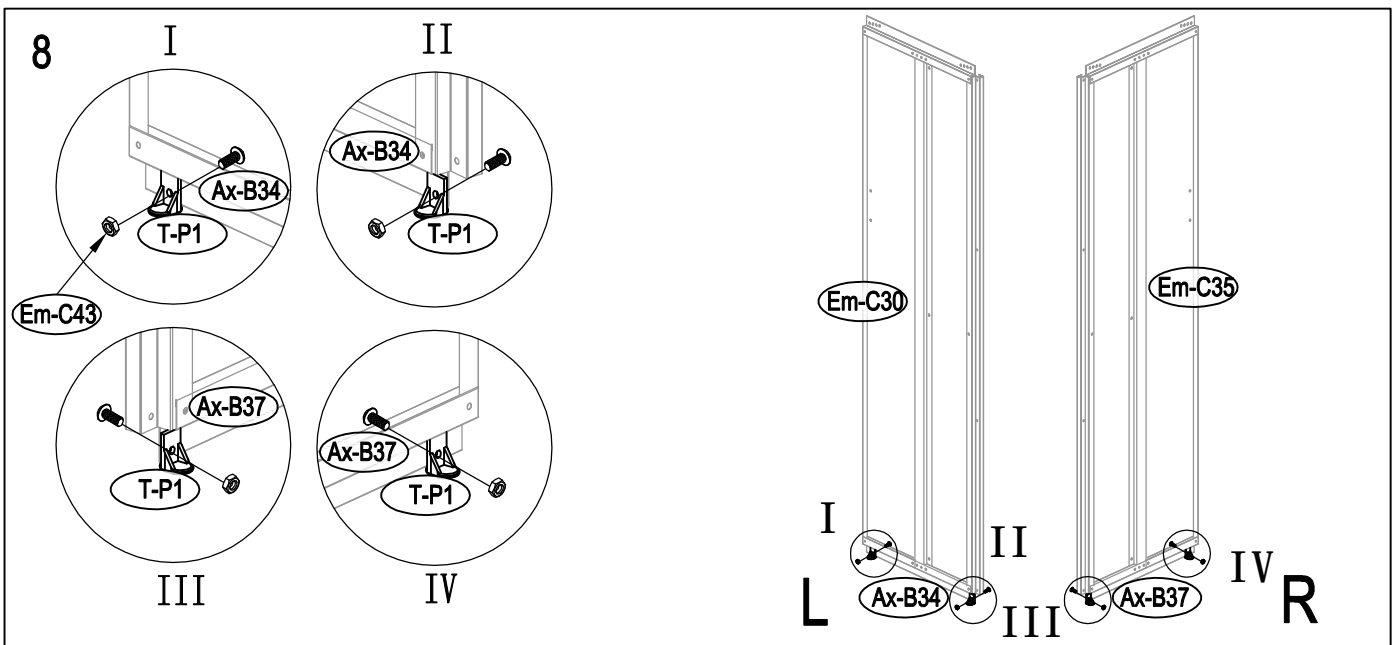
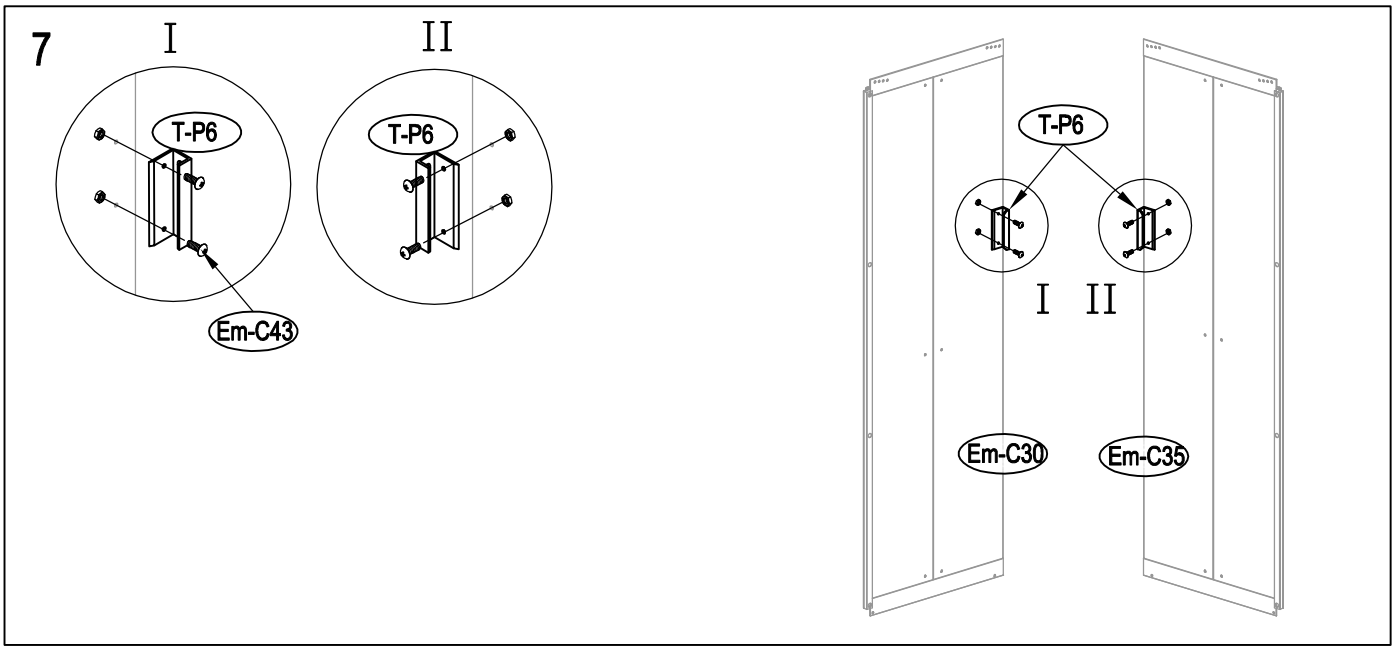

10

I

II

I&II&III

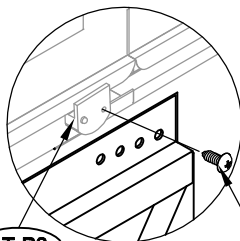
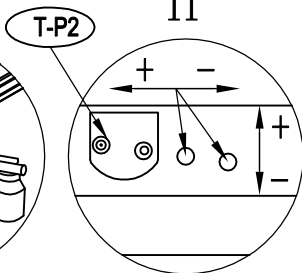
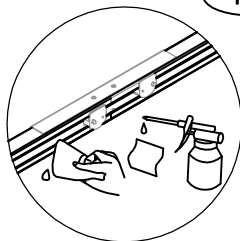

III

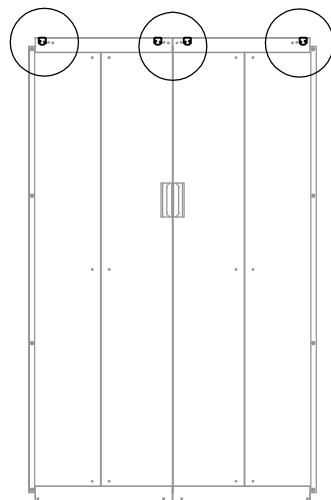

11

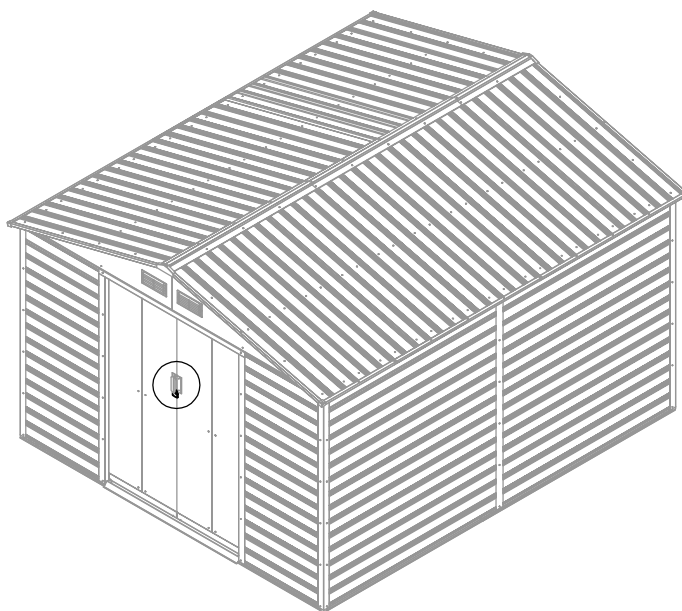
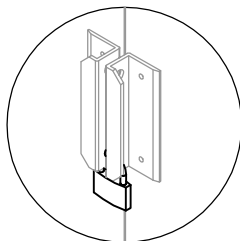

Foundation Kit Assembly Instructions

The foundation kit can be used as base for plywood, sand or stone. PLEASE NOTE: Decking material and Self Drilling Screws for flooring are not supplied, the owner can buy them locally.

Before You Begin:

1. SAFETY FIRST: Care must be taken when handling various pieces of your kit since some contain sharp edges. Please always wear work gloves (2 pairs of gloves are provided with the shed for safe construction), eye protection and long sleeves when assembling or performing any maintenance on your kit.
2. GROUND MUST BE LEVEL! Be sure foundation kit frames lie flat on ground. To prepare the earth bed, remove sod and other organic debris, level the high spots with a flat shovel, and tamp the bed down.
3. DO NOT STEP ON CHANNELS until flooring material is in place!
4. Be sure all the parts fit together properly before proceeding.

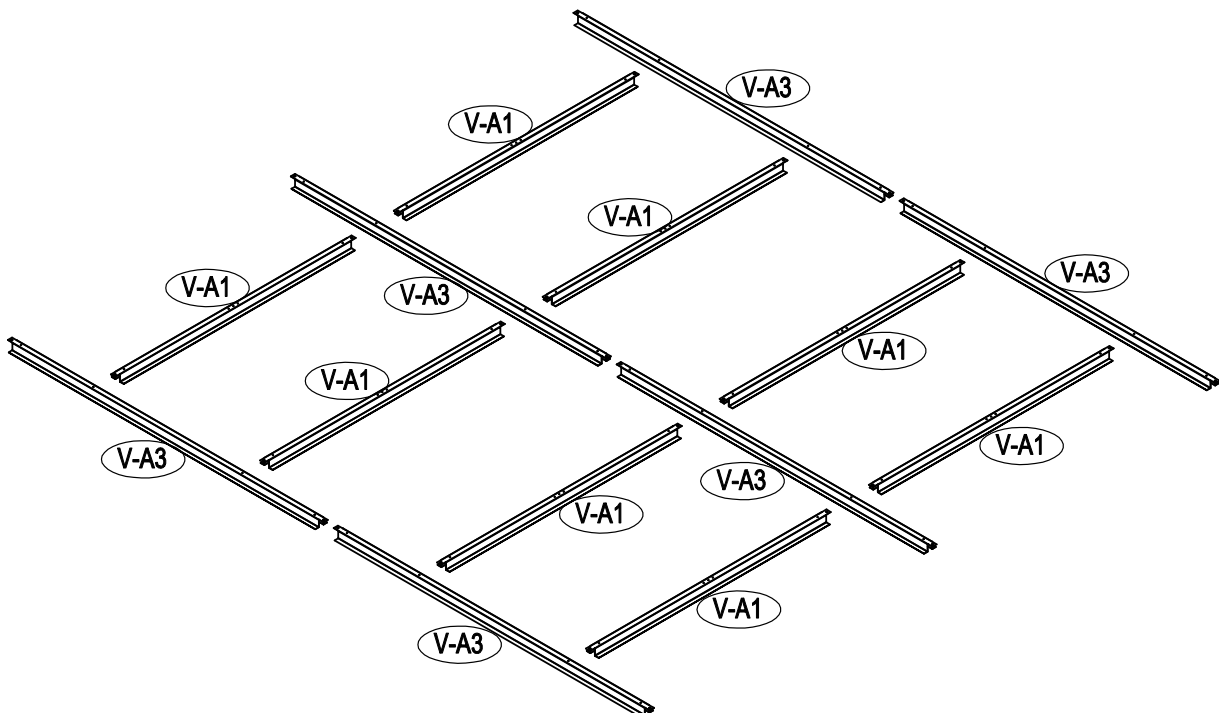

Plywood Flooring

NOTE: Decking material and self drilling screws for flooring are not supplied, the owner can buy them from local stores.

A) Plywood requirement:

Recommended minimum thickness: 16mm (5/8"), **Exterior Grade.**

NOTE:

Pressure Treated Lumber **must not** be used because it may cause corrosion when in contact with metal shed.

Recommended dimensions and qtys for plywood flooring

Image	mm	Qty
	354x974x16	2
	354x1008x16	2
	354x1025x16	2
	634x974x16	2
	634x1008x16	2
	634x1025x16	2
	655x974x16	1
	655x1008x16	1
	655x1025x16	1

B) 25-35mm long self drilling screws to secure Plywood Flooring.

Image	mm	Qty
	st4.2x25~35	44



1. Make sure the foundation kit frames are square and level .

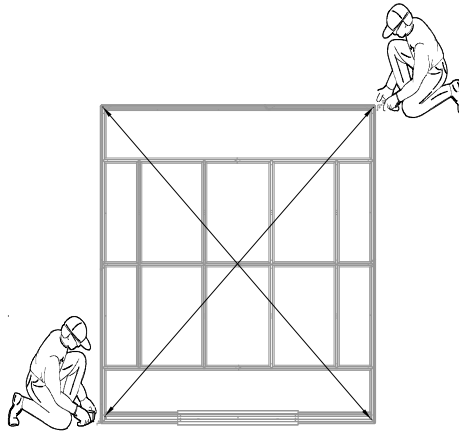

2. Cut Plywood to recommended dimensions.

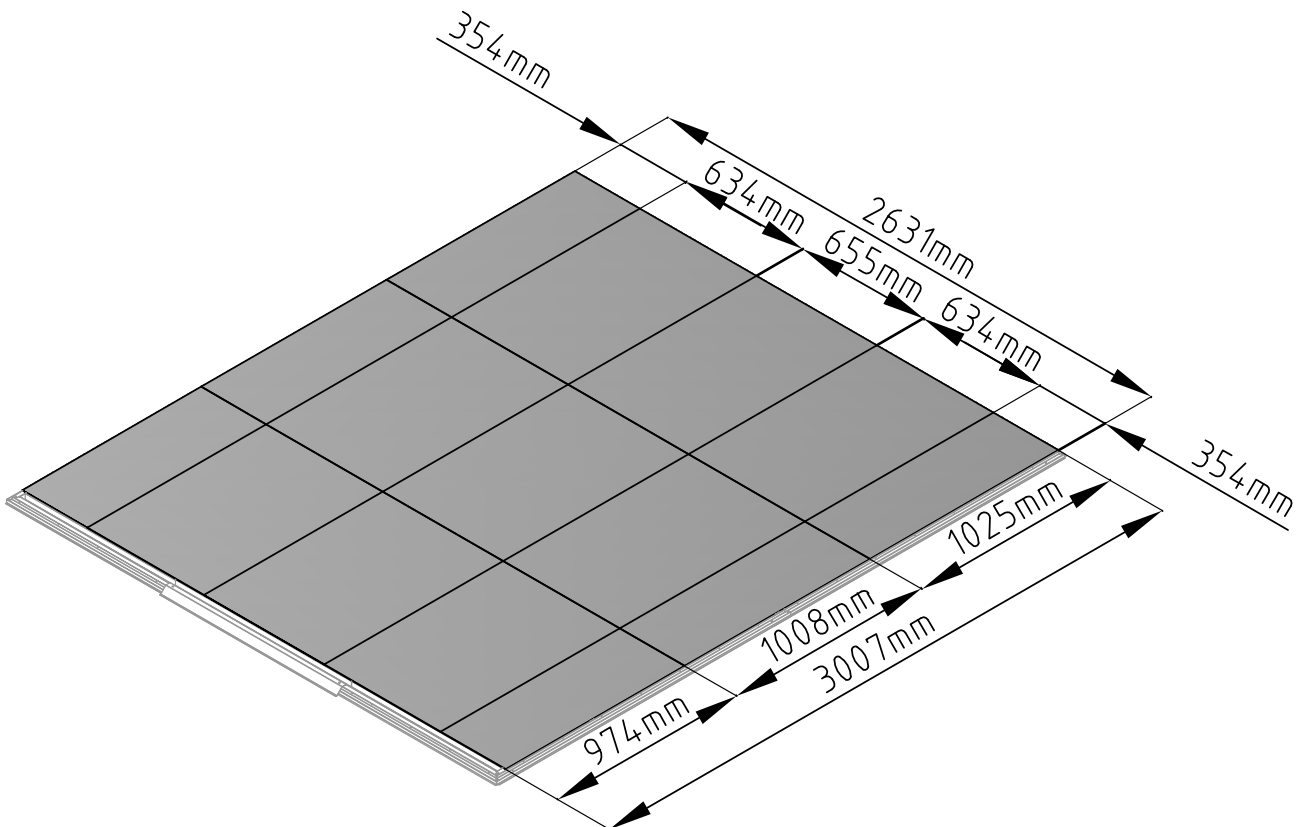

3. Fasten Plywood to foundation kit frames with self drilling screws .

