

Assembly Instructions

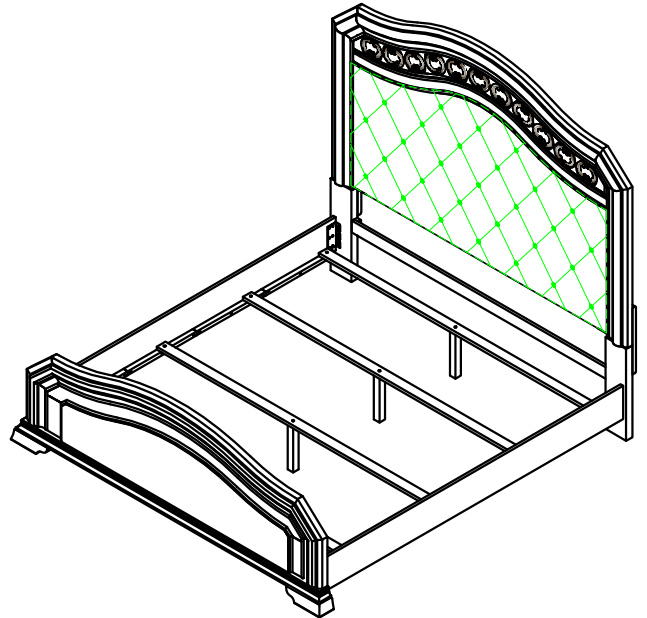
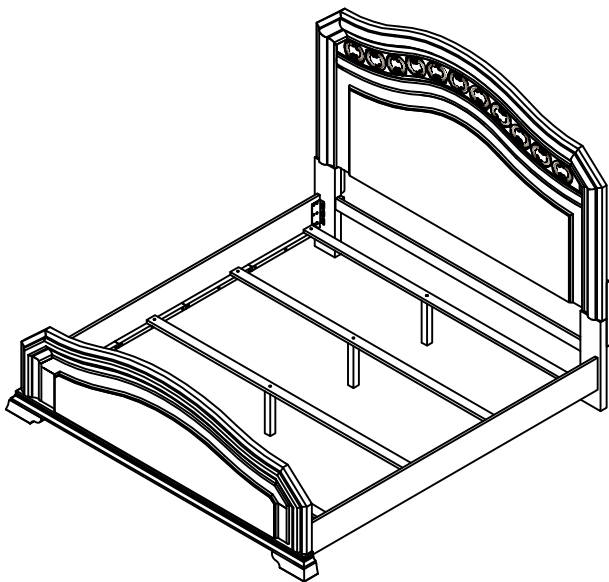

ASSEMBLY RATING

The Assembly Rating is a 5-point system that shows the degree of effort needed in assembling a specific product (with 1 being easy and 5 being difficult). For some products, two persons are recommended.

EASY  DIFFICULT

Tools Required For Assembly:

Allen Wrench

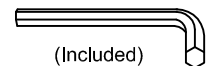

(Included)

Phillips Screwdriver



(Not Included)

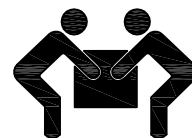

2 PERSONS RECOMMENDED

ASSEMBLY & CARE ADVICE

FOR YOUR FURNITURE TO LAST, CORRECT ASSEMBLY AND PROPER MAINTENANCE ARE NECESSARY. PLEASE FOLLOW THE INFORMATION PROVIDED BELOW TO FULLY ENJOY YOUR FURNITURE.

BASIC ASSEMBLY TECHNIQUES



When lock or spring washer is used in an assembly, please make sure the lock or spring washer is placed between the larger flat washer and the head of the screw or bolt.



Position each part correctly and insert screws or bolts into their respective holes by hand tighten or using the proper hand tool. Only tighten when step is completed or when instructed to do so.



Use cardboard or carpet area when assembling furniture to prevent scratches. Make sure the furniture rests on a flat and level surface with each leg evenly touching the floor.



Some furniture comes with height adjustment knobs underneath each leg. To lower or to raise each leg, you need to turn clockwise or counterclockwise, respectively.



Make sure all parts are properly aligned, then use the appropriate hand tool to completely tighten the bolts or screws. Do not use power tools and do not overtighten.



Save the instructions and store the Allen wrench or any supplied tool for later maintenance. After two weeks, check and tighten any loose hardware and repeat again every six months thereafter.

IT IS THE USER'S RESPONSIBILITY TO MAINTAIN THE FURNITURE. THE HARDWARE MAY LOOSEN OVER TIME AND MAY CAUSE THE FURNITURE TO BE WOBBLY AND UNABLE TO SUPPORT ITS INTENDED WEIGHT CAPACITY. THIS MAY LEAD TO COLLAPSE AND MAY CAUSE SERIOUS INJURY.

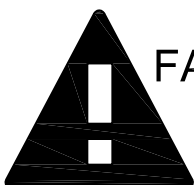

FAILURE TO FOLLOW THE GUIDELINES ABOVE MAY RESULT IN INJURY AND/OR PROPERTY DAMAGE.

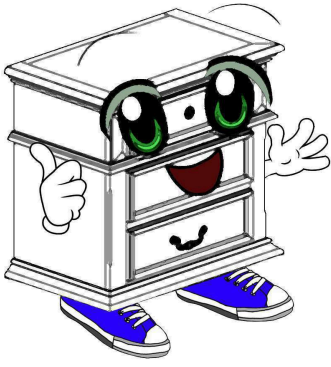

Before you begin, please read Page 2 of "Assembly and Care Advice".

And remember, do not tighten until each step is completed or instructed.

Parts List



#1 x 1pc
Headboard

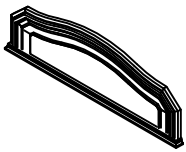

#2 x 1pc
Footboard

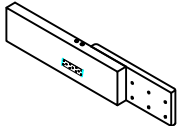

#3 x 2pcs
Headboard Leg(L&R)

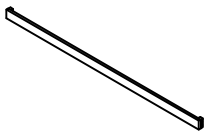

#4 x 1pc
Headboard Support

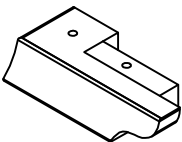

#5 x 2pcs
Footboard Leg(L&R)



#6 x 2pcs
Side Rail



#7 x 4pcs
Slat



#8 x 4pcs $\text{\O}1/4$
Support Leg 35x35x200mm

Hardware List



#A x 16pcs
Bolt $\text{\O}1/4$ "x1-3/4"



#B x 4pcs
Bolt $\text{\O}1/4$ "x2"



#C x 12pcs
Bolt $\text{\O}5/16$ "x1"



#D x 20pcs
Lock Washer $\text{\O}1/4$ "



#E x 20pcs
Flat Washer $\text{\O}1/4$ "x13



#F x 1pc
Allen Wrench M4

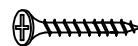

#G x 8pcs
Screw #4x30

Exploded View

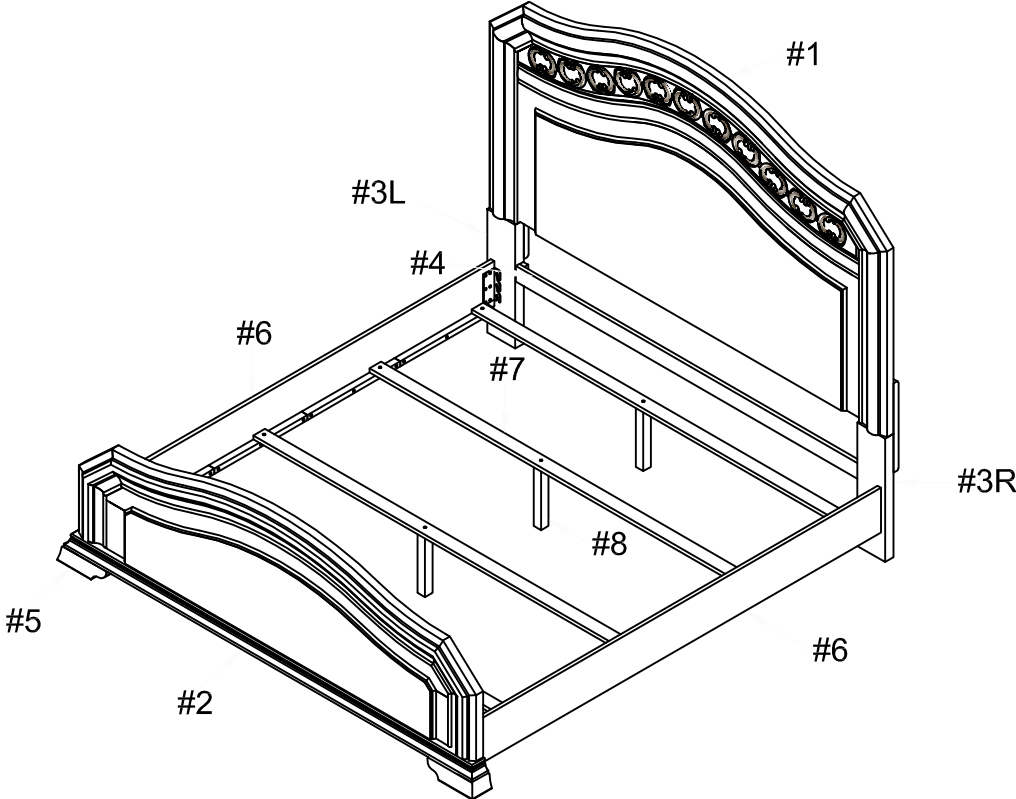

Prepare 12 bolts assembly by inserting lock washer (#D), then flat washer (#E) onto bolts (#A). Align HB legs (#3R/L) to the holes of the headboard (#1). Secure by using bolts (#A).

- #A x 12 pcs
- #D x 12 pcs
- #E x 12 pcs

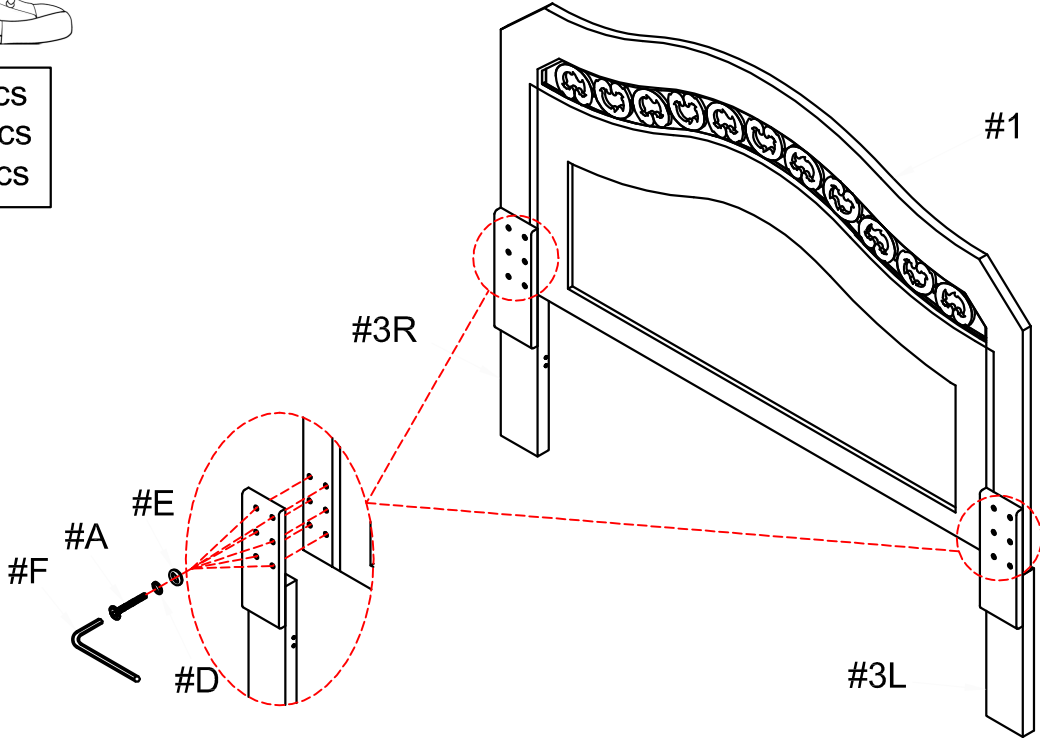



Prepare 4 bolts assembly by inserting lock washer (#D), then flat washer (#E) onto bolts (#A). Align headboard support (#4) to the holes of the headboard legs (#3R/L), then secure by using bolts (#A).

#A x 4 pcs
#D x 4 pcs
#E x 4 pcs

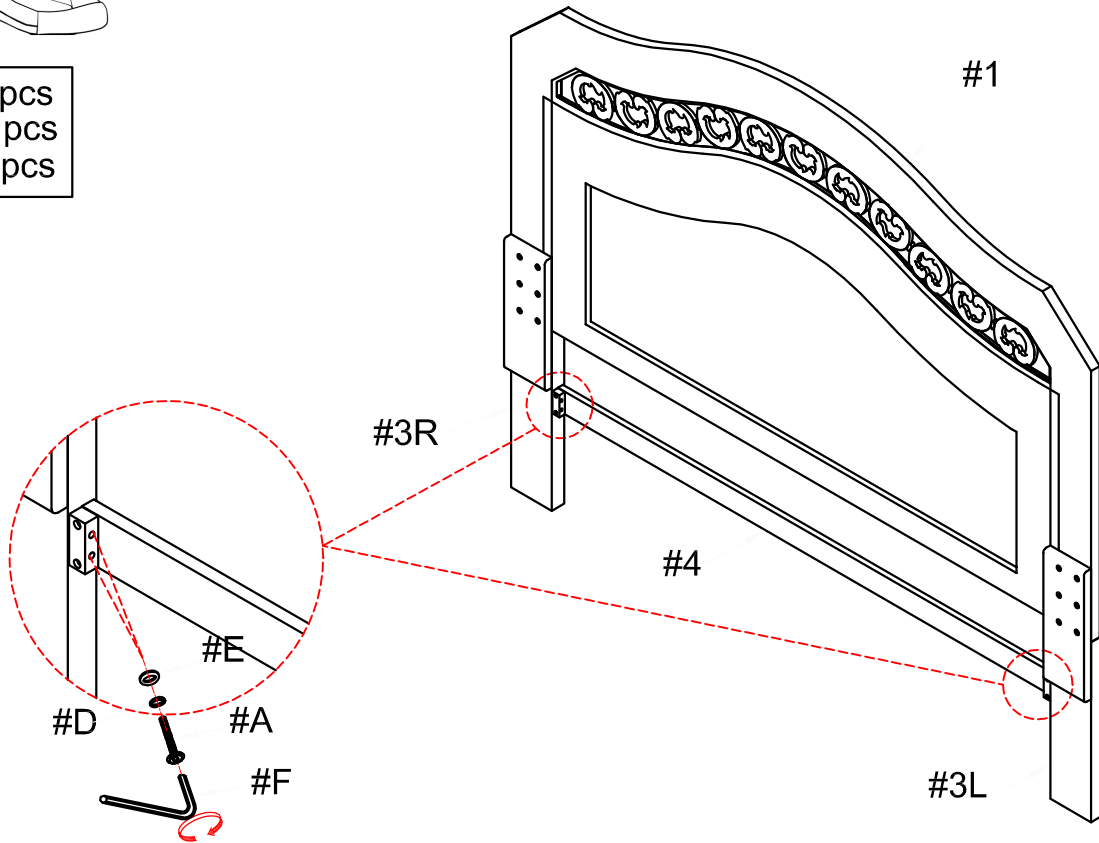

Prepare 4 bolts assembly by inserting lock washer (#D), then flat washer (#E) onto bolts (#B). Align legs (#5R/L) to the holes of the footboard (#2). Secure by using bolts (#B).

#B x 4 pcs
#D x 4 pcs
#E x 4 pcs

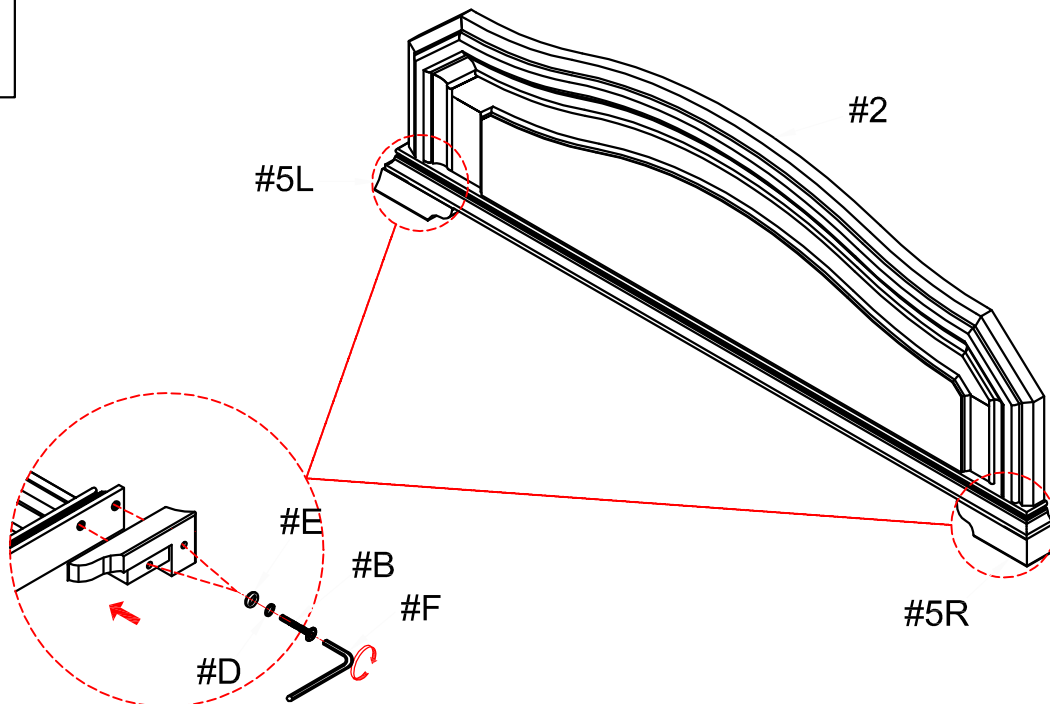



#4

#C x 12 pcs

Attach bolts (#C) half way into the holes of the headboard (#1) and footboard (#2).
Align and hook side rails (#6) to the bolts (#C). Secure by tightening bolts (#C).

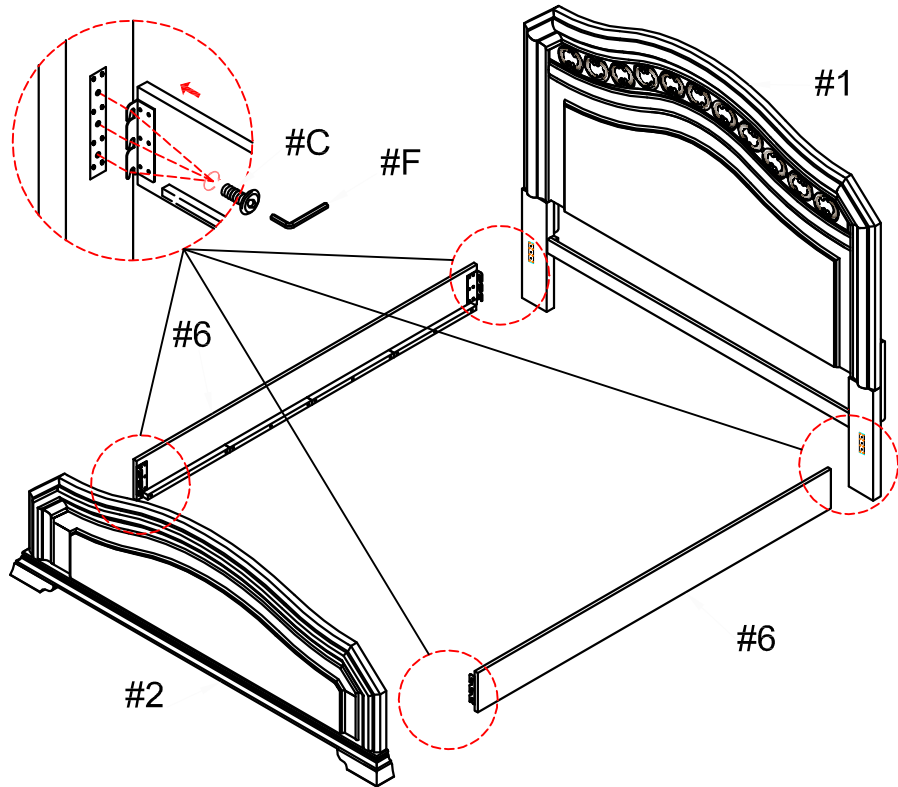

#5

Attach support legs (#8) to the holes of the slats (#7), then adjust the leveler on the support legs (#8) according to ground level.

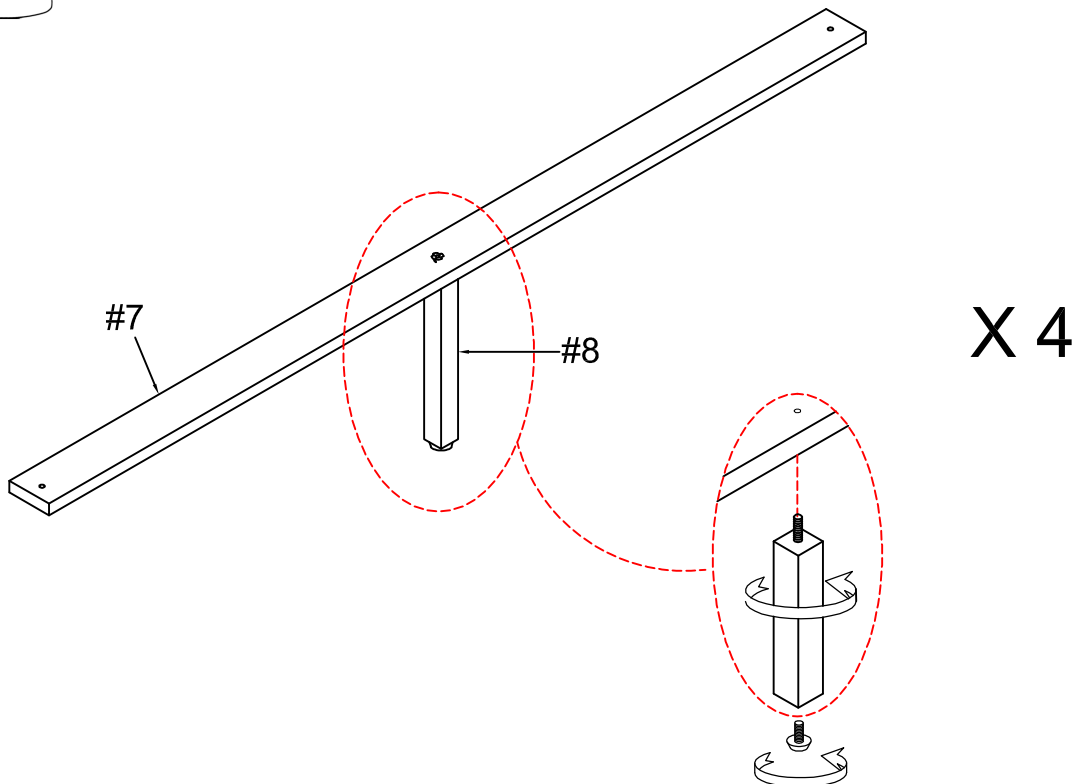



#6

Align slats to the side rails, secure by using screws (#G).

#G x 8 pcs

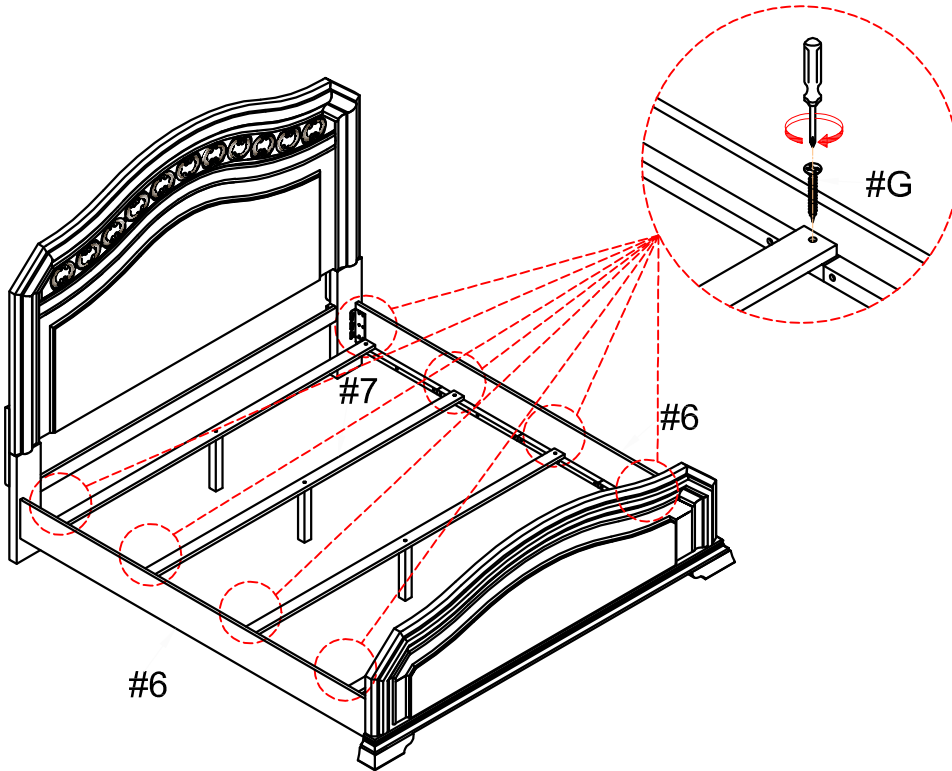

#7

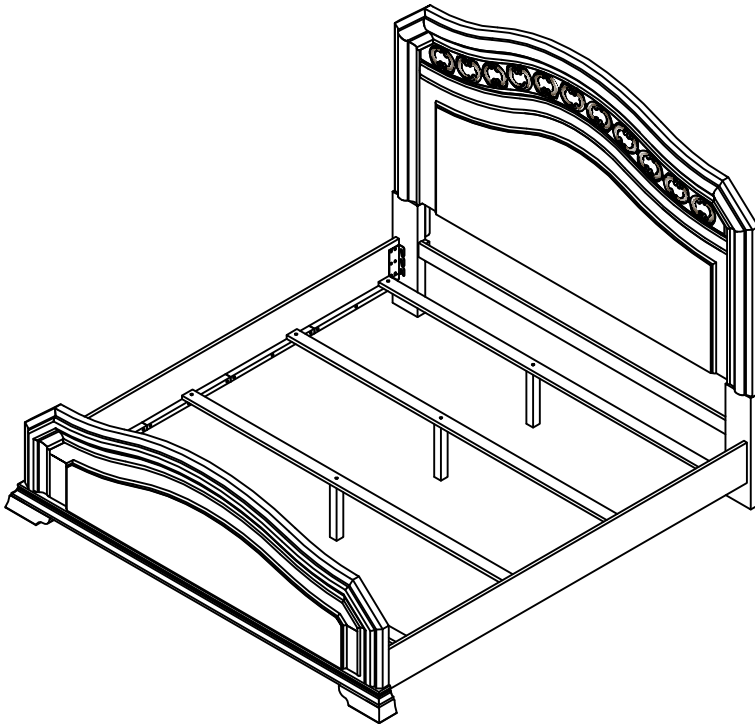

ASSEMBLY IS COMPLETED

Assembly Instructions

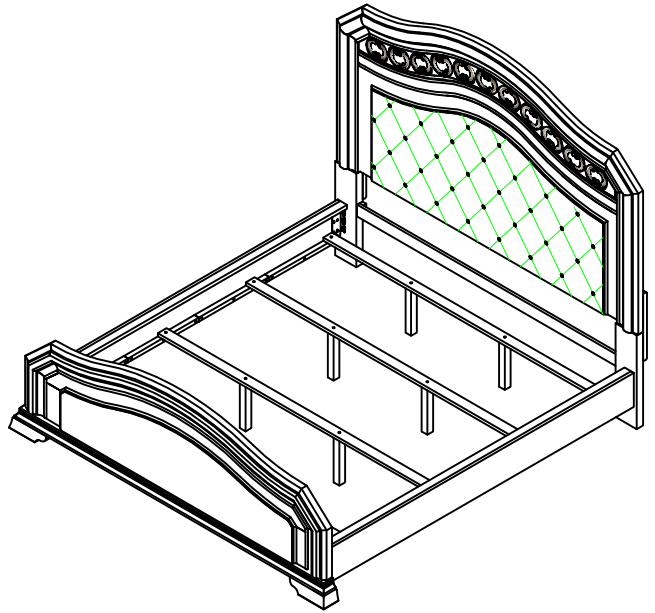
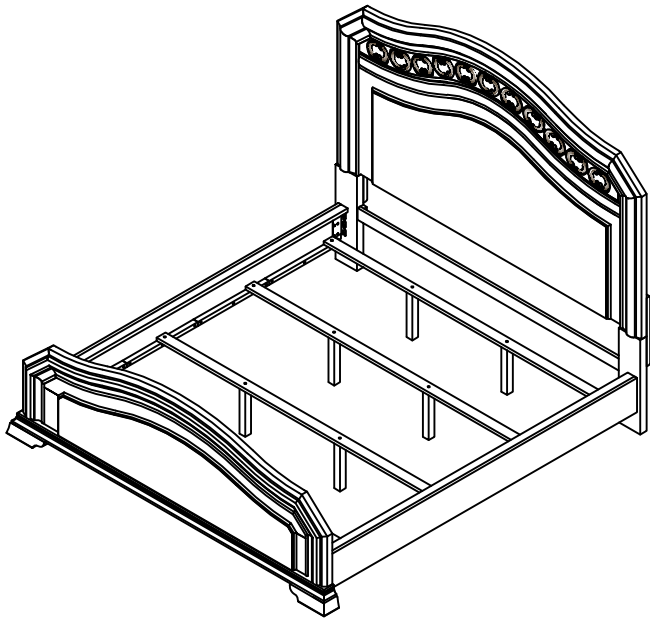

ASSEMBLY RATING

The Assembly Rating is a 5-point system that shows the degree of effort needed in assembling a specific product (with 1 being easy and 5 being difficult). For some products, two persons are recommended.

EASY  DIFFICULT

Tools Required For Assembly:

Allen Wrench

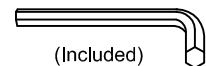

(Included)

Phillips Screwdriver



(Not Included)

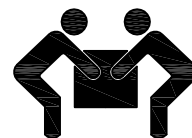

2 PERSONS RECOMMENDED

ASSEMBLY & CARE ADVICE

FOR YOUR FURNITURE TO LAST, CORRECT ASSEMBLY AND PROPER MAINTENANCE ARE NECESSARY. PLEASE FOLLOW THE INFORMATION PROVIDED BELOW TO FULLY ENJOY YOUR FURNITURE.

BASIC ASSEMBLY TECHNIQUES

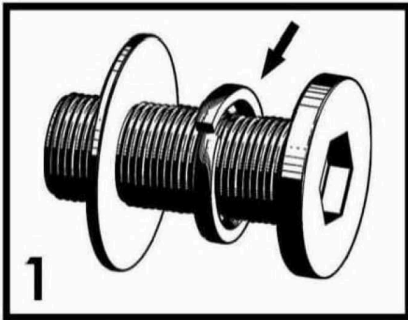

When lock or spring washer is used in an assembly, please make sure the lock or spring washer is placed between the larger flat washer and the head of the screw or bolt.

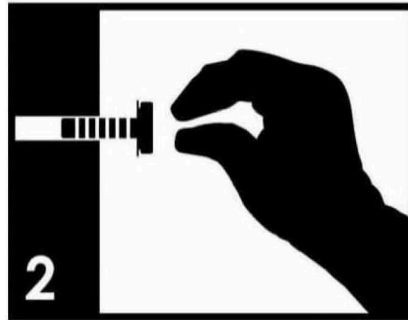

Position each part correctly and insert screws or bolts into their respective holes by hand tighten or using the proper hand tool. Only tighten when step is completed or when instructed to do so.

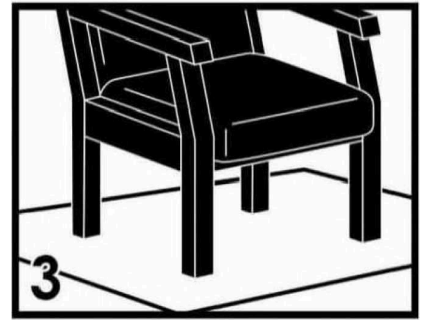

Use cardboard or carpet area when assembling furniture to prevent scratches. Make sure the furniture rests on a flat and level surface with each leg evenly touching the floor.

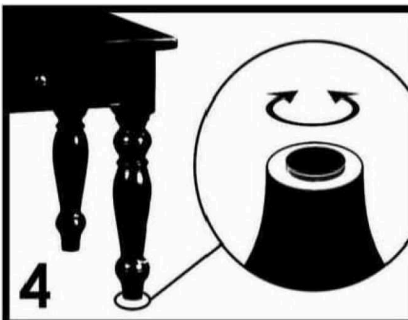

Some furniture comes with height adjustment knobs underneath each leg. To lower or to raise each leg, you need to turn clockwise or counterclockwise, respectively.

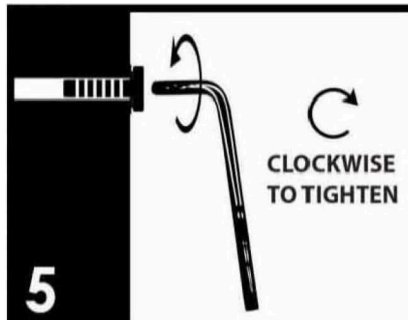

Make sure all parts are properly aligned, then use the appropriate hand tool to completely tighten the bolts or screws. Do not use power tools and do not overtighten.



Save the instructions and store the Allen wrench or any supplied tool for later maintenance. After two weeks, check and tighten any loose hardware and repeat again every six months thereafter.

IT IS THE USER'S RESPONSIBILITY TO MAINTAIN THE FURNITURE. THE HARDWARE MAY LOOSEN OVER TIME AND MAY CAUSE THE FURNITURE TO BE WOBBLY AND UNABLE TO SUPPORT ITS INTENDED WEIGHT CAPACITY. THIS MAY LEAD TO COLLAPSE AND MAY CAUSE SERIOUS INJURY.

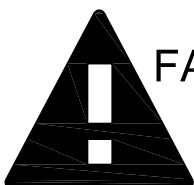

FAILURE TO FOLLOW THE GUIDELINES ABOVE MAY RESULT IN INJURY AND/OR PROPERTY DAMAGE.

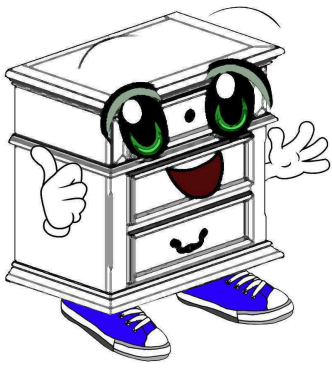

Before you begin, please read Page 2 of "Assembly and Care Advice".

And remember, do not tighten until each step is completed or instructed.

Parts List



#1 x 1pc
Headboard

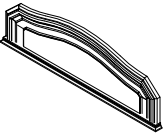

#2 x 1pc
Footboard

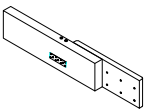

#3 x 2pcs
Headboard Leg(L/R)

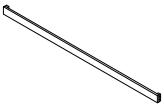

#4 x 1pc
Headboard Support

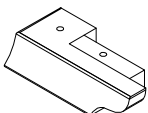

#5 x 2pcs
Footboard Leg(L/R)



#6 x 2pcs
Side Rail



#7 x 4pcs
Slat

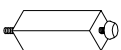

#8 x 8pcs Ø1/4
Support Leg 35x35x200mm

Hardware List



#A x 16pcs
Bolt Ø1/4"x1-3/4"



#B x 4pcs
Bolt Ø1/4"x2"

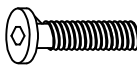

#C x 12pcs
Bolt Ø5/16"x1"



#D x 20pcs
Lock Washer Ø1/4"



#E x 20pcs
Flat Washer Ø1/4"x13



#F x 1pc
Allen Wrench M4

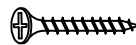

#G x 8pcs
Long Screw #4x30

Exploded View

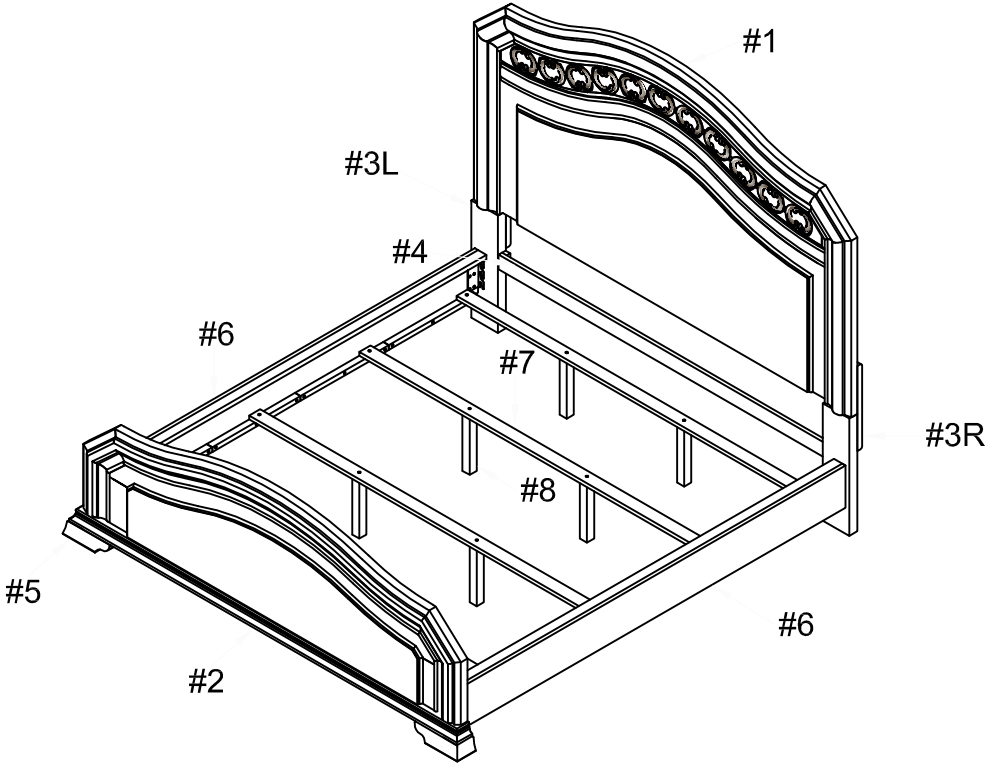

Prepare 12 bolts assembly by inserting lock washer (#D), then flat washer (#E) onto bolts (#A). Align HB legs (#3R/L) to the holes of the headboard (#1). Secure by using bolts (#A).

- #A x 12 pcs
- #D x 12 pcs
- #E x 12 pcs

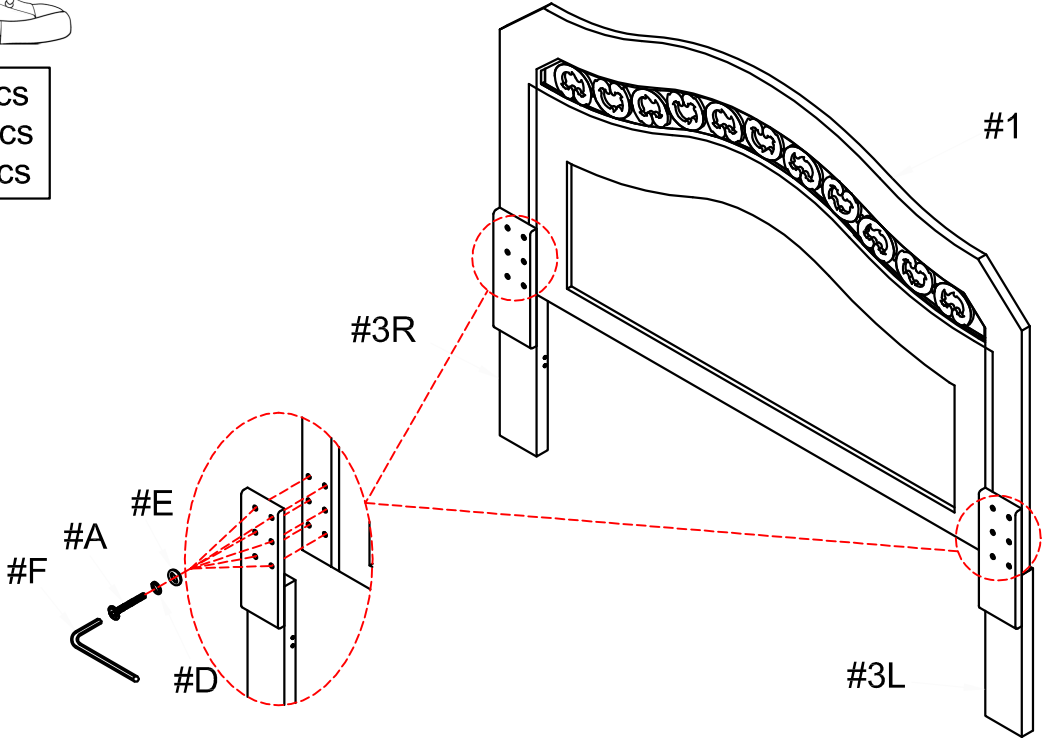



Prepare 4 bolts assembly by inserting lock washer (#D), then flat washer (#E) onto bolts (#A). Align headboard support (#4) to the holes of the headboard legs (#3R/L), then secure by using bolts (#A).

- #A x 4 pcs
- #D x 4 pcs
- #E x 4 pcs

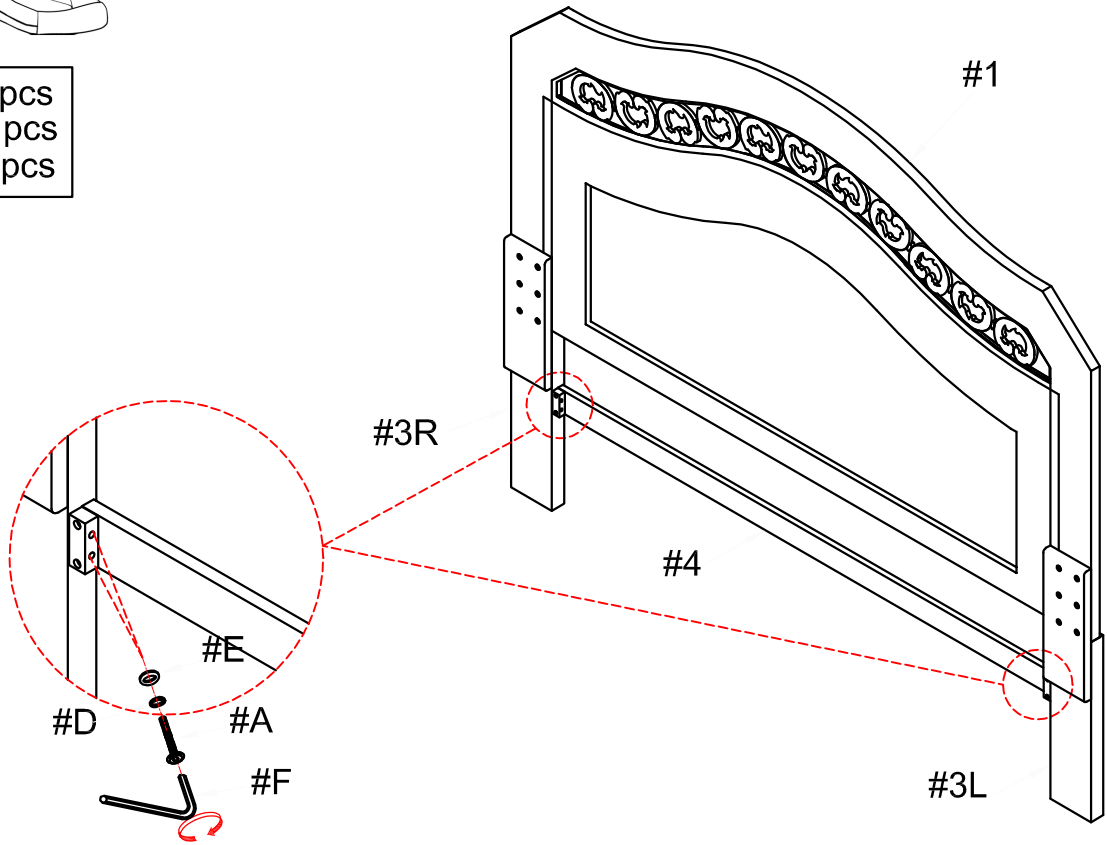

Prepare 4 bolts assembly by inserting lock washer (#D), then flat washer (#E) onto bolts (#B). Align legs (#5R/L) to the holes of the footboard (#2). Secure by using bolts (#B).

- #B x 4 pcs
- #D x 4 pcs
- #E x 4 pcs

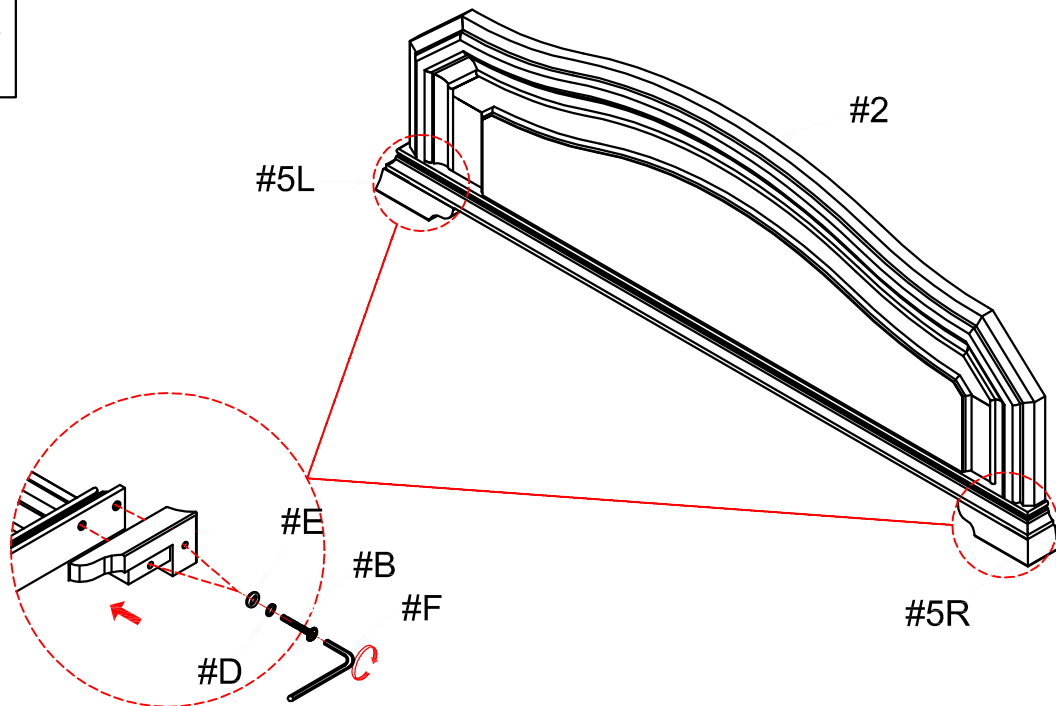



#4

#C x 12 pcs

Attach bolts (#C) half way into the holes of the headboard (#1) and footboard (#2). Align and hook side rails (#6) to the bolts (#C). Secure by tightening bolts (#C).

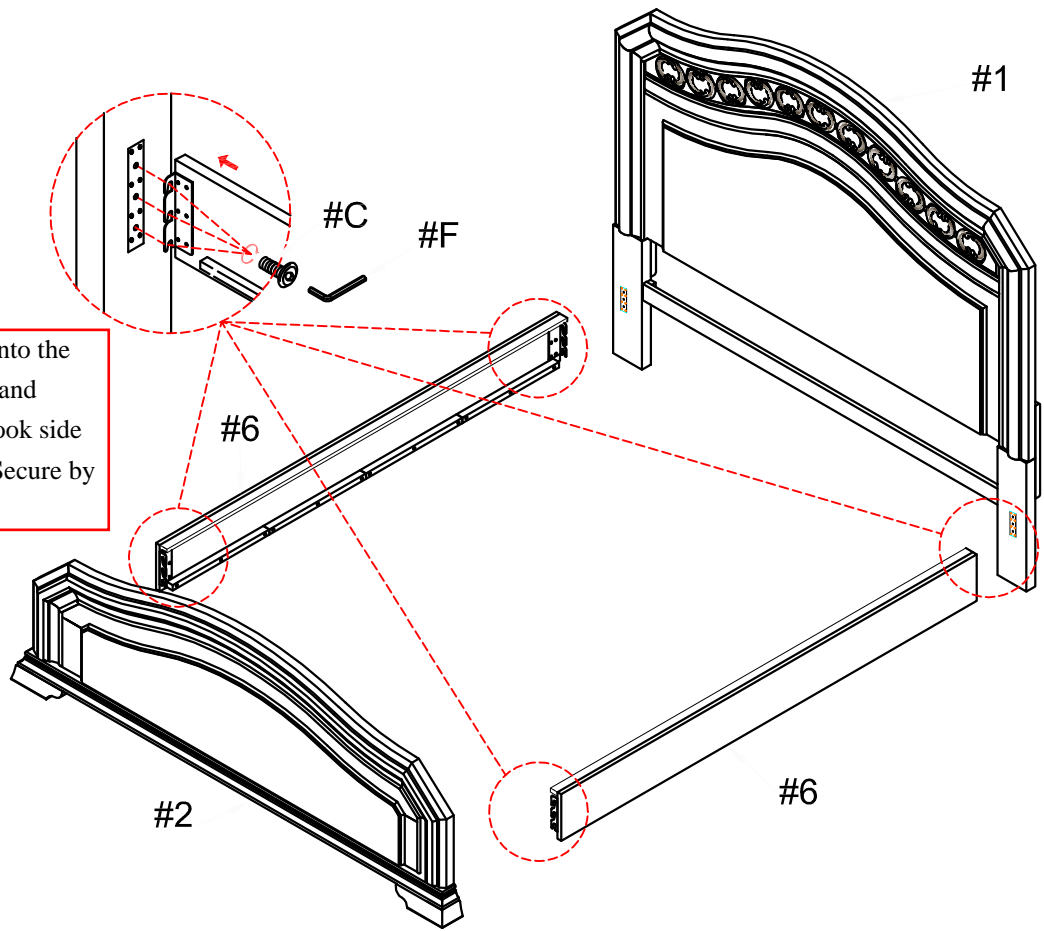

#5

Attach support legs (#8) to the holes of the slats (#7), then adjust the leveler on the support legs (#8) according to ground level.

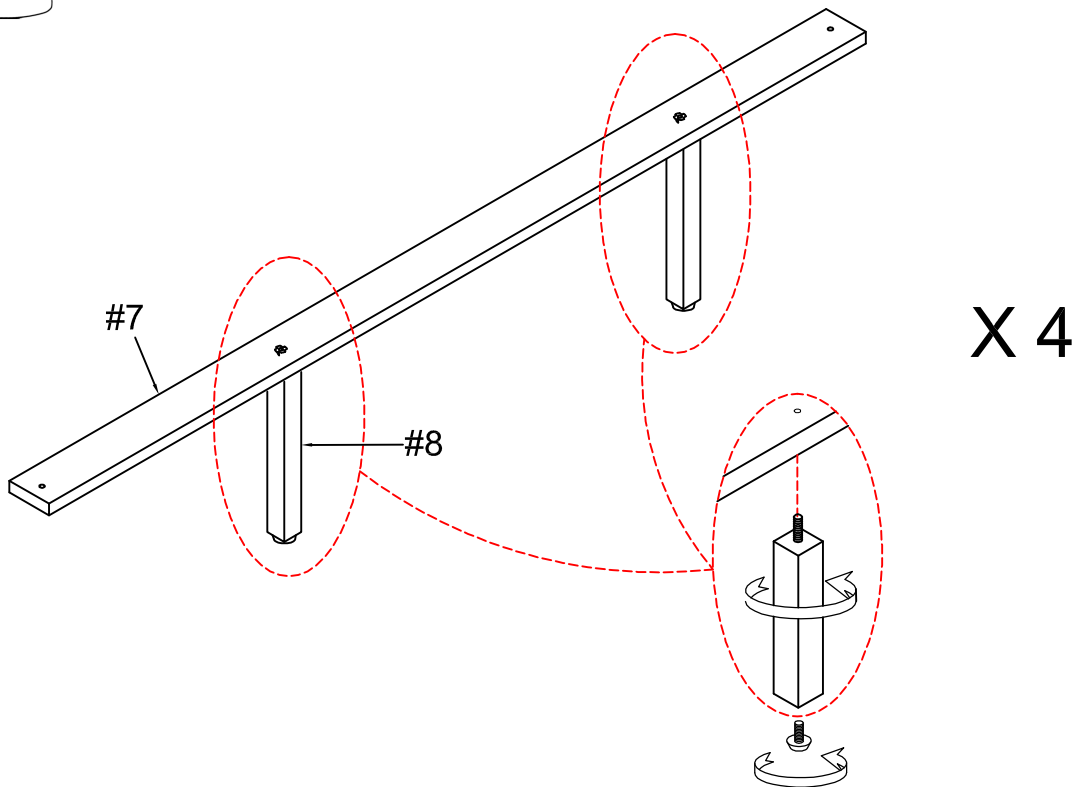



#G x 8 pcs

Align slats to the side rails, secure by using screws (#G).

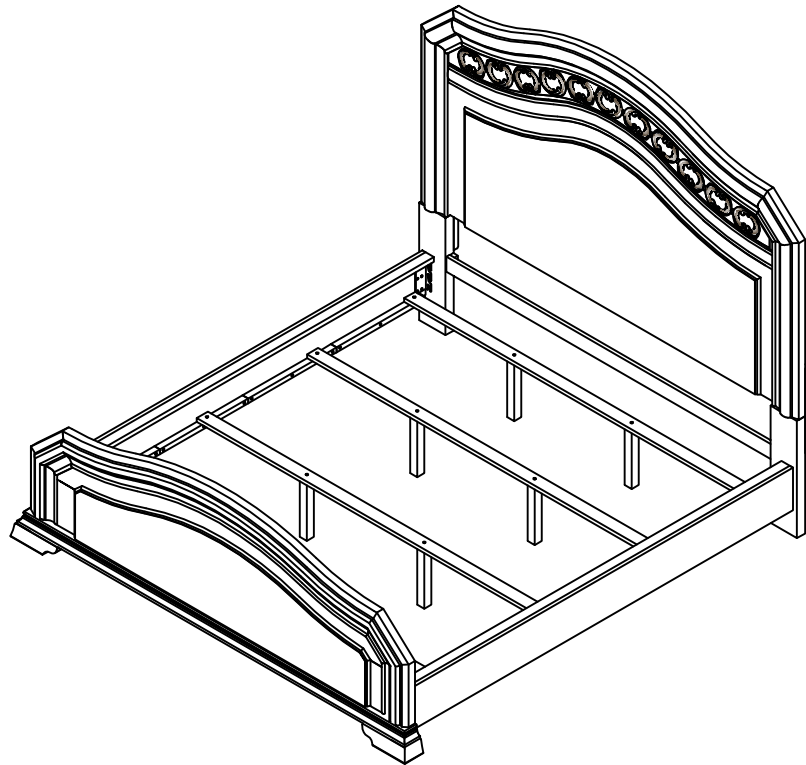
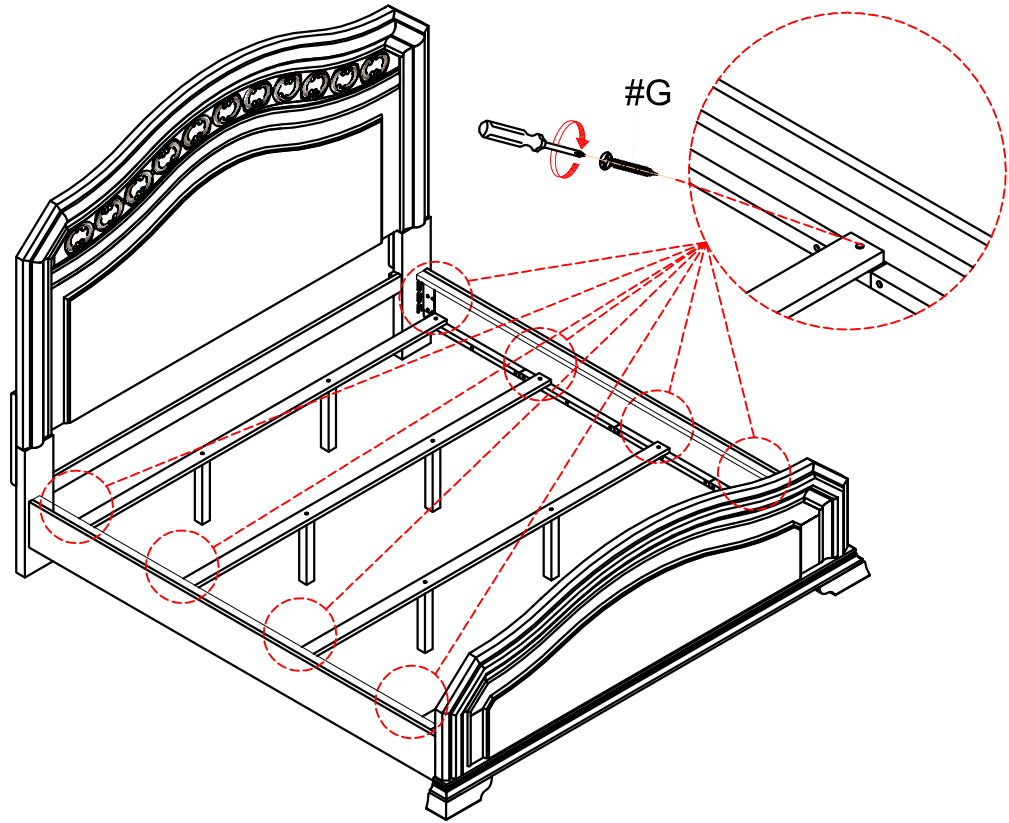

ASSEMBLY IS COMPLETED

Assembly Instructions

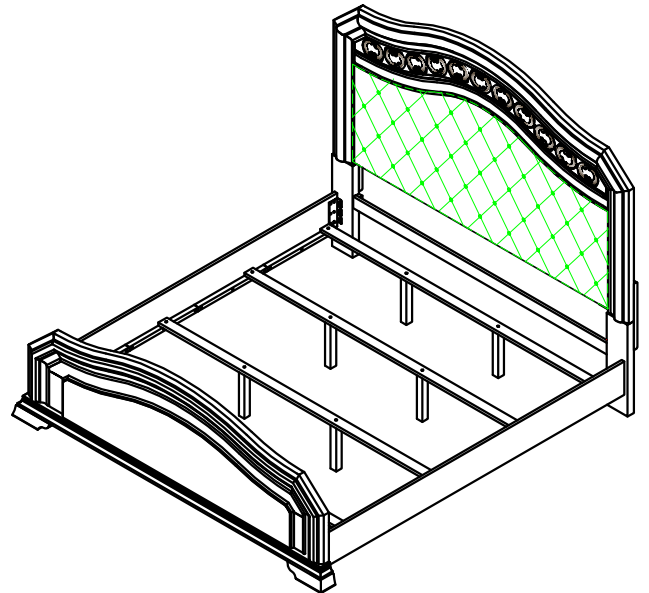
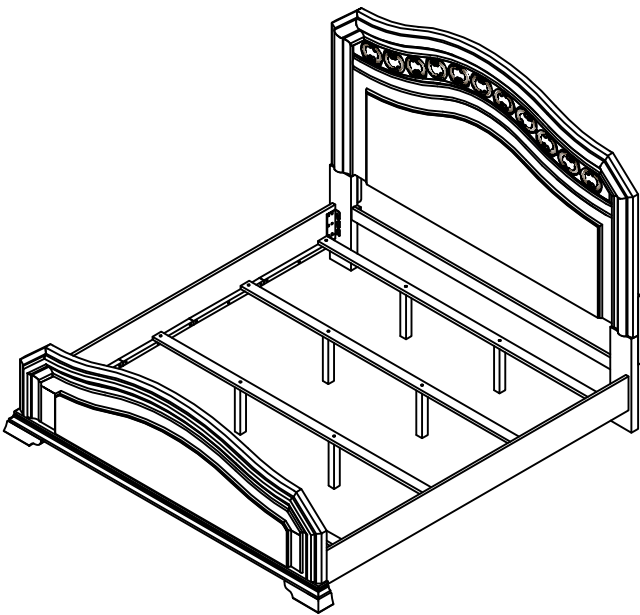

ASSEMBLY RATING

The Assembly Rating is a 5-point system that shows the degree of effort needed in assembling a specific product (with 1 being easy and 5 being difficult). For some products, two persons are recommended.

EASY  DIFFICULT

Tools Required For Assembly:

Allen Wrench

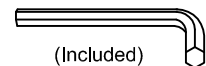

(Included)

Phillips Screwdriver



(Not Included)

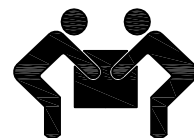

2 PERSONS RECOMMENDED

ASSEMBLY & CARE ADVICE

FOR YOUR FURNITURE TO LAST, CORRECT ASSEMBLY AND PROPER MAINTENANCE ARE NECESSARY. PLEASE FOLLOW THE INFORMATION PROVIDED BELOW TO FULLY ENJOY YOUR FURNITURE.

BASIC ASSEMBLY TECHNIQUES

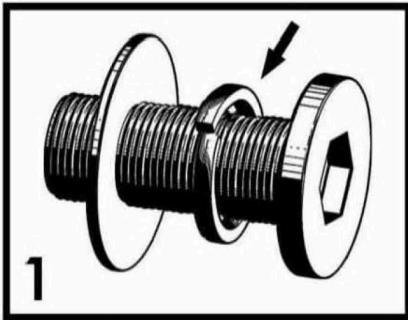

When lock or spring washer is used in an assembly, please make sure the lock or spring washer is placed between the larger flat washer and the head of the screw or bolt.

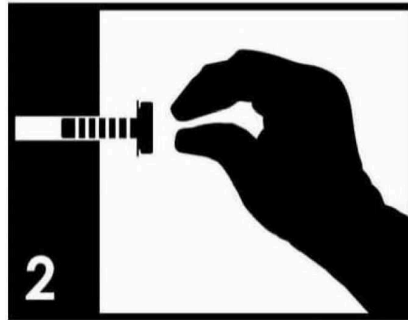

Position each part correctly and insert screws or bolts into their respective holes by hand tighten or using the proper hand tool. Only tighten when step is completed or when instructed to do so.

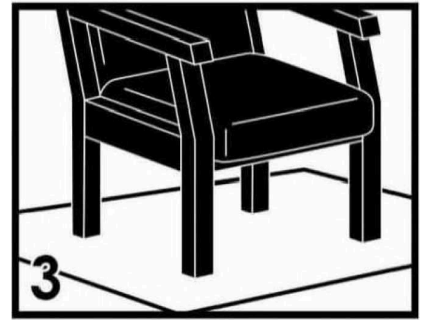

Use cardboard or carpet area when assembling furniture to prevent scratches. Make sure the furniture rests on a flat and level surface with each leg evenly touching the floor.

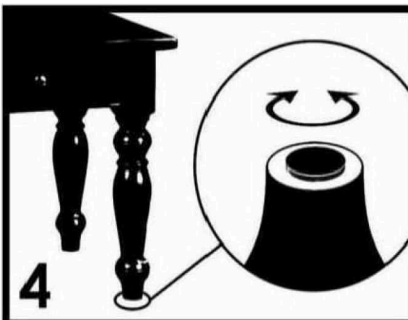

Some furniture comes with height adjustment knobs underneath each leg. To lower or to raise each leg, you need to turn clockwise or counterclockwise, respectively.

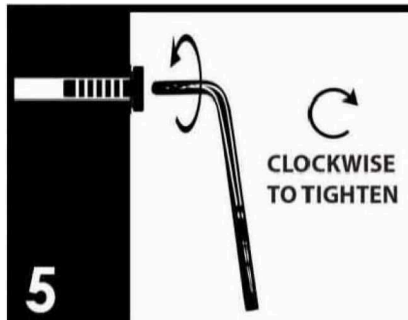

Make sure all parts are properly aligned, then use the appropriate hand tool to completely tighten the bolts or screws. Do not use power tools and do not overtighten.

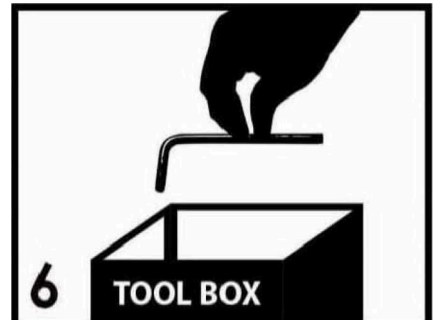

Save the instructions and store the Allen wrench or any supplied tool for later maintenance. After two weeks, check and tighten any loose hardware and repeat again every six months thereafter.

IT IS THE USER'S RESPONSIBILITY TO MAINTAIN THE FURNITURE. THE HARDWARE MAY LOOSEN OVER TIME AND MAY CAUSE THE FURNITURE TO BE WOBBLY AND UNABLE TO SUPPORT ITS INTENDED WEIGHT CAPACITY. THIS MAY LEAD TO COLLAPSE AND MAY CAUSE SERIOUS INJURY.

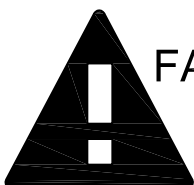

FAILURE TO FOLLOW THE GUIDELINES ABOVE MAY RESULT IN INJURY AND/OR PROPERTY DAMAGE.

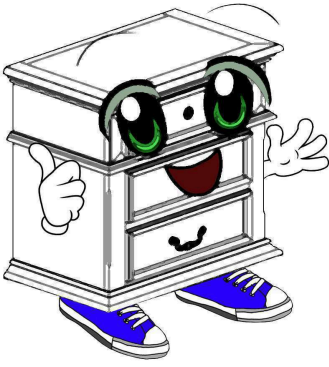

Before you begin, please read Page 2 of "Assembly and Care Advice".

And remember, do not tighten until each step is completed or instructed.

Parts List



#1 x 1pc
Headboard

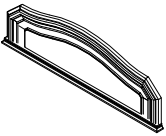

#2 x 1pc
Footboard

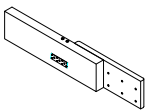

#3 x 2pcs
Headboard Leg(L/R)

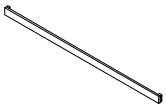

#4 x 1pc
Headboard Support

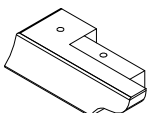

#5 x 2pcs
Footboard Leg(L/R)



#6 x 2pcs
Side Rail



#7 x 4pcs
Slat

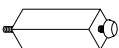

#8 x 8pcs Ø1/4
Support Leg 35x35x200mm

Hardware List



#A x 16pcs
Bolt Ø1/4"x1-3/4"



#B x 4pcs
Bolt Ø1/4"x2"

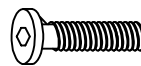

#C x 12pcs
Bolt Ø5/16"x1"



#D x 20pcs
Lock Washer Ø1/4"



#E x 20pcs
Flat Washer Ø1/4"x13



#F x 1pc
Allen Wrench M4

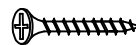

#G x 8pcs
Screw #4x30

Exploded View

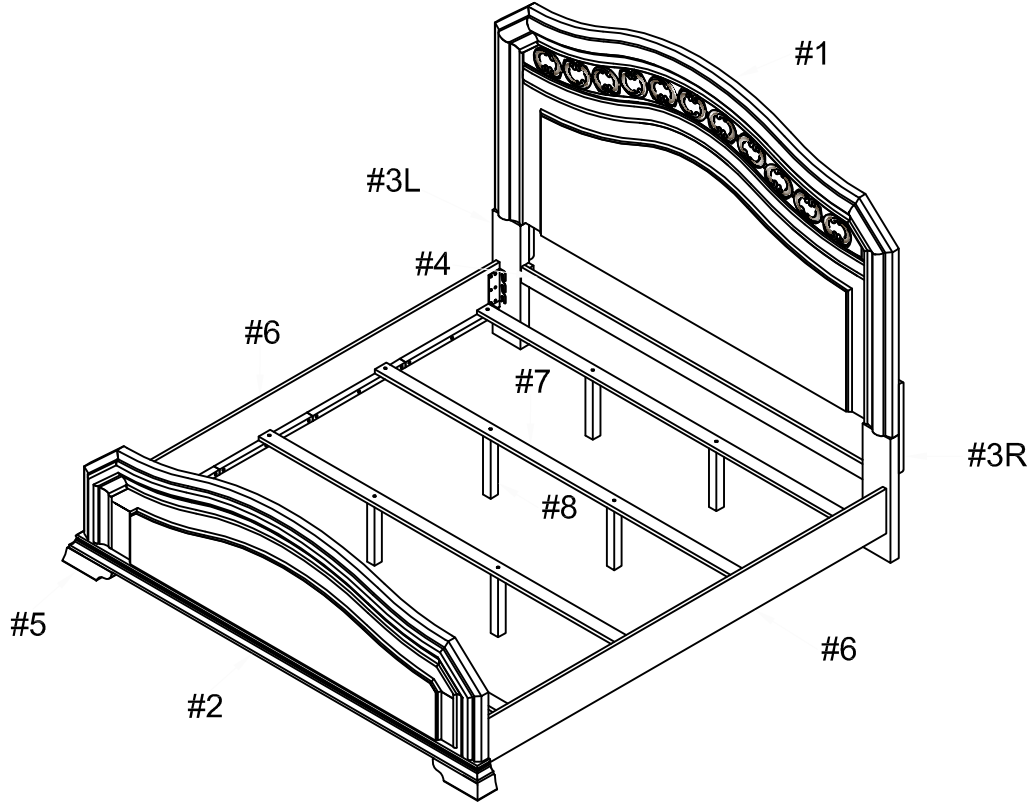

Prepare 12 bolts assembly by inserting lock washer (#D), then flat washer (#E) onto bolts (#A). Align HB legs (#3R/L) to the holes of the headboard (#1). Secure by using bolts (#A).

- #A x 12 pcs
- #D x 12 pcs
- #E x 12 pcs

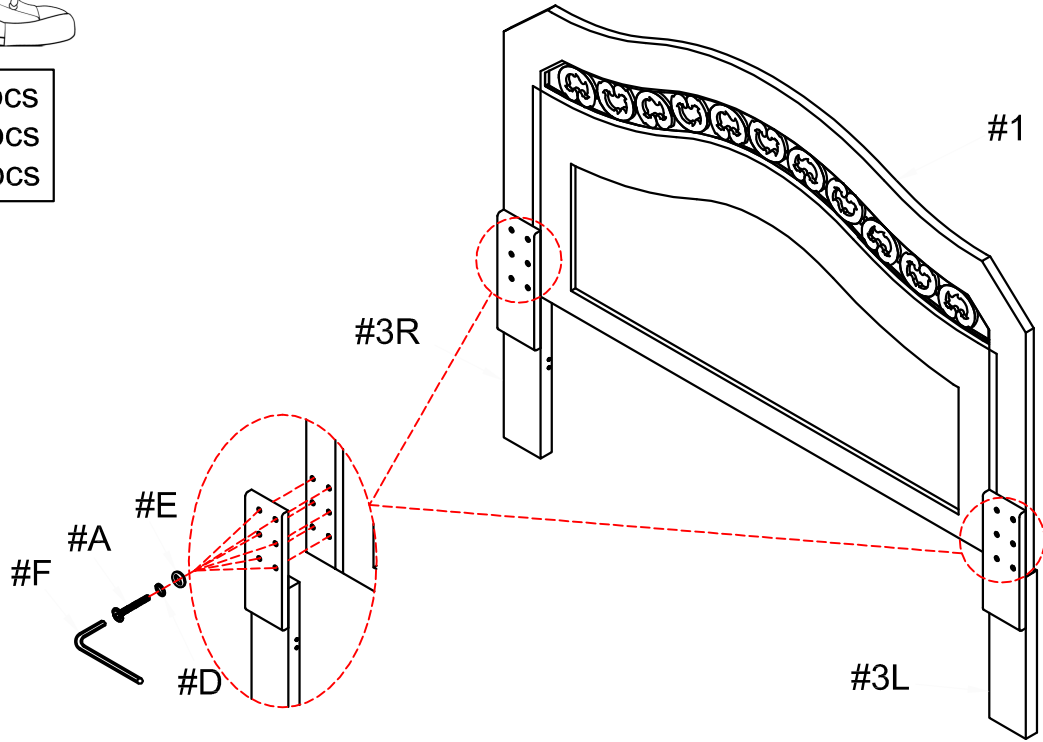



Prepare 4 bolts assembly by inserting lock washer (#D), then flat washer (#E) onto bolts (#A). Align headboard support (#4) to the holes of the headboard legs (#3R/L), then secure by using bolts (#A).

#A x 4 pcs
#D x 4 pcs
#E x 4 pcs

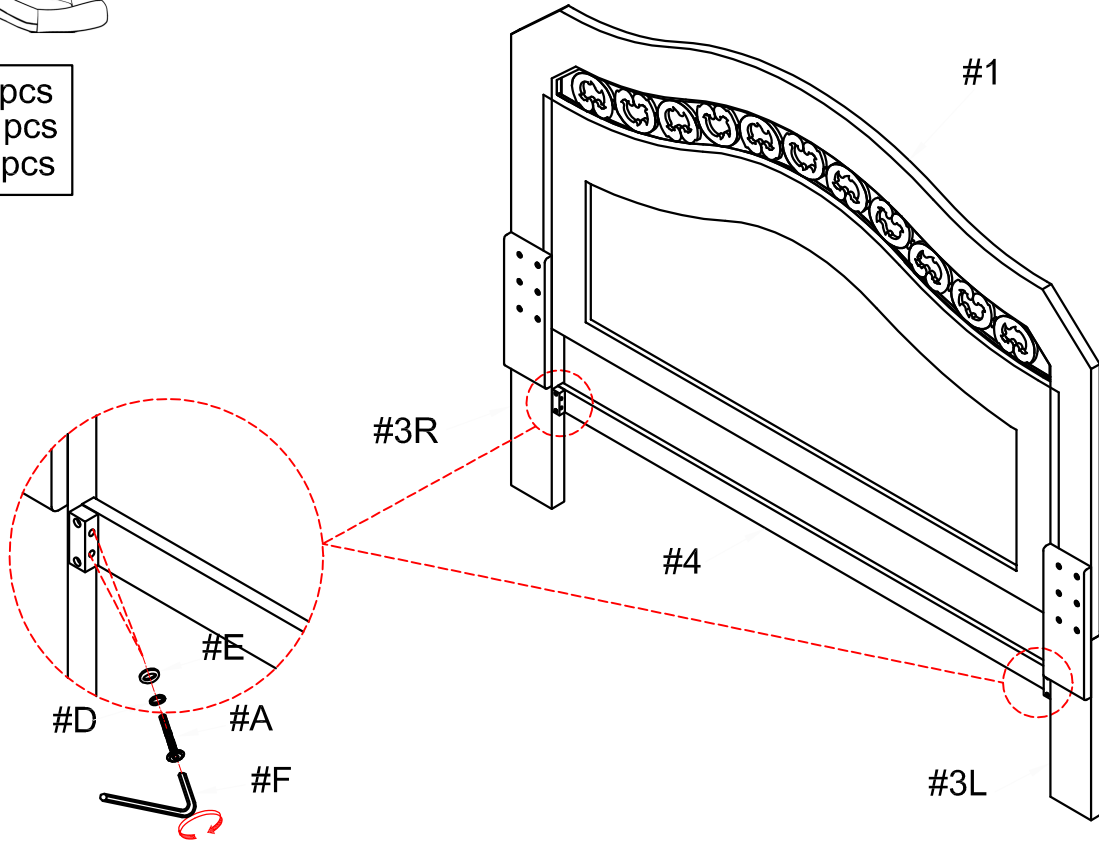

Prepare 4 bolts assembly by inserting lock washer (#D), then flat washer (#E) onto bolts (#B). Align legs (#5R/L) to the holes of the footboard (#2). Secure by using bolts (#B).

#B x 4 pcs
#D x 4 pcs
#E x 4 pcs

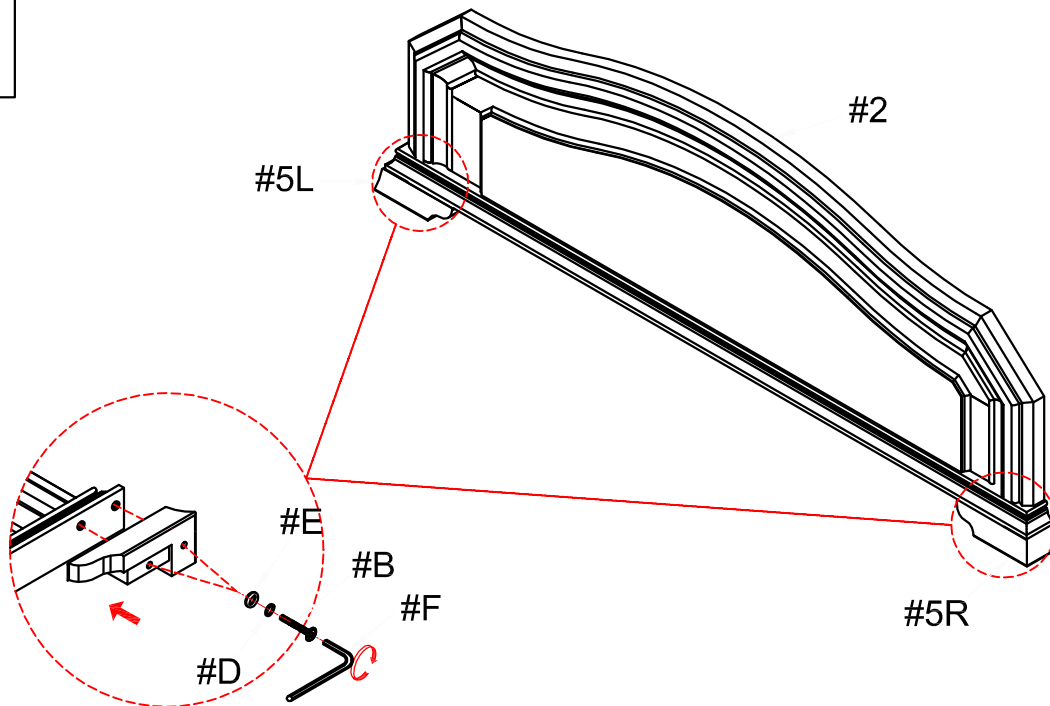



#4

#C x 12 pcs

Attach bolts (#C) half way into the holes of the headboard (#1) and footboard (#2). Align and hook side rails (#6) to the bolts (#C). Secure by tightening bolts (#C).

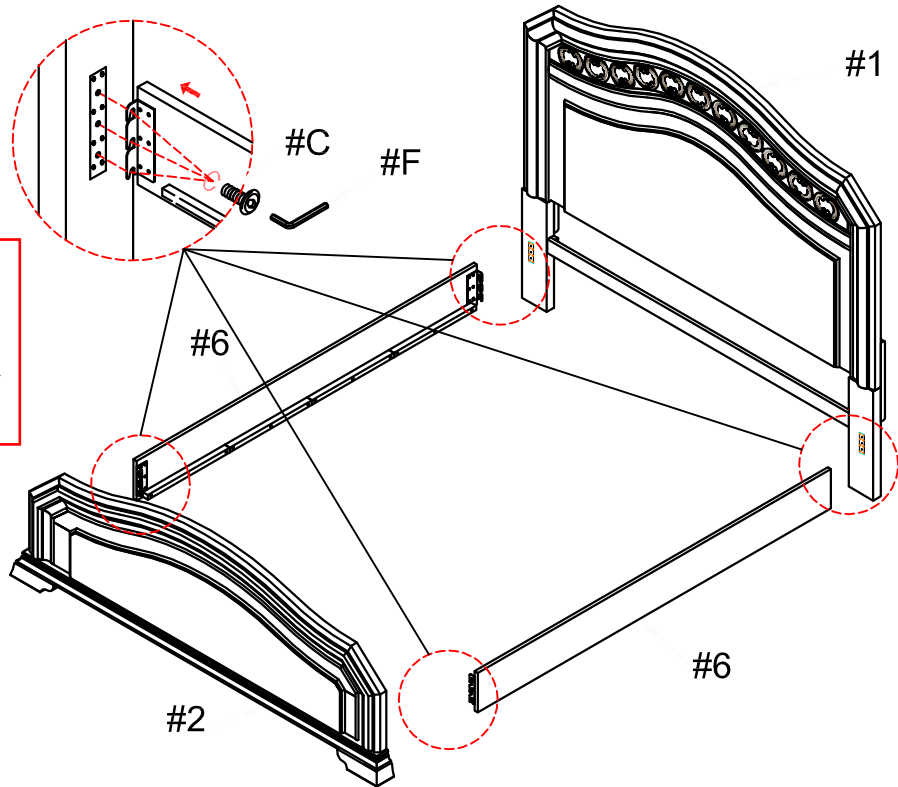

#5

Attach support legs (#8) to the holes of the slats (#7), then adjust the leveler on the support legs (#8) according to ground level.

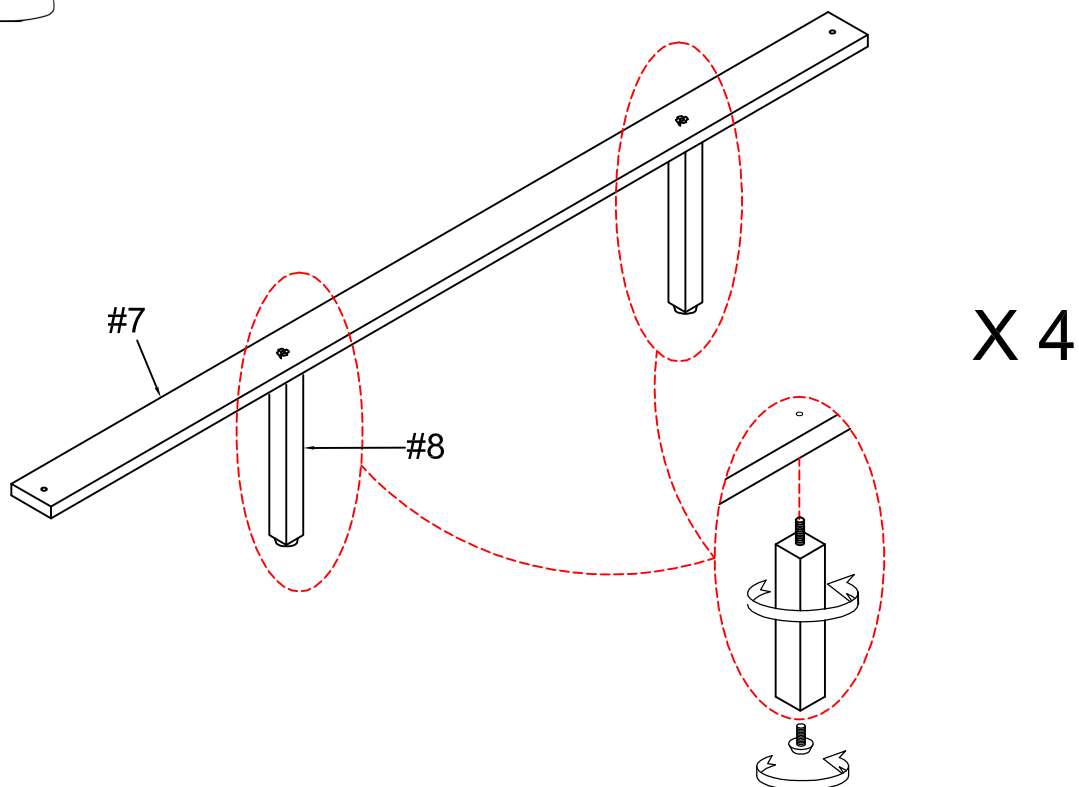



Align slats to the side rails, secure by using screws (#G).

#G x 8 pcs

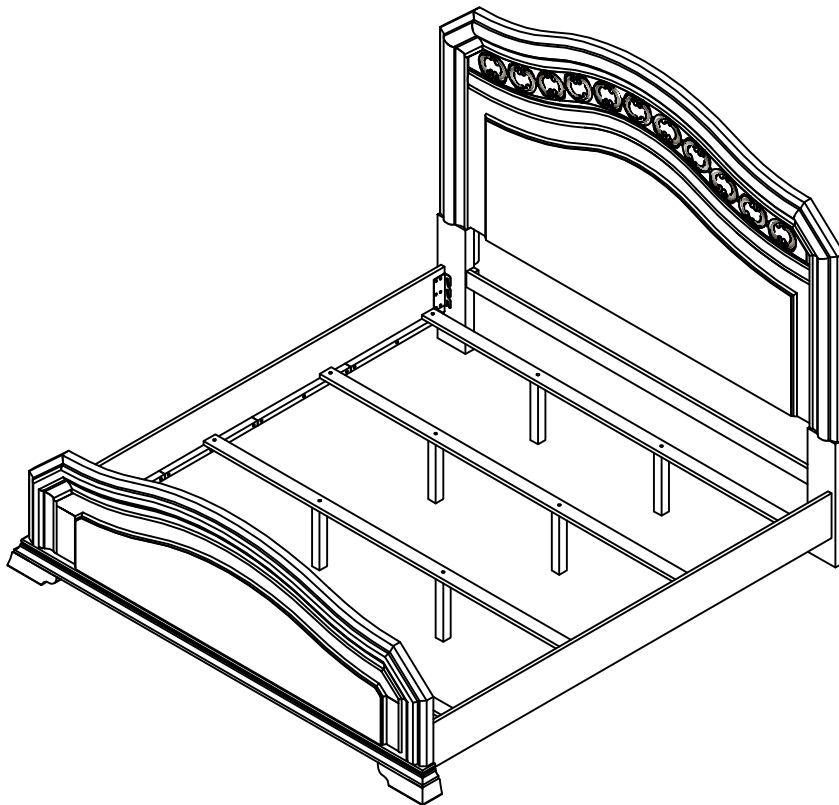
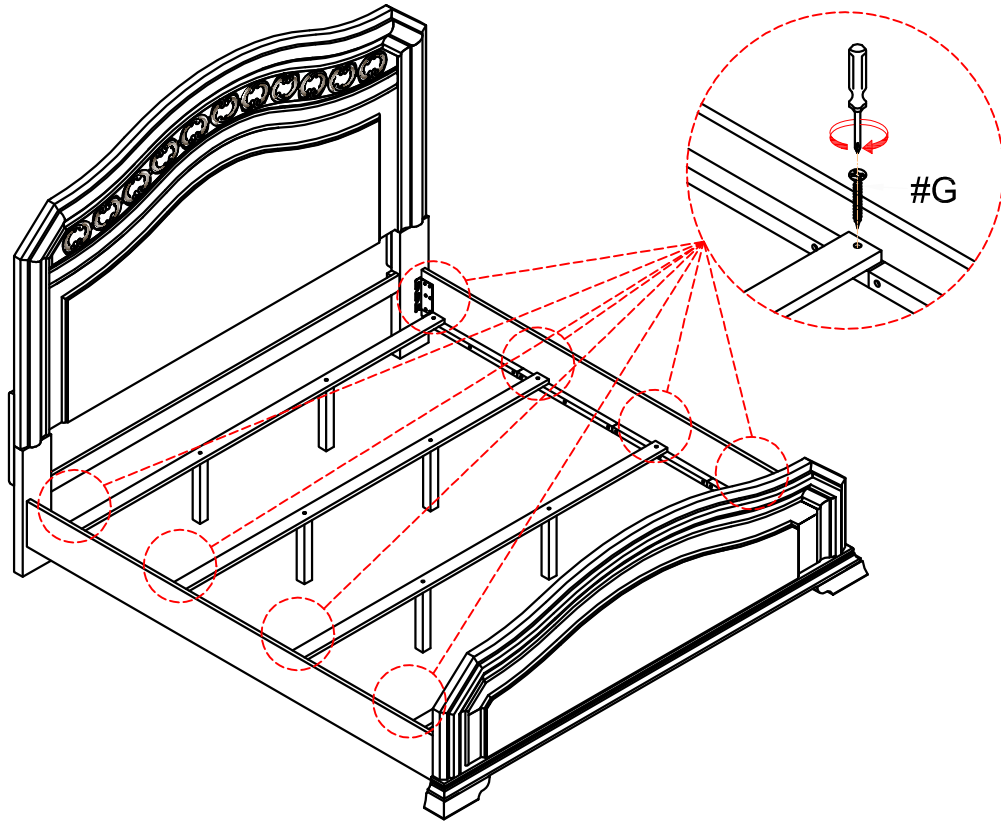

ASSEMBLY IS COMPLETED