



ASSEMBLY INSTRUCTIONS

Winfield Dining Chair



Important safety instructions:

- Please read carefully all instructions before assembling.
- For your safety and ease, assembly by two or more adults is recommended.
- Keep instructions for future use.

Pre-assembly:



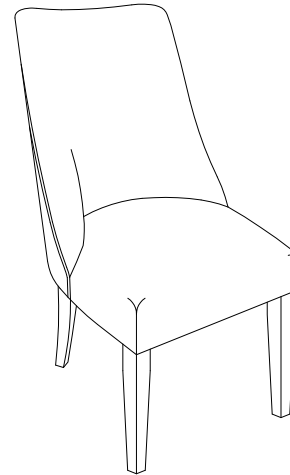

- Do not discard any content until assembly completed to avoid accidentally discarding small parts or hardware.
- Take out all parts and hardwares from box.

Parts List

Item	Description	QTY
P1	Chair Body 	1
P2	Front Leg 	2
P3	Back Leg 	2







Hardware List

Item	Description	QTY
H1	Bolt $\phi 5/16$ "*1-5/8"L 	8
H2	Lock Washer $\phi 5/16$ " 	8
H3	Flat Washer $\phi 5/16$ " 	8
H4	Allen Wrench $\phi 5/16$ " 	1

Assembly Procedures:

Step 1. Assemble the chair on a flat, soft surface such as a carpet or cloth to prevent scratching the finish. Attach the front legs (P2) and back legs (P3) to the bottom of chair body (P1) as shown below image 1.

- (H1)x8 Bolt $\phi 5/16$ "*1-5/8"L 
- (H2)x8 Lock Washer $\phi 5/16$ " 
- (H3)x8 Flat Washer $\phi 5/16$ " 
- (H4)x1 Allen Wrench $\phi 5/16$ " 

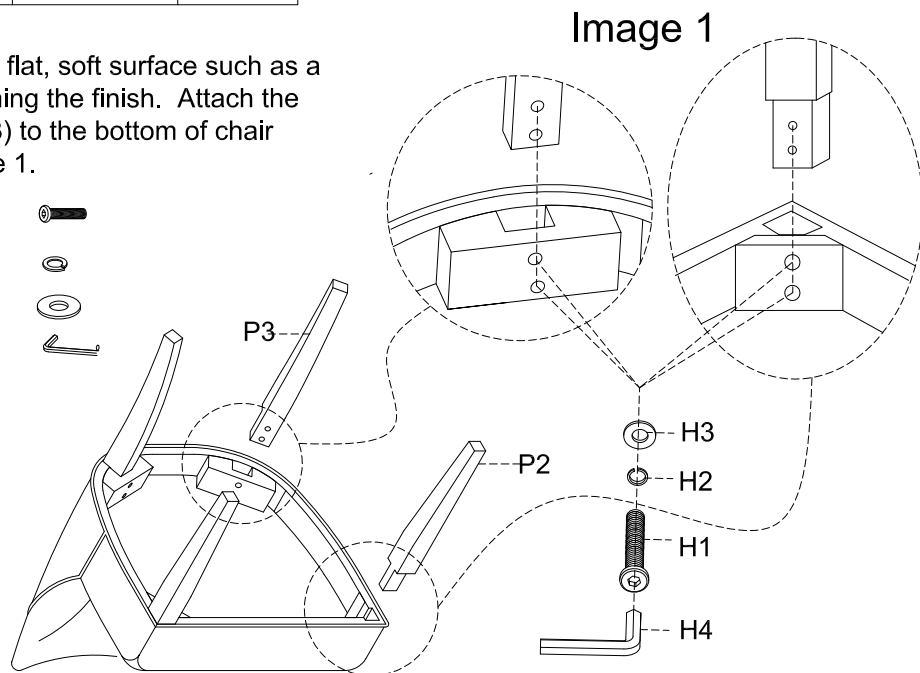

Step 2. Securely tighten all bolts, turn the assembled chair to an upright position. Make sure the chair is leveled and aligned properly, assembly is complete. **Failure to follow these instructions may cause the bolts to misalign during assembly.**

ADDITIONAL NOTE ABOUT SAFETY: BOLTS MAY LOOSEN DURING NORMAL EVERYDAY USE. THEY SHOULD BE PERIODICALLY INSPECTED AND RE-TIGHTENED TO PREVENT DAMAGE OR INJURY. ALWAYS CHECK TO ENSURE THAT ALL HARDWARE IS KEPT TIGHTENED.

Thank you for your purchase