

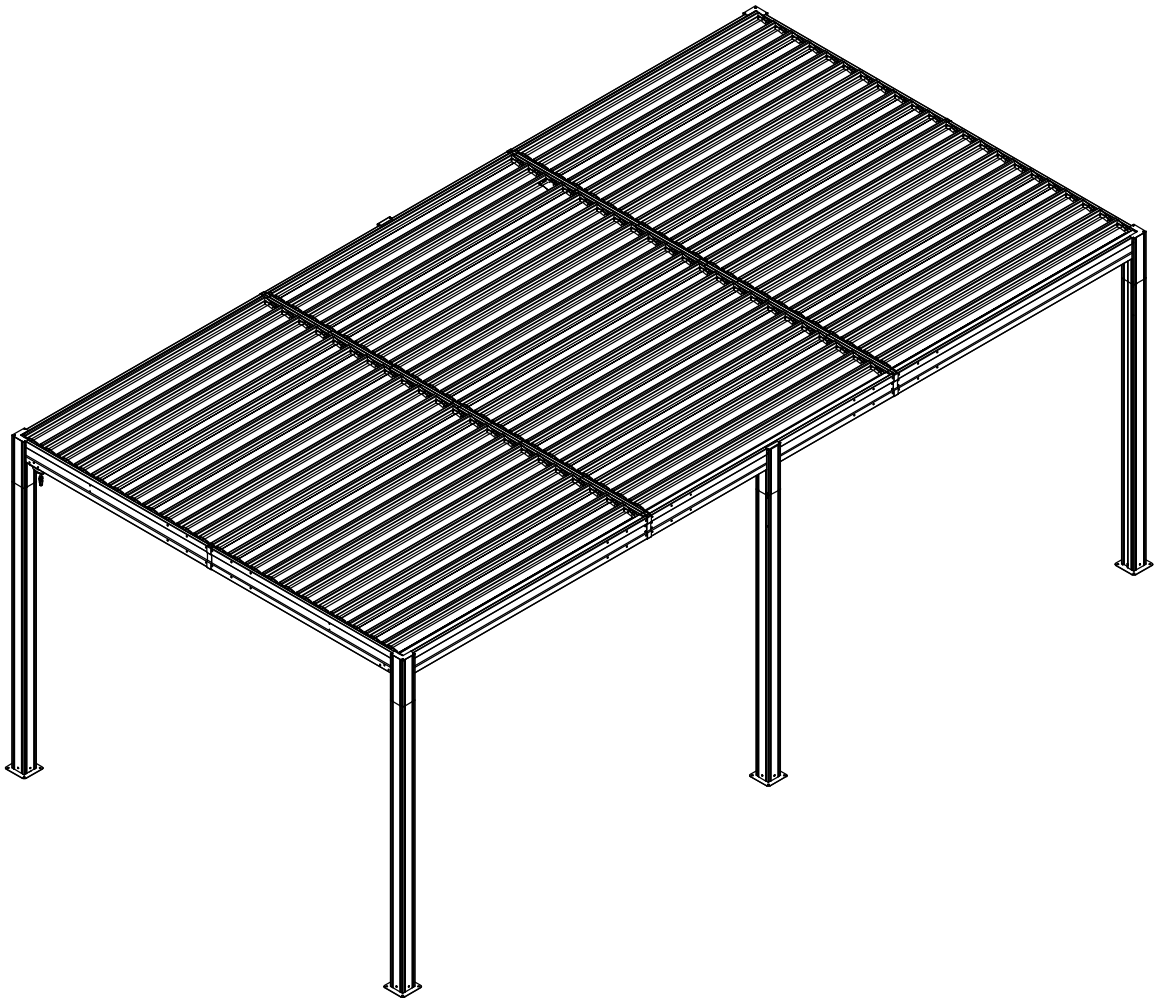

10' × 20' ALUMINUM  
LOUVERED PERGOLA  
**ASSEMBLY MANUAL**



MODEL#: LGCF1764

Missing part? Damaged? Contact us via email at

[service@domioutdoorliving.com](mailto:service@domioutdoorliving.com)

[www.domioutdoorliving.com](http://www.domioutdoorliving.com)

© Copyright 2024-2026 domioutdoorliving LLC. All Rights Reserved.

# READ ALL INSTRUCTIONS BEFORE USE

## Warning & Attention

-This gazebo is not a toy. Children are not allowed to assemble or disassemble. Please take care of children, do not let them play around when assemble or disassemble.

-Adults only for assemble or disassemble this product.

-This product is constructed with heavy duty frame, please do not lean or climb before it finish assembling.

-Even though our hardtop gazebo is sturdy, please do not stand under the gazebo during a lightning storm.

-DO NOT use this gazebo if any parts show signs of instability or damage.

-Maximum weight capacity is 1000 pounds.

-If moderate to heavy snow is forecast, open the lovers to avoid snow accumulating.



Four or more people are needed for assembly.



Find out and use the hex keys in the box.



One or more ladders are necessary.



A phillips screwdriver is required.



Please wear protective glove before assembly.



Please don't fully tighten the screws prior to complete assembly.



Please wear a safety hat.



You may need prepare a drill.

# 10'x20' Louvered Pergola Dimension

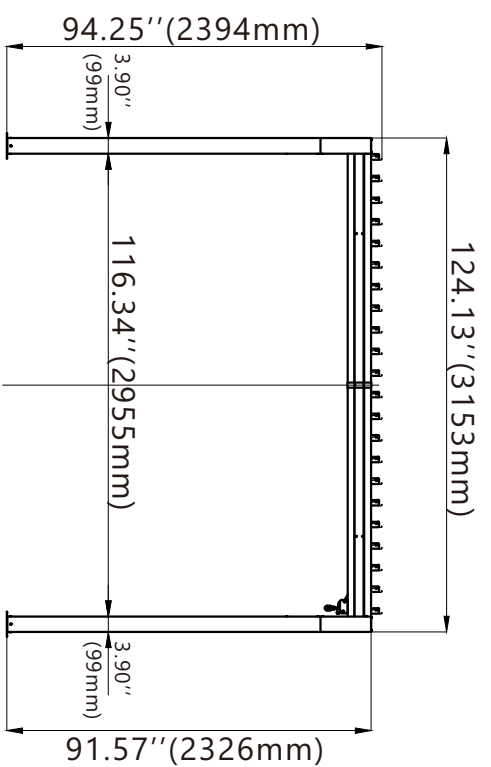
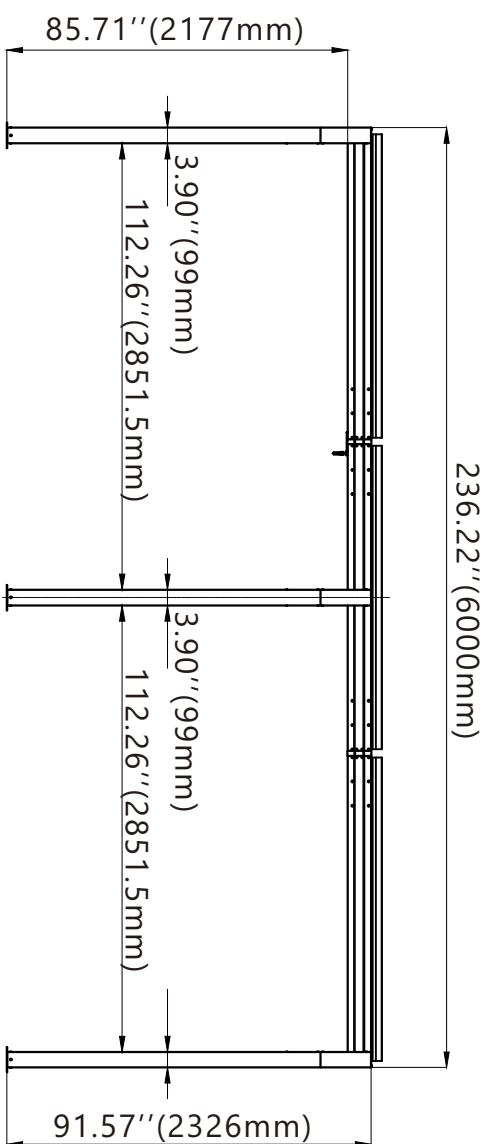
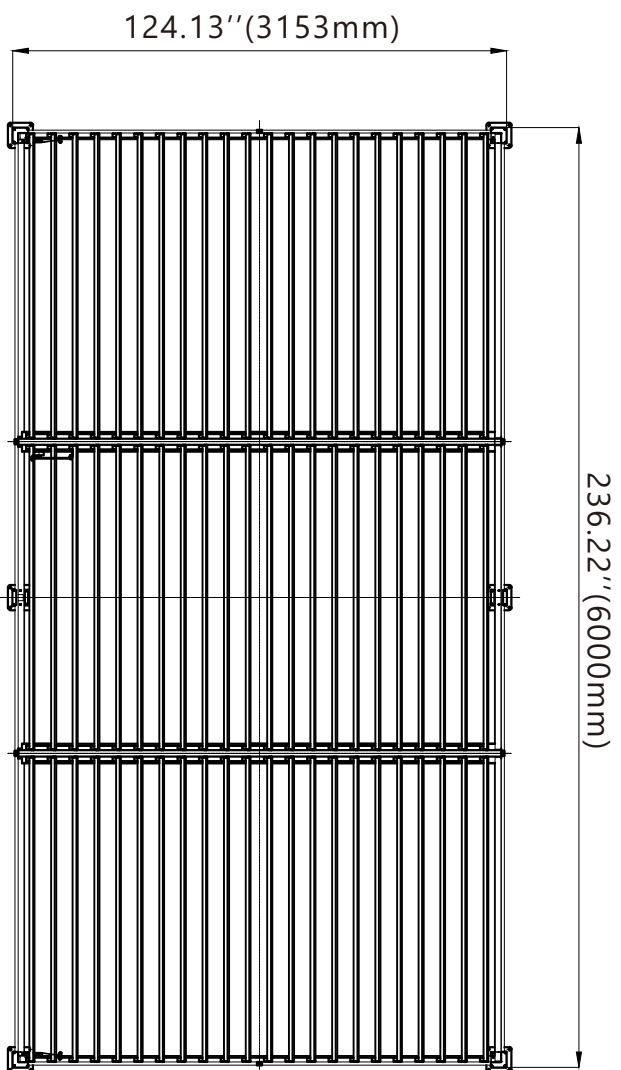

**LGCF1764**  
**10'x20'**

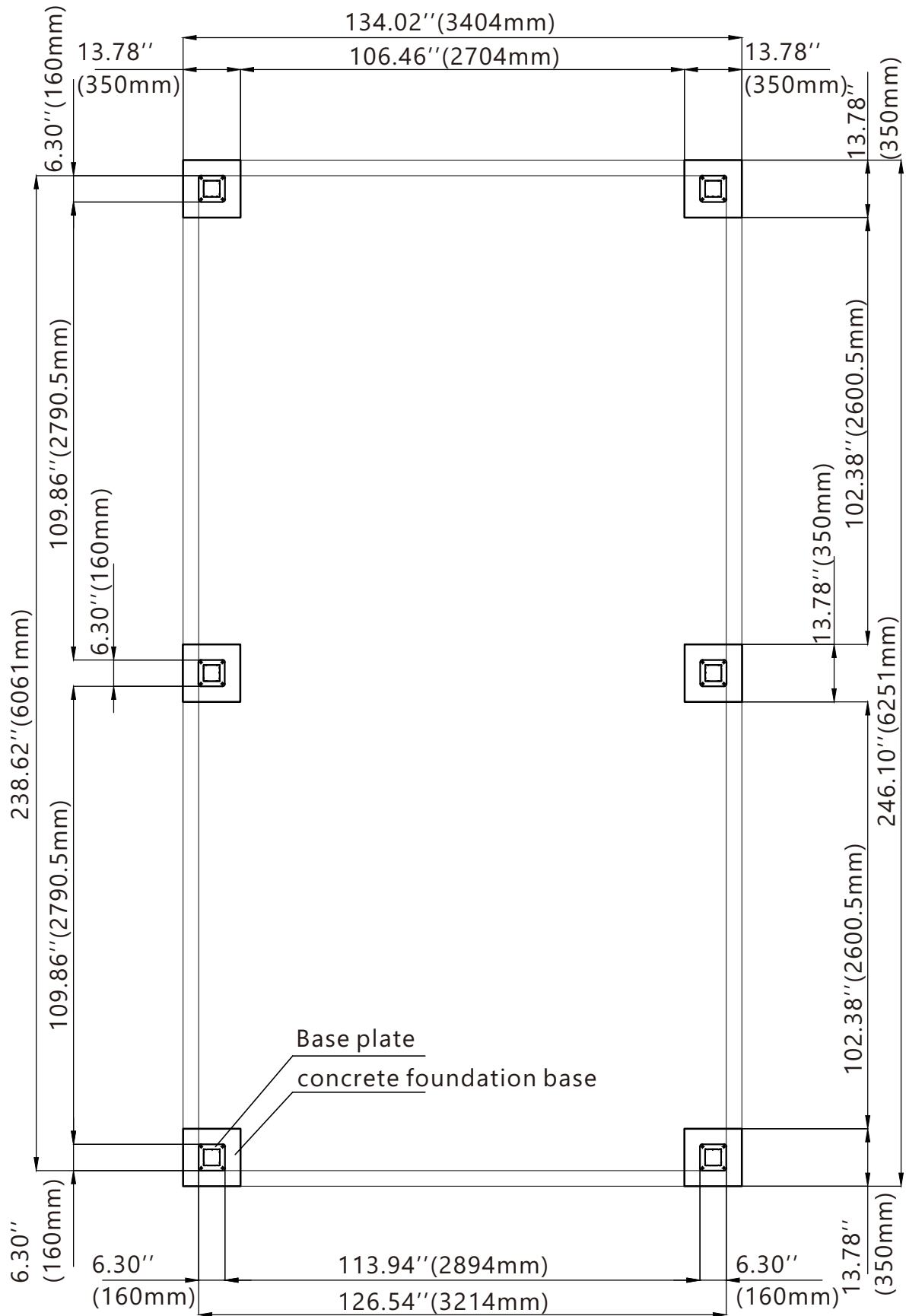

## Foundation Mounting Drawing

1764 (10X20) – Foundation Mounting Drawing

This warranty does not cover products subject to inappropriate installation. Caution: The base plate of the pergola must be mounted on a concrete foundation with a thickness of over 3 inches using expansion bolts. DO NOT substitute expansion bolts with ordinary screws.

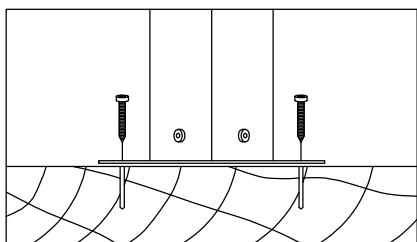
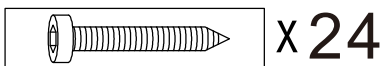



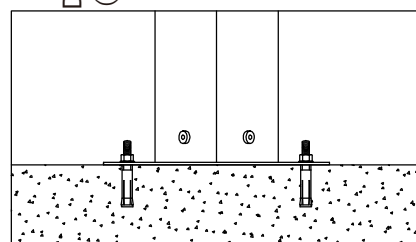
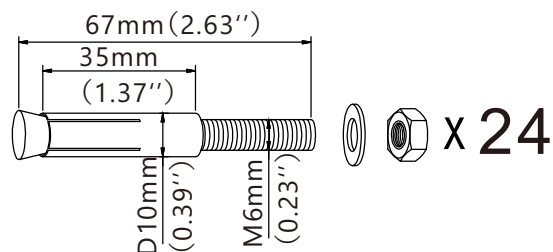
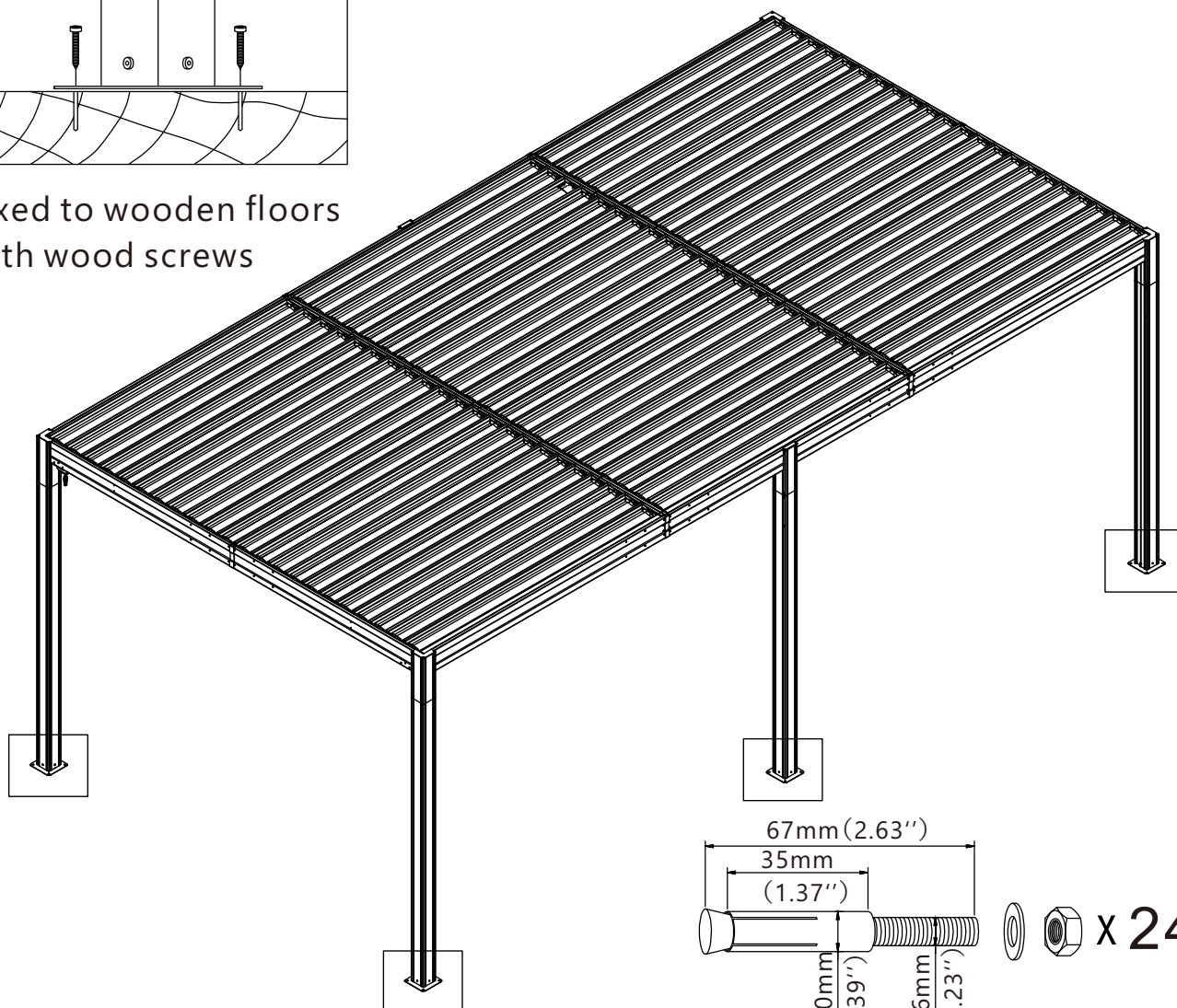



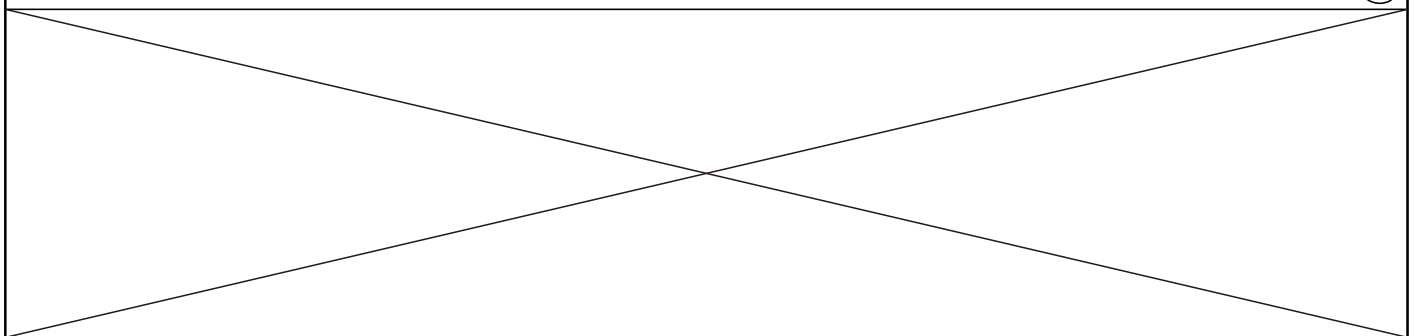
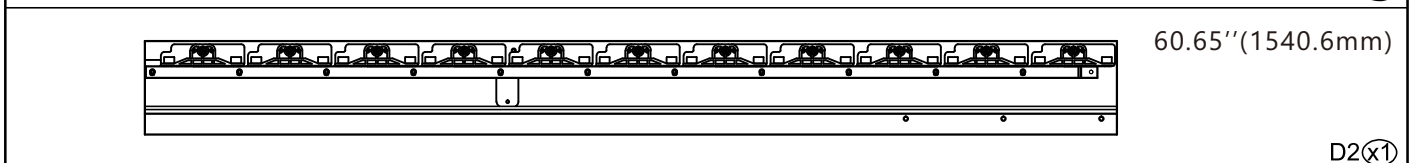
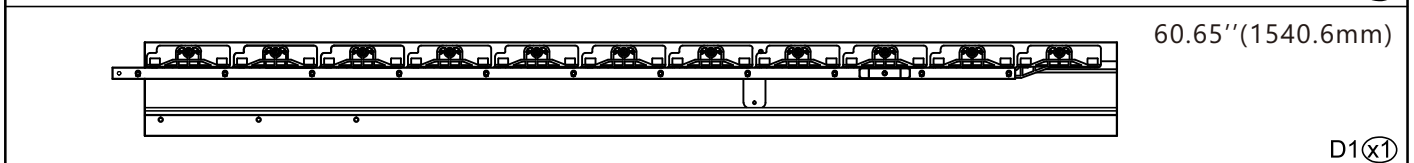
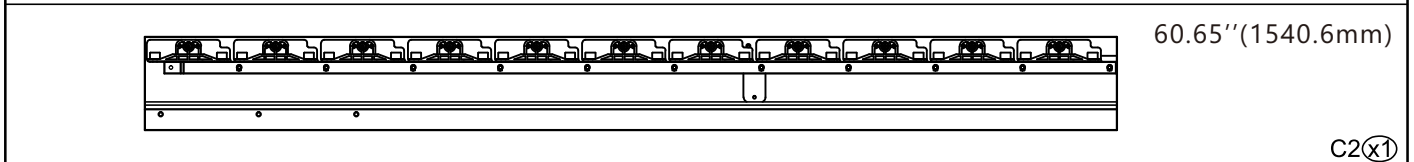
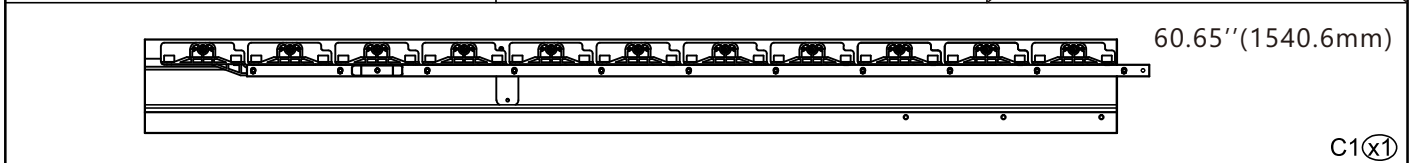
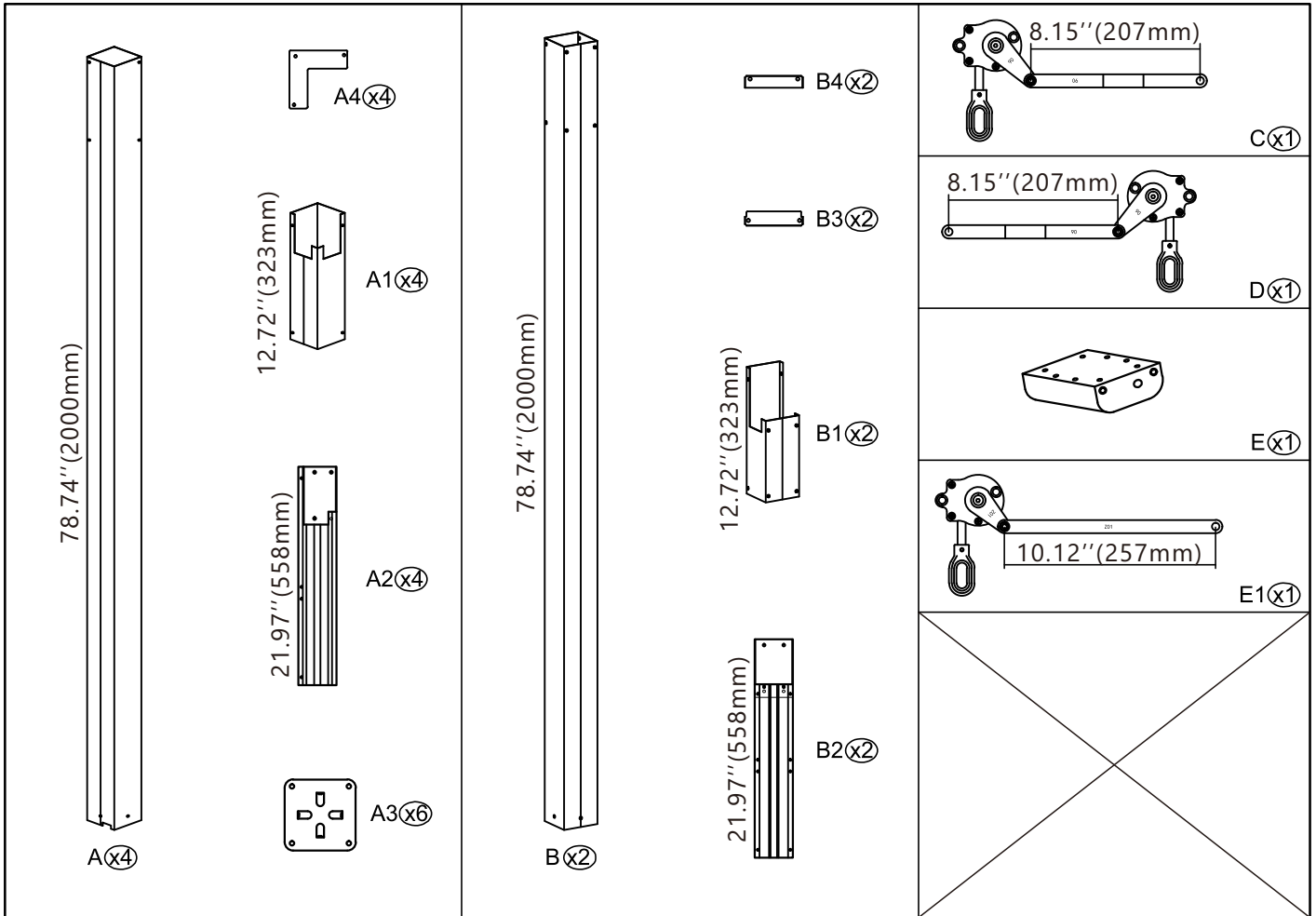

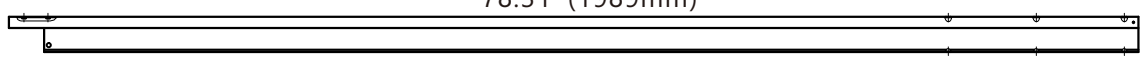

Fixed to wooden floors with wood screws

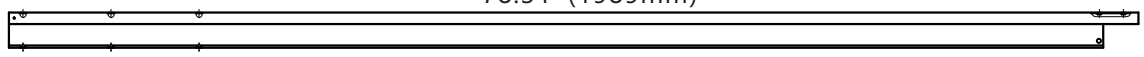

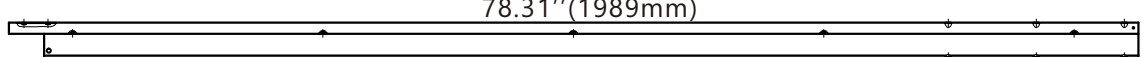
Fixed to concrete foundations with expansion tube screws

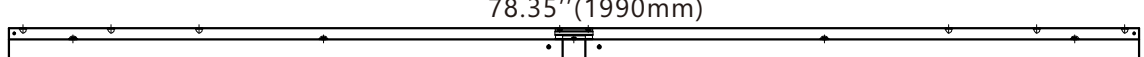

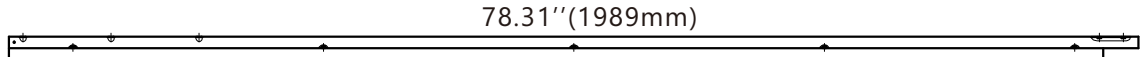
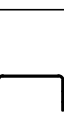
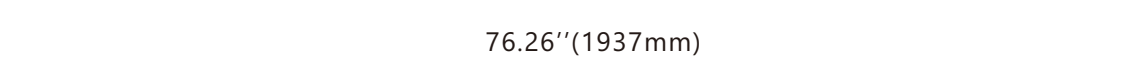
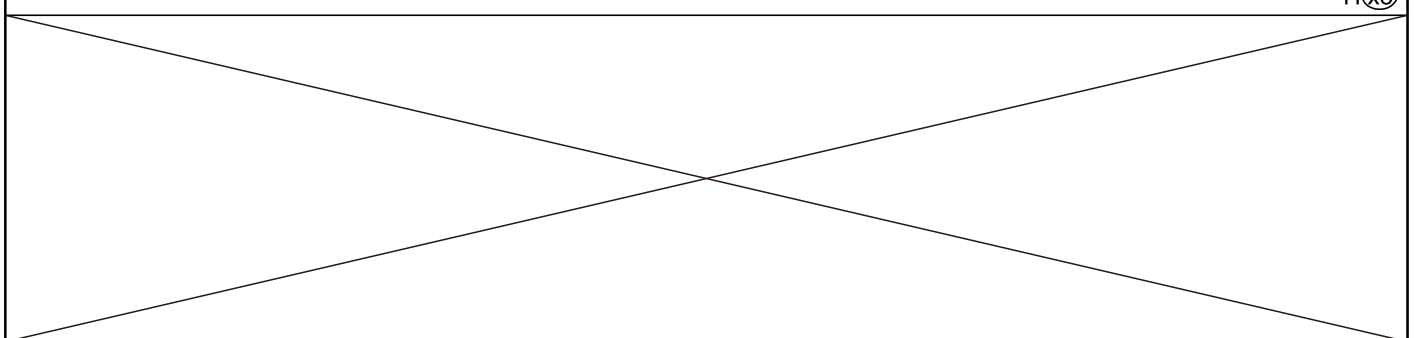
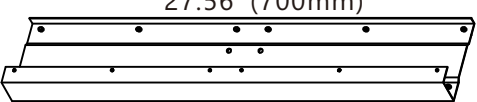
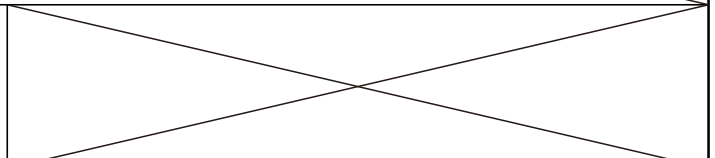
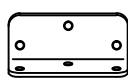
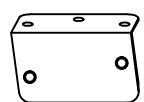
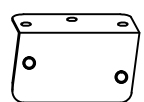
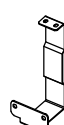
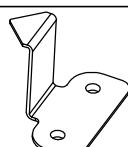
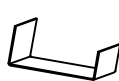
	 <p>78.31''(1989mm)</p>	<p>F1(x1)</p>
	 <p>78.35''(1990mm)</p>	<p>F2(x1)</p>
	 <p>78.31''(1989mm)</p>	<p>F3(x1)</p>
	 <p>78.31''(1989mm)</p>	<p>G1(x1)</p>
	 <p>78.35''(1990mm)</p>	<p>G2(x1)</p>
	 <p>78.31''(1989mm)</p>	<p>G3(x1)</p>
	 <p>76.26''(1937mm)</p>	<p>H(x3)</p>
		
 <p>27.56''(700mm)</p>		
 <p>K(x2)</p>	 <p>K1(x1)</p>	 <p>K2(x1)</p>
 <p>L(x6)</p>	 <p>L1(x4)</p>	 <p>U(x4)</p>

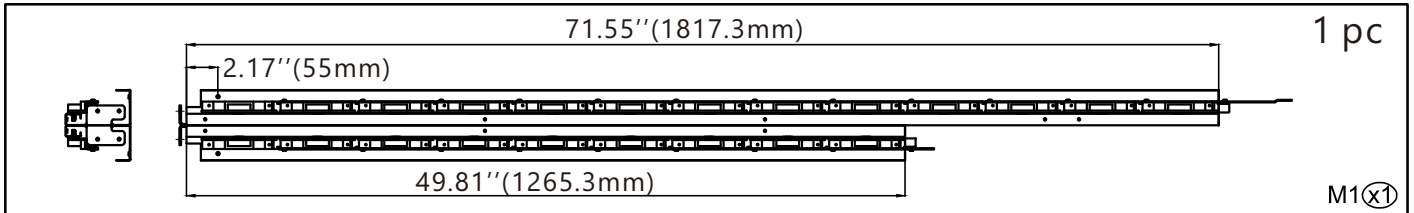

1 pc

M1(x1)

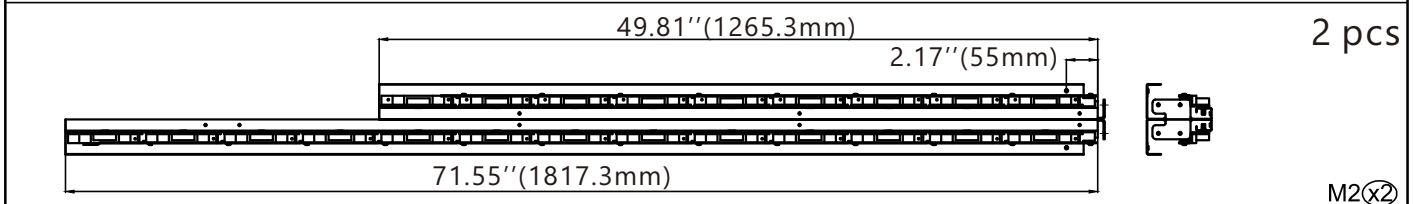

2 pcs

M2(x2)

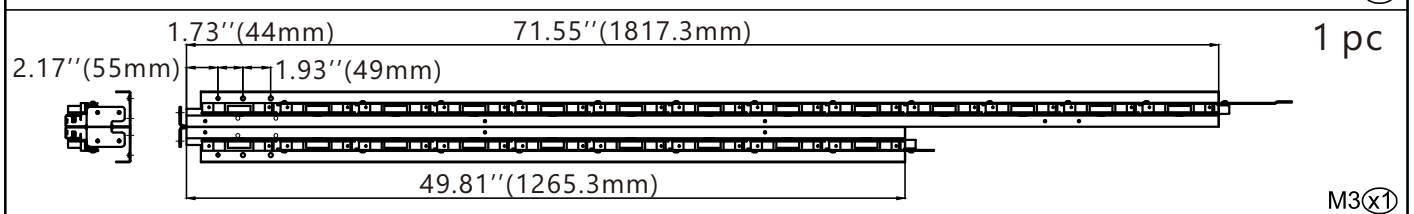

1 pc

M3(x1)

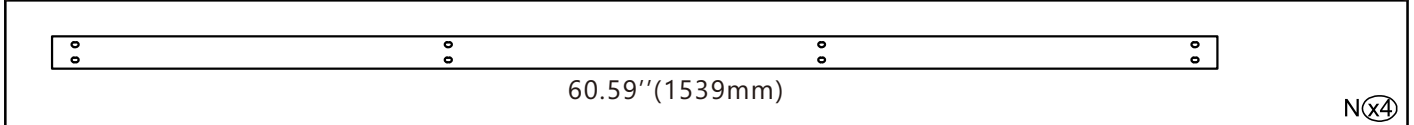
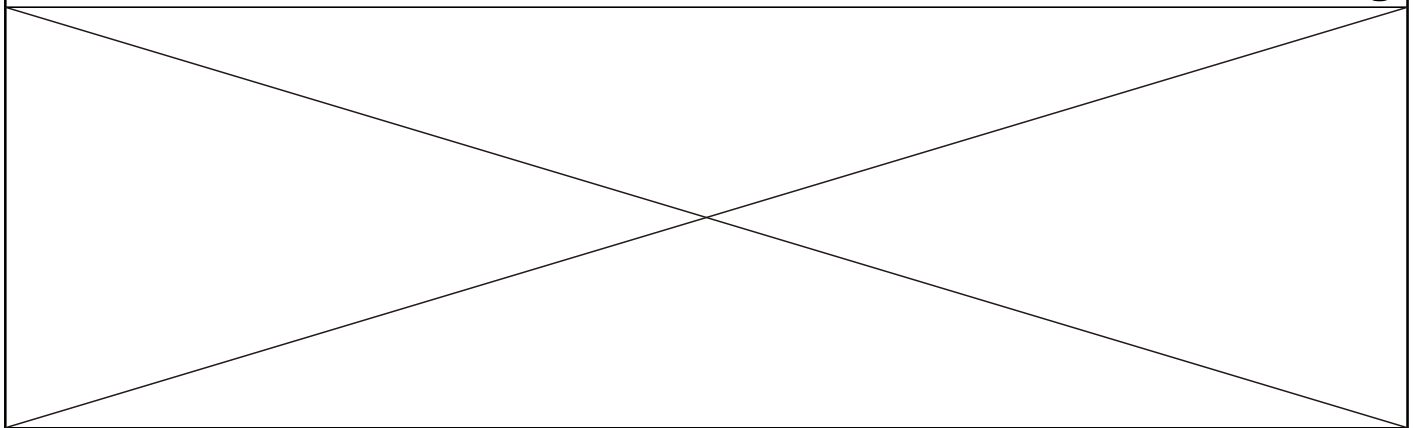

N(x4)

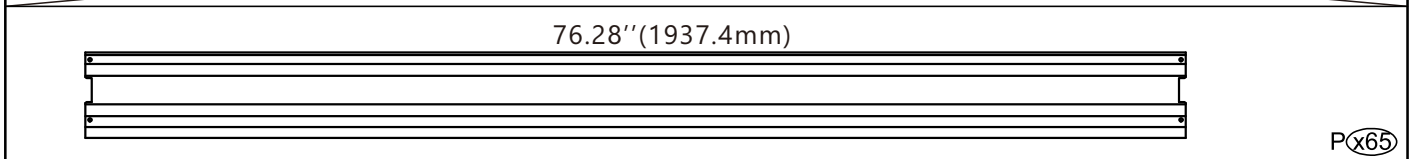
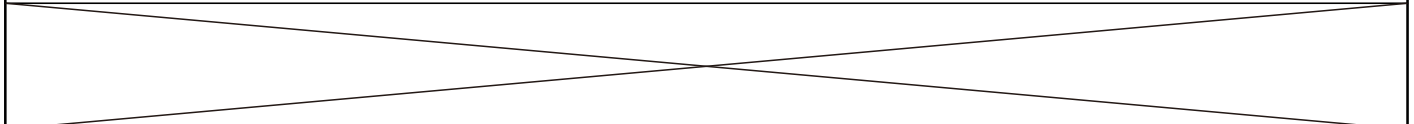



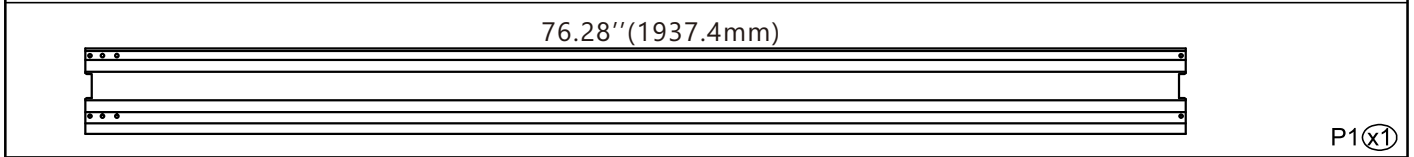



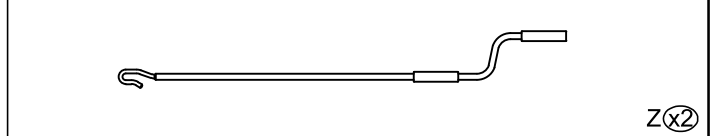
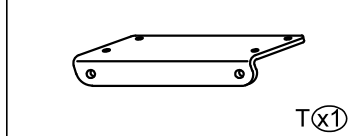
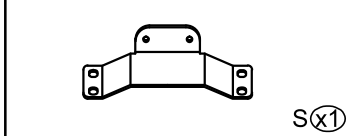
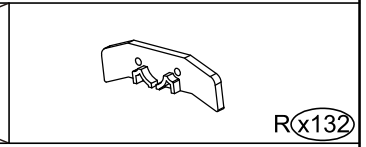
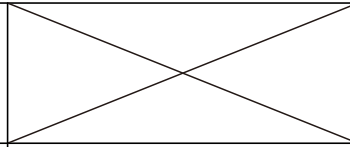
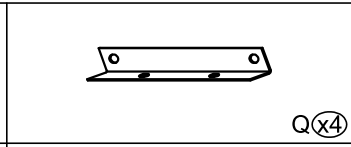
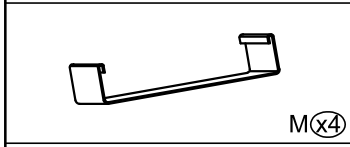
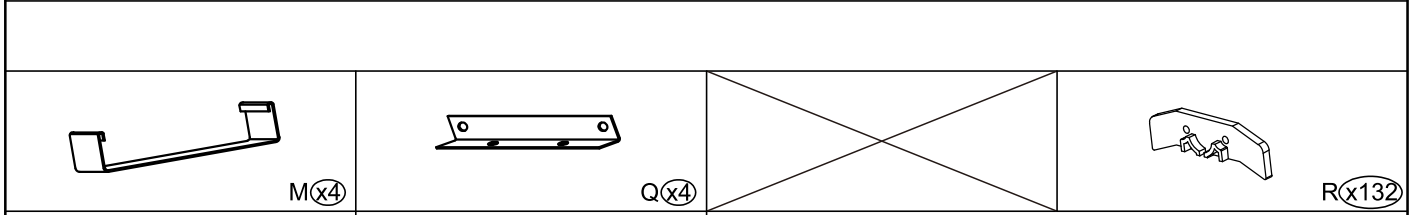



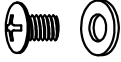

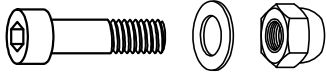
P(x65)

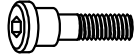

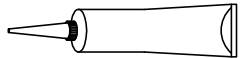
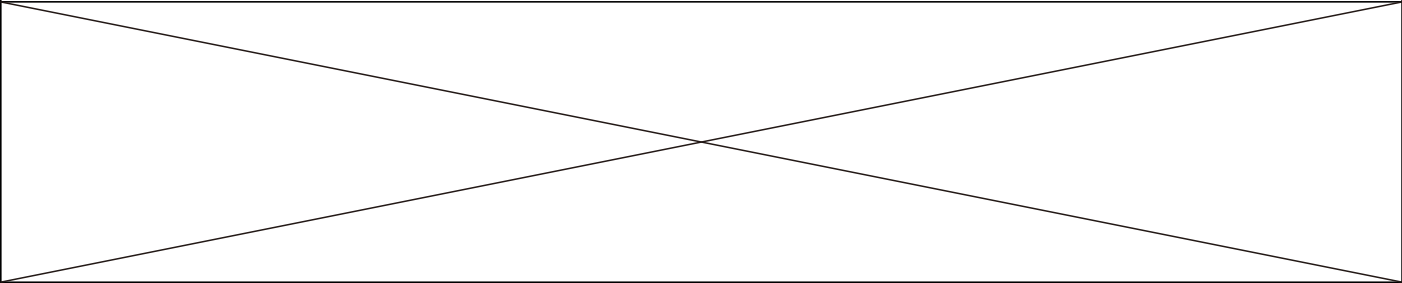
P1(x1)

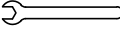
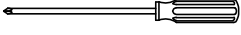

	M6x12	1# x260		
	M5x8	2# x99		
	M6x8	3# x6		
	ST4.2x16	4# x24		
	M8x32	5# x6		
	M6	6# x3		
	Plastic gaskets	7# x3		
		8# x3		
	4x6	9# x276		
	ST3.5x16	10# x264		
	Silicone sealant	11# x4		
				
 S6 x1	 S4 x1	 S10 x1	 S13 x1	 x1

# Assemble the base:

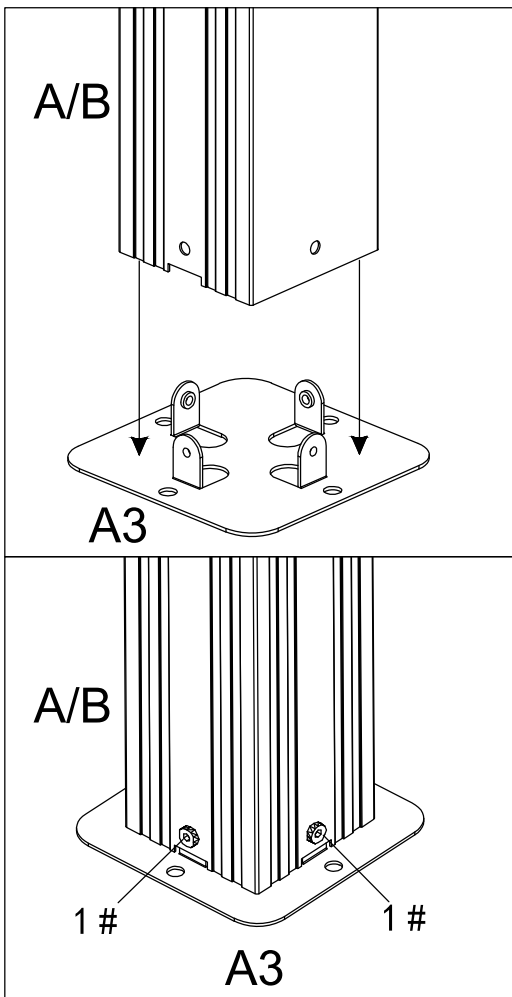
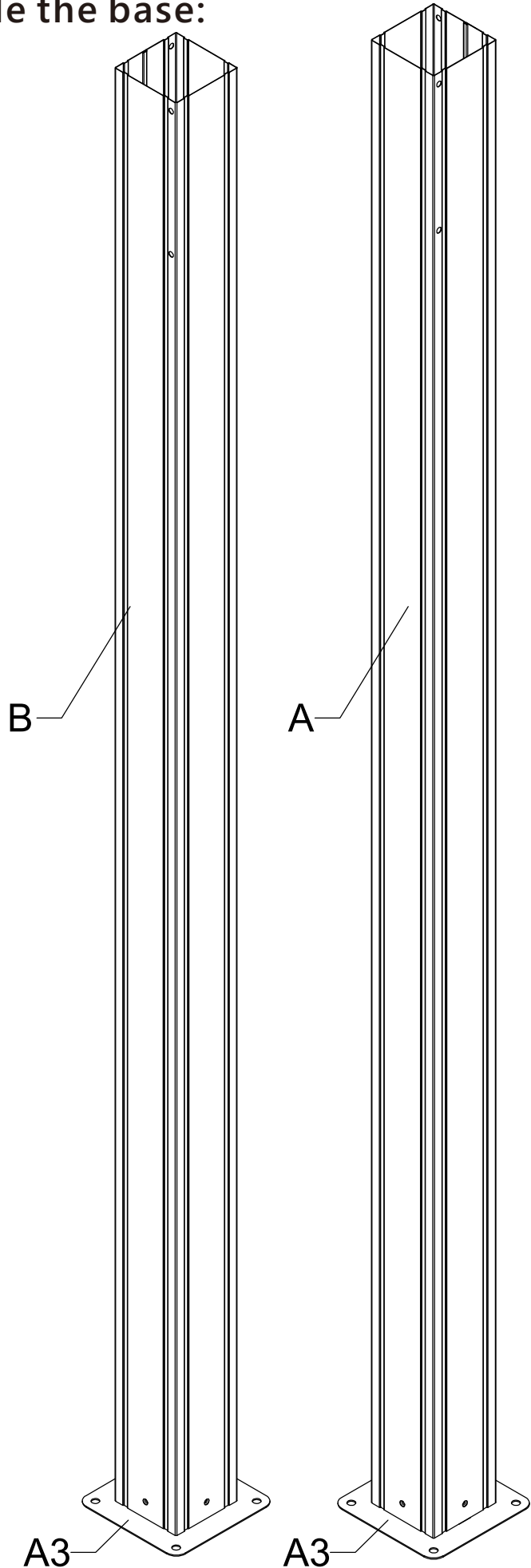
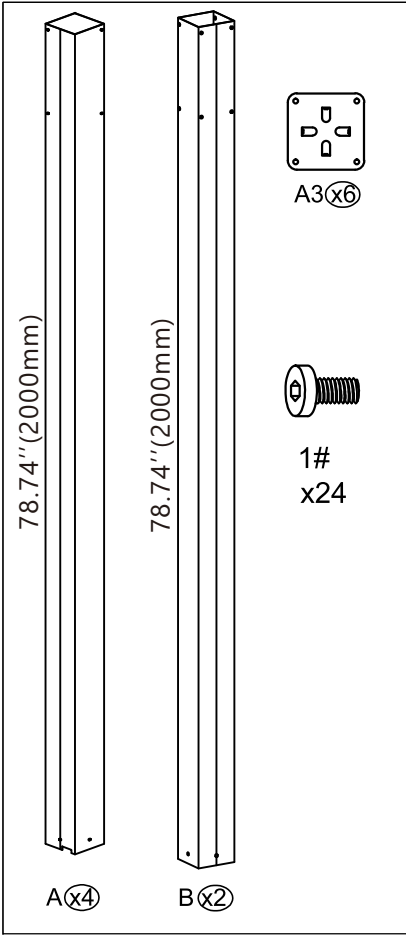

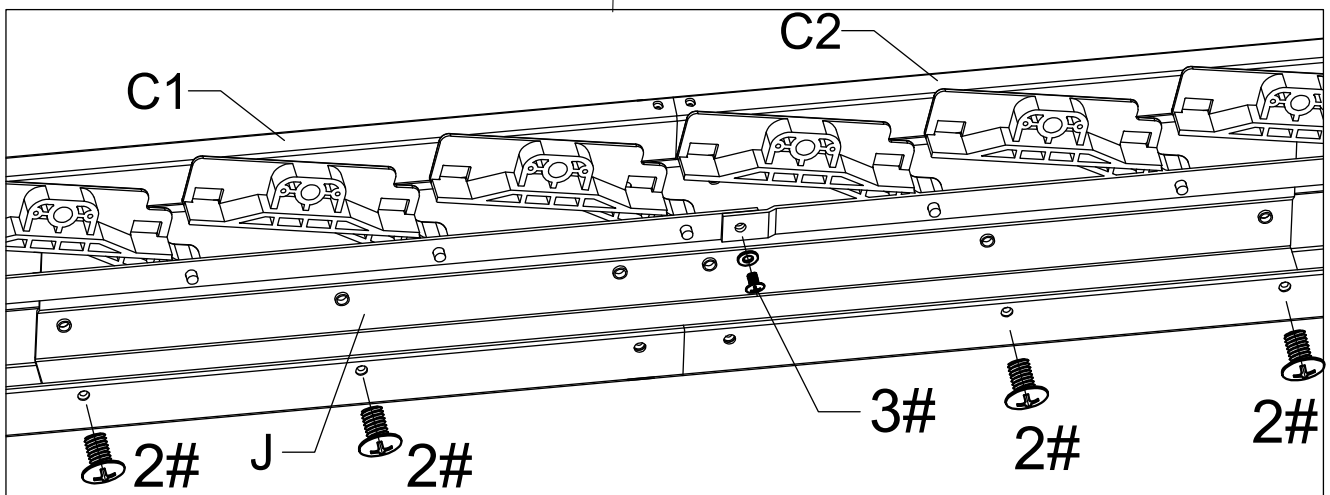
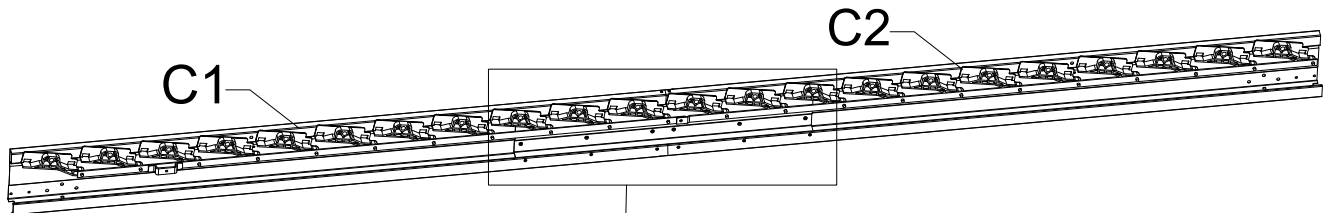
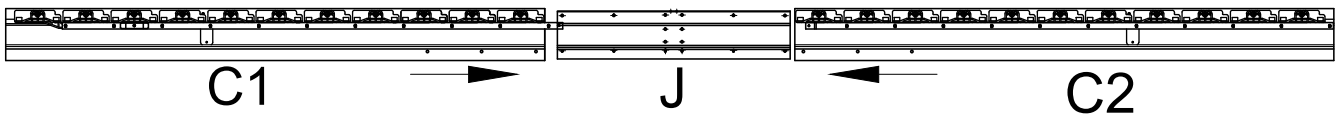

Insert Part #J into Part #C1 and Part #C2.  
 Align the holes, use 4 bolts #2 to secure Part #J with Part #C1 and Part #C2,  
 use bolts and washer #3 to secure the linkage rod.

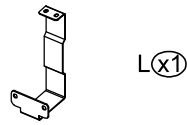

L(x1)



1#  
x18

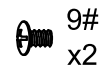

9#  
x2

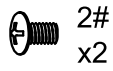

2#  
x2

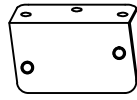

K1(x1)

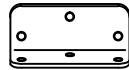

K(x1)

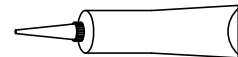

11#

Use 12 bolts #1 to secure Part #J with Part #C1 and Part #C2 (from outside).

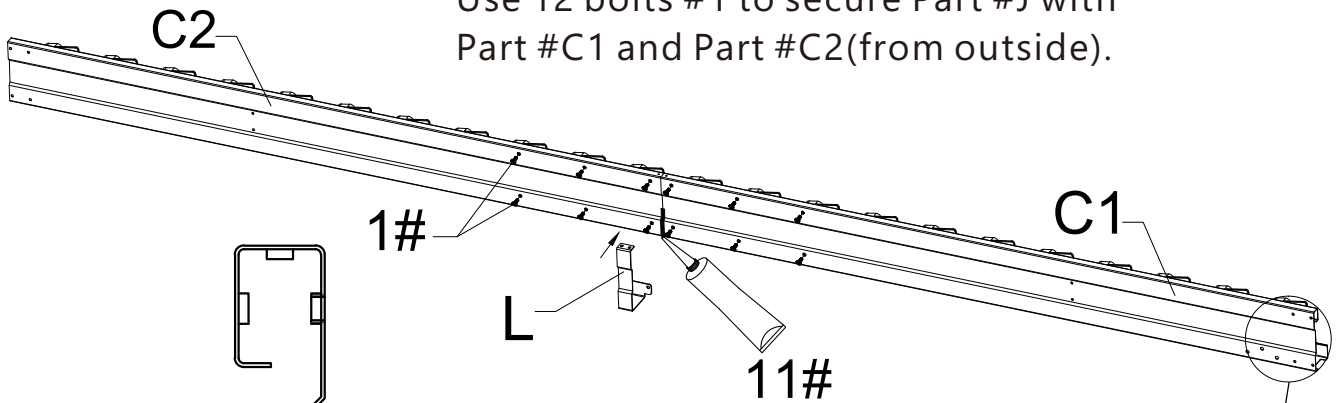

Use Silicone sealant to affix the gap between the two beams.

Cover the gap with Gap Cover #L, secure with 2 bolts #9 and 2 bolts #2 as shown.

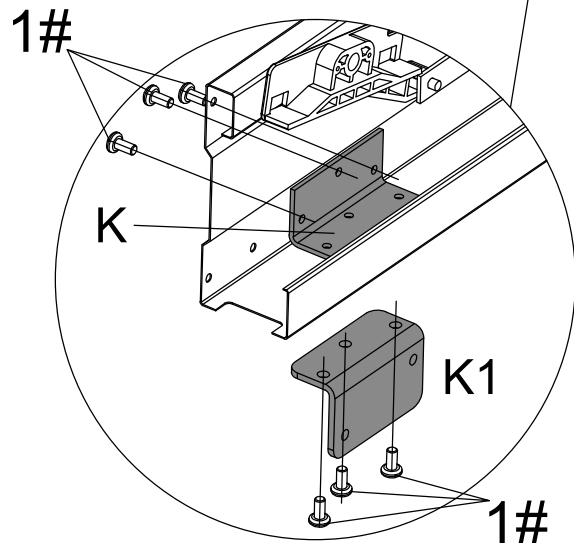
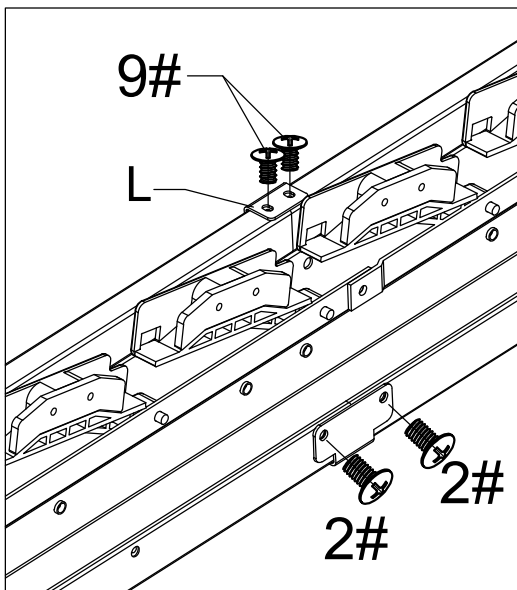

Use 3 bolts #1 to secure part #K, align the holes, use 3 bolts #1 to secure part #K1 to the beam with part #K.

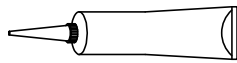

11#

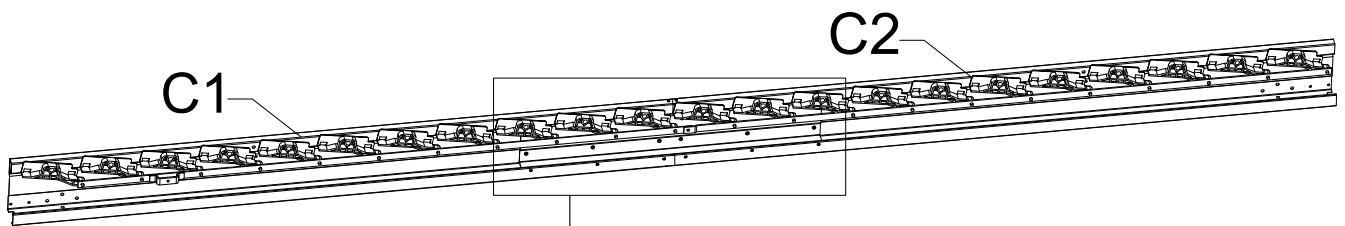

Inside View

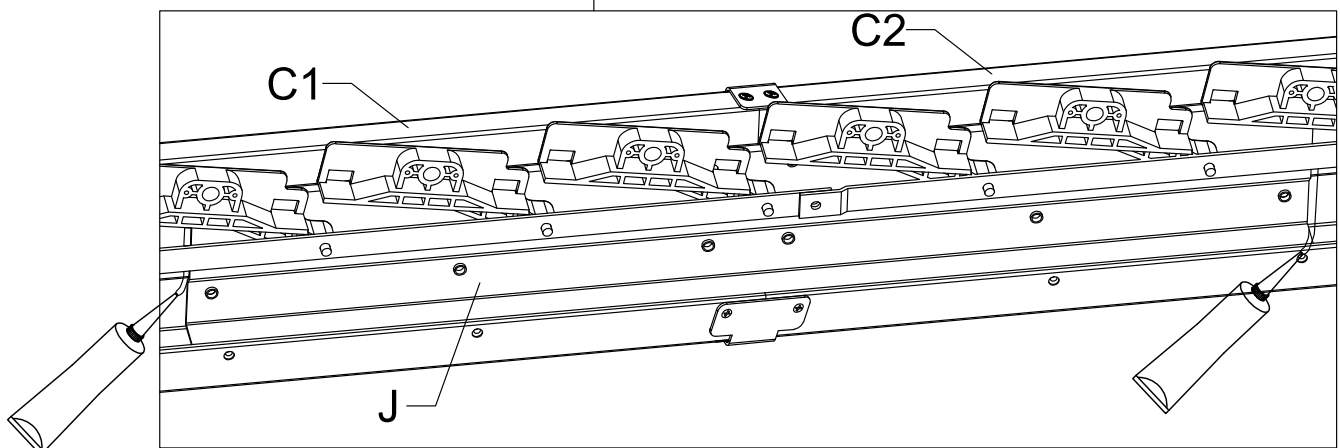

Seal both ends of the beam connector #J with sealant.

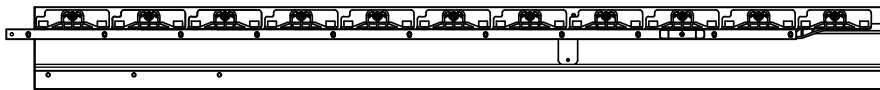

D1(x1)

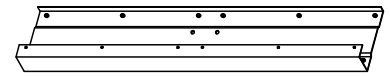

J(x1)

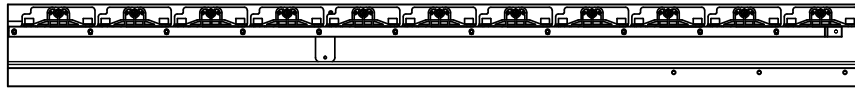

D2(x1)

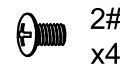

2#  
x4



3#  
x1

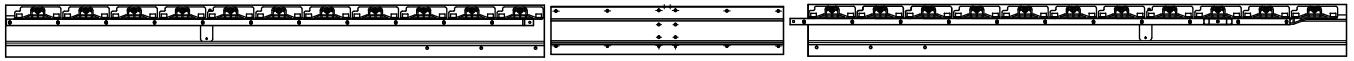

D2

J

D1

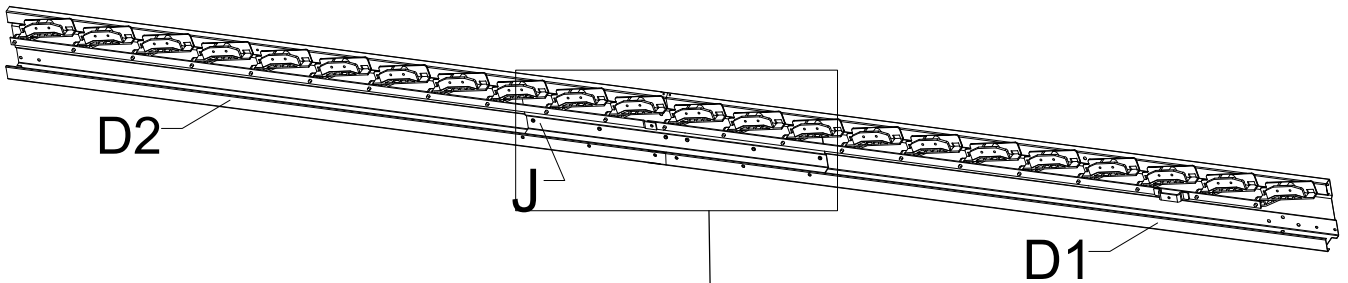

D2

J

D1

D2

D1

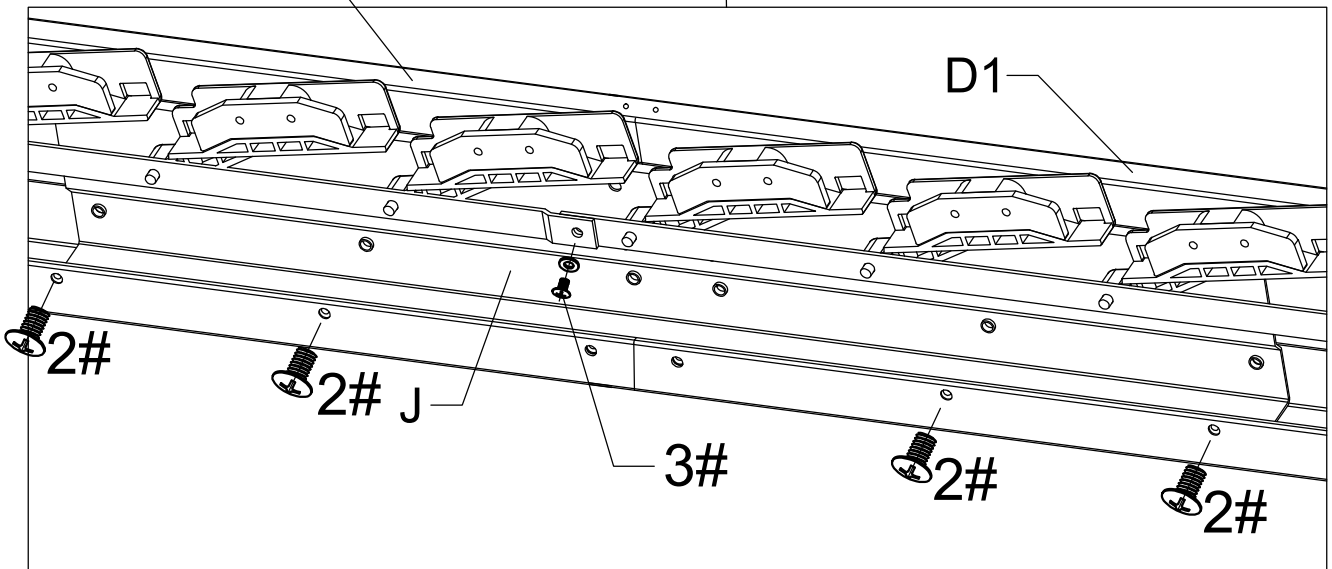

2#

2# J

3#

2#

2#

Insert Part #J into Part #D1 and Part #D2.

Align the holes, use 4 bolts #2 to secure Part #J with Part #D1 and Part #D2, use bolts and washer #3 to secure the linkage rod.

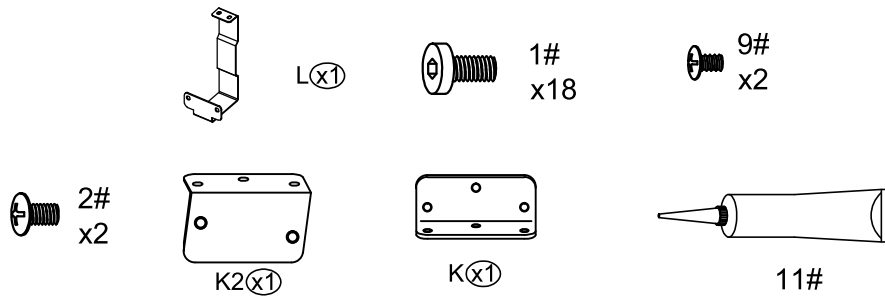

Use 12 bolts #1 to secure Part #J with Part #D1 and Part #D2 (from outside).

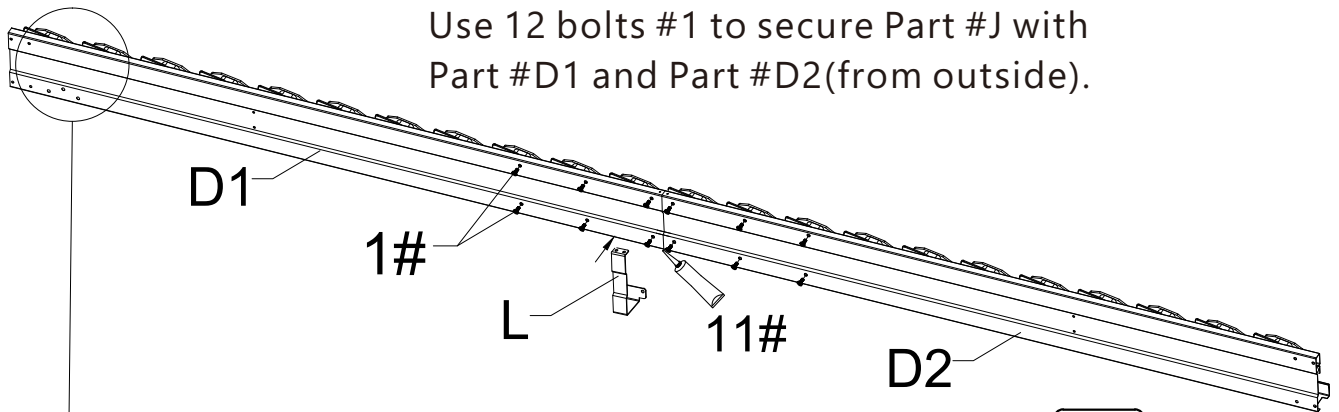

Use Silicone sealant to affix the gap between the two beams.

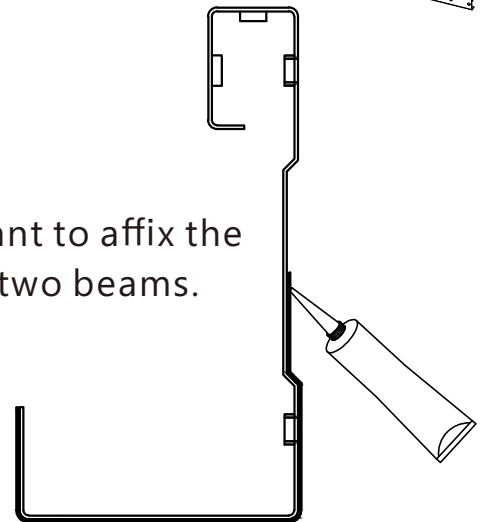

Cover the gap with Gap Cover #L, secure with 2 bolts #9 and 2 bolts #2 as shown.

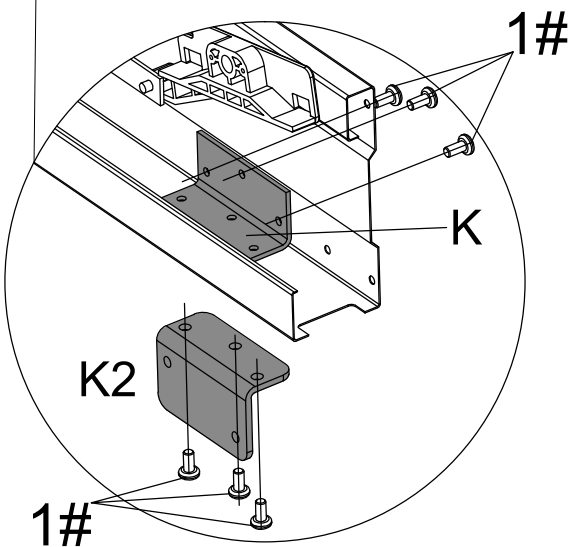

Use 3 bolts #1 to secure part #K, align the holes, use 3 bolts #1 to secure part #K2 to the beam with part #K.

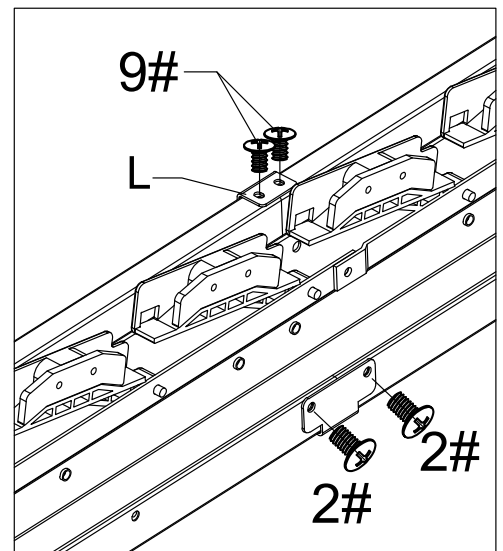

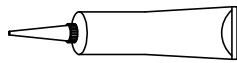

11#

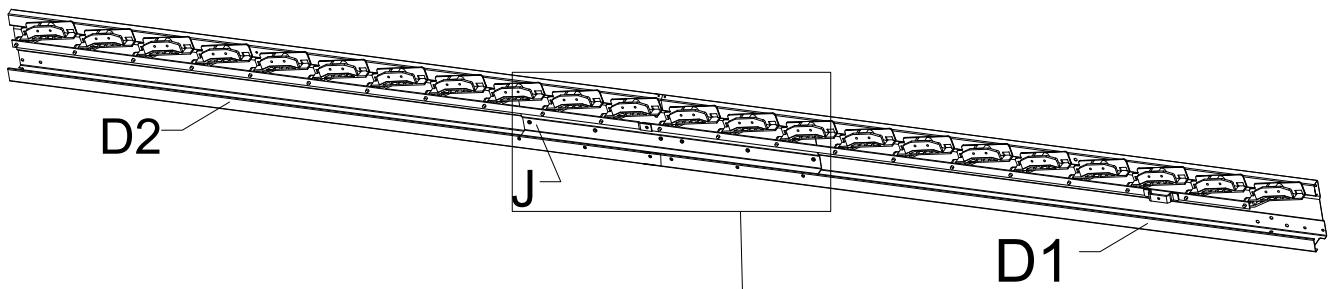

D2

J

D1

D2 Inside View

D1

11#

J

11#

Seal both ends of the beam connector #J with sealant.

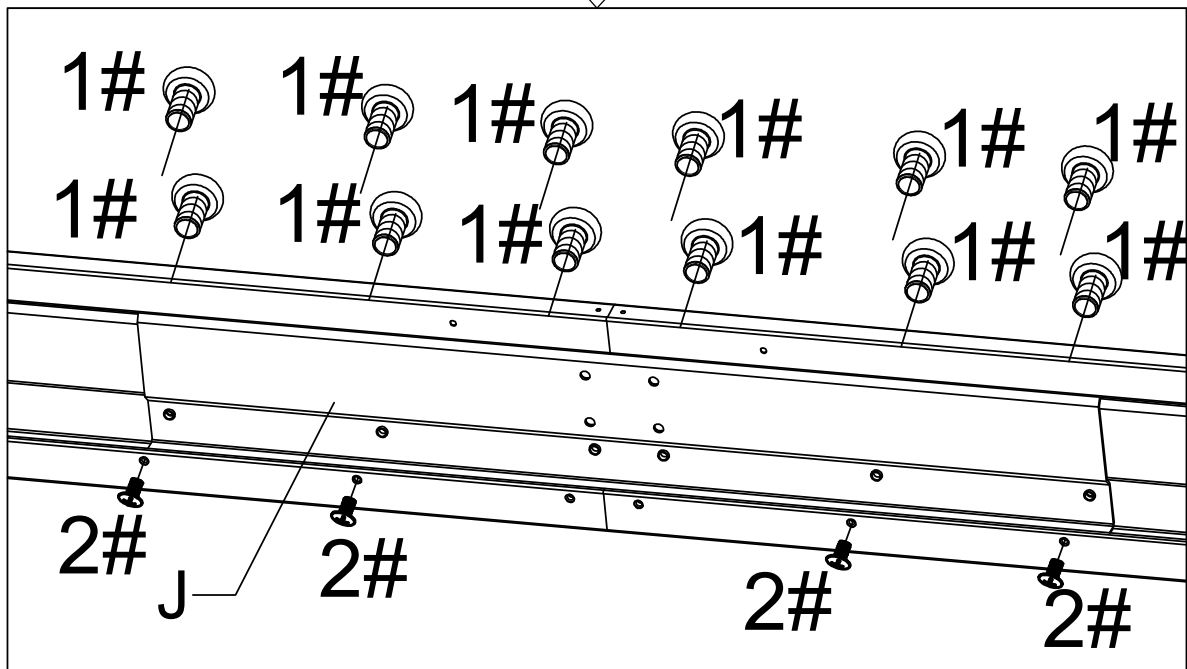
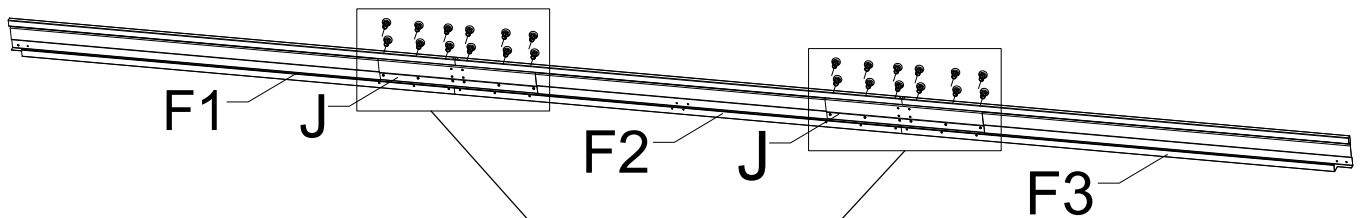
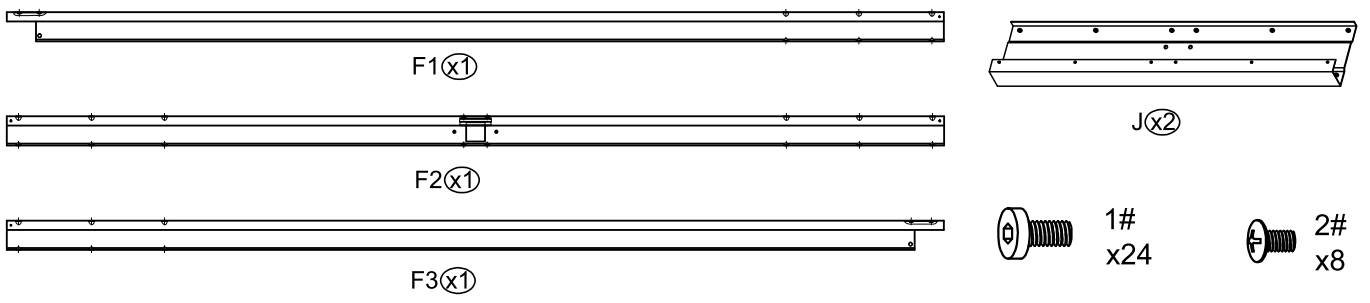

Insert Part #J into Part #F1 and #F2.  
 Align the holes, use 4 bolts #2 to secure Part #J with Part #F1 and Part #F2 (from inside).  
 Use 12 bolts #1 to secure Part #J with Part #F1 and Part #F2(from outside).  
 Repeat above procedures to assemble Part #J with Part #F2 and #F3.

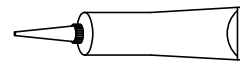
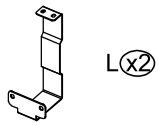

11#

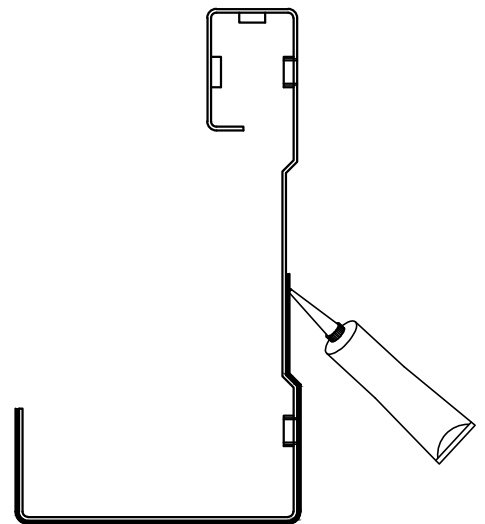
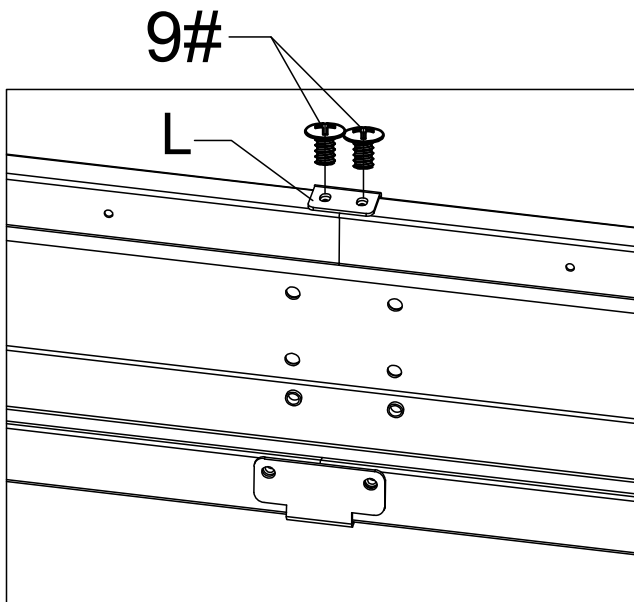
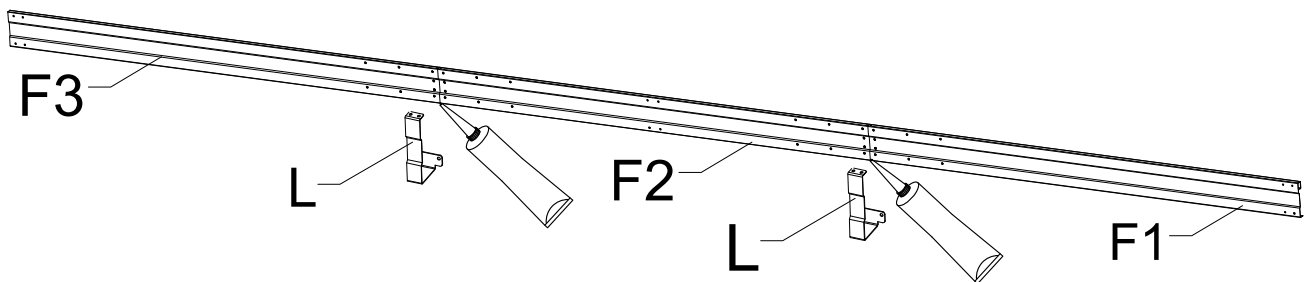

Use Silicone sealant to affix the gap between the beams.  
Cover the gap with Gap Cover #L, secure with bolts #9.

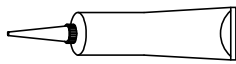

11#

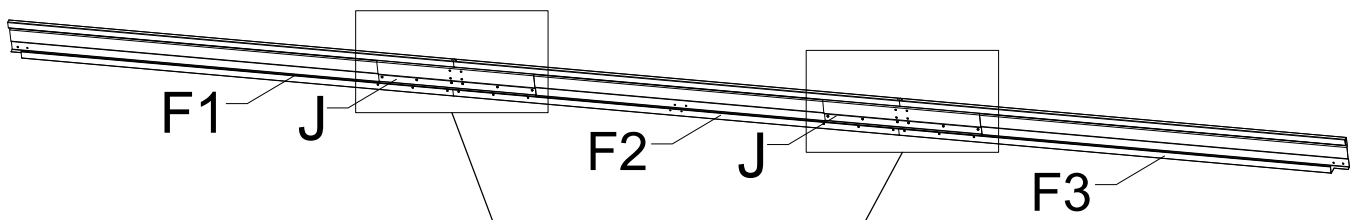

Inside View

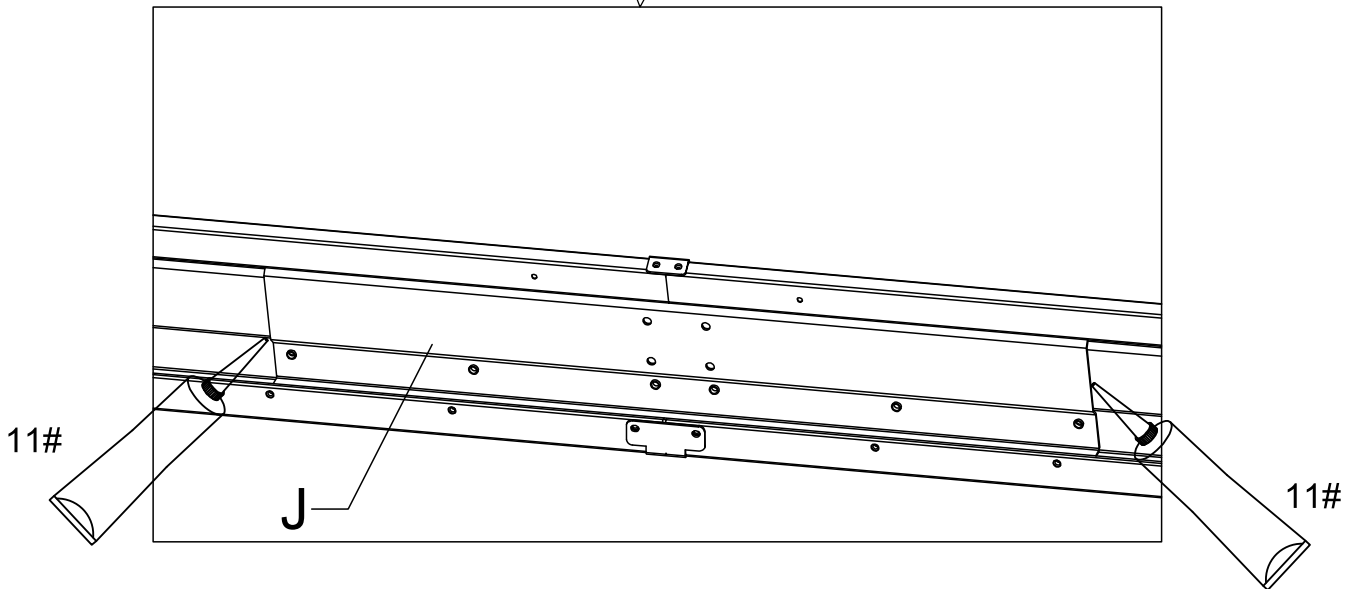

Seal both ends of the beam connector #J with sealant.

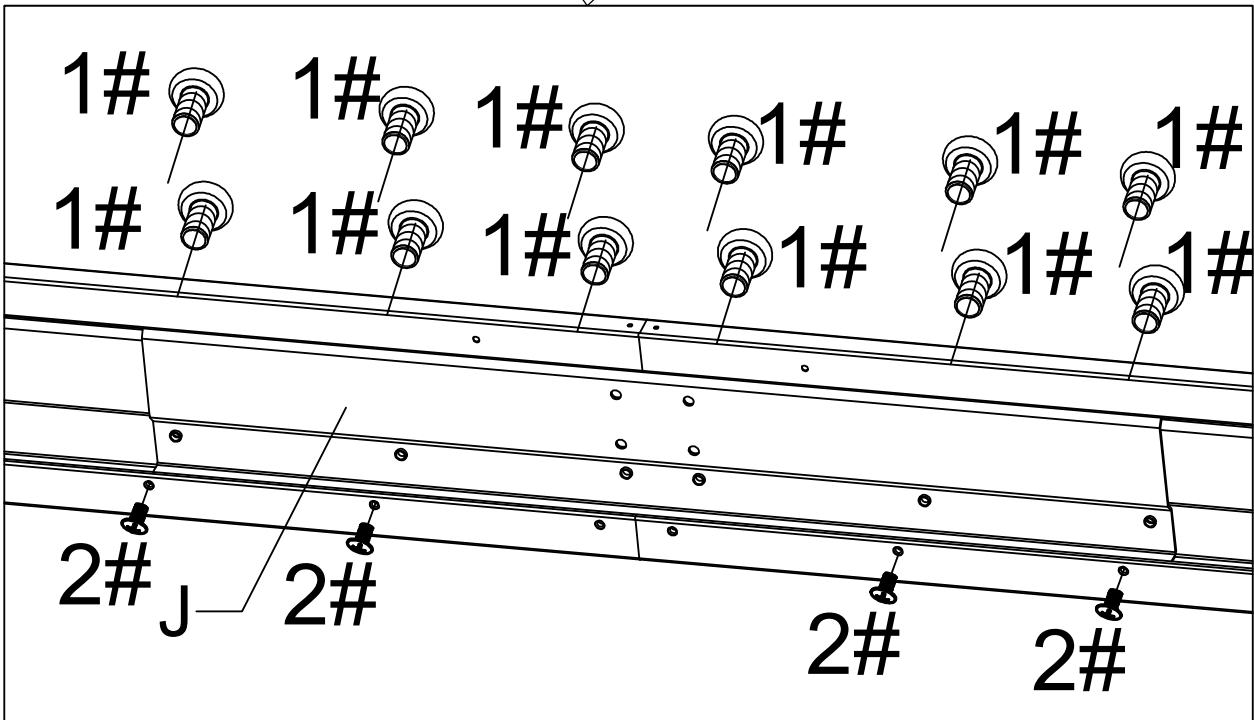
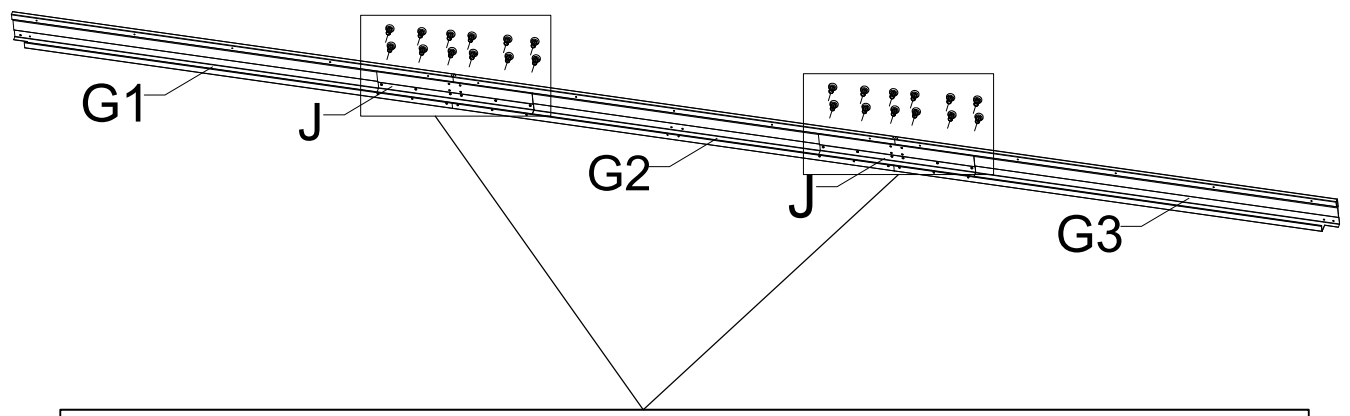
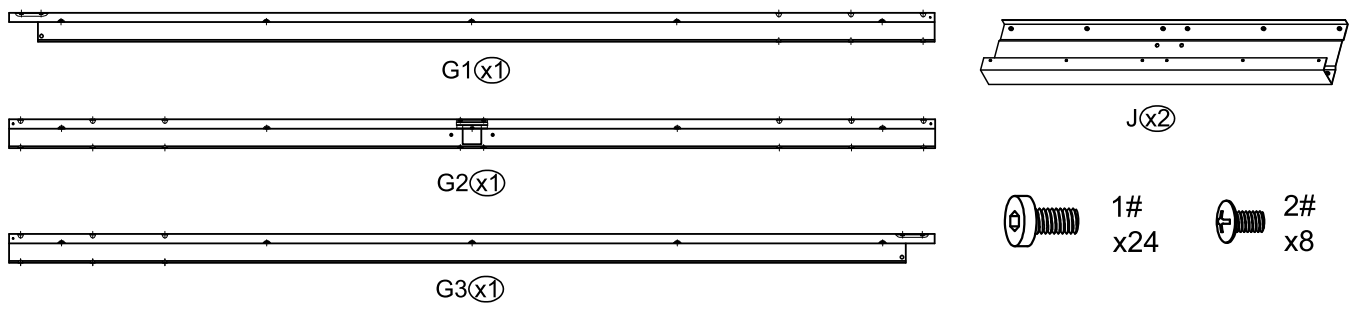

Insert Part #J into Part #G1 and #G2.  
 Align the holes, use 4 bolts #2 to secure Part #J with Part #G1 and Part #G2 (from inside).  
 Use 12 bolts #1 to secure Part #J with Part #G1 and Part #G2 (from outside).  
 Repeat above procedures to assemble Part #J with Part #G2 and #G3.

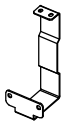

L x2



9#  
x4

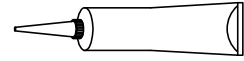

11#

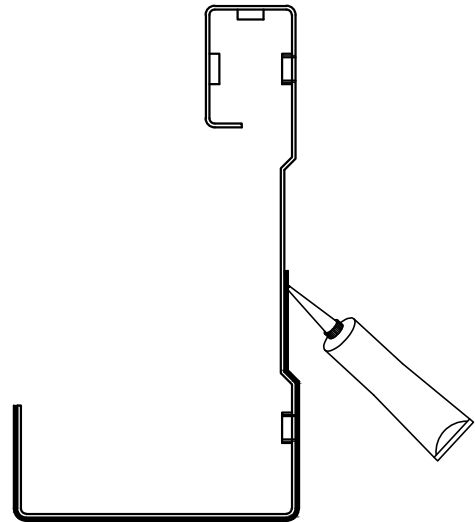
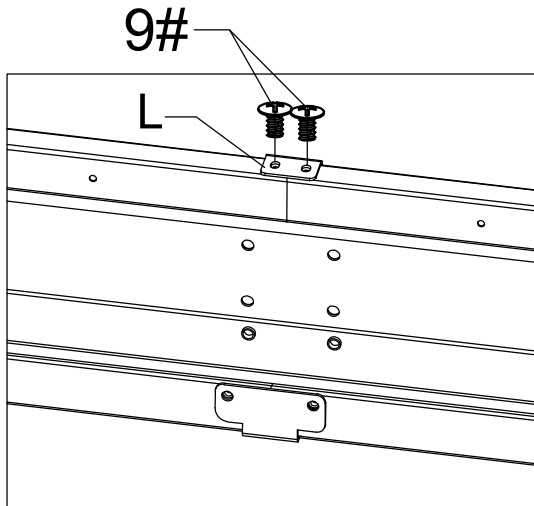
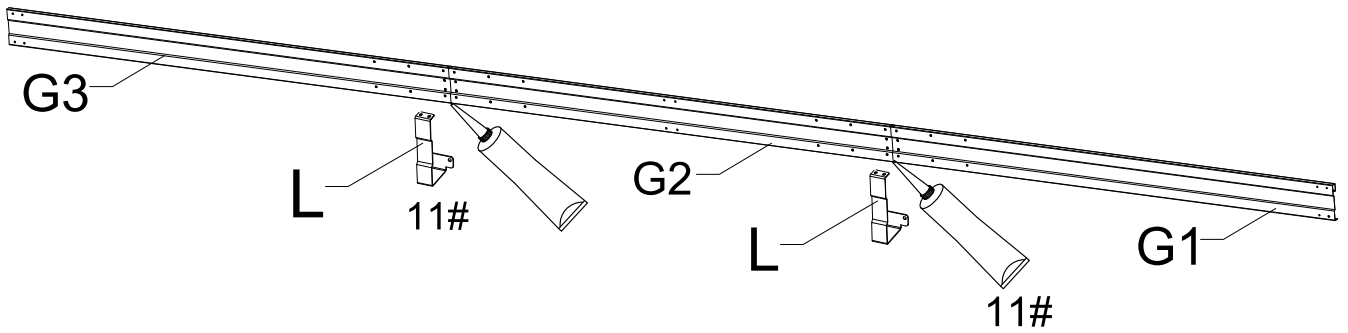

Use Silicone sealant to affix the gap between the beams.  
Cover the gap with Gap Cover #L, secure with bolts #9.

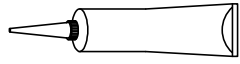

11#

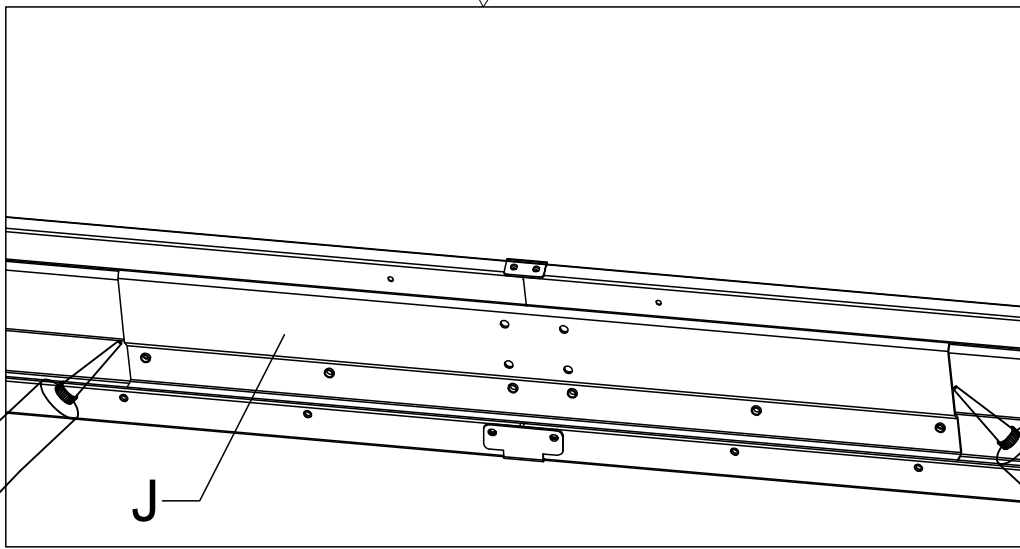
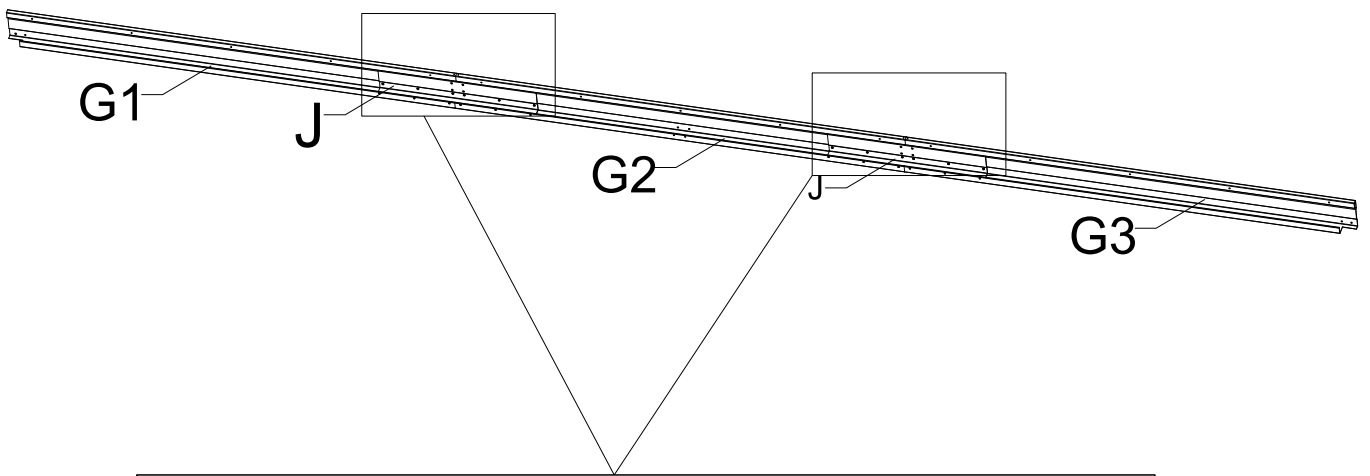

11#

Seal both ends of the beam connector #J with sealant.

11#

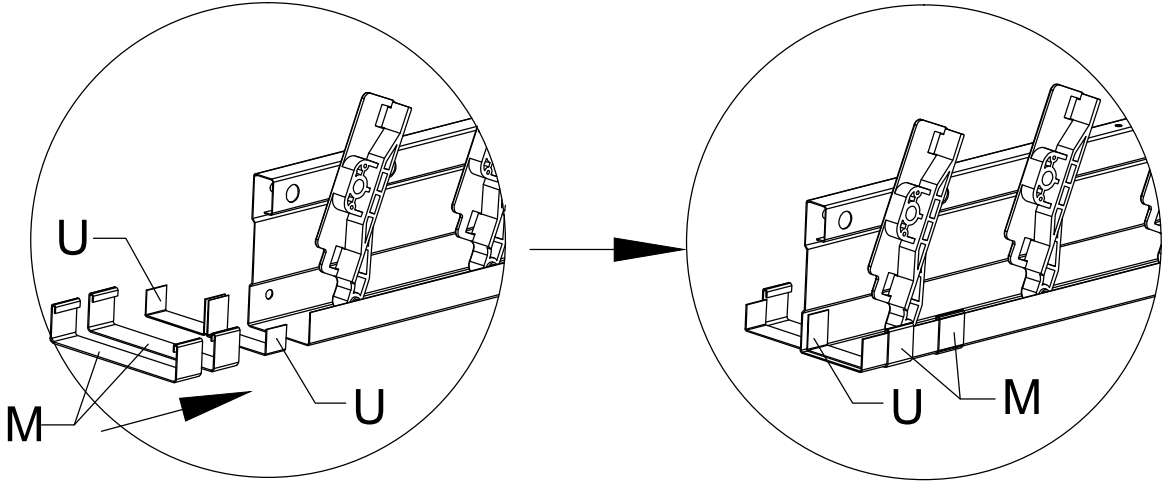
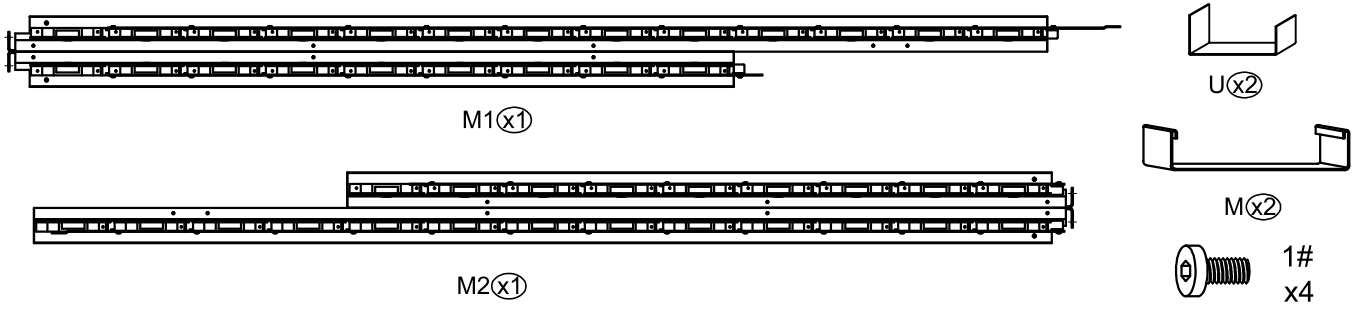

Place the U-shaped joint cover #U in each groove, snap on the U-shaped joint cover #M from the bottom, then connect the two beams.

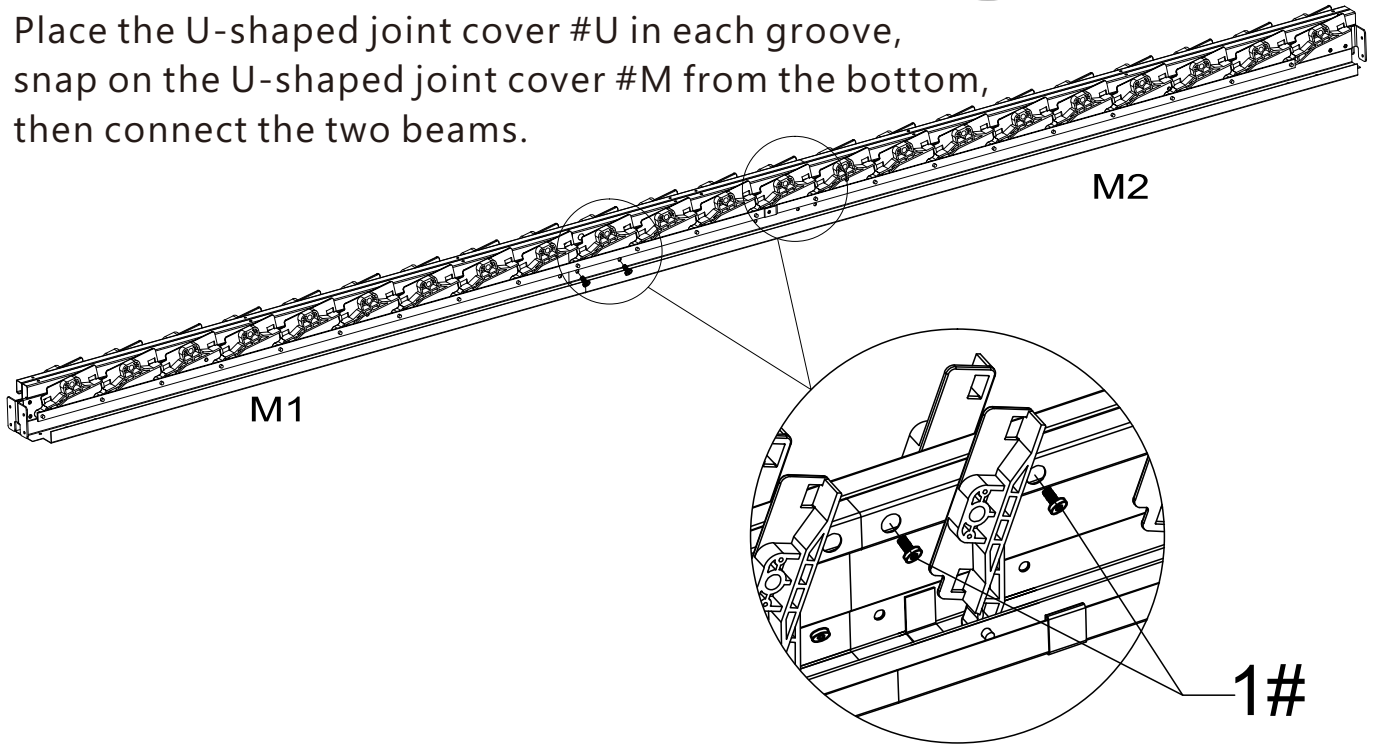

Use 4 bolts #1 to secure the 2 beams(the upper).

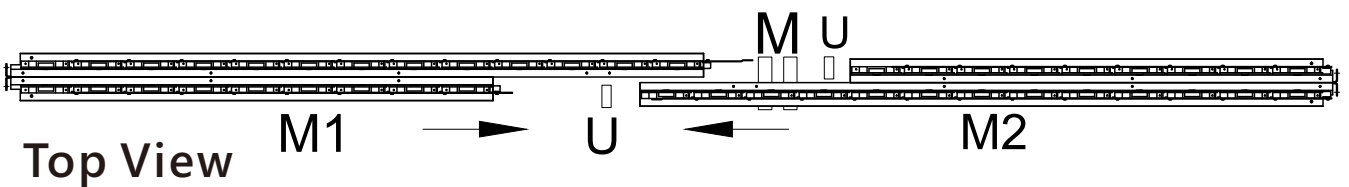

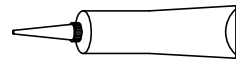

11#

Apply waterproof sealant to fill the inner side of the gap, then push part #U onto the joint to seal it.

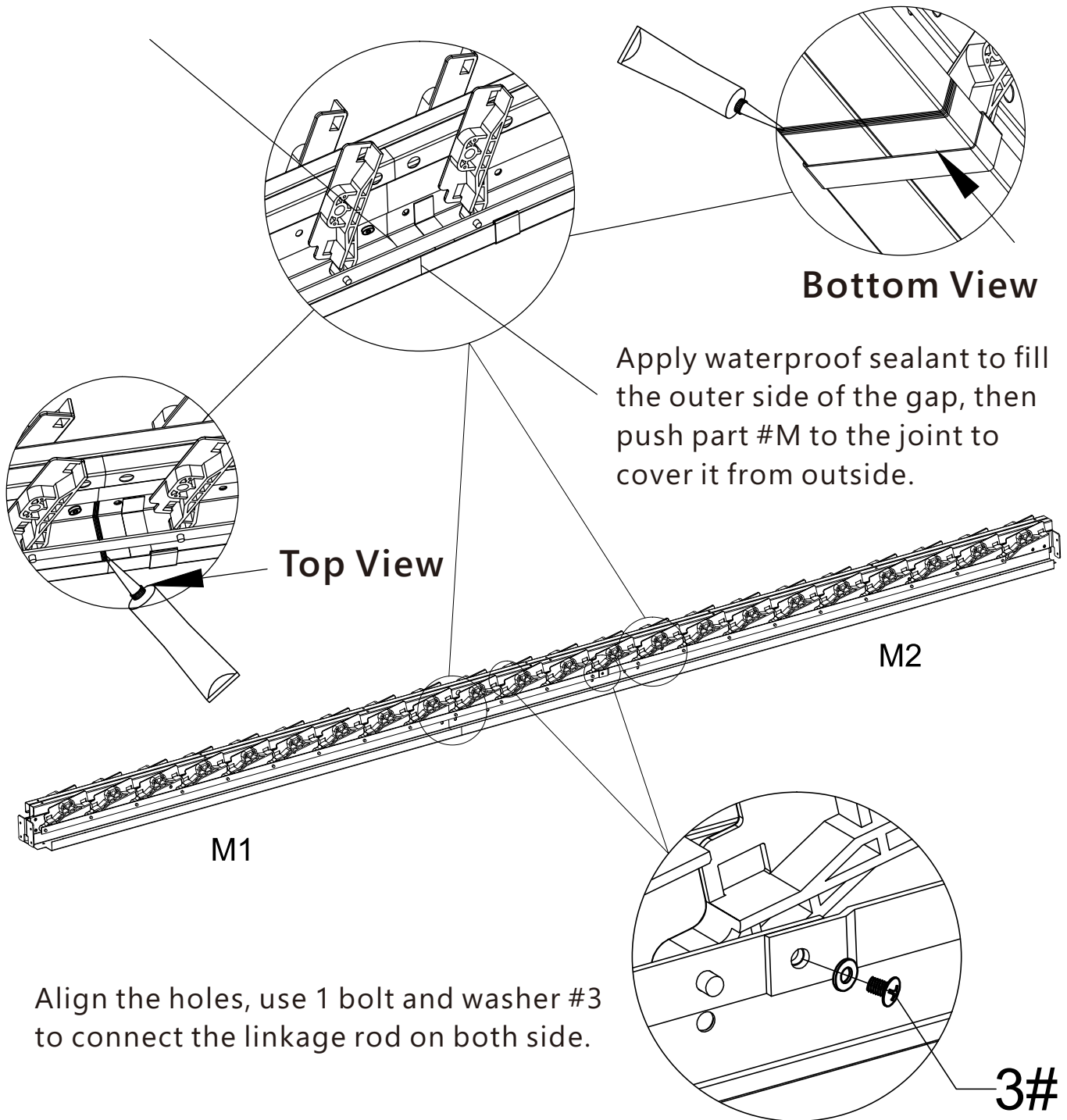

Align the holes, use 1 bolt and washer #3 to connect the linkage rod on both side.

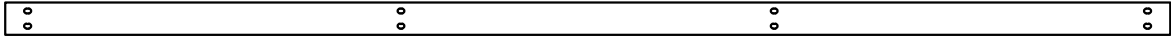

N(x2)



1#  
x4



2#  
x16

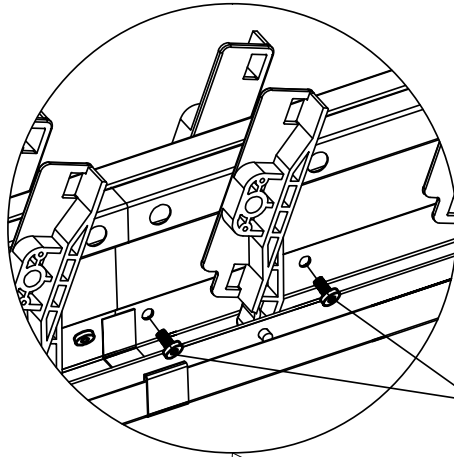

1#

Use 4 bolts #1 to secure the 2 beams (the under).

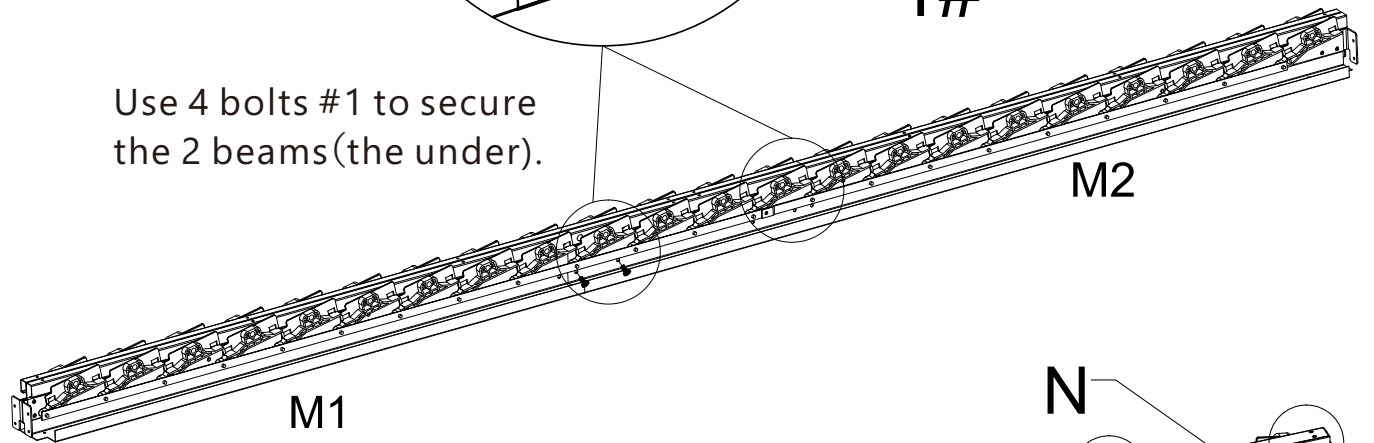

M1

M2

N

N

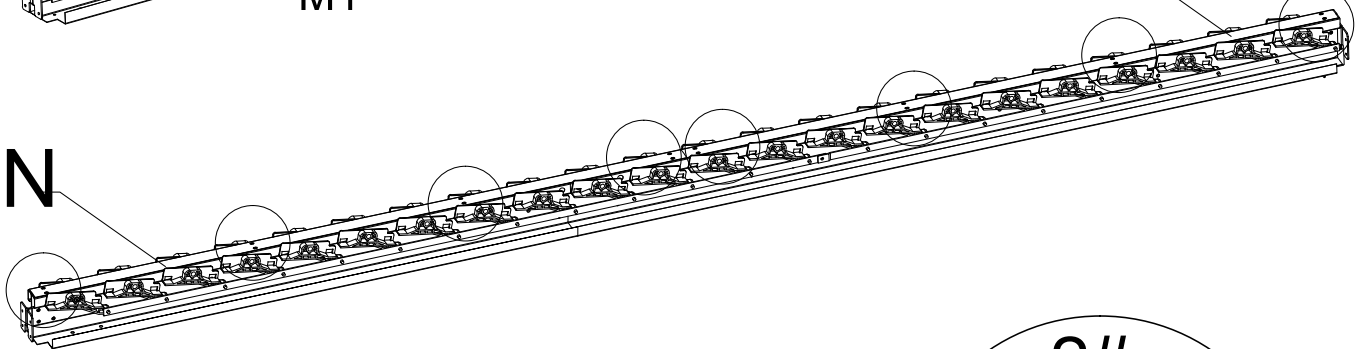

N

2#

2#

Place Gap Cover #N on the beam , align the holes and fix with 16 bolts #2.

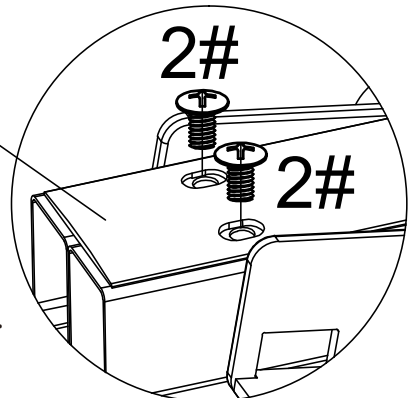

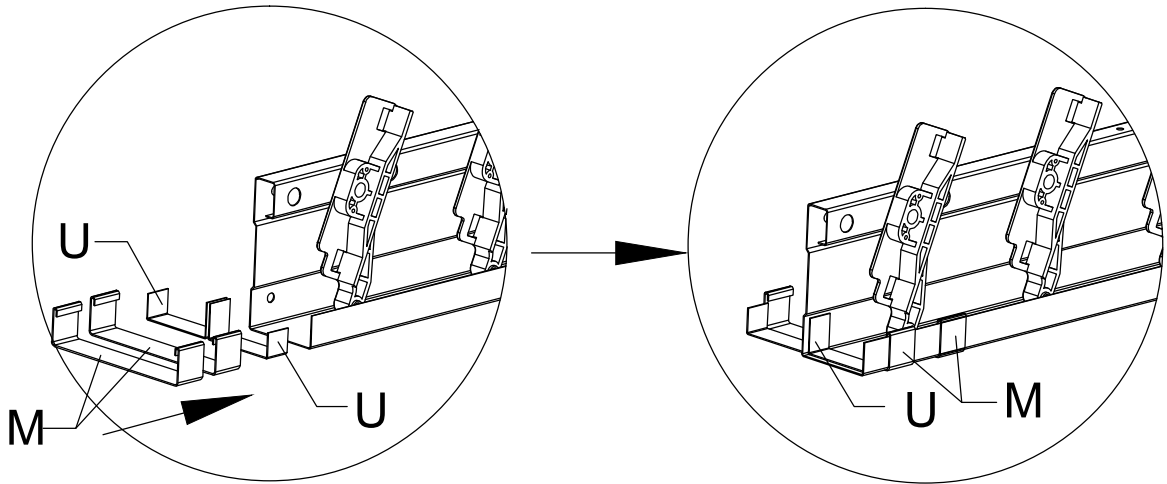
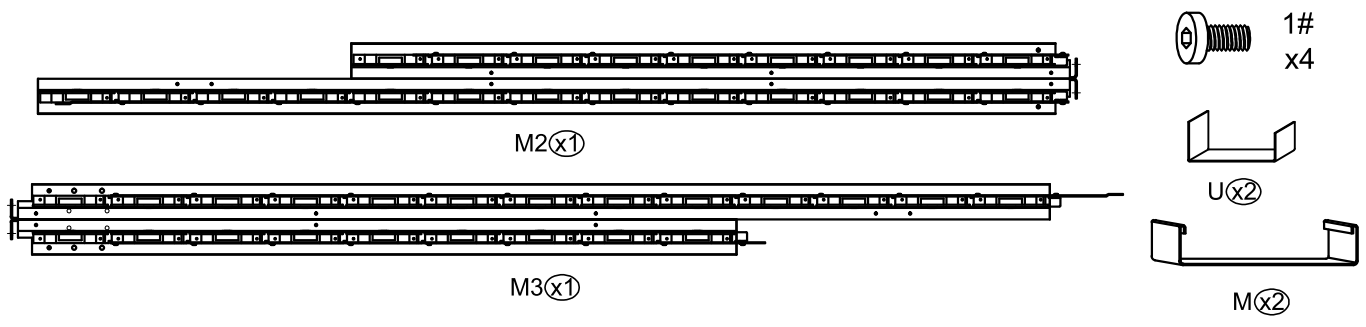

Place the U-shaped plastic joint cover #U in each groove, snap on the U-shaped joint cover #M from the bottom, then connect the two beams.

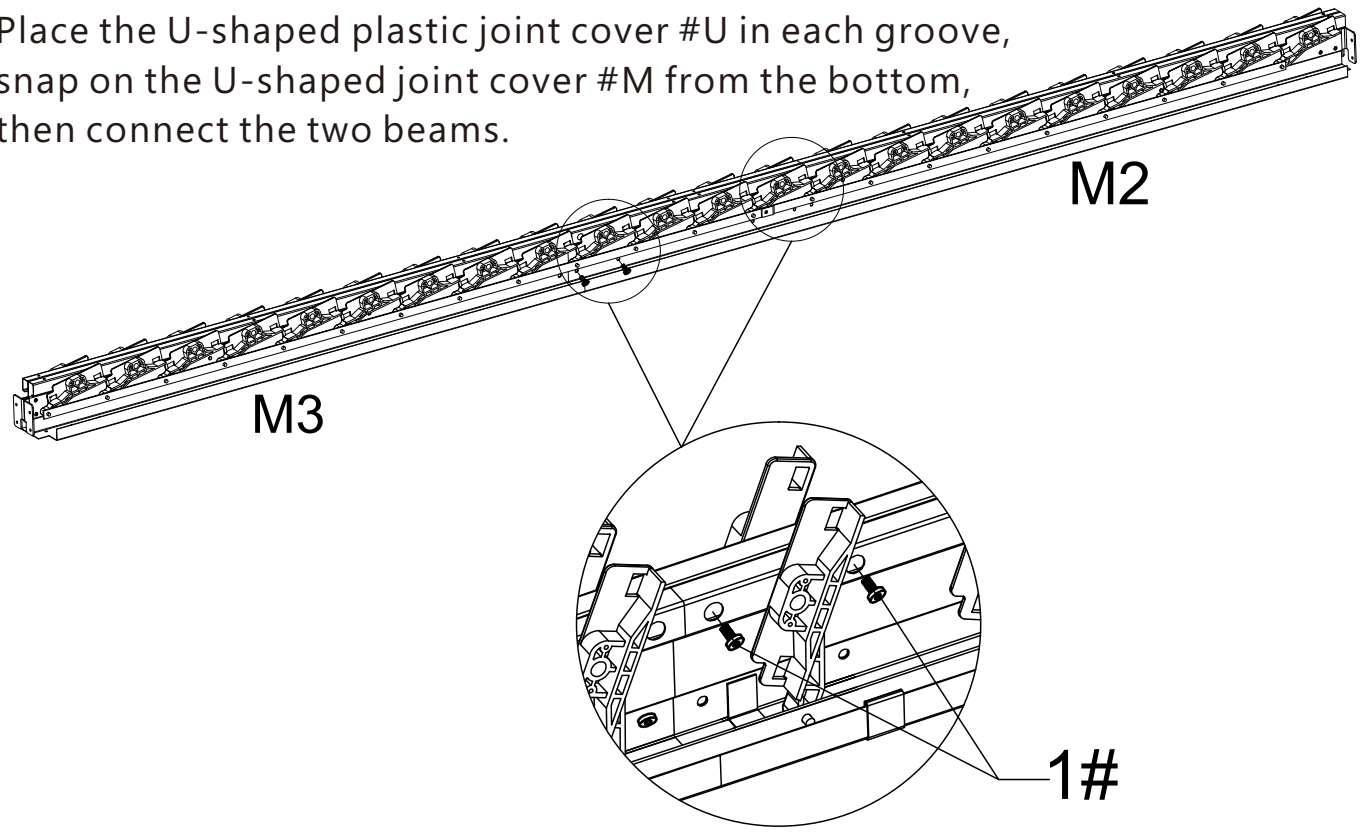

Use 4 bolts #1 to secure the 2 beams (the upper).

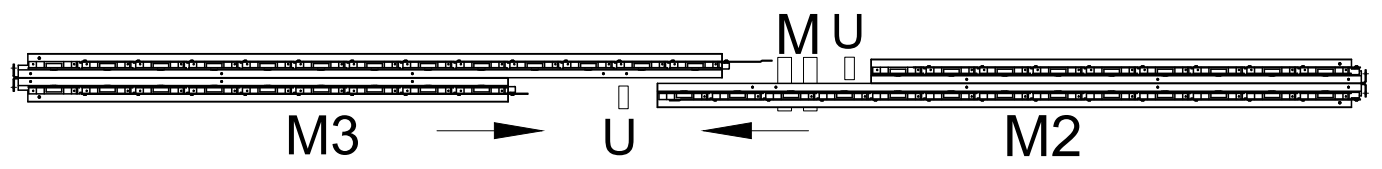

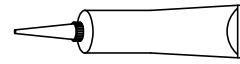
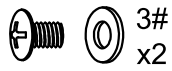

11#

Apply waterproof sealant to fill the inner side of the gap, then push part #U onto the joint to seal it.

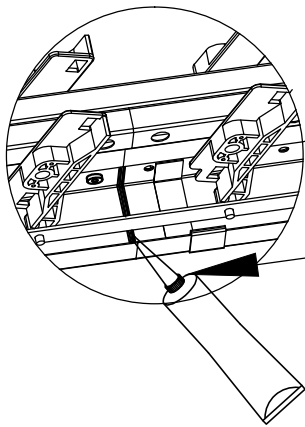

Top View

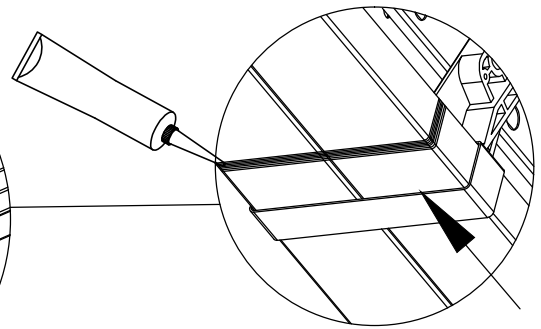
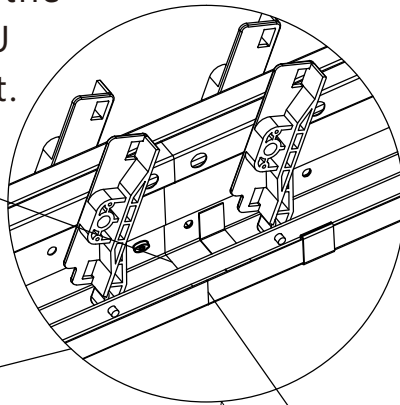

Bottom View

Apply waterproof sealant to fill the outer side of the gap, then push part #M to the joint to cover it from outside.

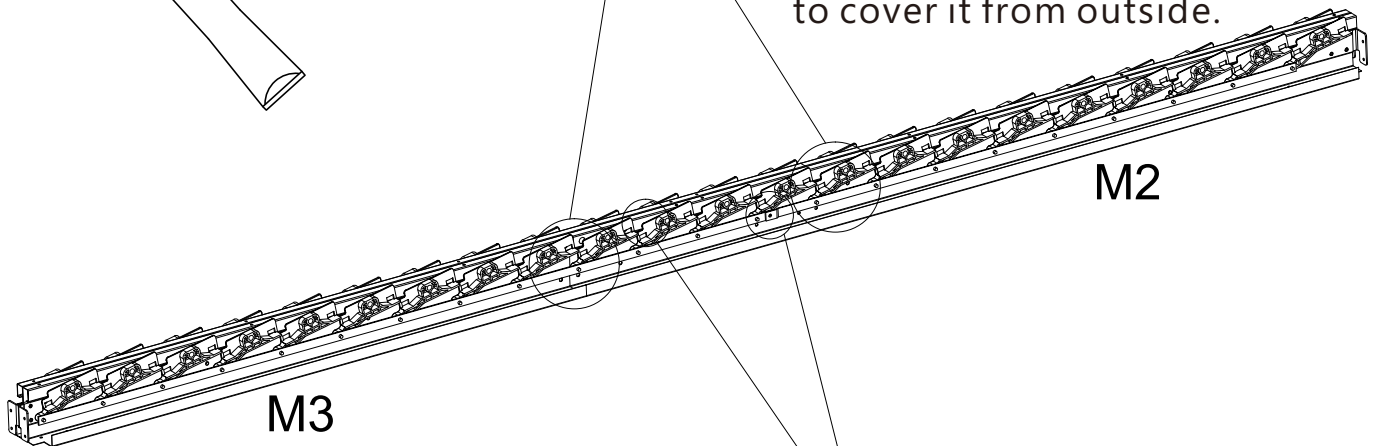

Align the holes, use 1 bolt and washer #3 to connect the linkage rod on both side.

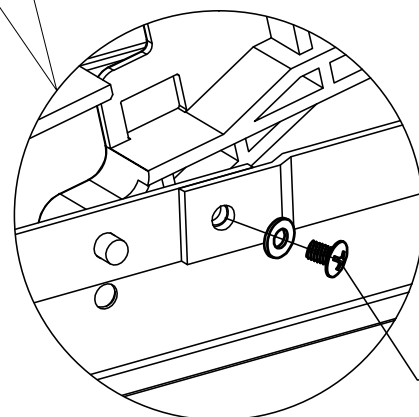

3#

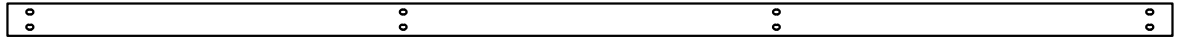

N(x2)

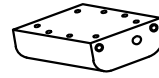
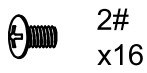
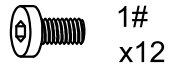

E(x1)

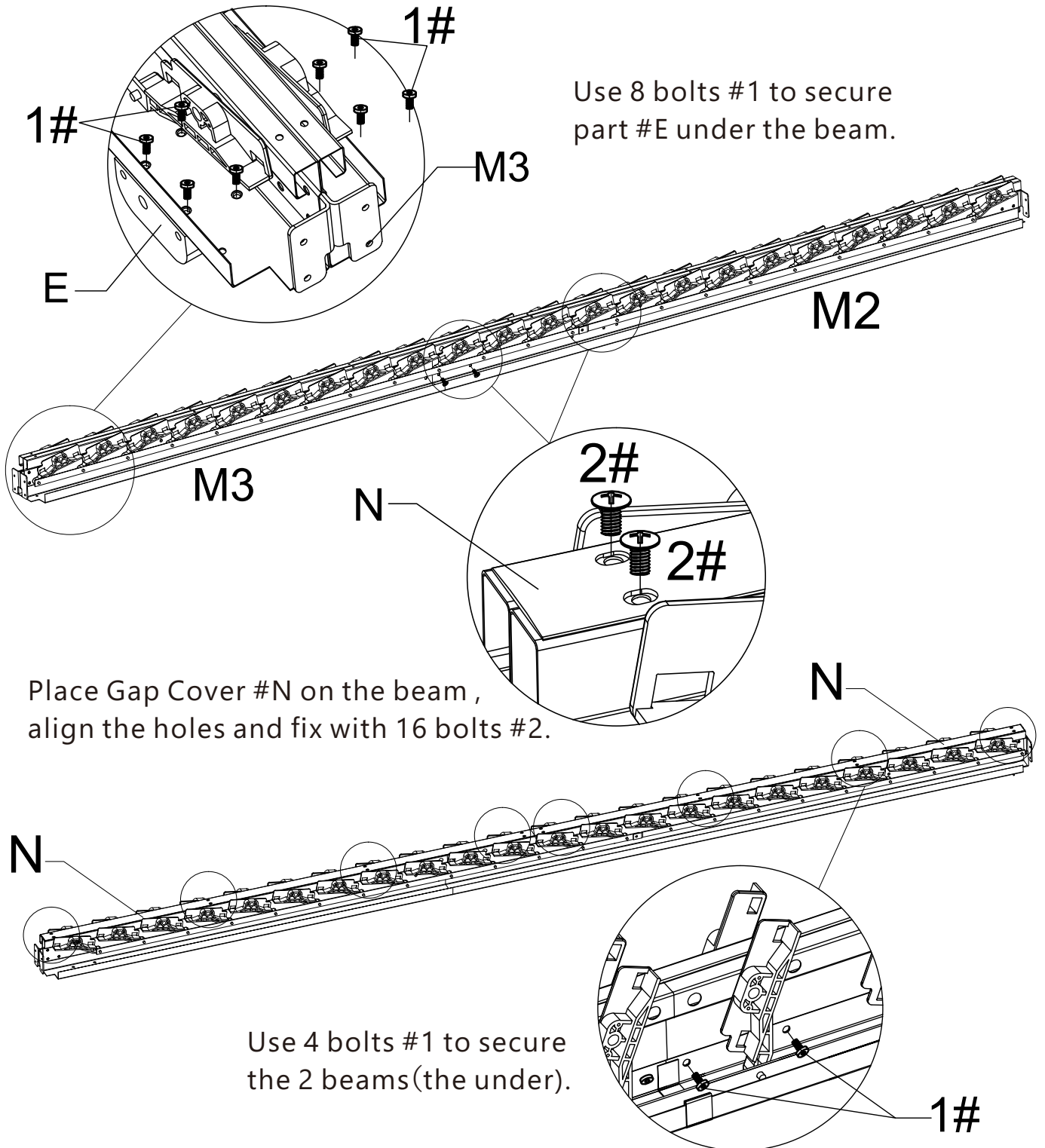

Use 8 bolts #1 to secure part #E under the beam.

Place Gap Cover #N on the beam, align the holes and fix with 16 bolts #2.

Use 4 bolts #1 to secure the 2 beams (the under).

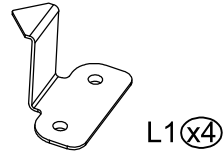
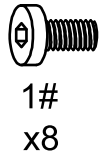

Attention: Before assembling the beams, ensure that all the Linkage Rods are facing down and the plastic pieces are facing up.

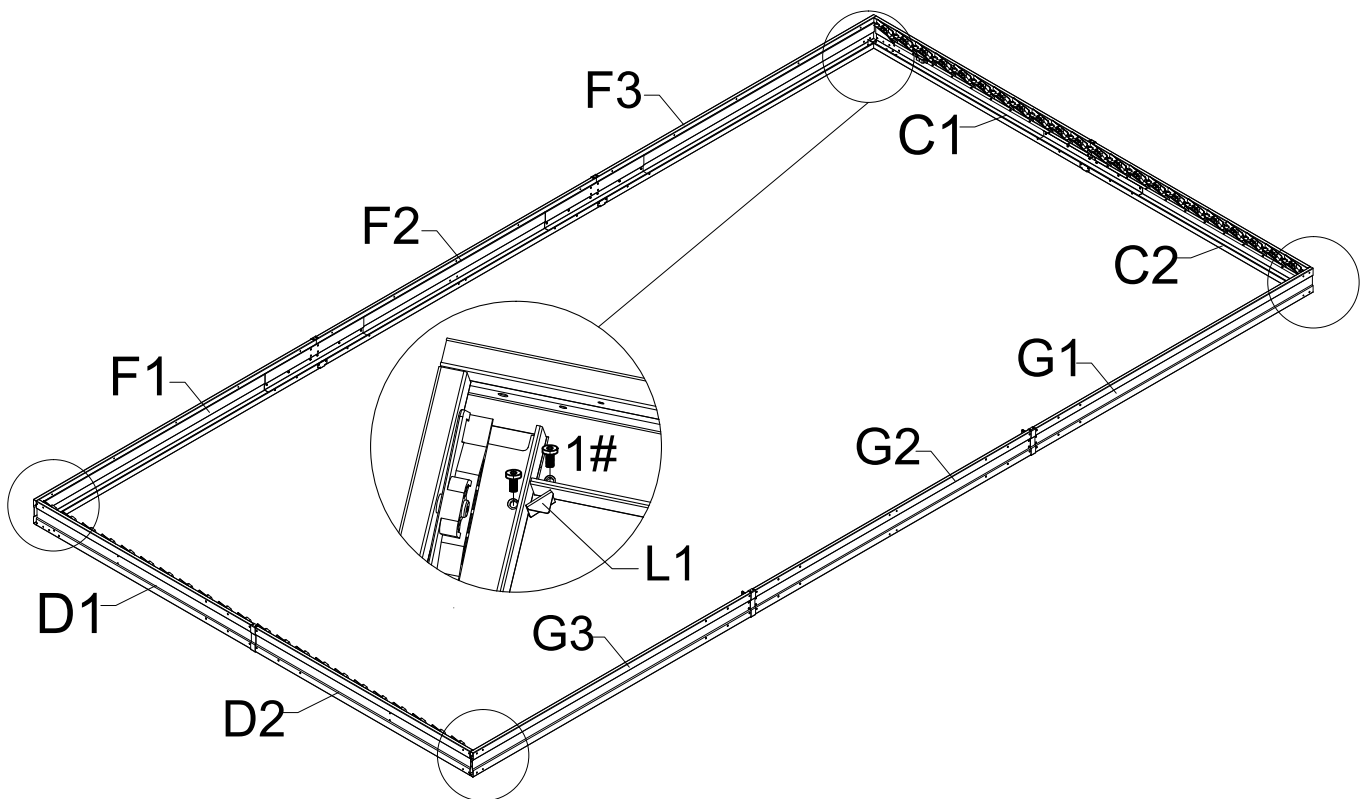

Connect the beams as shown, align the holes and use bolts #8 and brackets #L1 to secure each corner.

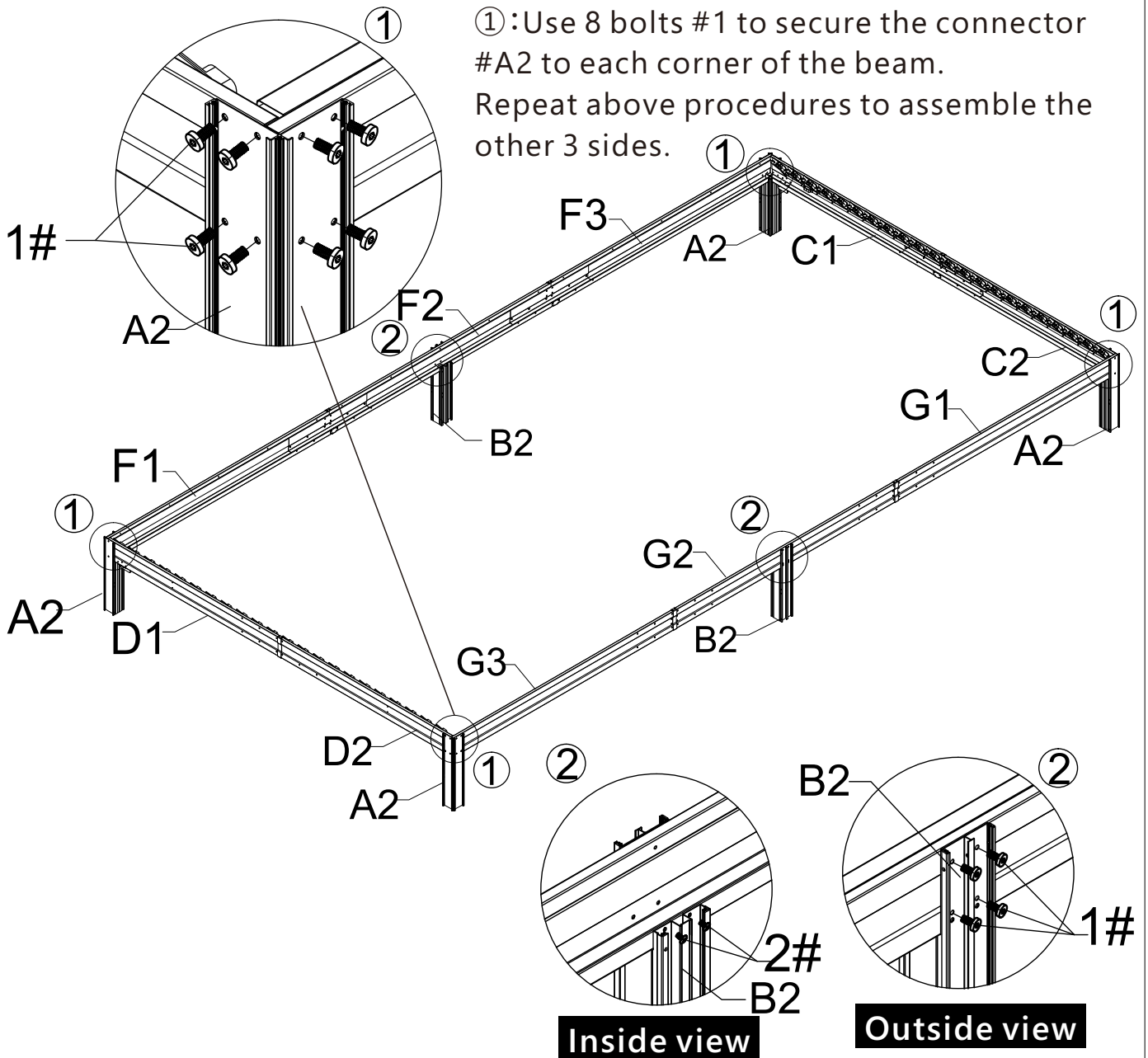
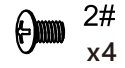
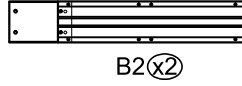

①: Use 8 bolts #1 to secure the connector #A2 to each corner of the beam. Repeat above procedures to assemble the other 3 sides.

②: Use 4 bolts #1 to secure the connector #B2 to the centre of the beam as shown (from outside). Use 2 bolts #2 to secure the connector #B2 to the centre of the beam as shown (from inside). Repeat above procedures to assemble the opposite side.



1#  
x16

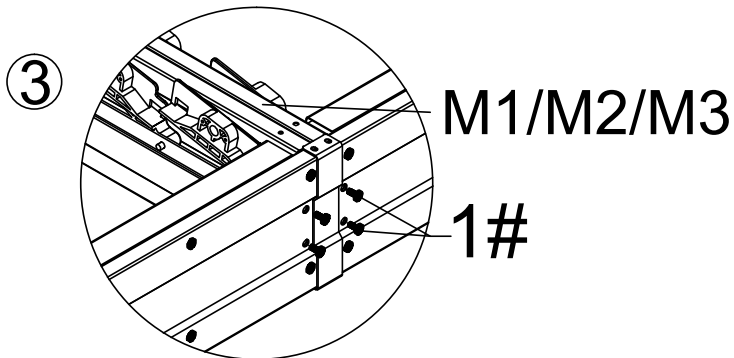
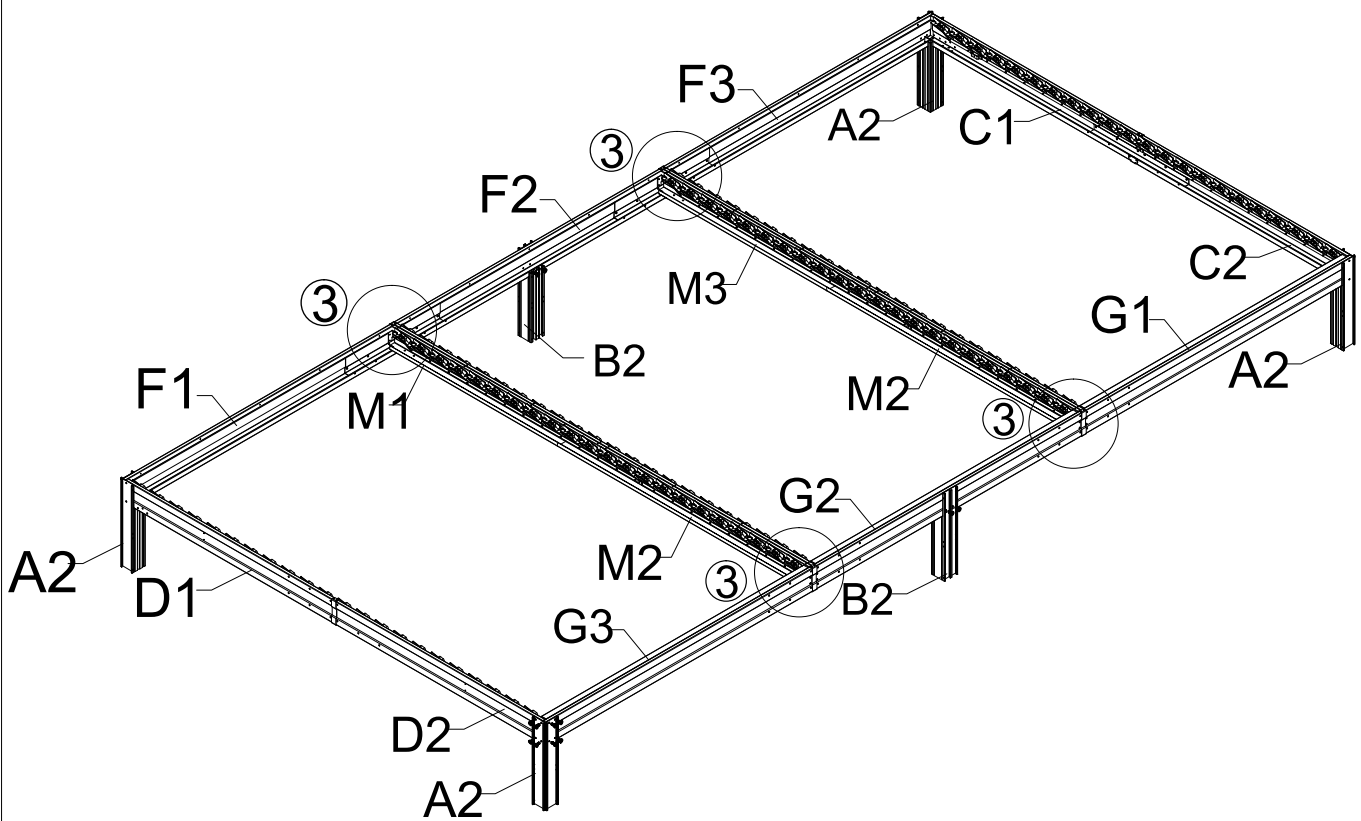

Use 4 bolts #1 to fix the beam #M1/M2/M3 #as shown.  
Repeat above procedures to assemble the other 3 sides.

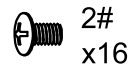
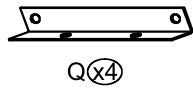

M1/M2/M3

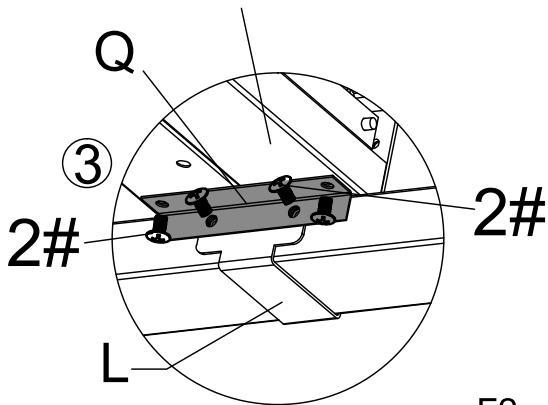

Bottom View

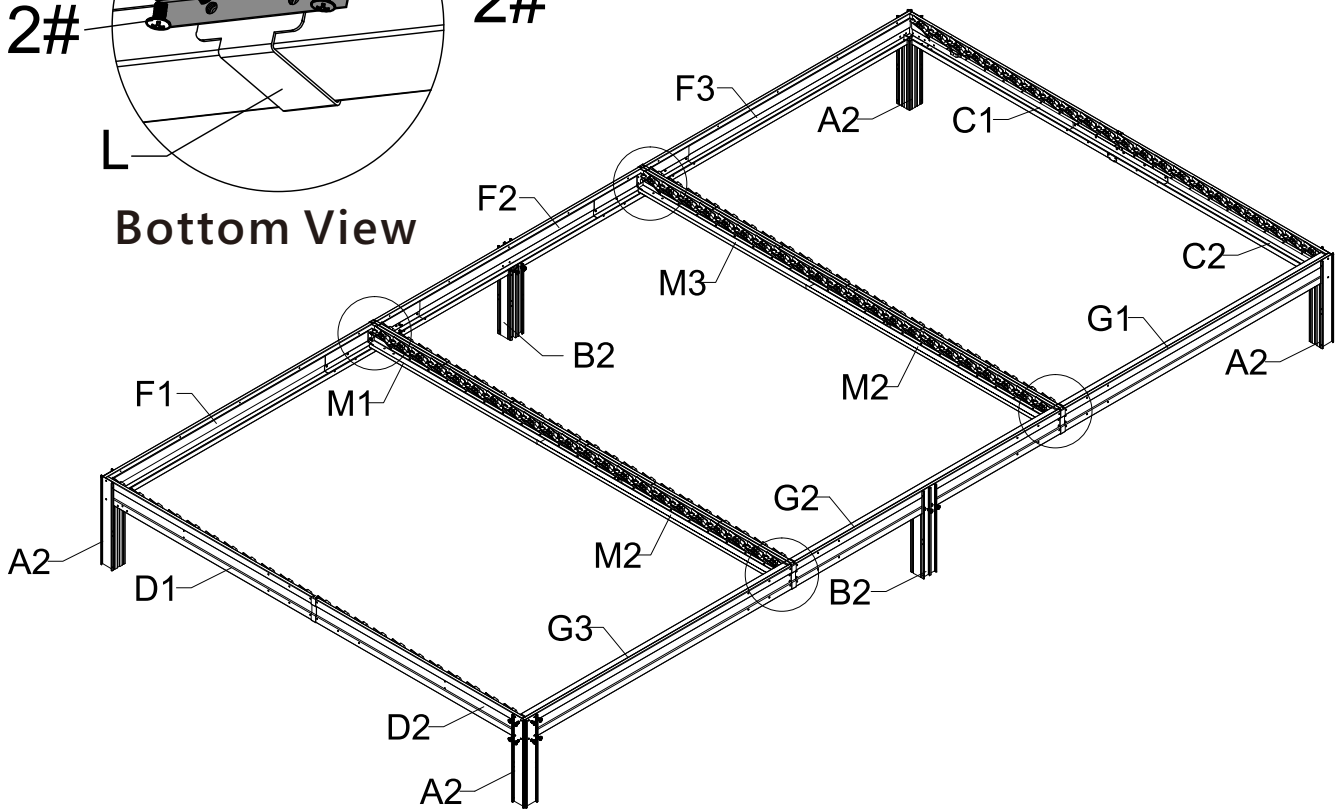

③: Use 2 bolts #2 to secure the connector #Q to the beam as shown.

Place the beam #M1&M2, #M2&M3 onto the connector #Q, align the holes and secure with 2 bolts #2.

Repeat above procedures to assemble the other 3 sides.

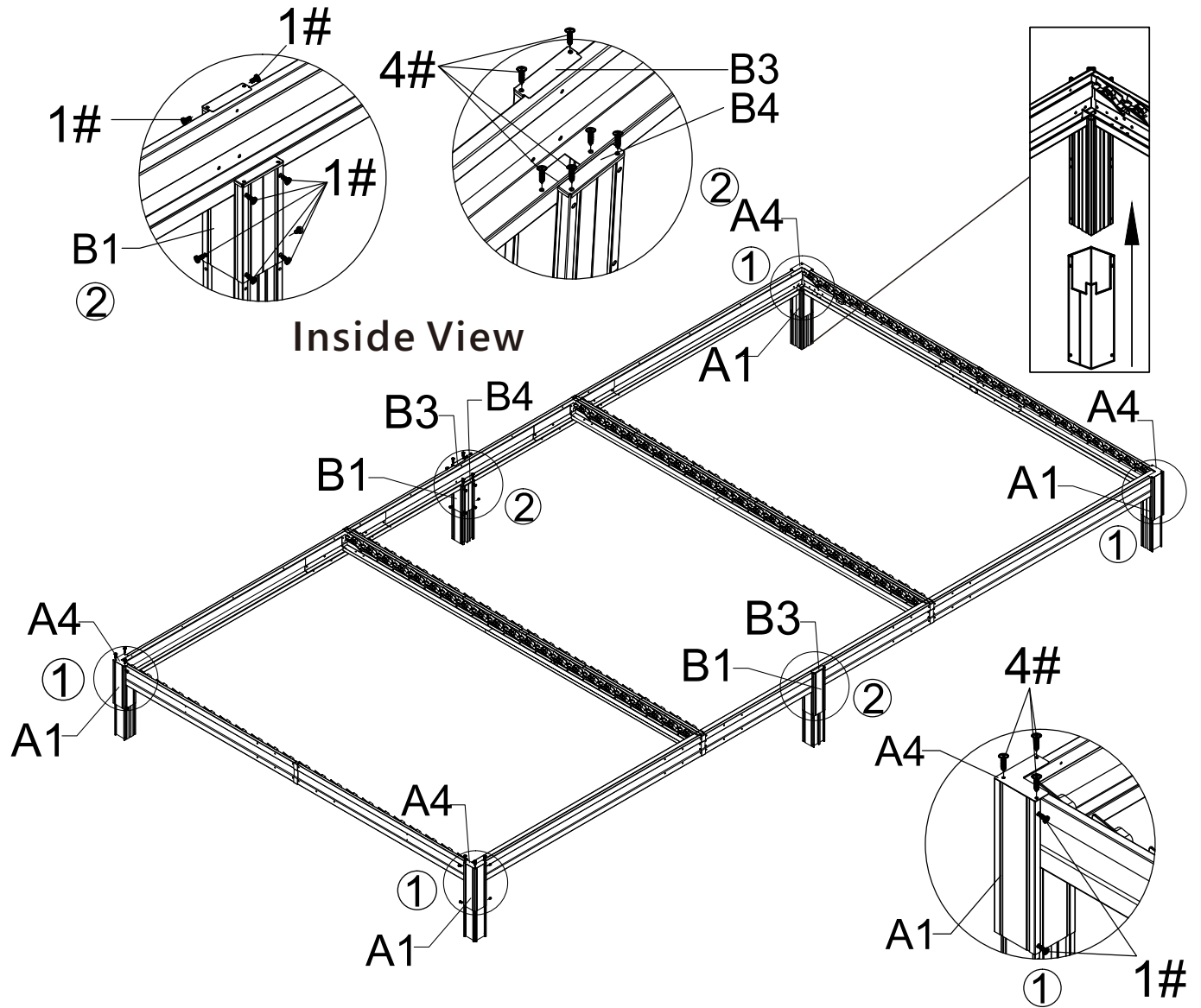
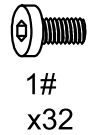
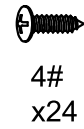
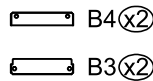
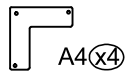
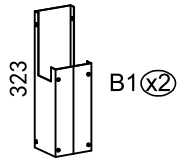
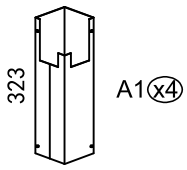

Slip over #A1 to the connector #A2 as shown.  
 Use 3 screws #4 to secure cover #A4.  
 Use 4 bolts #1 to secure #A1 to the connector #A2.  
 Repeat above procedures to assemble the other 3 sides.

Slip over #B1 to the connector #B2 as shown.  
 Use 6 screws #4 to secure cover #B3,B4 and the beam.  
 Use 8 bolts #1 to secure #B1 to the connector #B2.  
 Repeat above procedures to assemble the opposite side.

### Installation Tip:



1#  
x32

To install parts #A and #B, first lay the crossbeam frame on its side (rotate 90° toward #G1-G3). Attach poles to one side (#F1-F3), then flip the frame over to attach poles to the opposite side. Finally, rotate the frame upright.

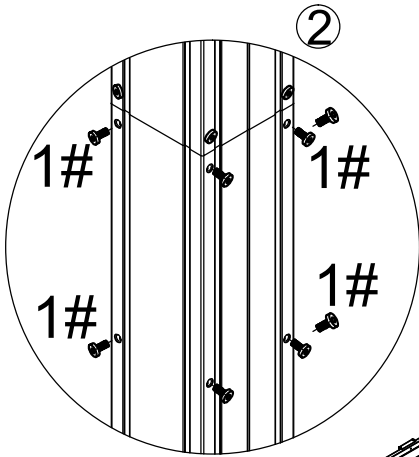

②: Use 8 bolts #1 to assemble pole B.

Repeat above procedures to assemble the opposite side.

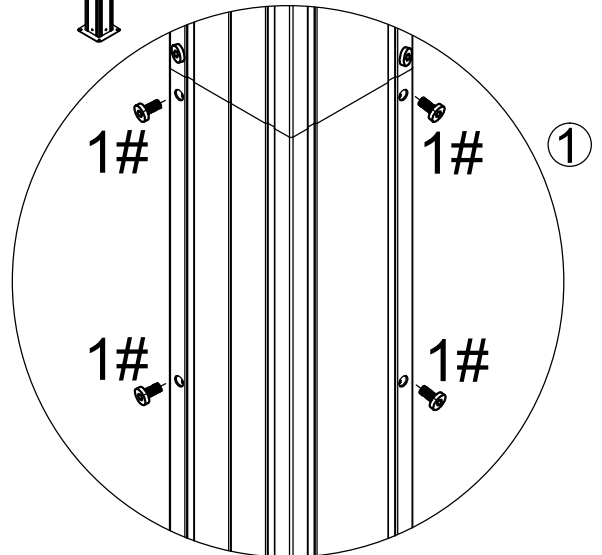
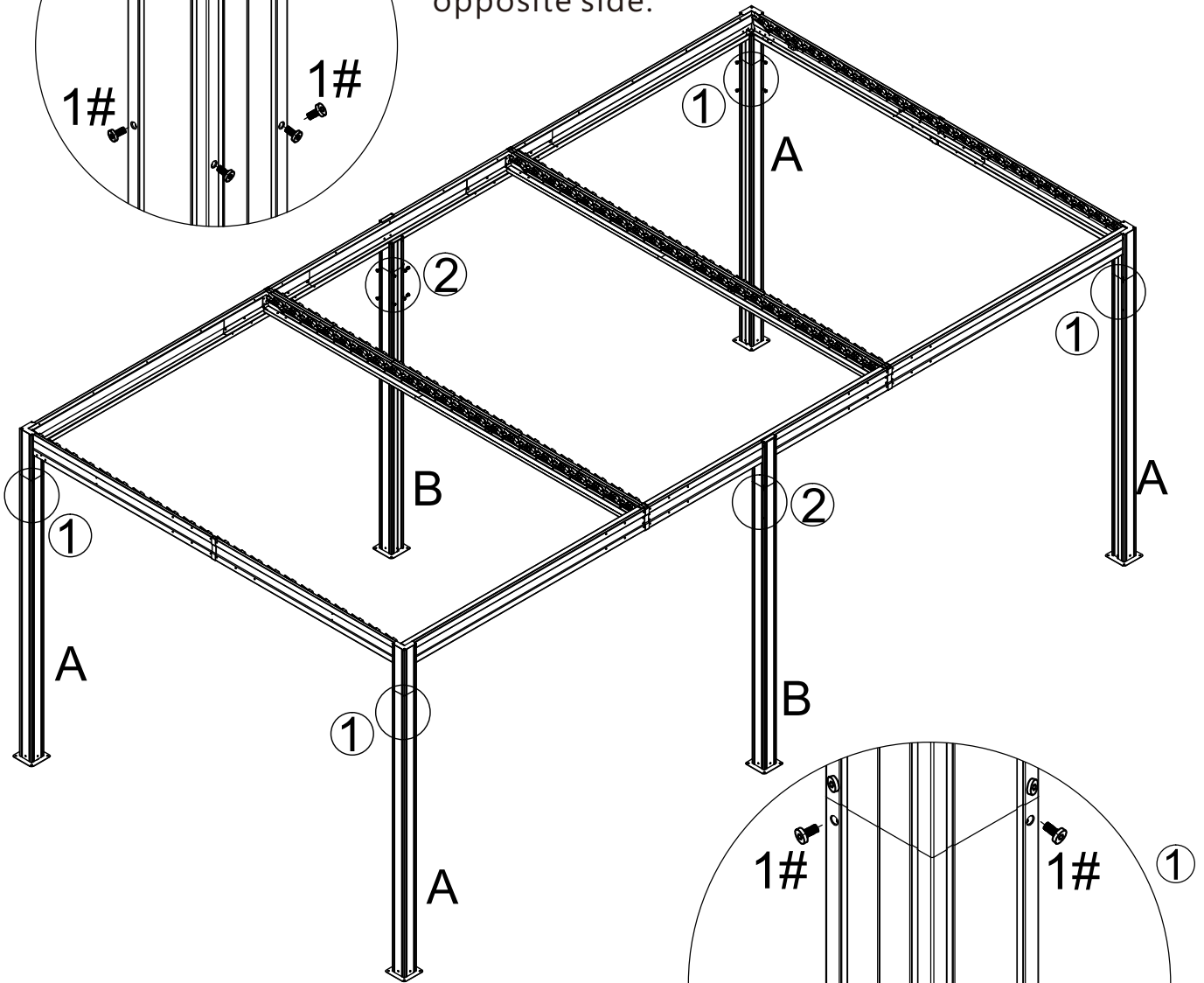

①: Use 4 bolts #1 to assemble pole A.

Repeat above procedures to assemble the other 3 sides.



1937



H(x3)

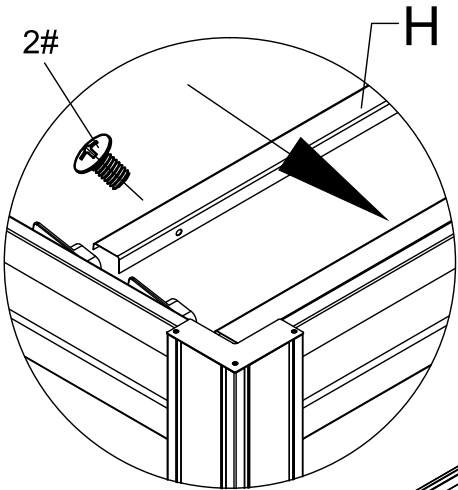
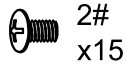

Use 15 bolts #2 to assemble Rain Guard #H to the beam #G1/G2/G3.

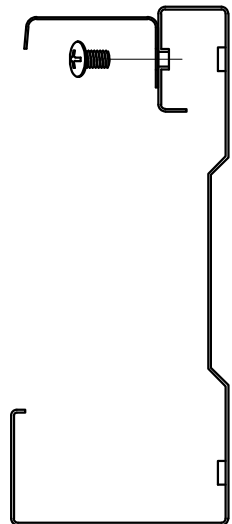
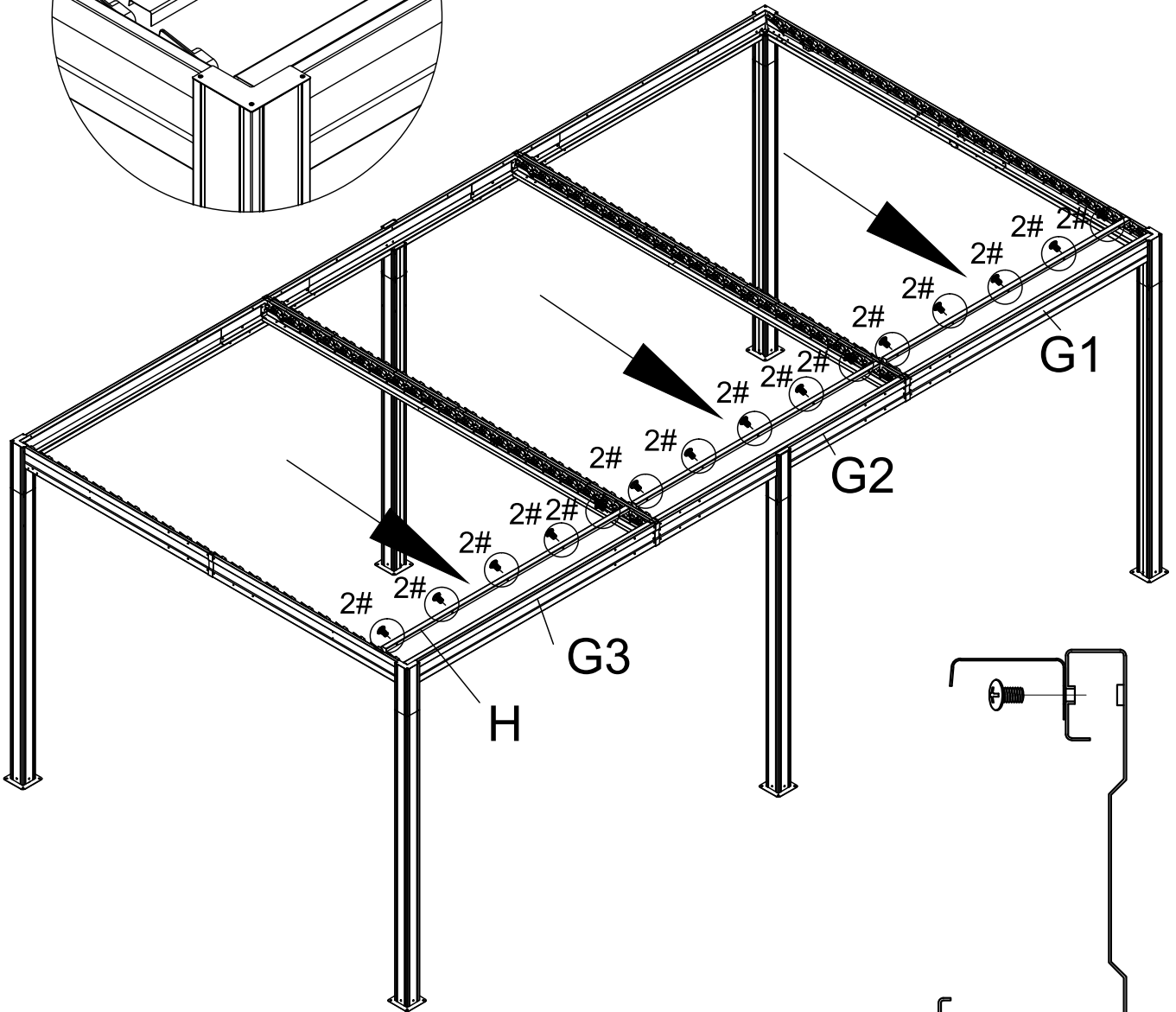

Section View

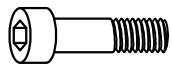
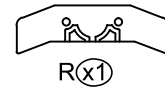
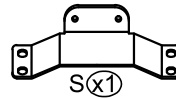
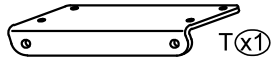
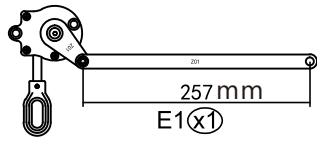
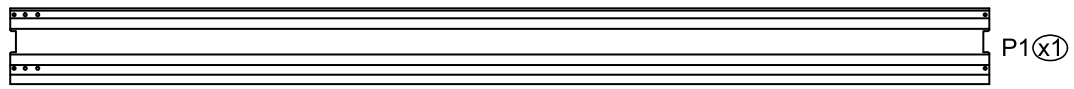

5#  
x2



9#  
x4



10#  
x4



2#  
x4



6#  
x1



7#  
x1

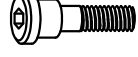

8#  
x1

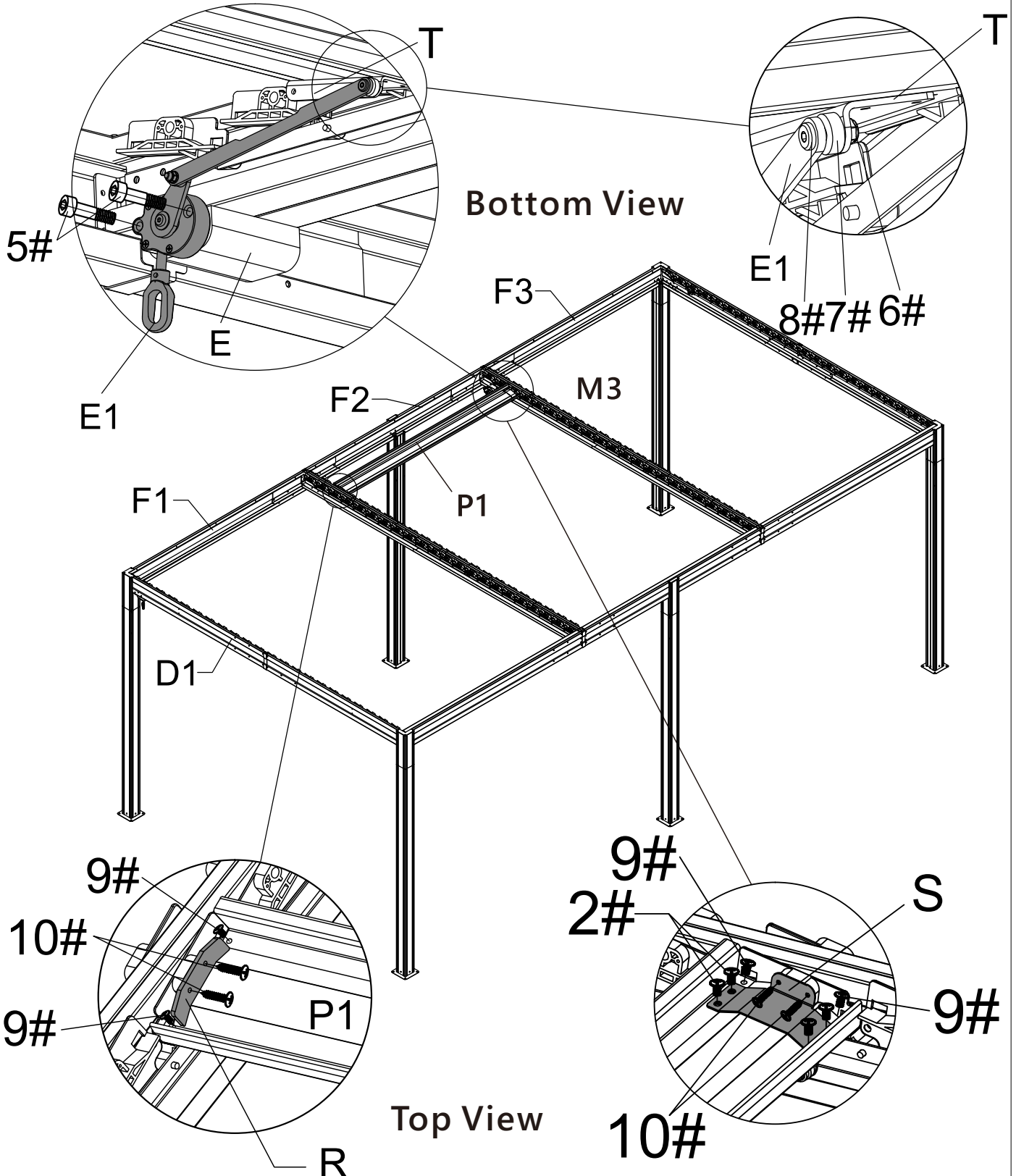

Use 2 bolts #5 to secure part #E1 to #E.

Use 1 Bolt #8 ,plastic gasket #7 and nuts #6 to secure the rod(on #E1) with part #T.

Place the louver panel #P1 on the plastic bracket(already assembled in the linkage rod) as shown, and secure with 2 screws #9 on each side.

Place part #S on the panel #P1, align the holes, use 4 bolts #2 to secure part #S,panel #P1 with part #T. (Clip the panel between part #S and #T.) Use 2 screws #10 to secure part #S to the plastic bracket (already assembled on the linkage rod).

Use 2 screws #10 to secure plastic clips #R to the plastic bracket (already assembled in the linkage rod) on the opposite side.

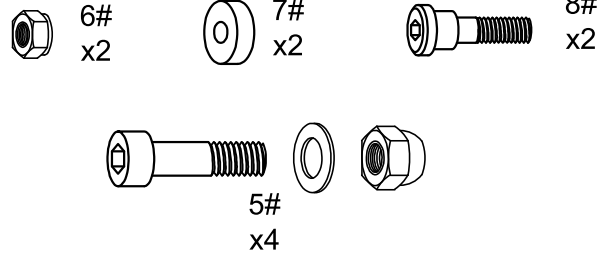
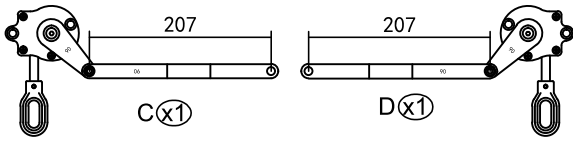

Use 2 bolts, washers and nuts #5 to secure part #C to #K1 (already assembled on beam #C1).

Use 1 Bolt #8, plastic gasket #7 and nuts #6 to secure the rod (on #C) with linkage rod.

Repeat above procedures to assemble part #D to #K2 (already assembled on beam #D1).

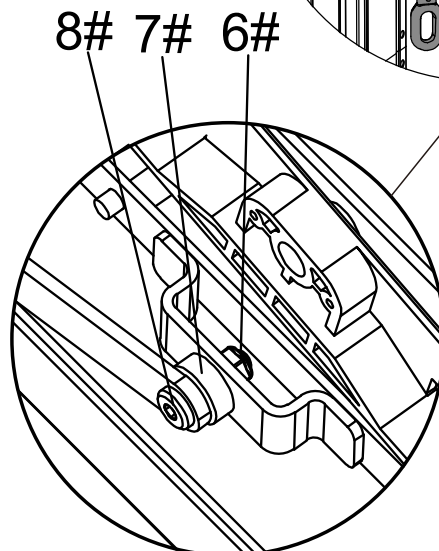
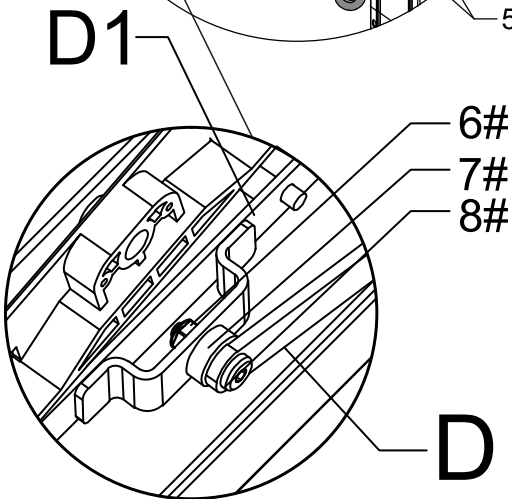
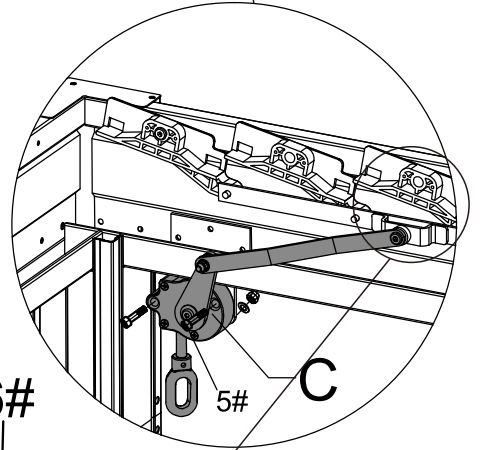
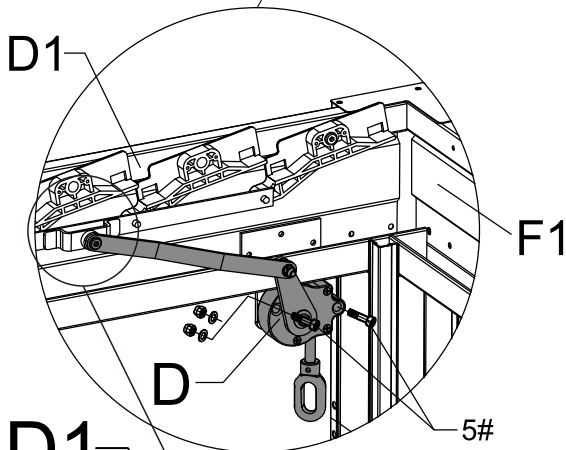
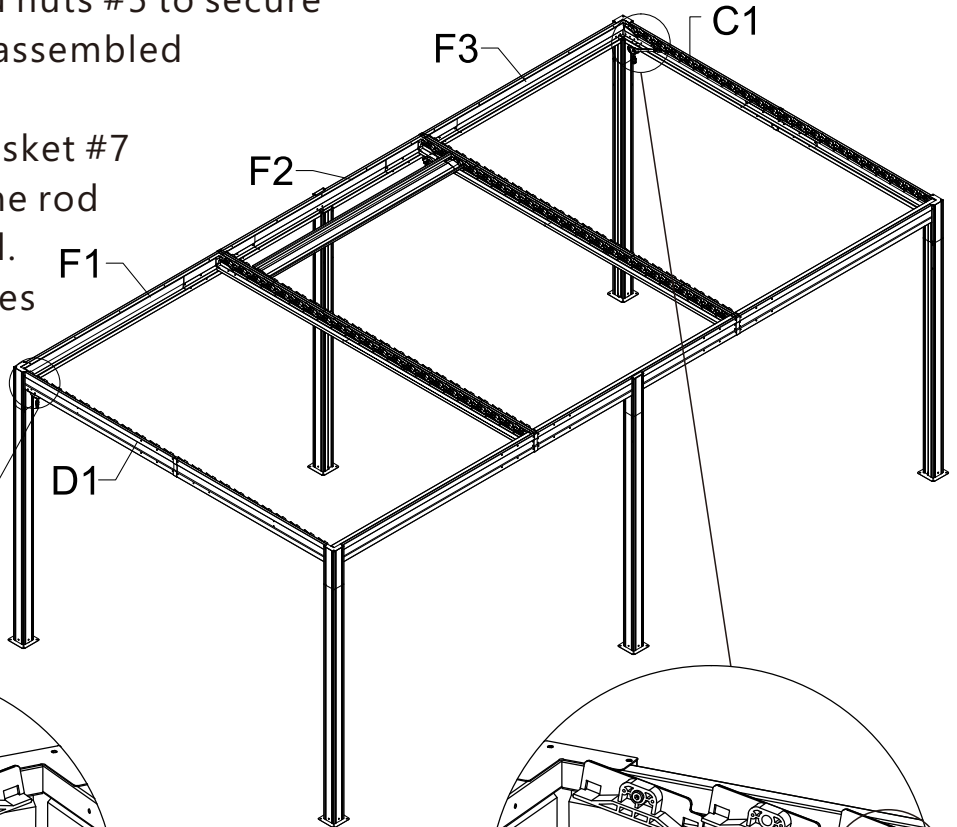

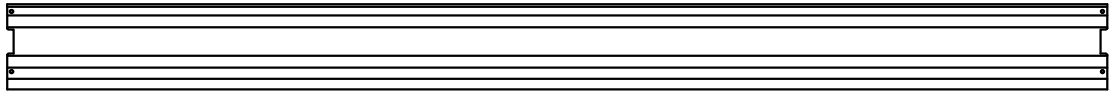

P(x65)



R(x130)



9#  
x260



10#  
x260

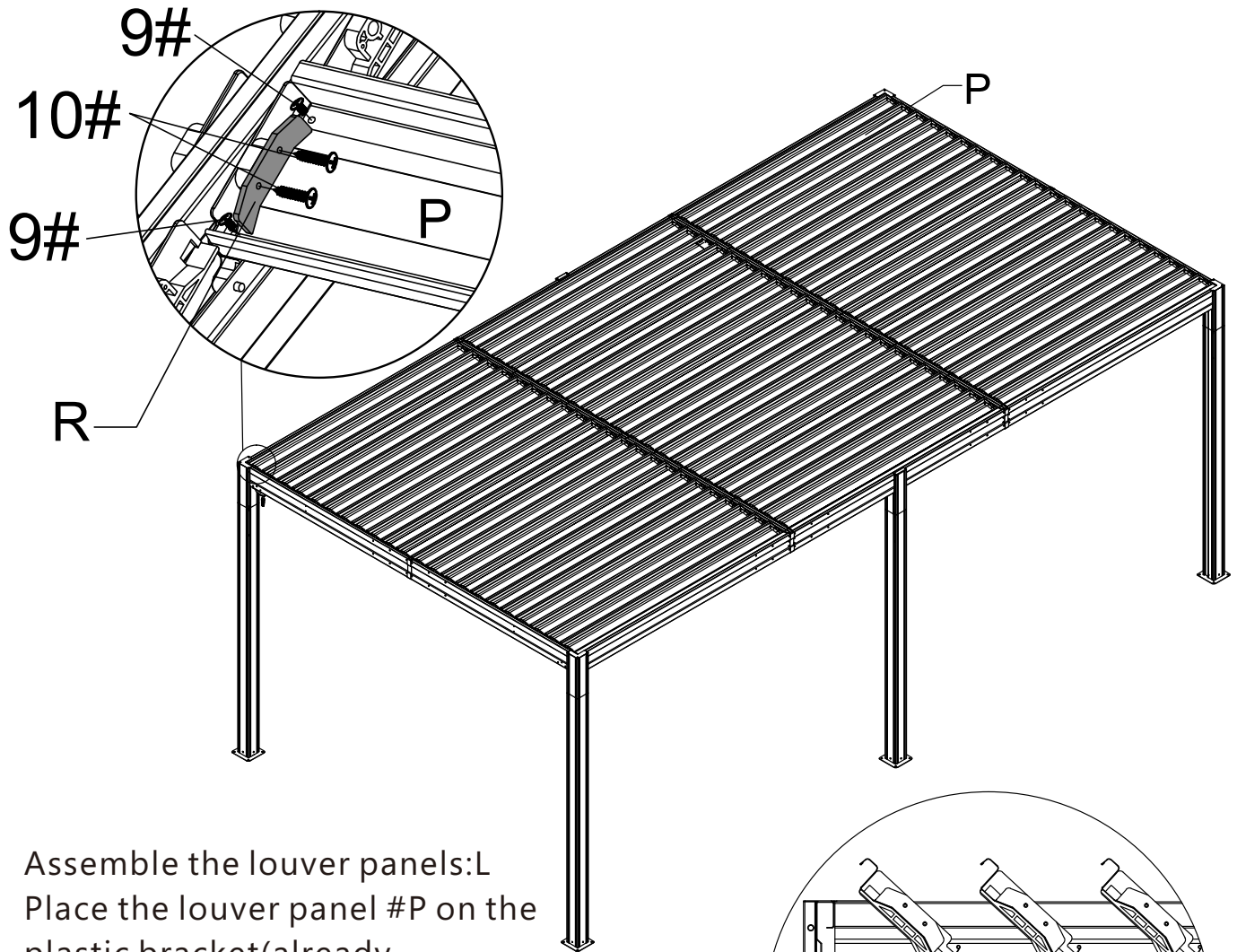

Assemble the louver panels:  
Place the louver panel #P on the plastic bracket (already assembled in the linkage rod), and secure with 2 screws #9 on each side. Use 2 screws #10 to secure plastic clips #R to the plastic bracket (already assembled in the linkage rod) on each side. Repeat above procedures to assemble the remained louver panels.

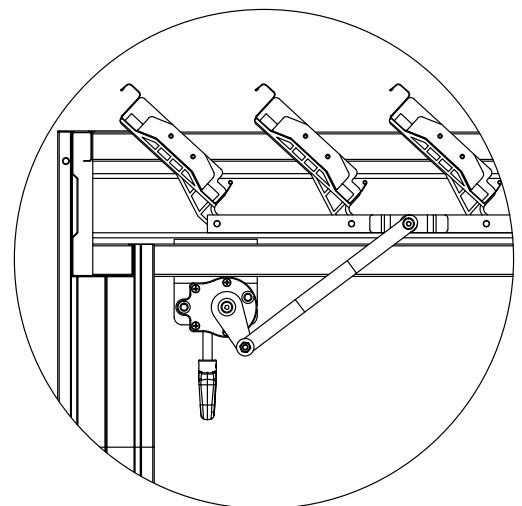

Installation Diagram of louver panels.

Notice: Open the louvers to prevent snow accumulation when moderate to heavy snow is forecast.

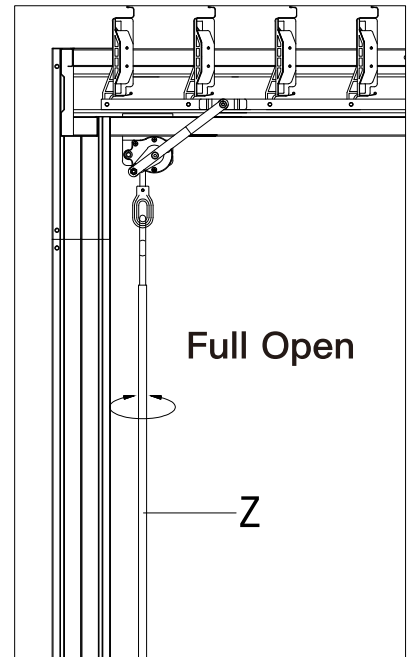
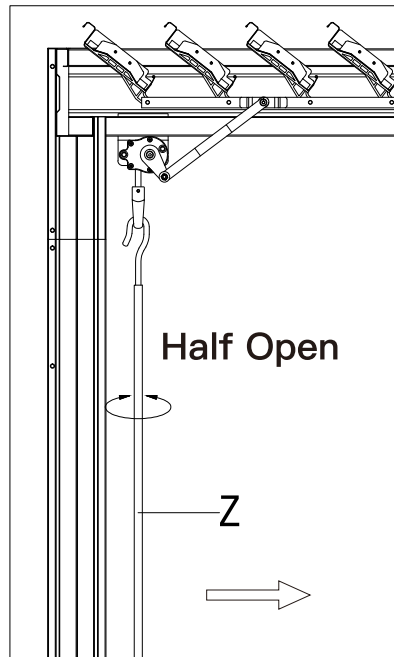
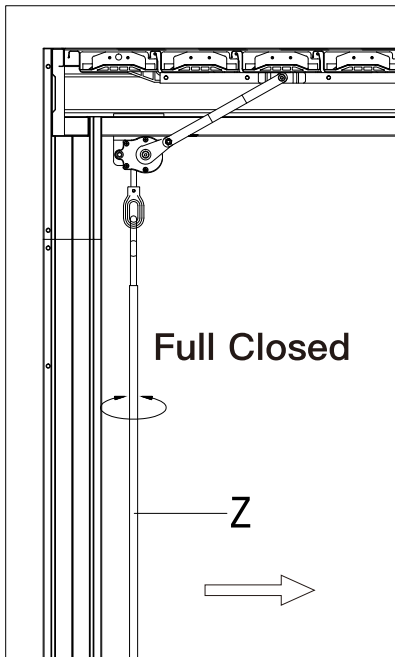

Just shake the roller rod anytime you want let the sun in or block the sunray. If moderate to heavy snow is forecast, pls open the louvers to avoid snow accumulating.



(ATTENTION: Louvers can be opened and closed in cycles.)

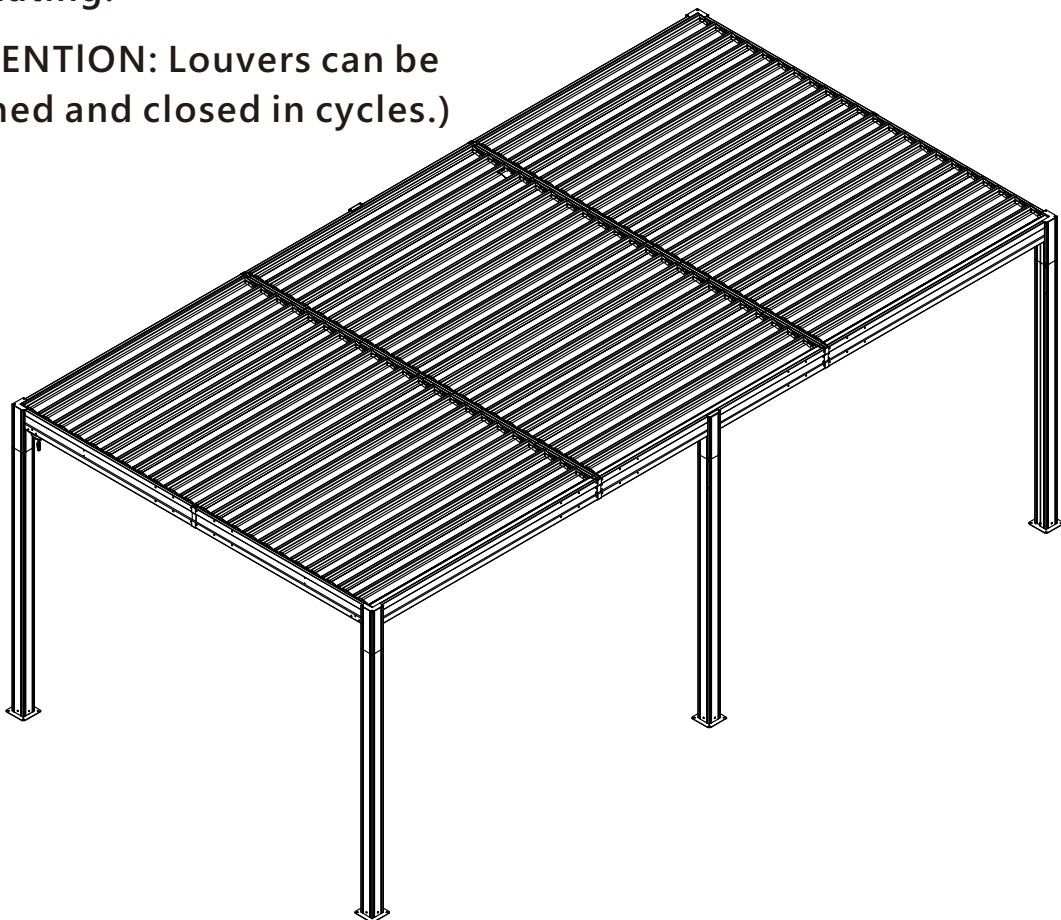

Please confirm the louvers can be fully closed for waterproofness.



## Thanks for your purchase.

At domi outdoor living, we believe in our products.

That's why we provide a 12-month warranty and friendly, easy-to-reach after-sales service. So, if you have any questions about our product or assembly, please feel free to contact us. We are here for you.

**Support:**



**After-sales contact email:**

[service@domioutdoorliving.com](mailto:service@domioutdoorliving.com)

**Business cooperation contact email:**

[marketing@domioutdoorliving.com](mailto:marketing@domioutdoorliving.com)

Please have your order ID available if you reach out for support.

If you have damaged parts or product, please send us photos for an immediate response.