



Assembly Instructions



Caution: You must read this before you proceed

Bar Cart

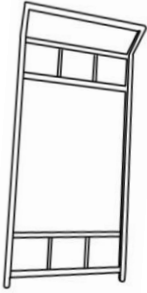

Parts List

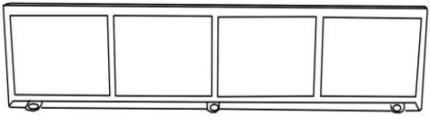
Label	Picture	Description	QTY
A		Right Frame	1
B		Lef Frame	1

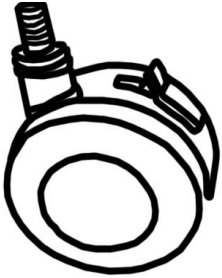
C		Side Frame	4
D		Glass	2
E		Wheel	2
F		Wheel with Brake	2

Hardware

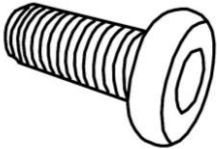
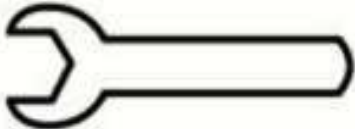
Label	Picture	Description	QTY
①		Allen Key(M6)	1
②		Bolt(M6*15MM)	18
③		Spanner(M10)	1

④



Glass Suction Cup

14

Assembly Preparation

Before Beginning Assembly:

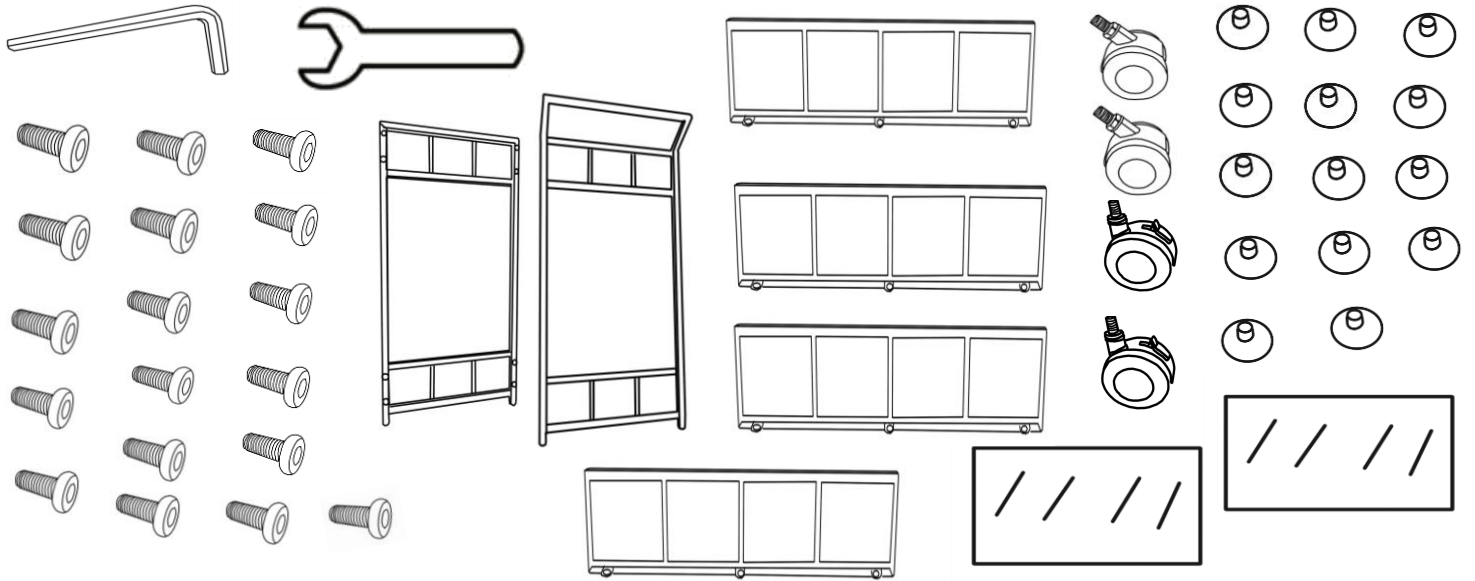

• Read instructions, cover to cover-



• Have 2 adults on hand for assembly-



• Do not assemble on flooring or carpet-



• Assemble on a clean non-marring surface (packing foam)-



• Save all packaging until finished-

Assembly Steps

Overview

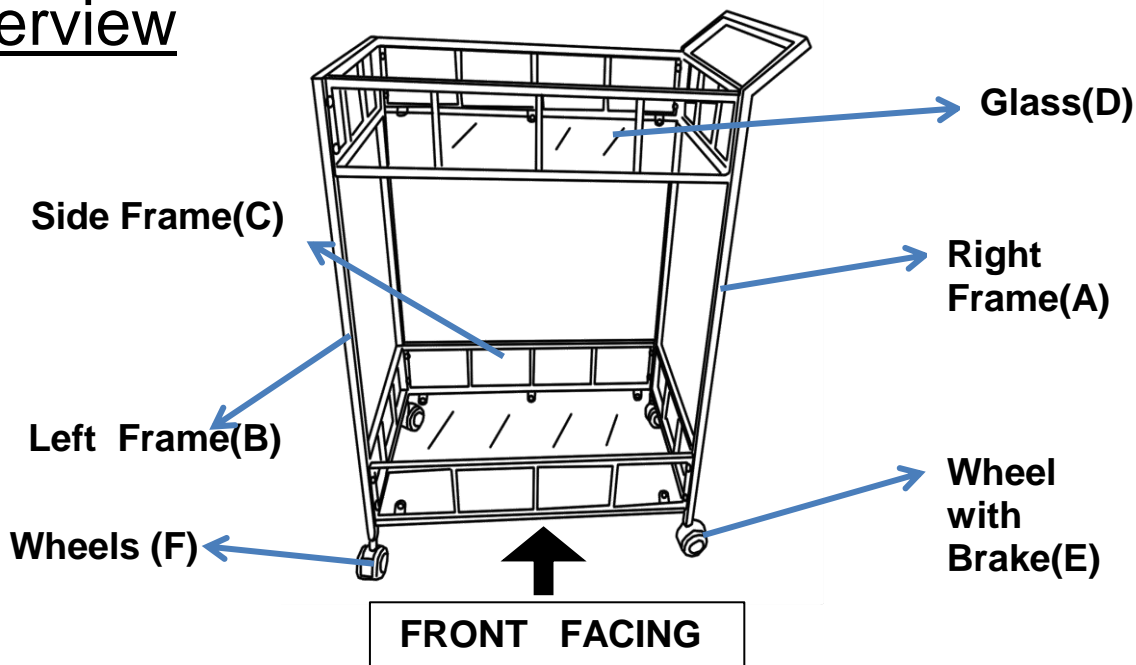

This Bar Cart has multiple parts and may require up to some 30 minutes to assemble.

To give you an overview of the Bar Cart parts, the above picture is to help you put the various parts into perspective.

Please read through the instructions herebelow to familiarise the parts and steps before assembly.

Step 1

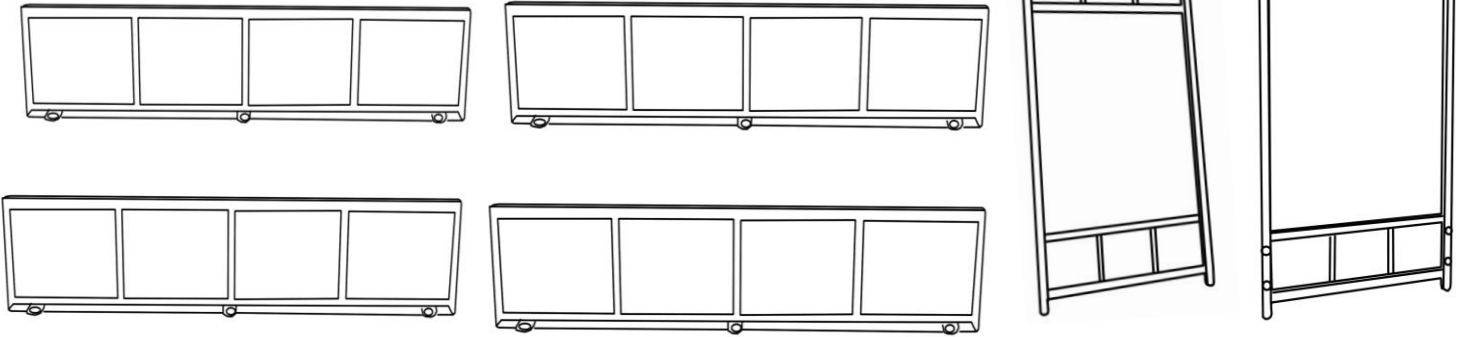

Unpack all parts and place on a clean, non-marring surface.

Step 2

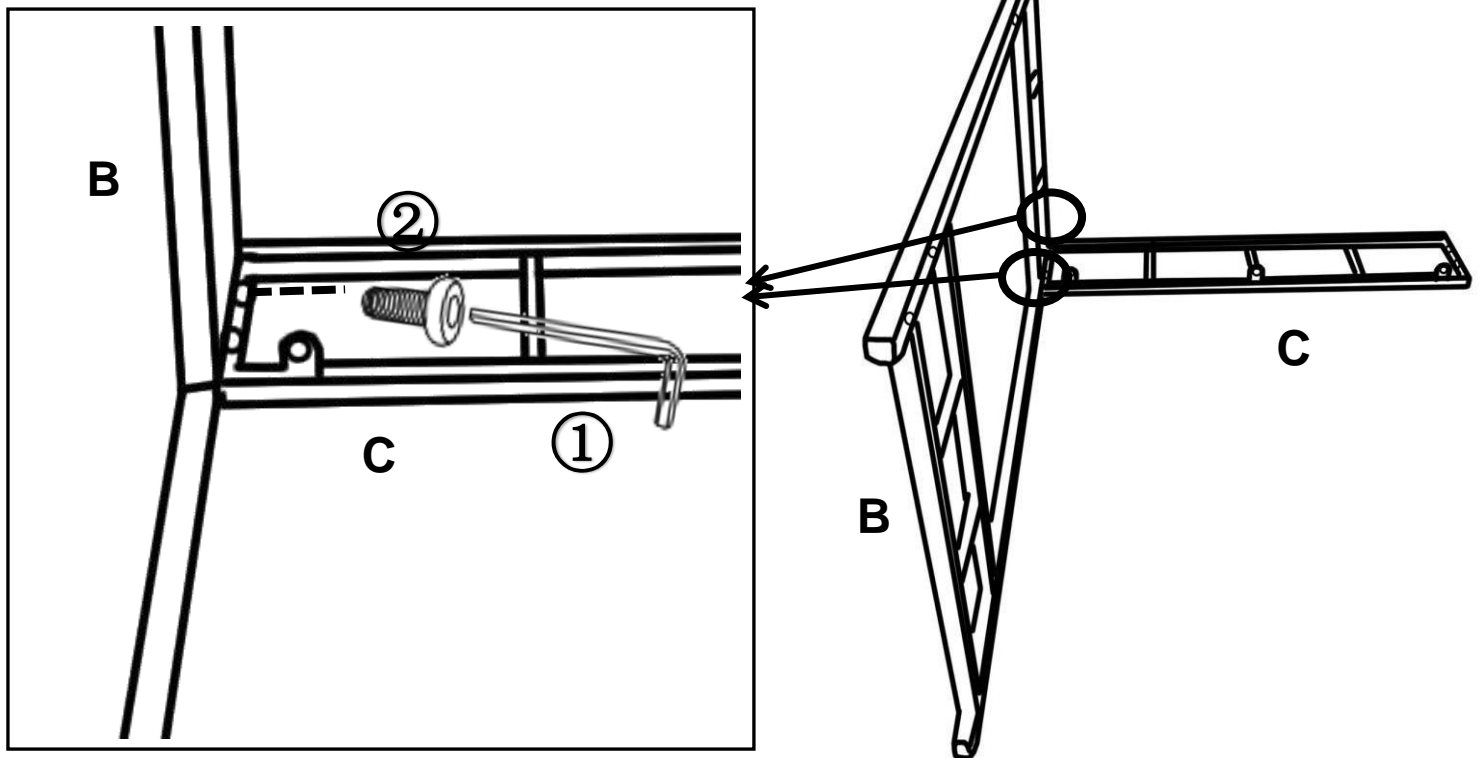

Attach Side Frame(C) to the Left Frame(B) using Bolt(②) with Allen Key(①).
Loosely tighten the Bolts.

Step 3

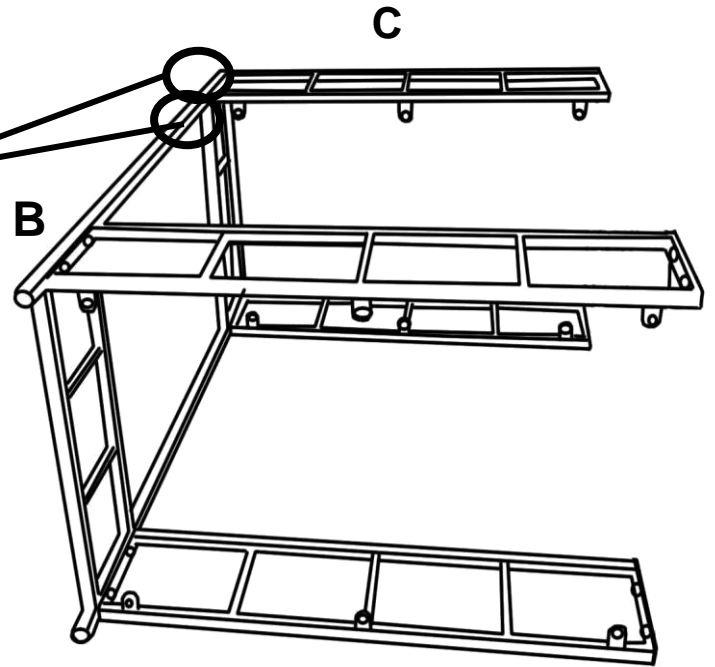
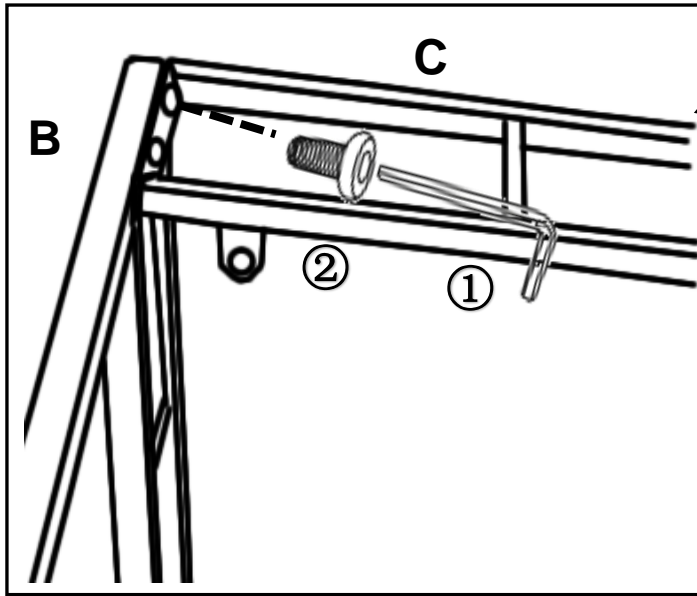

Repeat Step 2 to assemble rest Side Frame using Bolt(②) with Allen Key(①).
Loosely tighten the Bolts.

Step 4

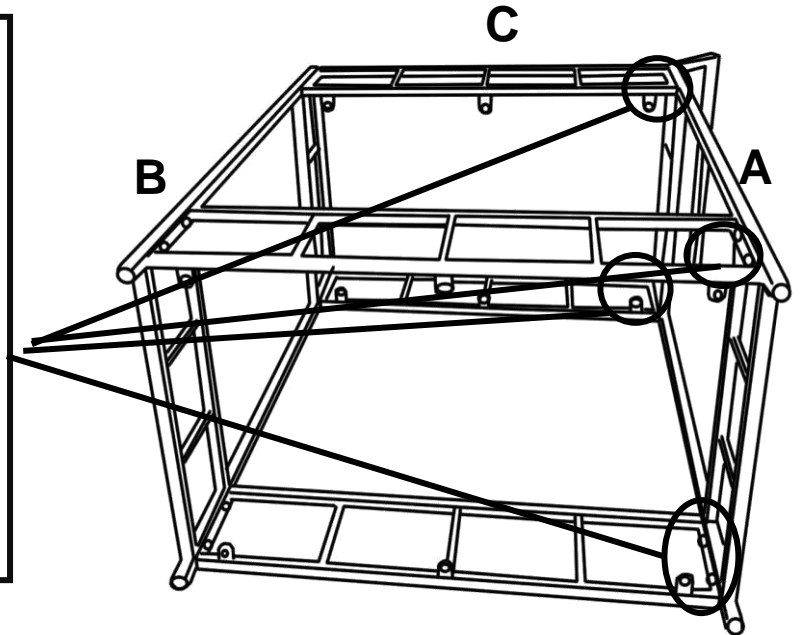
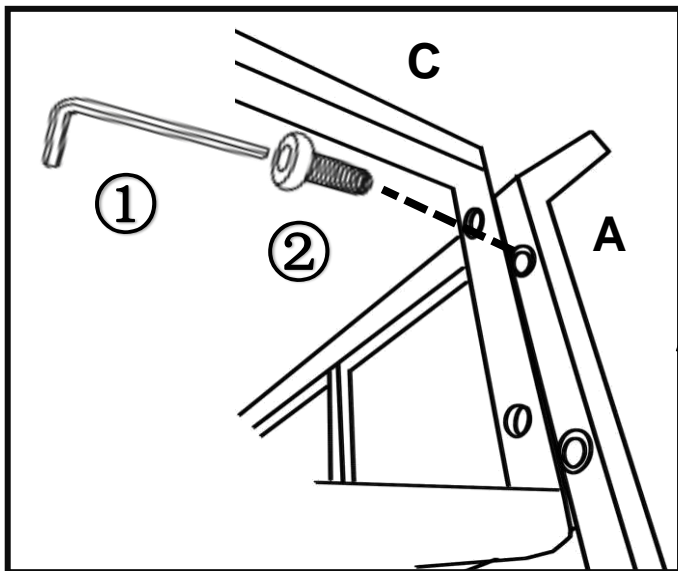

Attach Right Frame (A) to Side Frame(C) using Bolt(②) with Allen Key(①).
Loosely tighten the Bolts.

Step 5

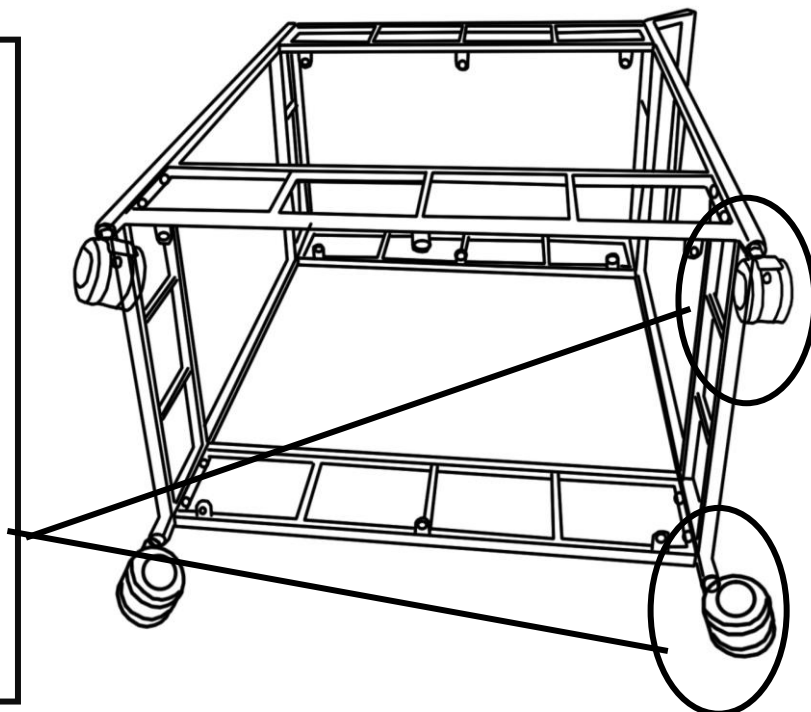
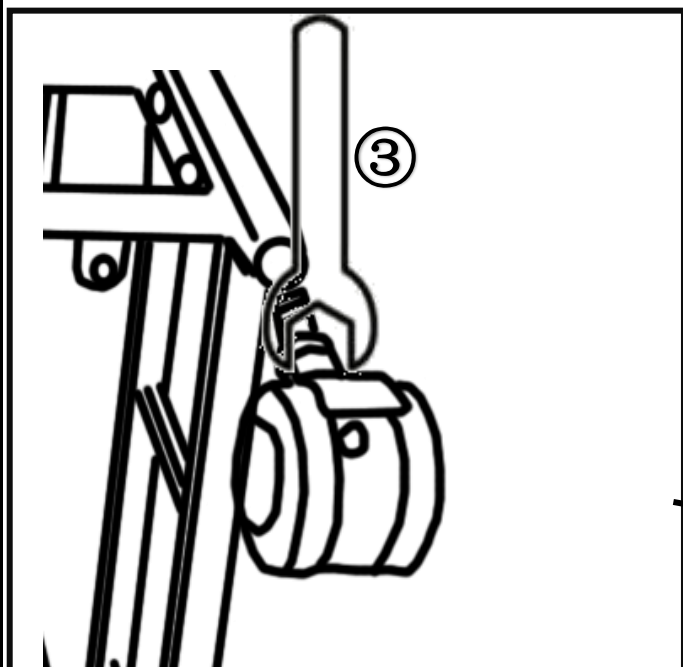

Attach Wheel with Brake (F) to Right Frame(A) using Spanner(③).

Step 6

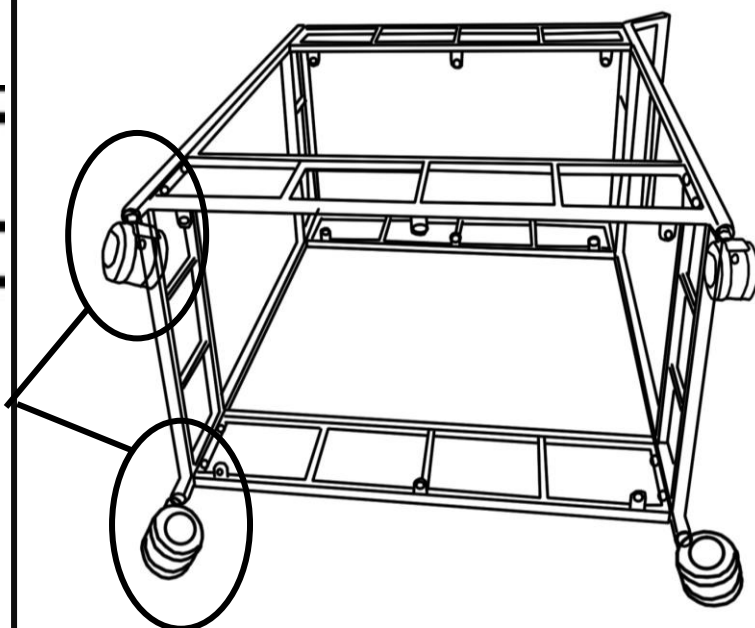
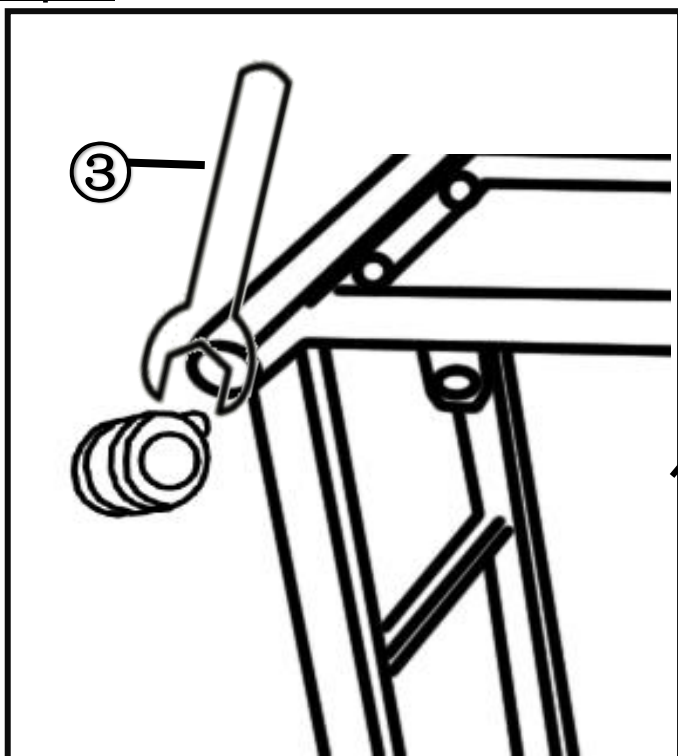

Attach Wheel(E) to Left Frame(B) using Spanner(③).

Step 7

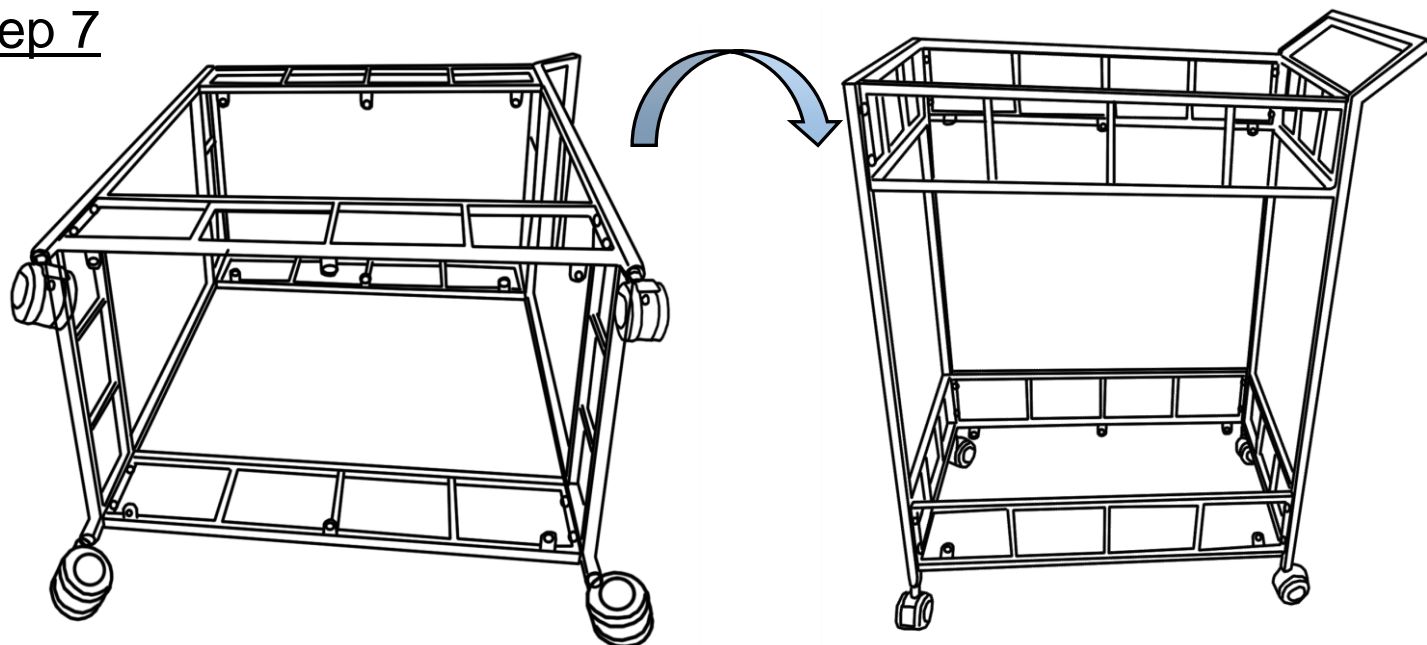

Turn the Bar Cart right side up.

Step 8

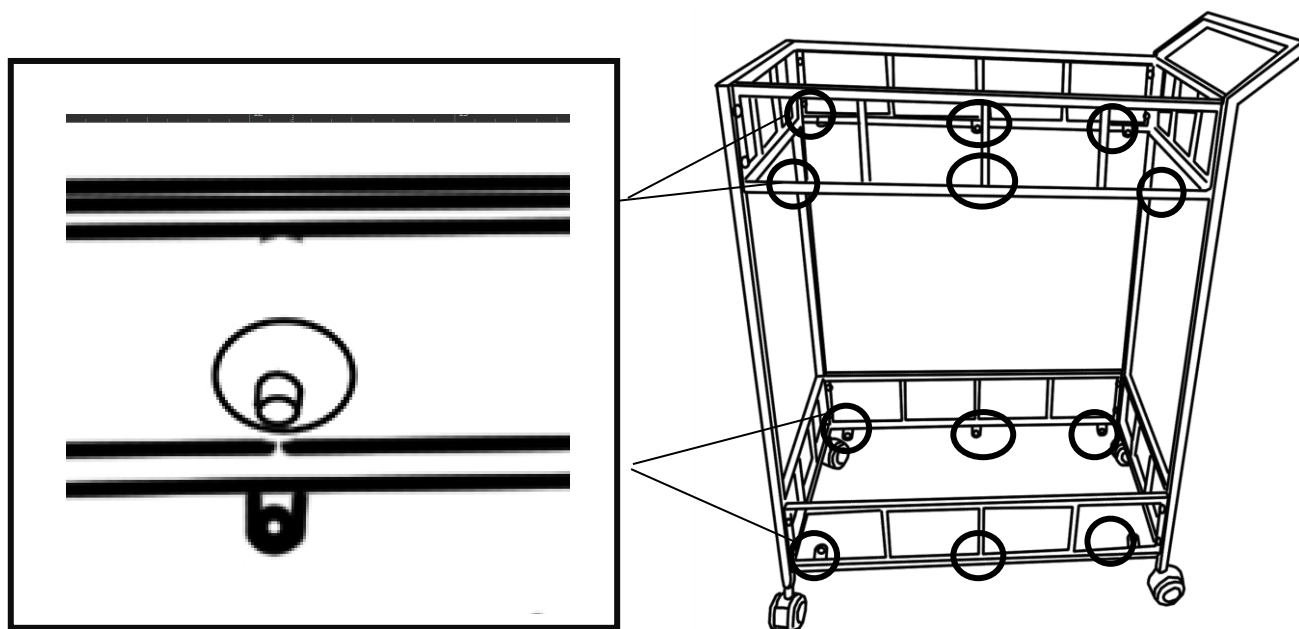

Attach Glass Suction Cup (④) to Side Frame(C) as shown.

Step 9

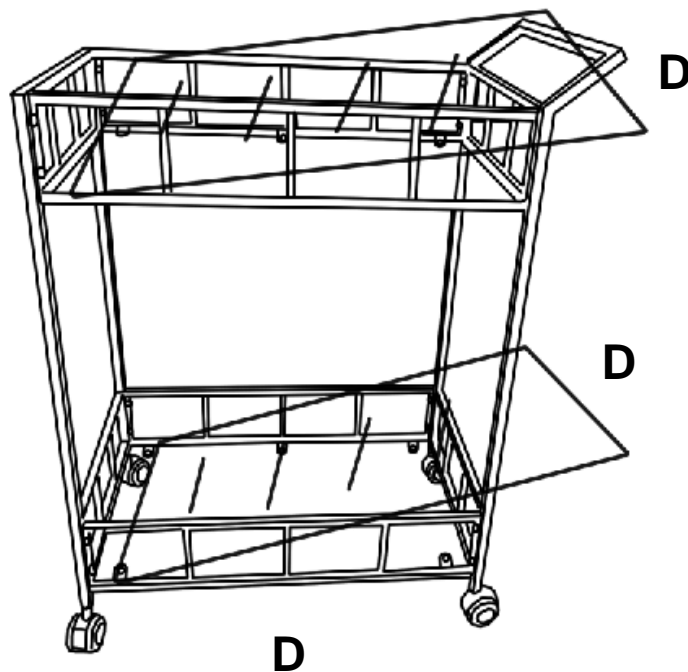

Attach Glass (D) to Side Frame (C).

Remind: Gently press the glass after you put it into the frame.

Please pressure down on each corner to adjust the gap between glass and frame.

Then, Tighten all bolts at all joints fully in a sequential manner.









Step 10



Your Bar Cart is ready for use.

This Bar Cart can only be used on a flat ,level surface.

Care & Maintenance

- ⊘  • Do not put hot items directly on furniture surface.
 - ⊘  • Do not clean furniture with harsh cleansers or polish.
 - ✓  • To obtain the longest lifespan of your outdoor products, minimizing exposure to direct sunlight is recommended.
 - ⊘  • Children should not climb or jump on the furniture.
 - ⊘  • Do not write on furniture without a padded barrier to protect the surface.
 - ✓  • To obtain the longest lifespan of your outdoor products, avoid extended and lengthy exposure to rain, snow, and direct sunshine. Whenever possible cover the product and /or place under patio or awnings.
 - ⊘  • Not for commercial use. For residential use only .
 - ⊘  • Stains may be removed with mild soap solution and damp cloth.
-
- ✓  • Dust and pick-up spills using a clean, non-colored, lint-free cloth .