







ASSEMBLY INSTRUCTION

No	Hardware	Fig	Q.ty
①	Bolt M6x80 mm		4
②	Bolt M6 x 55 mm		8
③	Bolt M6 x 50mm		9
④	Screw M6 x 50mm		12
⑤	Nut M6 x 18mm		8
⑥	Horizontal nut		4
⑦	Allen Key		2



Ⓒx 2 Seat Base

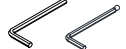
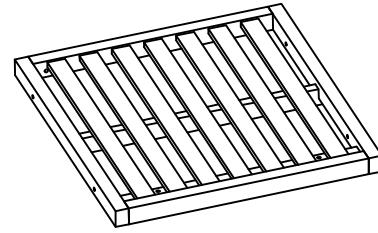
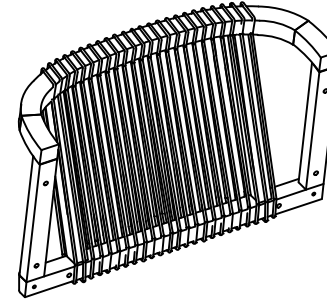

Ⓓx 2 Backrest

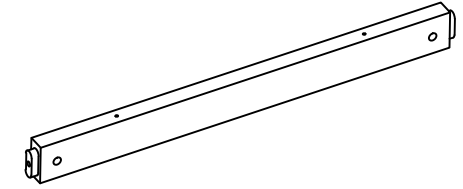

Ⓔx 2 Support Pole

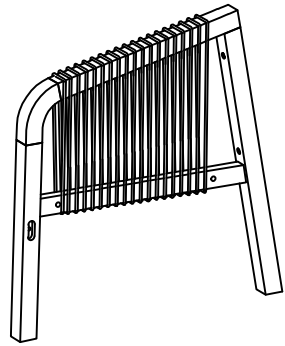

Ⓐx 2 Armrest

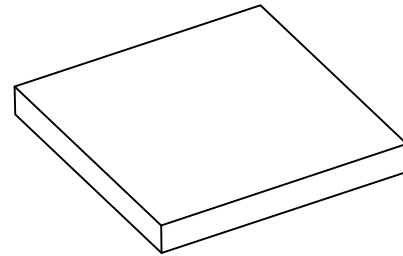

Ⓕx 2 Seat Cushion

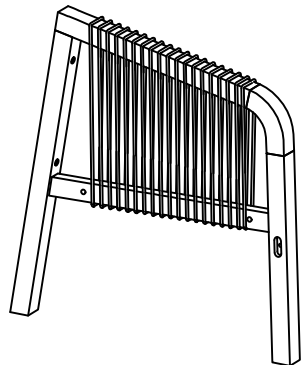

Ⓑx 2 Armrest

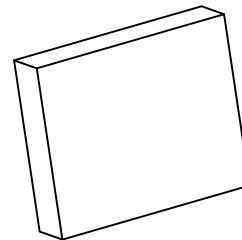

Ⓖx 2 Back Cushion

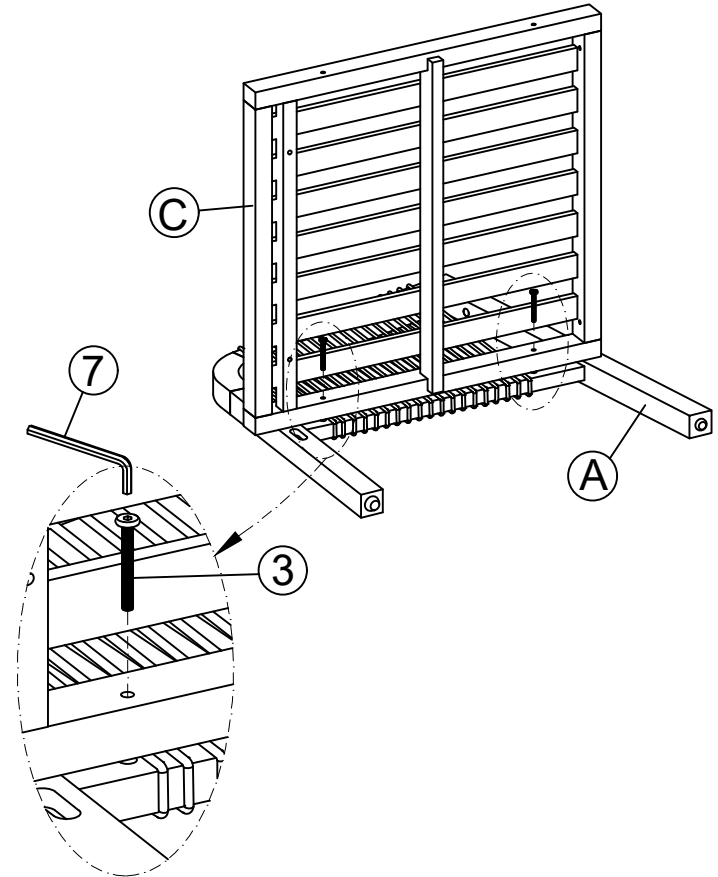

STEP 1

X2

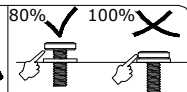
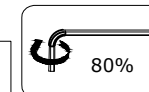

ASSEMBLY INSTRUCTION

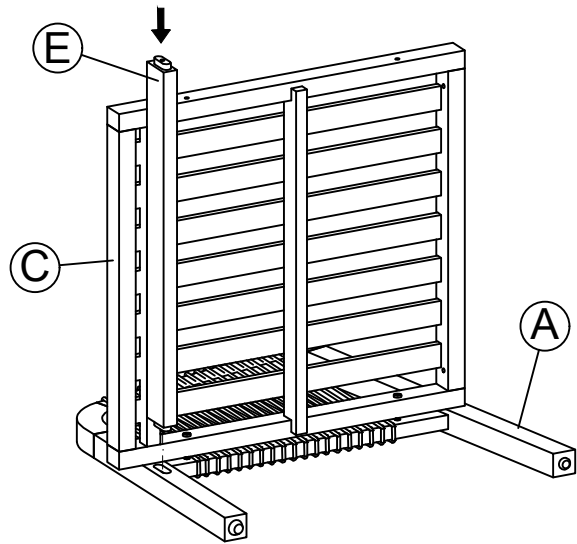

STEP 2

X2

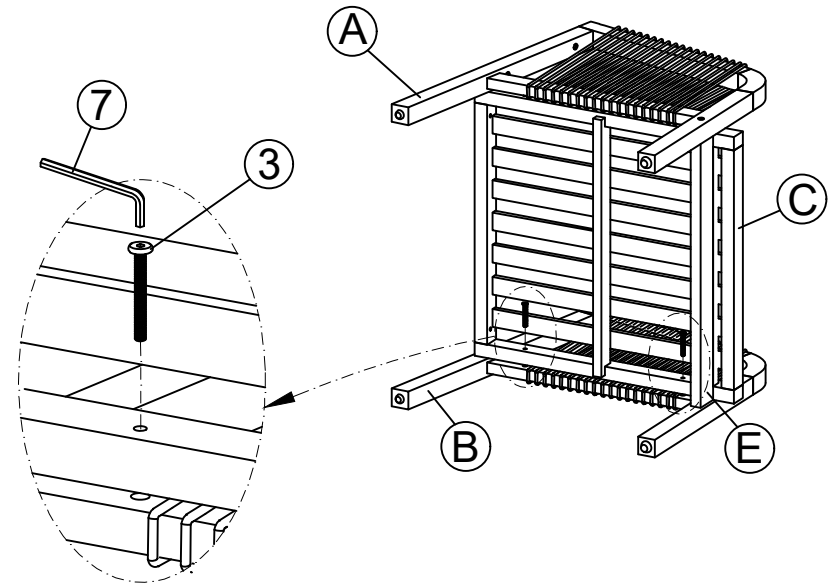

STEP 3

X2

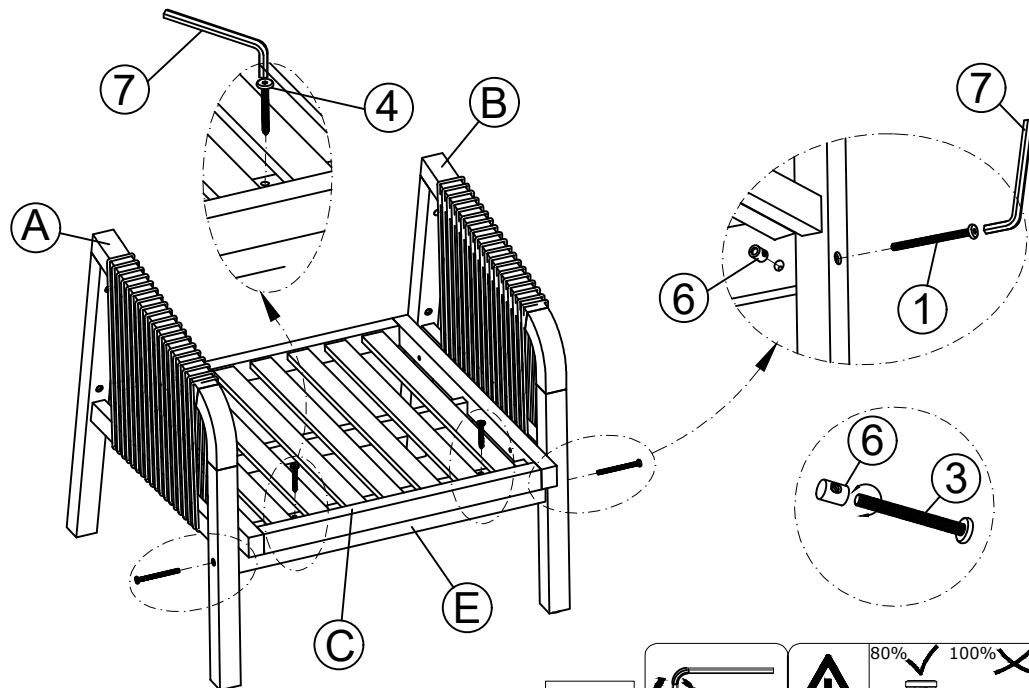

STEP 4

X2

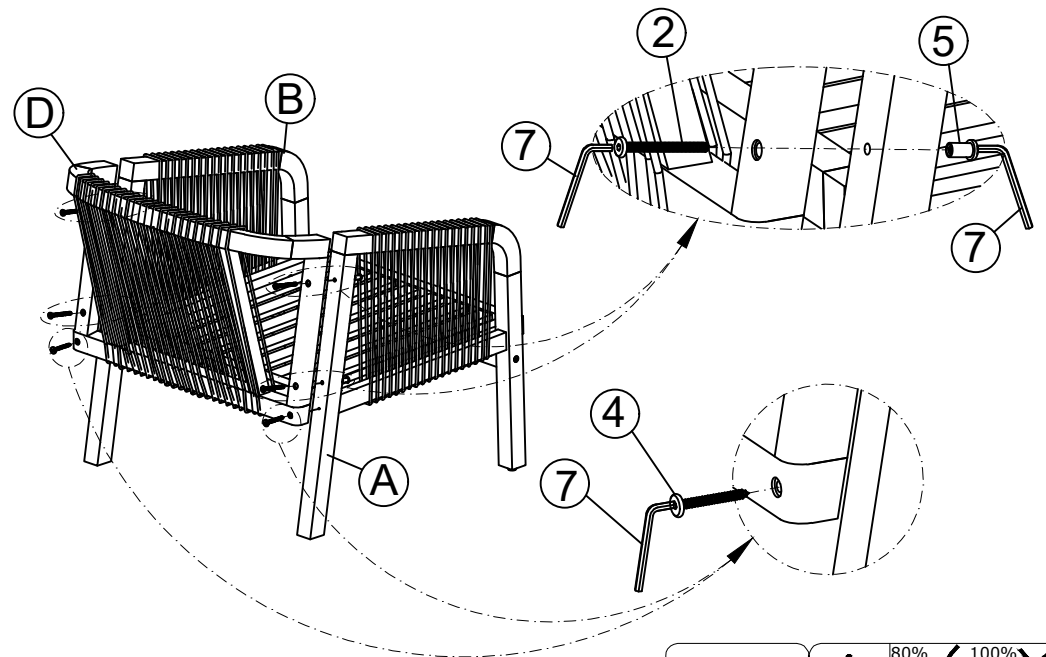

STEP 5

X2



ASSEMBLY INSTRUCTION

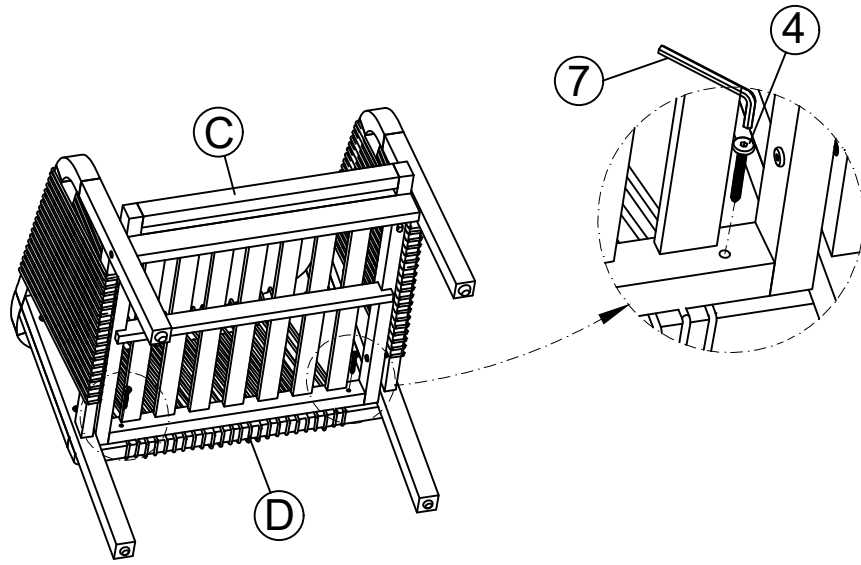

STEP 6

X2

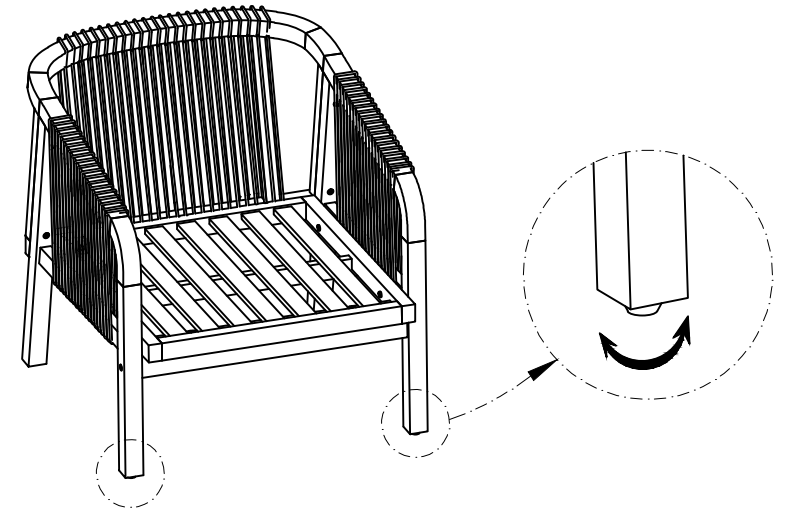

STEP 7

X2

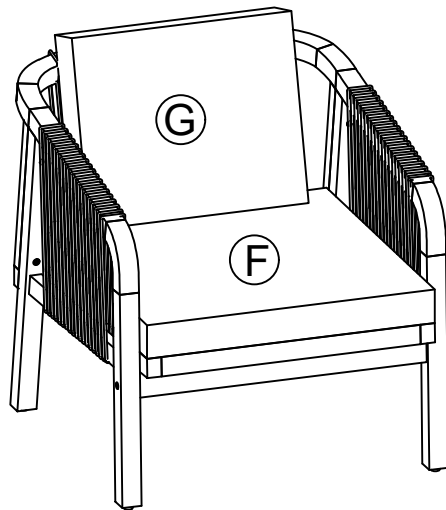

STEP 8

X2

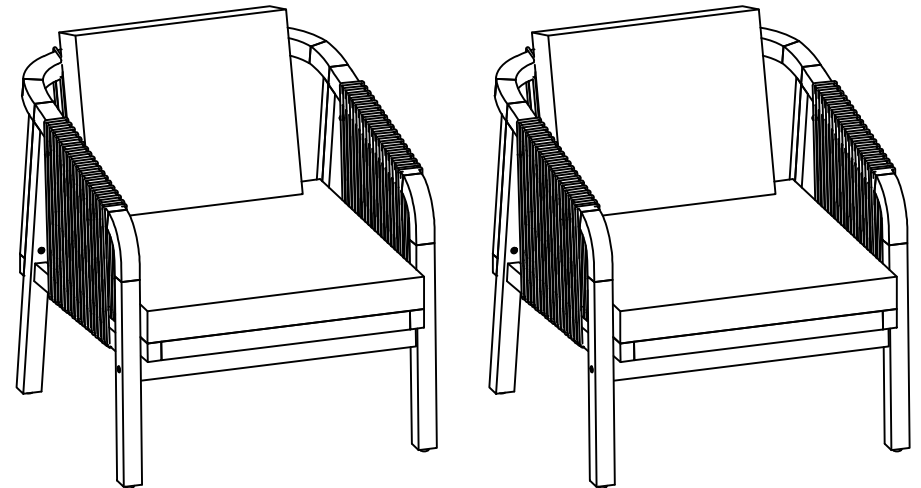

FINISH