





ASSEMBLY INSTRUCTIONS









THANK YOU FOR YOUR PURCHASE!

PARTS AND HARDWARE.

PARTS LIST

No.	DESCRIPTION	IMAGE	Q'TY
P1	SEAT		1
P2	METAL LEGS		2
P3	METAL LEGS		2
P4	METAL LEGS		1

HARDWARE LIST

No.	DESCRIPTION	IMAGE	Q'TY
H1	BOLT (6X16MM)		4
H2	SPRING WASHER (6X10X1MM)		8
H3	FLAT WASHER (6X14X1.5MM)		8
H4	ALLEN KEY		1
H5	BOLT (6X13MM)		4
H6	BOLT (6X25MM)		4

NOTES.

Thank you for purchasing this quality product! Be sure to check all packing material carefully for small part that may have come loose inside the carton during shipping.

CAUTION: Ensure not to overtighten screws to reduce the risk of stripping or breakage.

STEP 1.

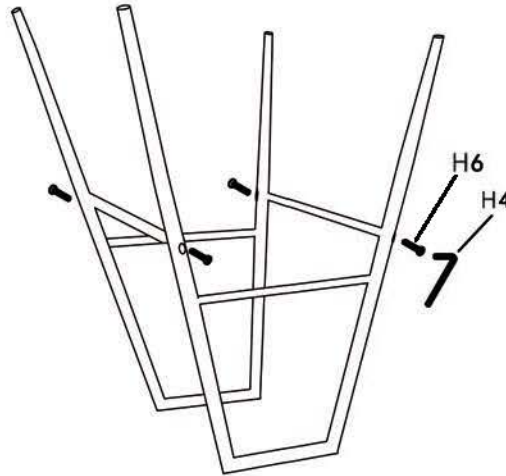

STEP 2.

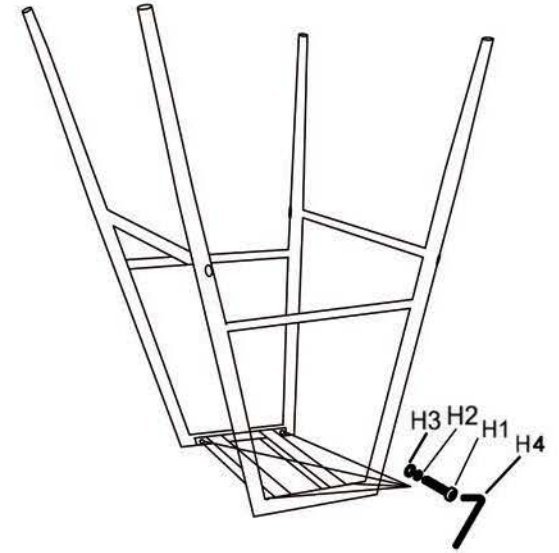

STEP 3.

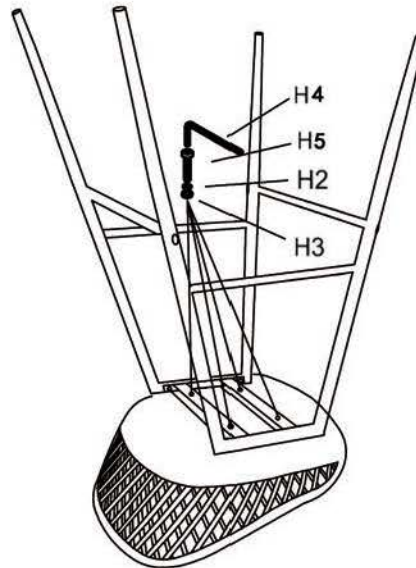

STEP 4.

