







# Instructions for Bifold Full

## HARDWARE

H-LW	WHEELS 	2
H-8	2-1/4" CLEVIS PIN 	4
H-12	3-1/4" CLEVIS PIN 	2
H-5	HAIR PIN 	6
H-11	WOOD DOWEL 	20
H-19	1-3/4" WOOD SCREW 	28
H-34	3/4" WOOD SCREWS 	4

## PARTS

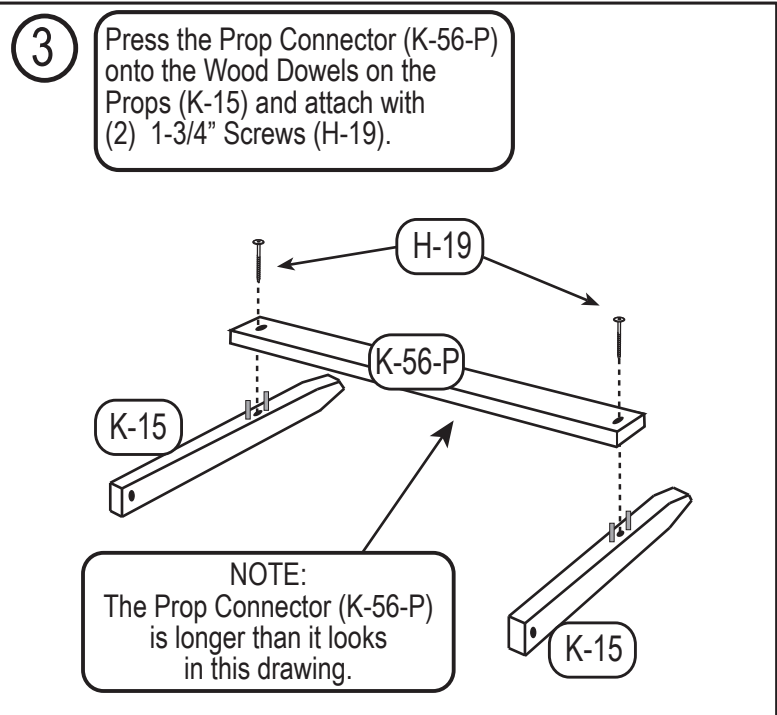
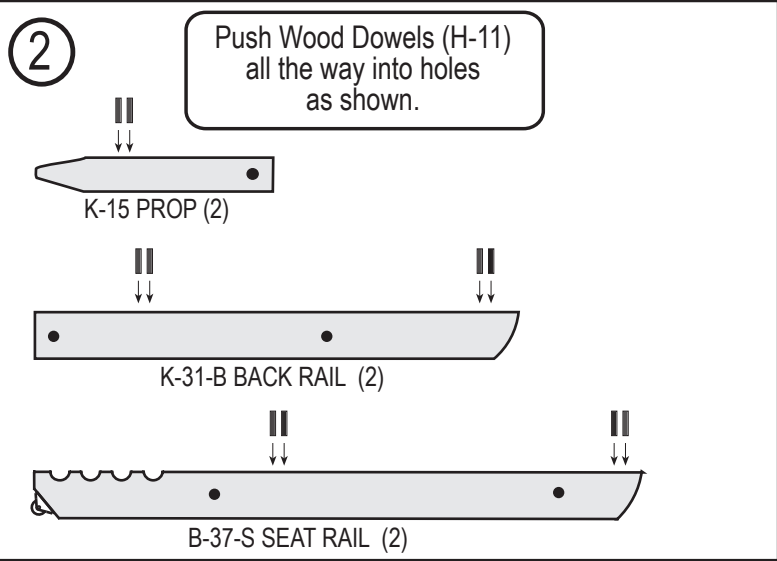
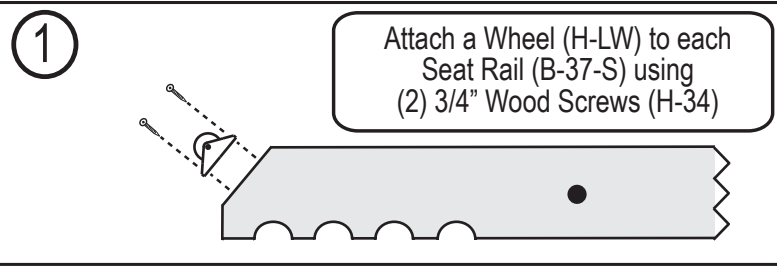
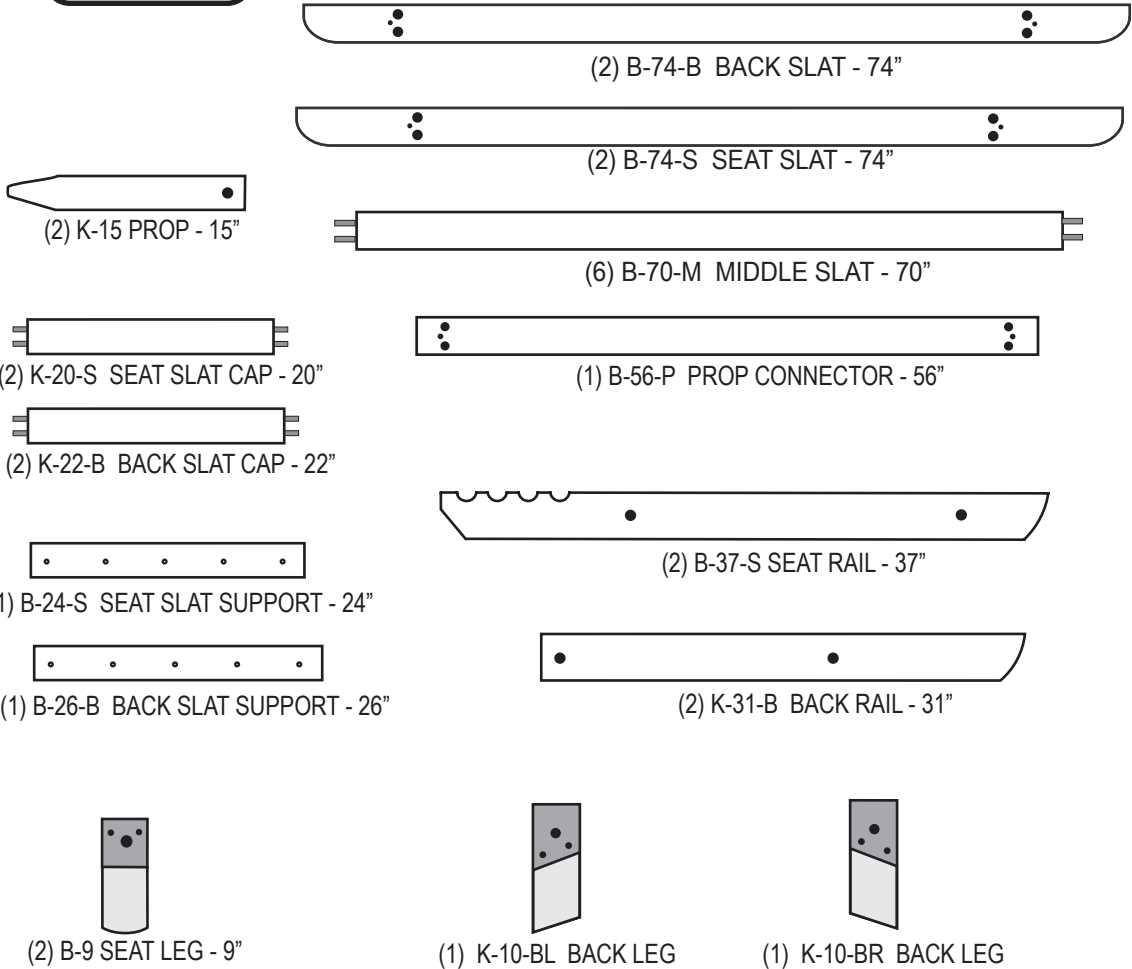

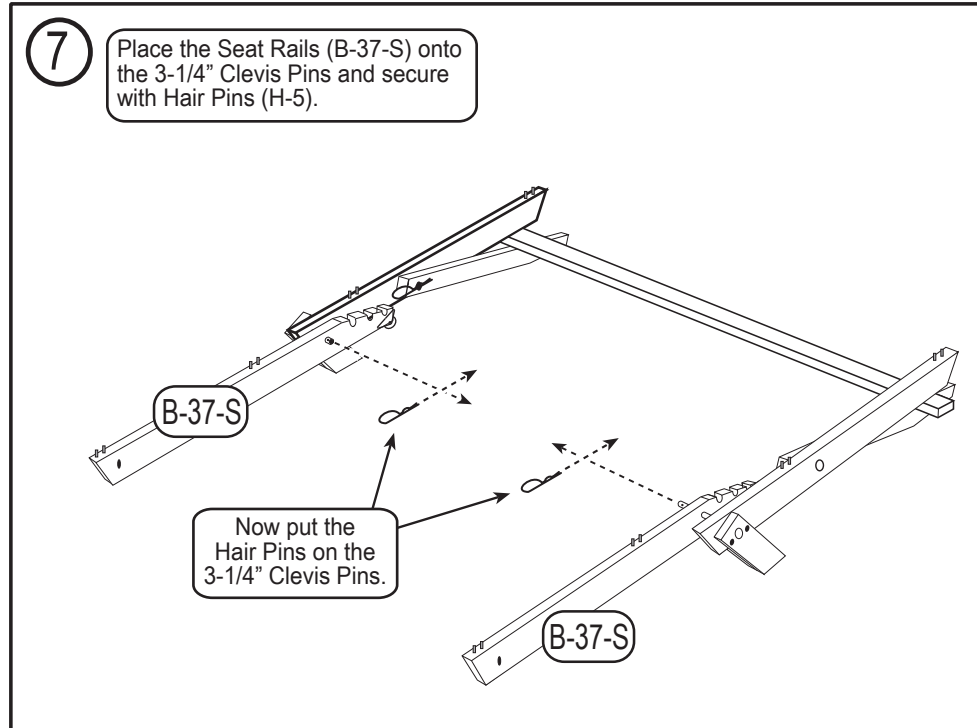
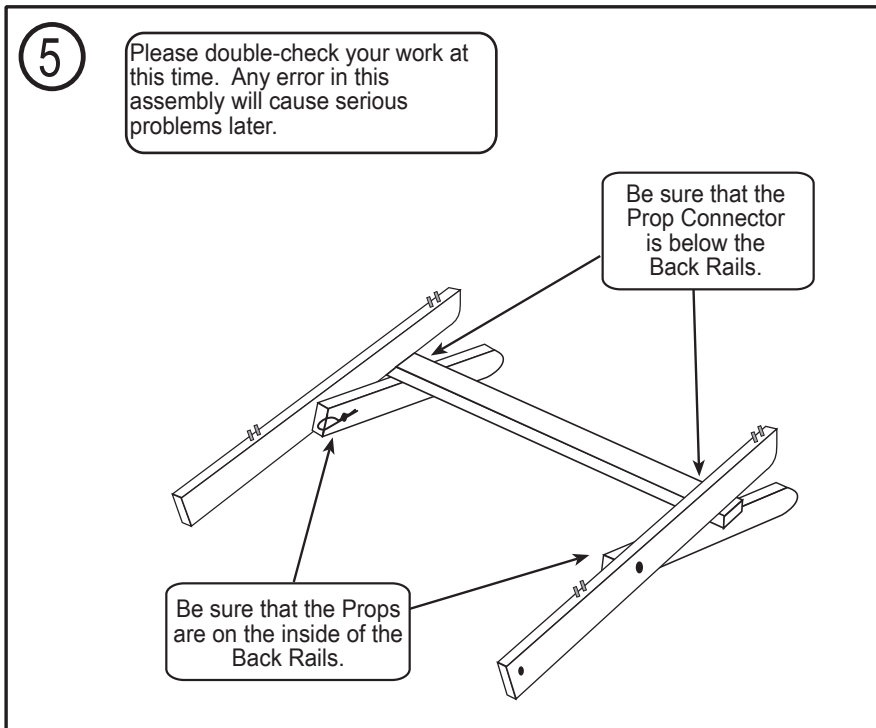
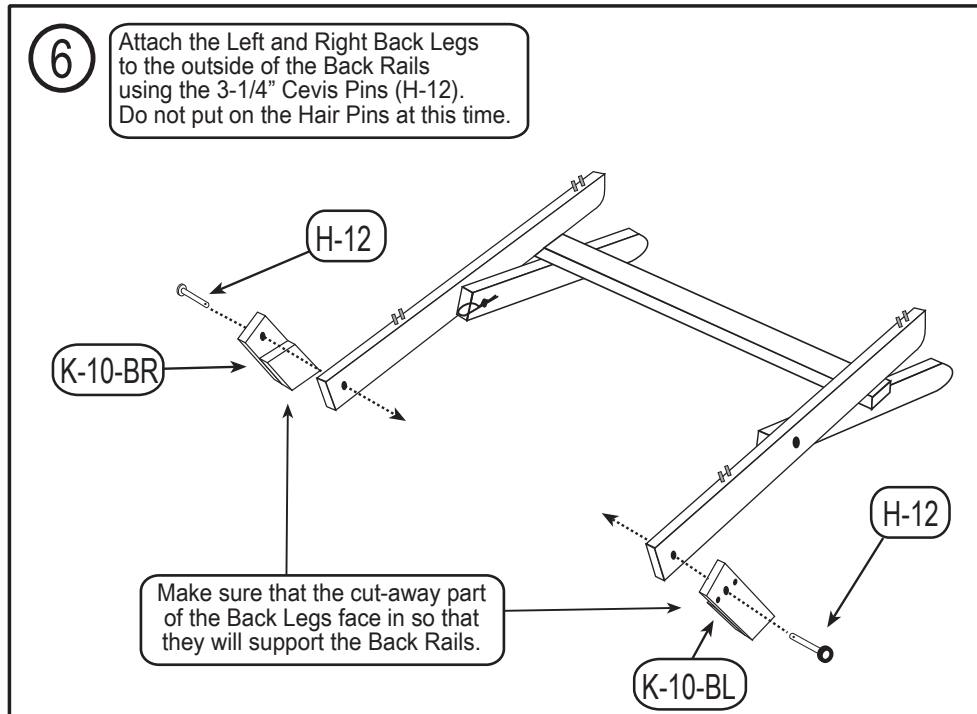
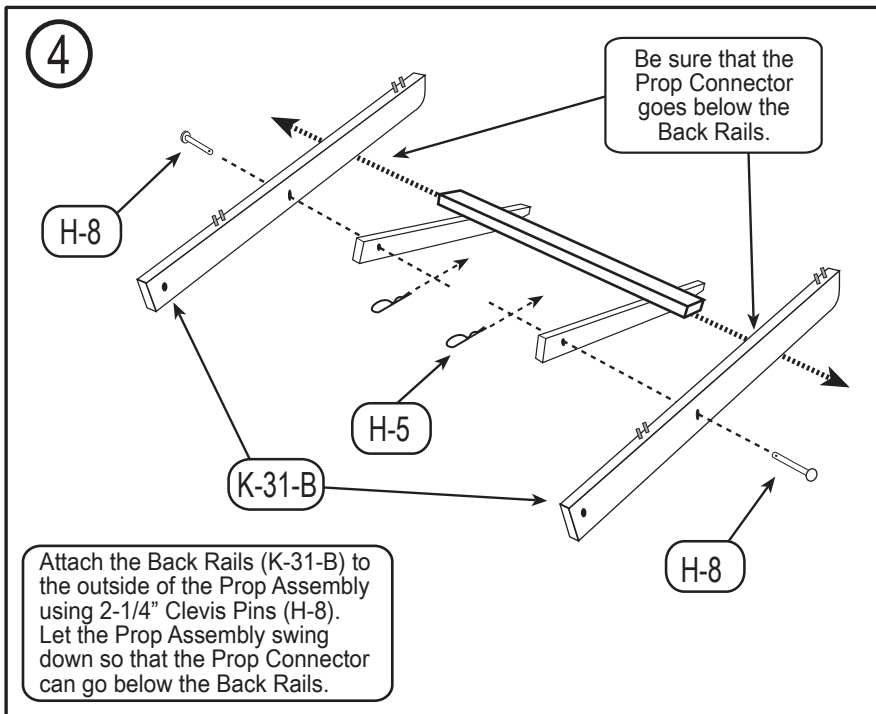

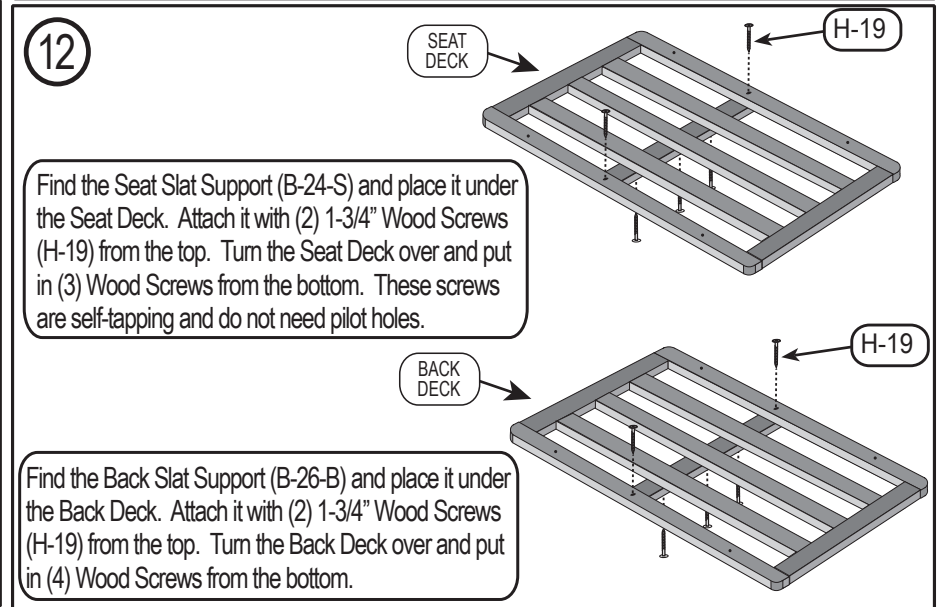
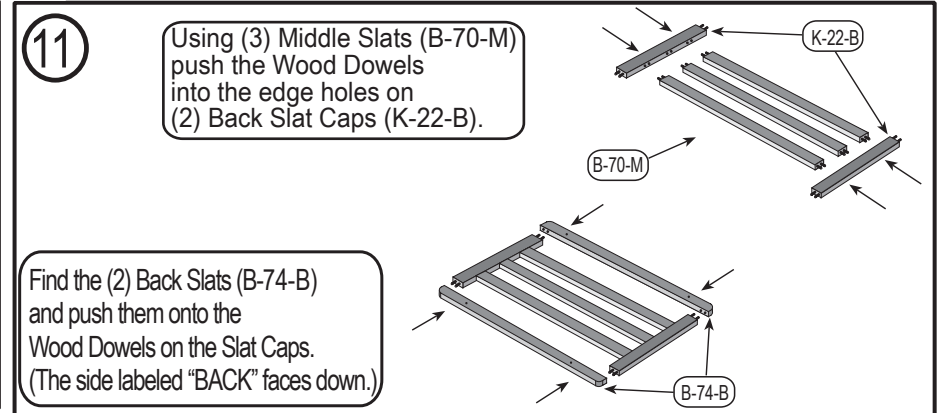
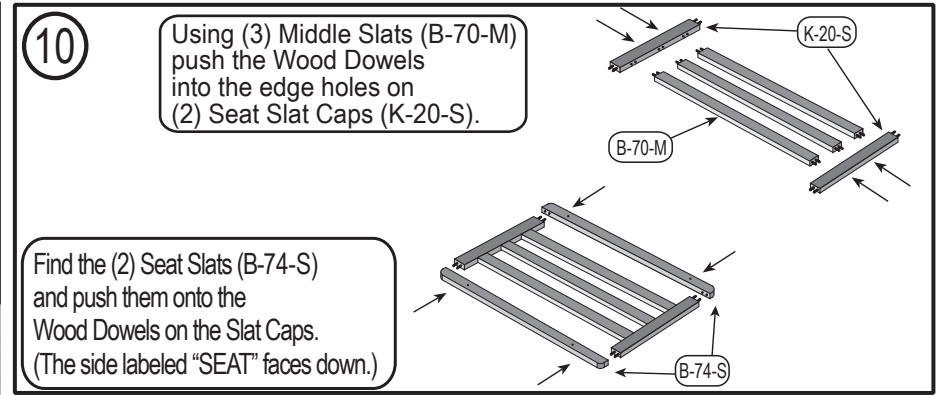
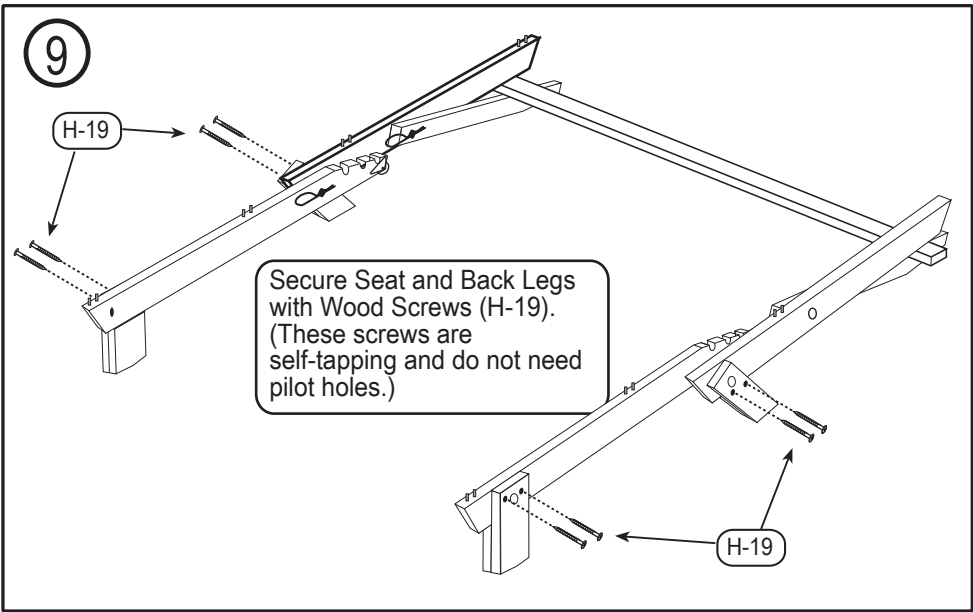
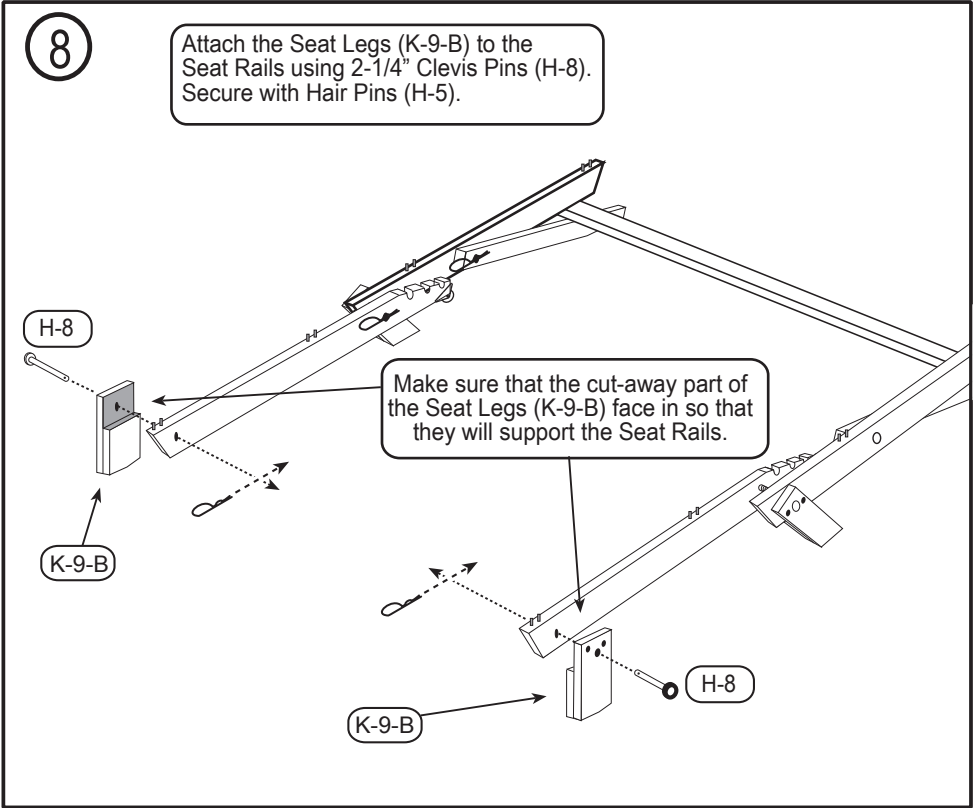

14

Push the Slat Decks down onto the Wood Dowels and attach with Wood Screws. (H-19).

Note: The base may need to be shifted to get the dowels to align with the holes.

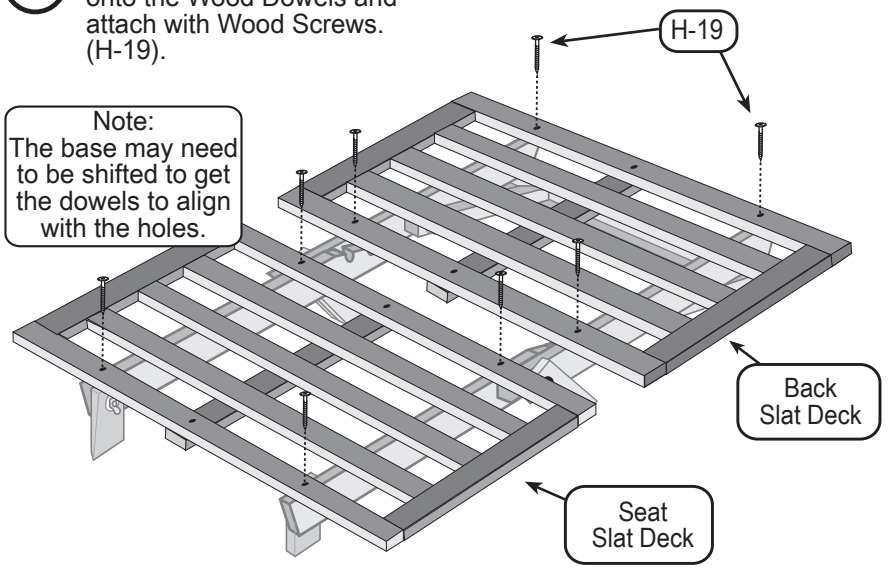

Note: Wood Screws are self-tapping and do not need pilot holes.

This futon frame is made with Tulip Poplar. Any green tint in the wood will change to light brown in a few weeks. This will happen in 20 to 30 minutes if placed in direct sunlight. Tulip Poplar can be left unfinished, clear finished, stained, or painted. I prefer the lighter stains over the darker ones because the wood is fairly porous. My favorite is a clear finish with no stain. Satin polyurethane (oil or water based) works well.

Painting: It is best to start with an interior primer and lightly sand before painting.

Staining: Lightly sand before staining. Wipe stain on with a rag until you get the desired color. If you are going to use a top coat (such as polyurethane), do not sand again until after the first coat, and then be careful not to sand away the stain.

Finishing: All finishes work well with Tulip Poplar. A simple wax finish over stain (Minwax for example) is easy. An oil finish such as Danish oil can be used. Or a clear top coat such as polyurethane works well to seal the wood. With polyurethanes, the first coat acts as a sanding sealer. So you should lightly sand (180 - 220 grit sandpaper) after the first coat, wipe the wood clean, and then build up coats for the desired effect.

# Operation:

Bed position:

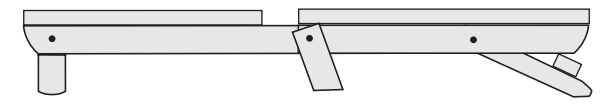

Sofa position:

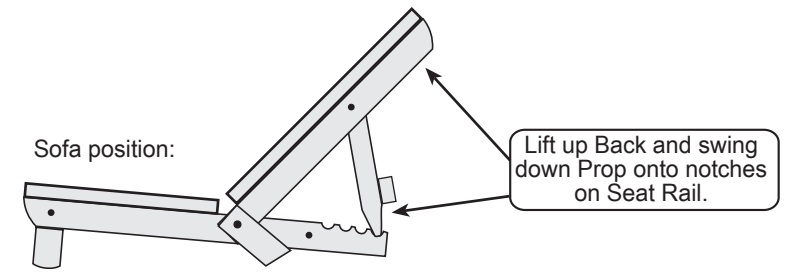

Sofa position:

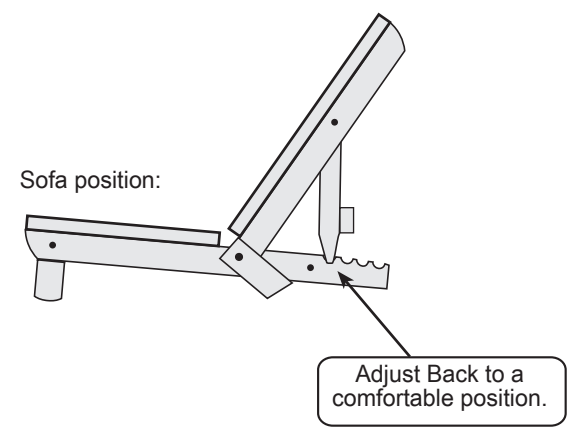

We warrant all of our products for five years against any defects that are due to faulty materials or workmanship. We will promptly correct such defects by repair or replacement, at our option, without charge. This warranty covers product defects only and will expire five years after date of purchase by the original consumer purchaser, with proof of purchase required.

This warranty does not apply to damage caused by and resulting from misuse, neglect, accident, or improper operation, maintenance, storage, transportation, or handling of the product. This warranty is for the original consumer purchaser for residential use only and does not apply if the product is used in any commercial application (such as rental property). This warranty does not cover any incidental or consequential damages. If you feel that you have a claim under this warranty, please contact the store from which it was purchased. If this is not possible, call us for advice on handling your claim.