

Recliner Chair

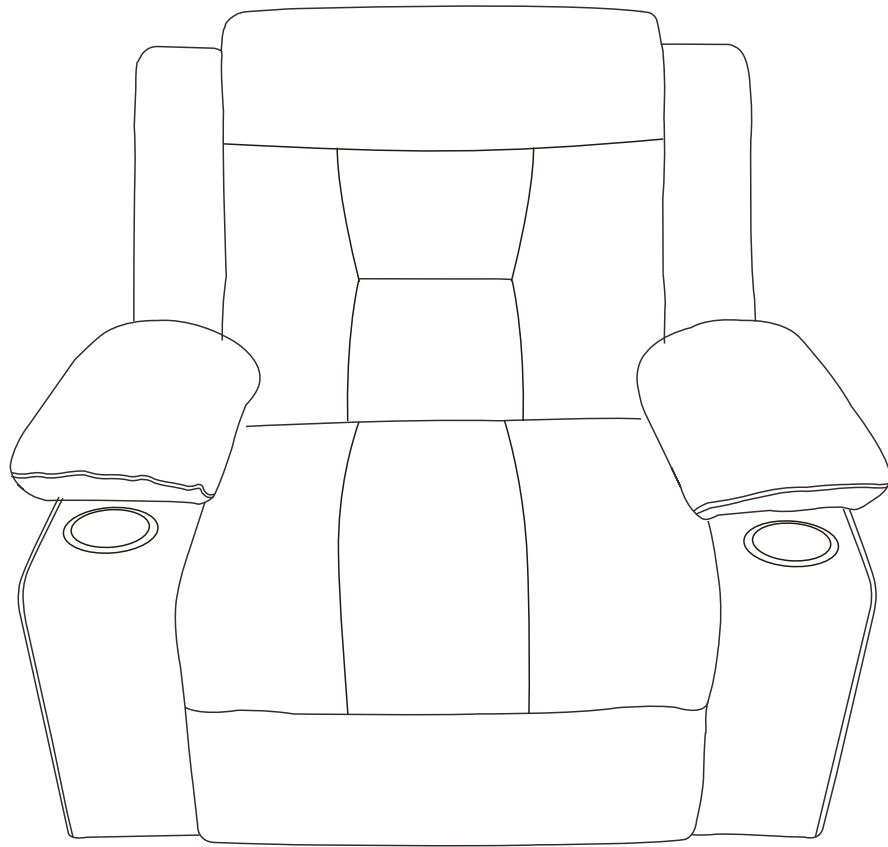

receiving the package. If you have any questions or don't understand something, feel free to contact us. We hope the product brings you joy.

Recliner Assembly Instructions

Estimated Assembly
Time in Minutes

★ ☆ ☆
<15 <45 60+

Your recliner comes packaged in tow box.

DO NOT use any sharp objects to open plastic wrapped components as damage to product or components may result.

Carefully remove all of the components from the packaging and set aside for assembly. Assemble on a soft surface to prevent scratching the finish.

Parts List

BOX1

A 1x Back

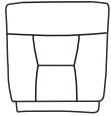

B 2x Armrest

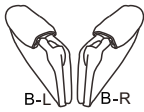

C 2x Arm Pads



BOX2

D 1x Seat

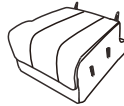

E 2x Back Wings

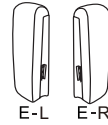

F 2x Cup Holders



G 1x Spring Coil Cushion



H 1x Power Kit



I 1x Remote Control



J 1x Remote Control



Assembly

Step 1

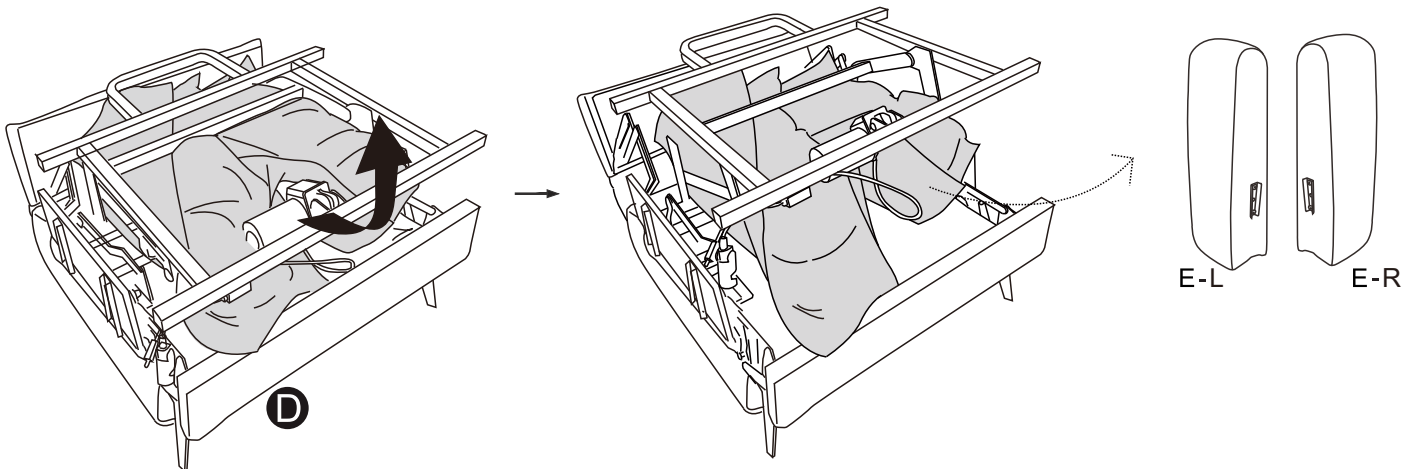

Step 2

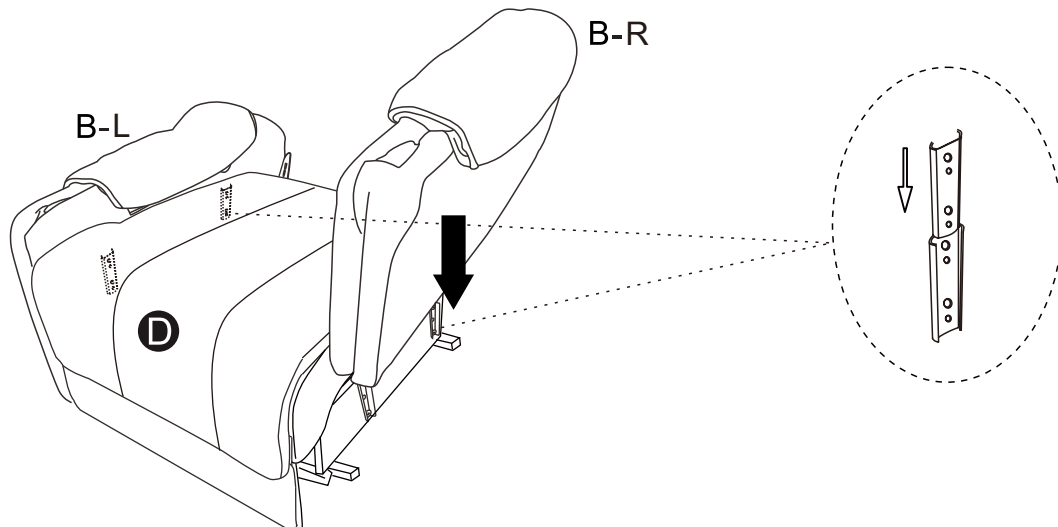

Assembly

Step 3

Pull hard

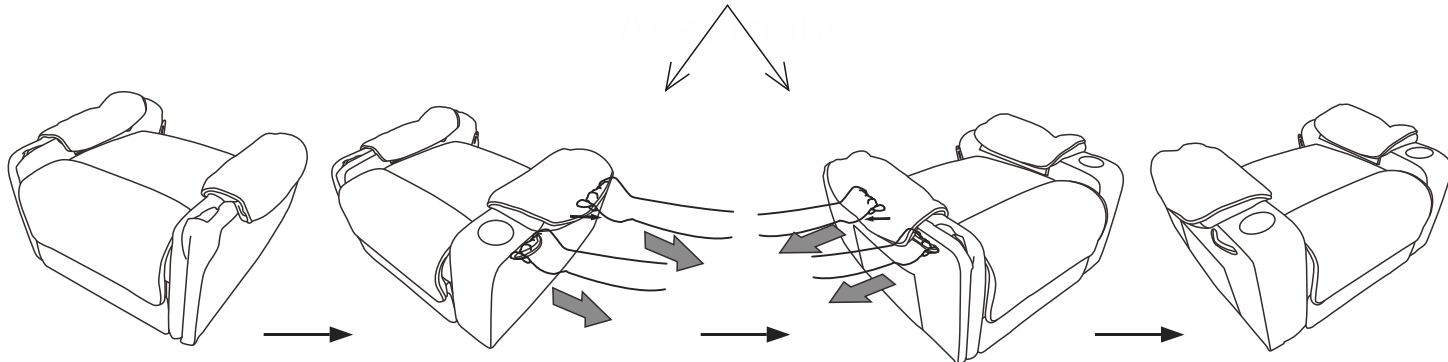

Hold the handle of the arm and pull hard to make it stretch out.

Step 4

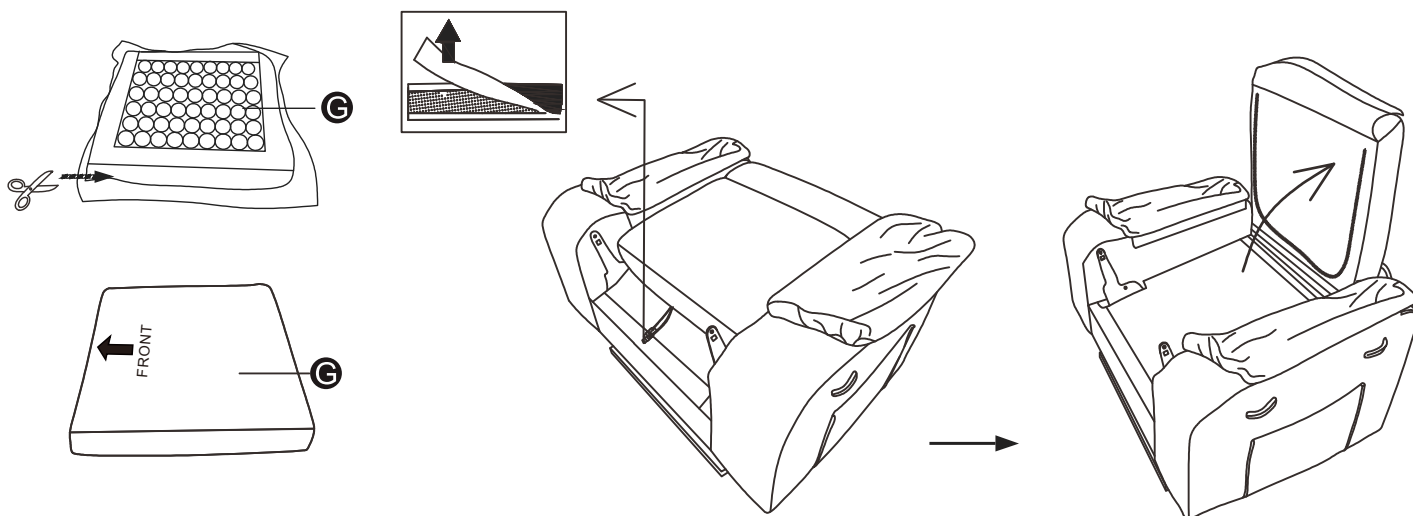

Step 5

Open the zipper

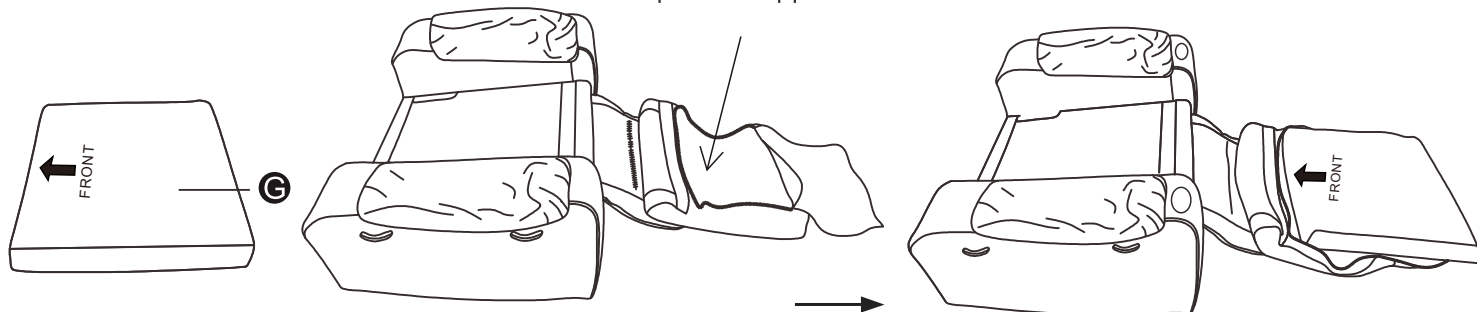

Put spring coil pad inside of the seat cushion cover and zipped.

Assembly

Step 6

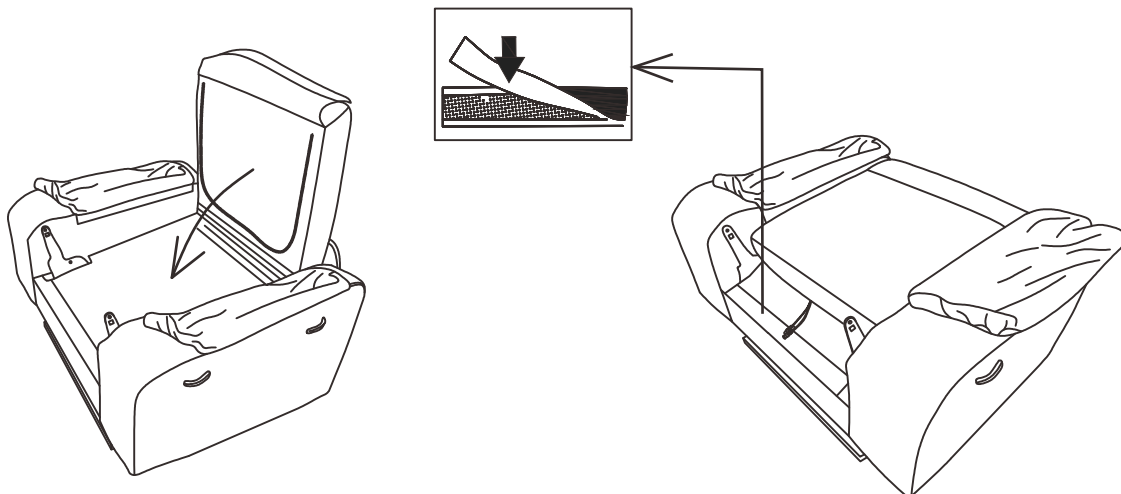

Then put the whole seat cushion on the center of seat base correctly and tighten the velcro.

Step 7

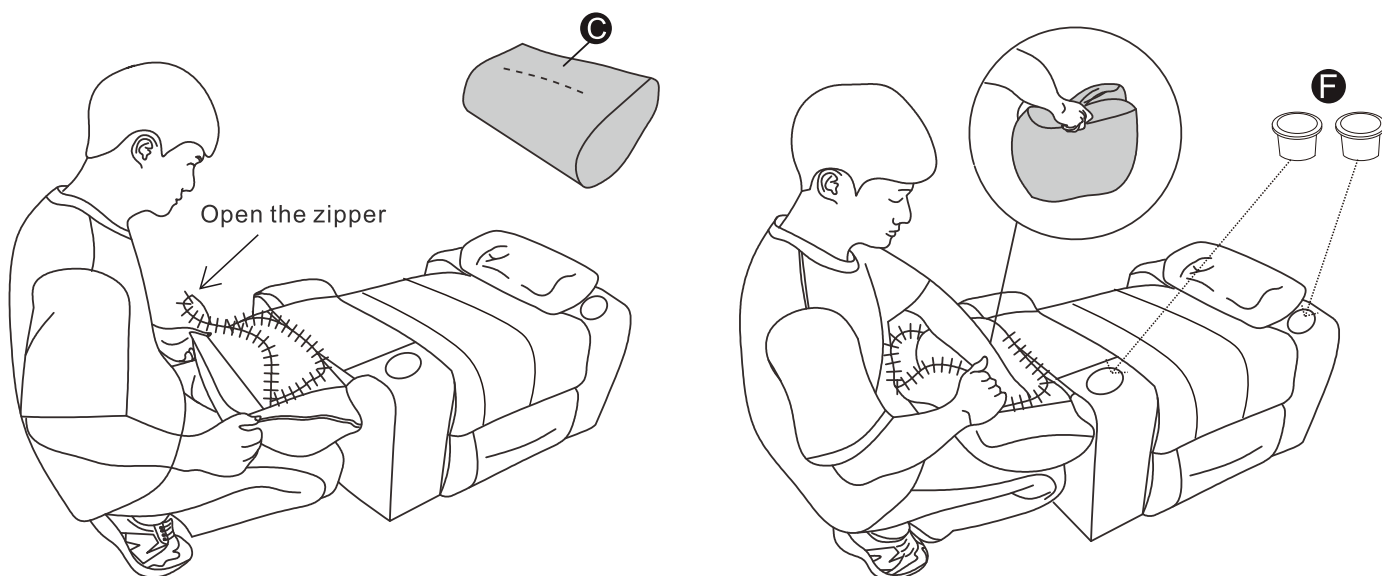

Step 8

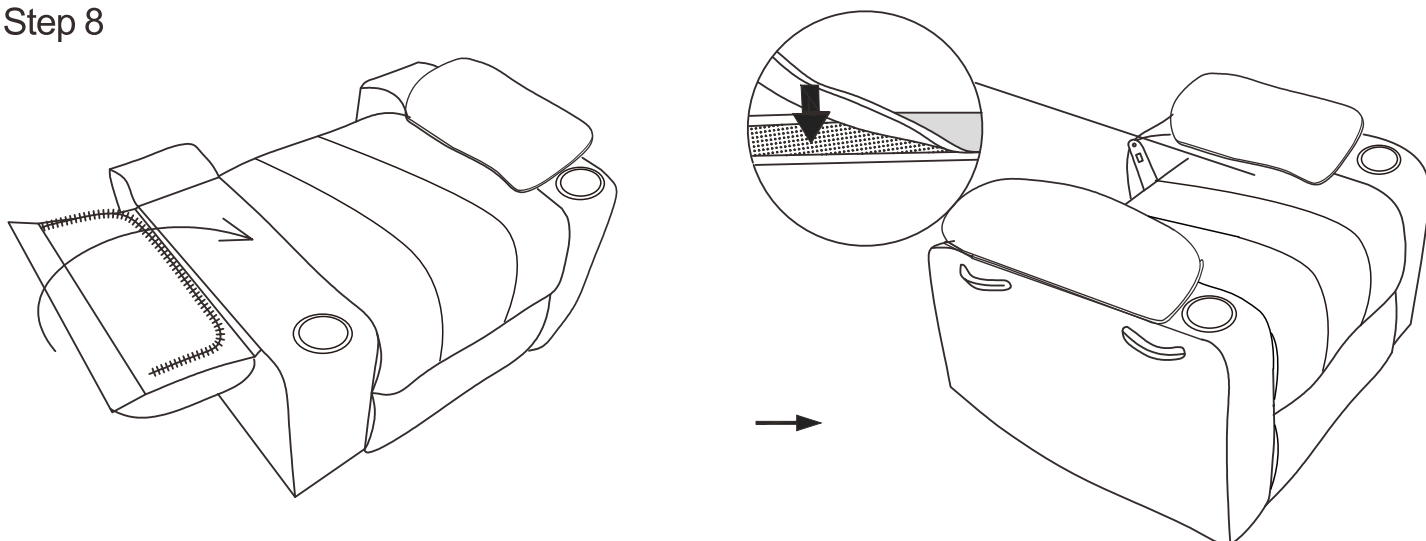

Assembly

Step 9

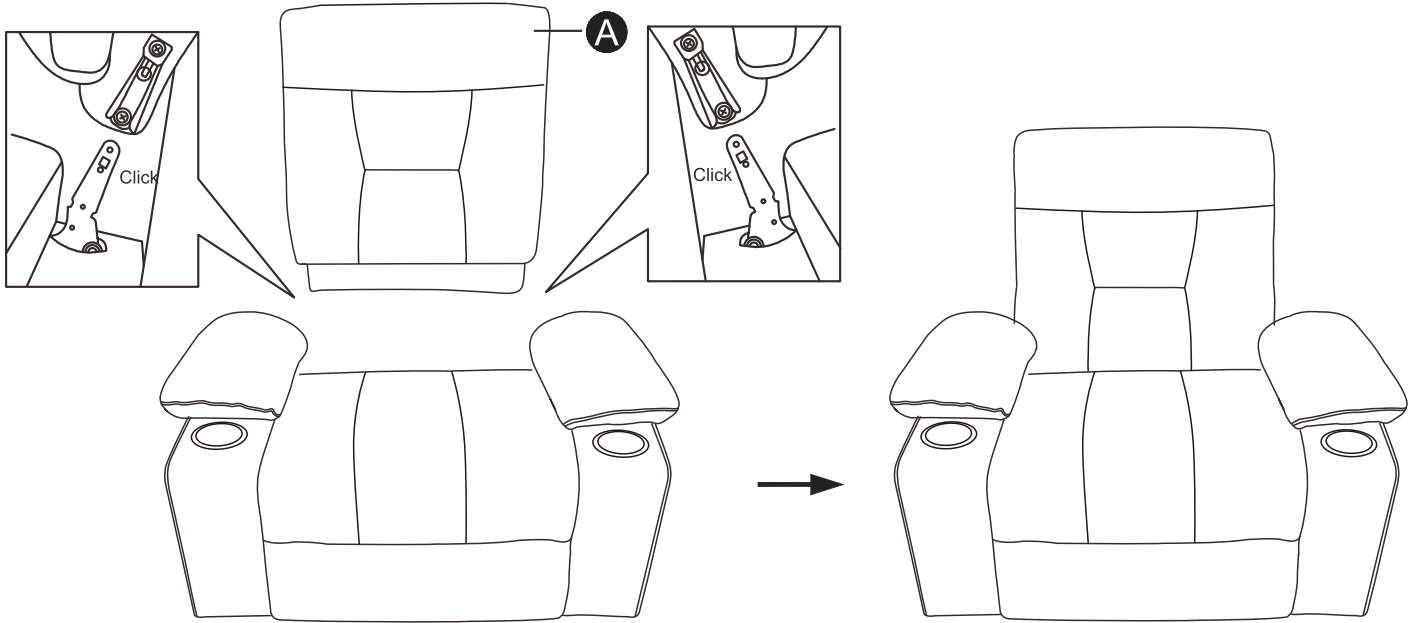

Step 10

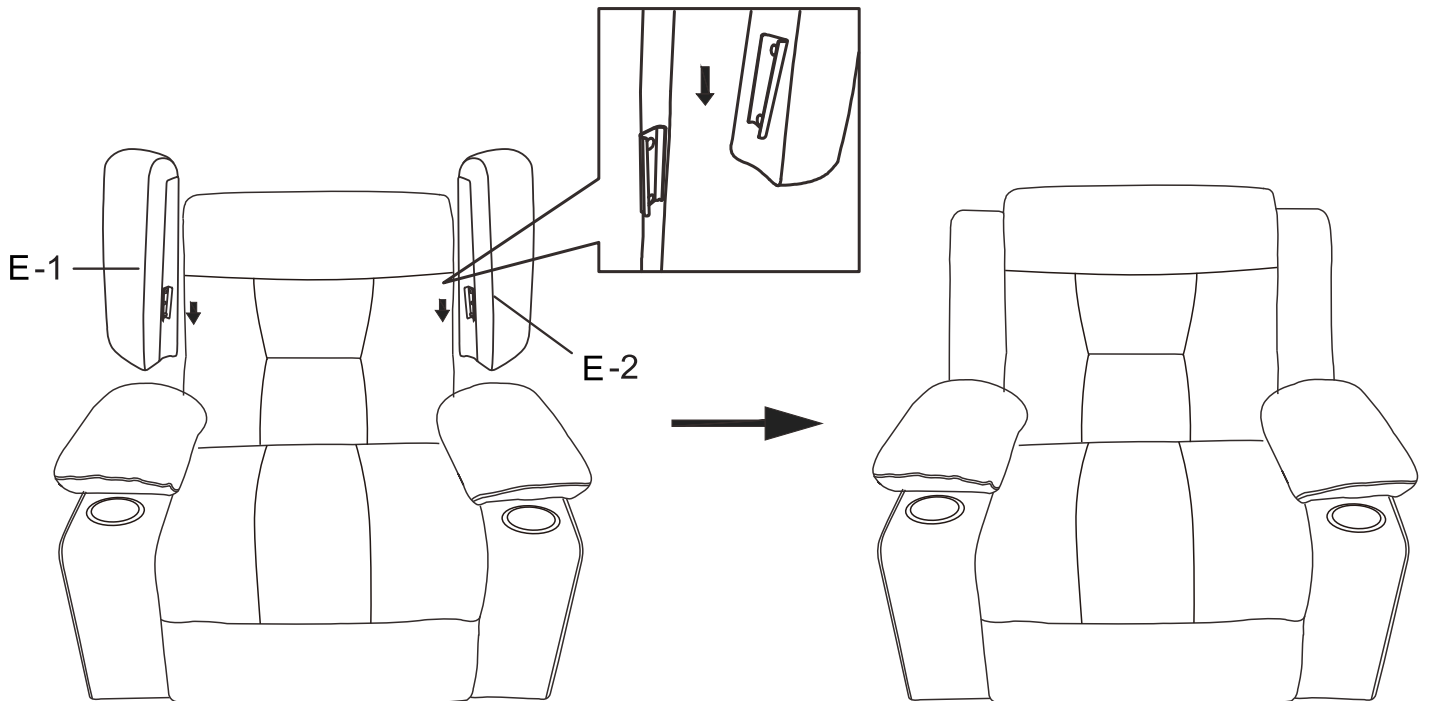

Assembly

Step 11

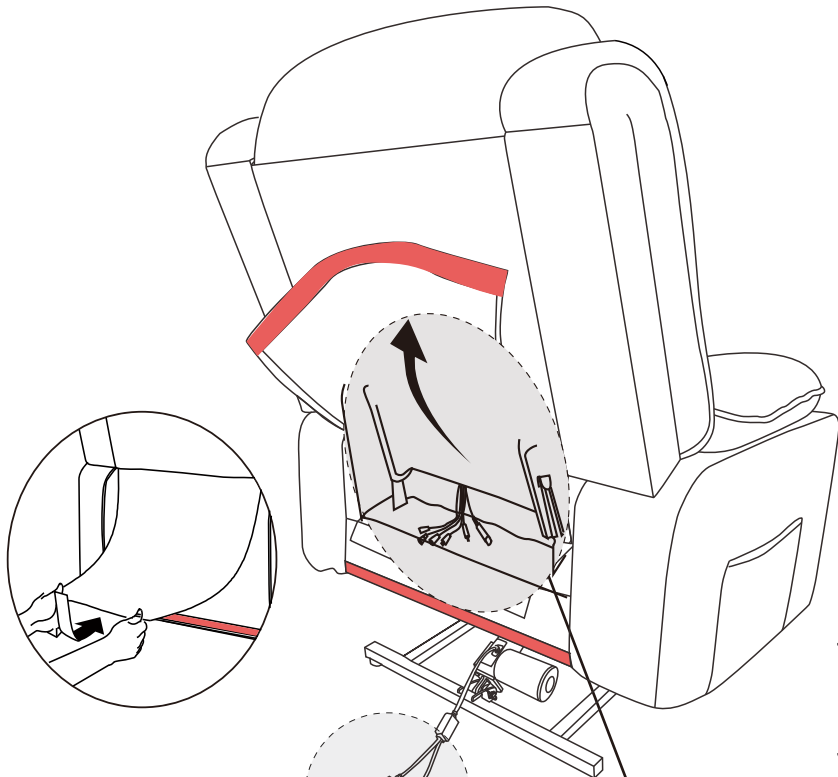

Unstick the Velcro of the seat base and the backrest. Then connect the cables.

Connect ① ② with wires of same color from the seat base.

Connect ③ with Power cord ⑥ and ④ with Remote control ①.

Connect ⑤ with Power cord ⑥ and ⑥ with Remote control ②.

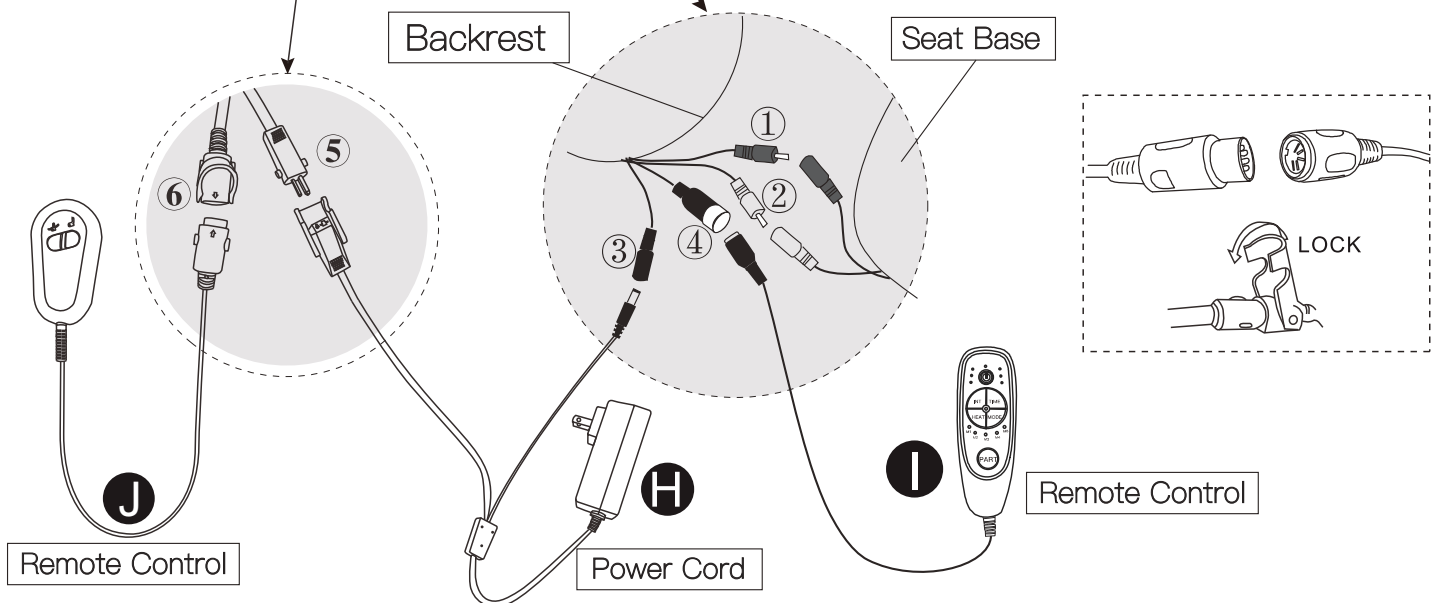

Assembly

Step 12

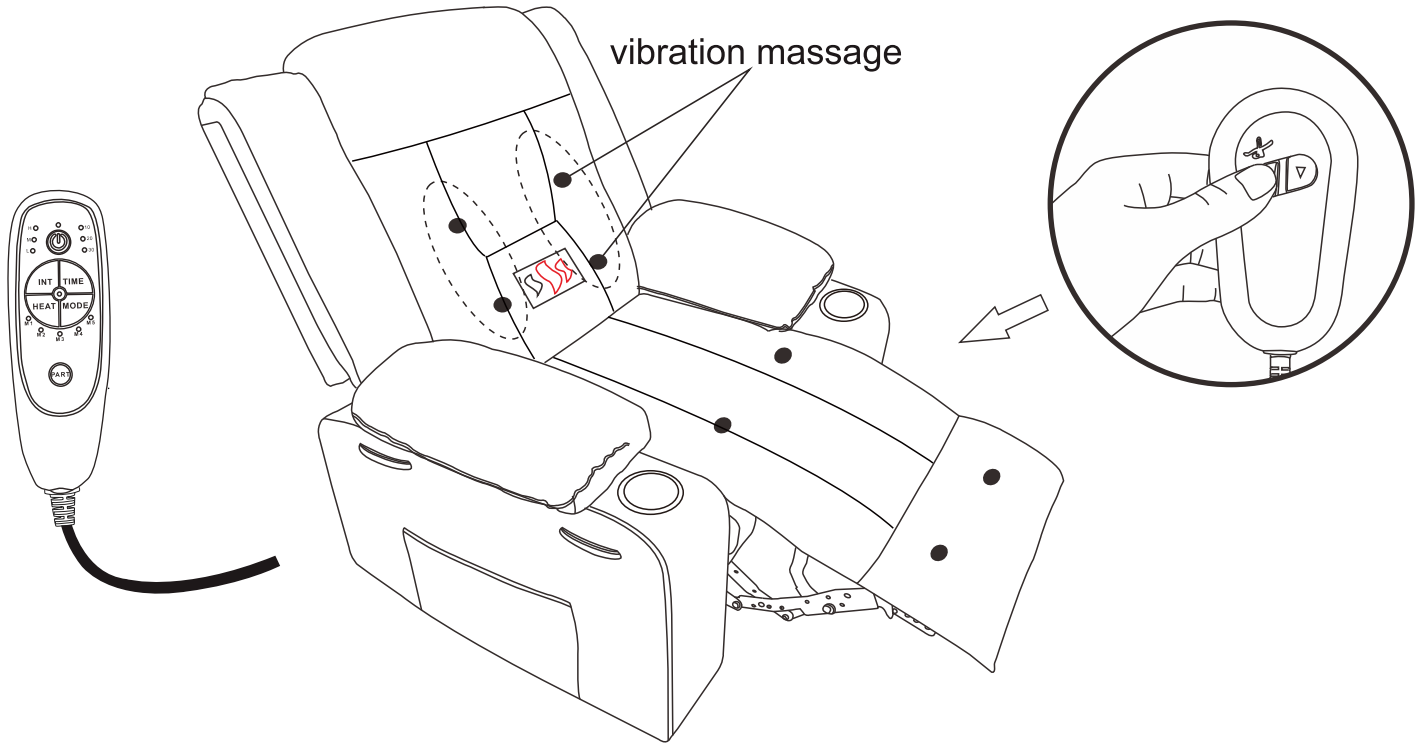

When sitting on the chair, press the left side button of the remote control to tilt the chair completely to backward and extend the footrest. Press the button on the right side to return back .

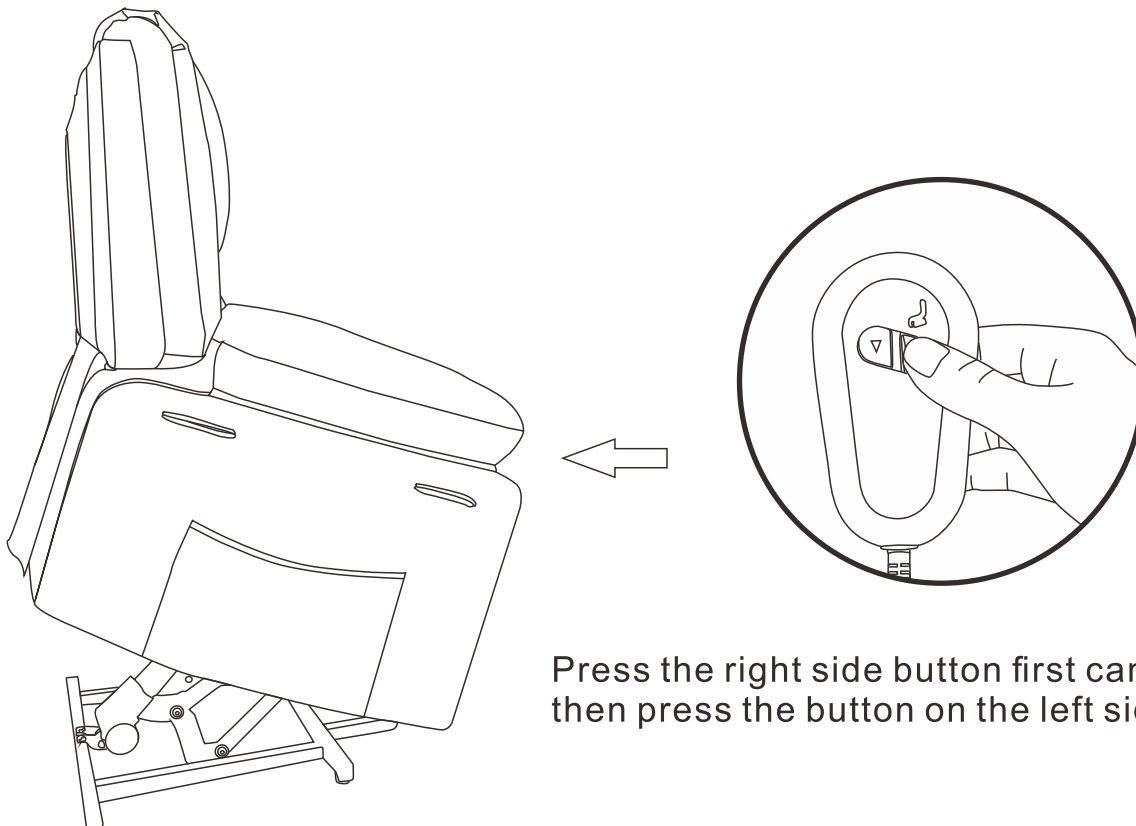

Press the right side button first can let sofa lift up, then press the button on the left side to return .

Assembly

Manual controller function manual

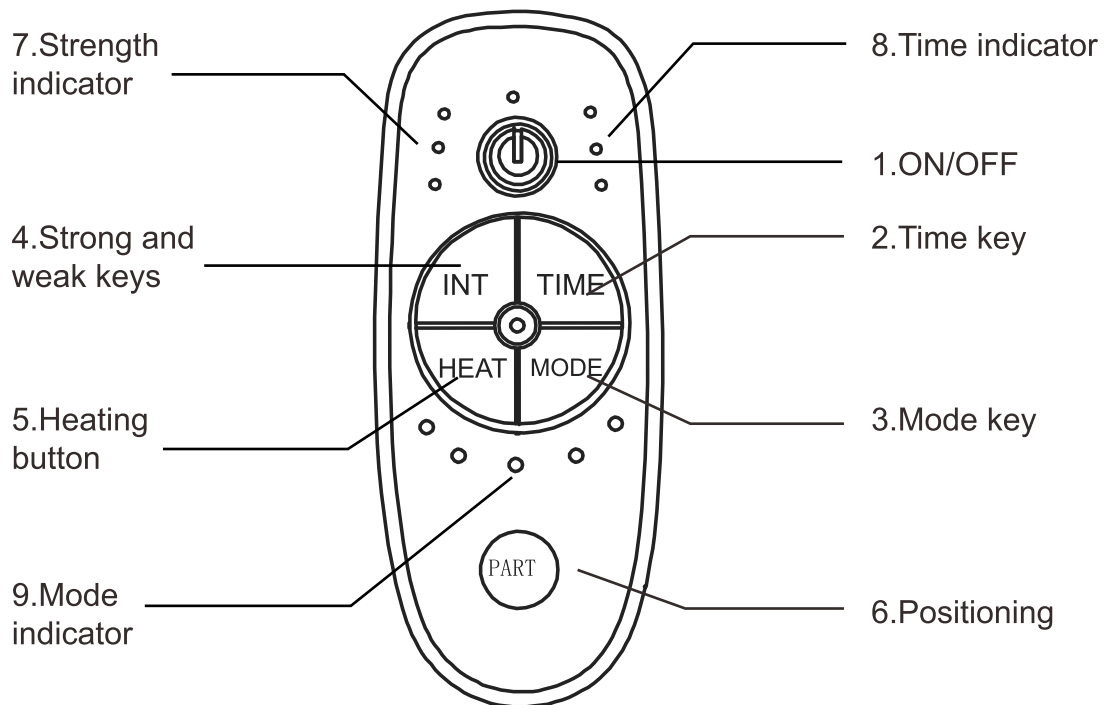

I 、 Specifications of power adapter

Power on in standby state. The user can realize the function through the hand controller control

Input :AC 100-240V, 50Hz/60HZ; Output: DC12V1A.

II 、 Product features

1. Motor vibration at position 8
2. 1-way heating plate
3. Three-segment timing, the default timing shutdown time is 10Min
4. 3rd gear vibration intensity
5. 5 vibration modes

III 、 Function details

1. ON/OFF: Switch on and of
2. TIME: Positioning cycle by massage time (10/20/30 min) , Boot default 10min
3. MODE: Tap the five vibration modes to switch (M1/M2/M3/M4/M5) ,The default startup mode is M4
4. INT: Switch point by vibration intensity (H/M/L) ,Boot the default M file (medium Files)
5. HEAT: Click heating switch circulation
6. PART: Vibration positioning key , Boot the default vibration is full on, tap to switch to a single part vibration
7. Strength indicator
8. Time indicator
9. Mode indicator

Proper Usage

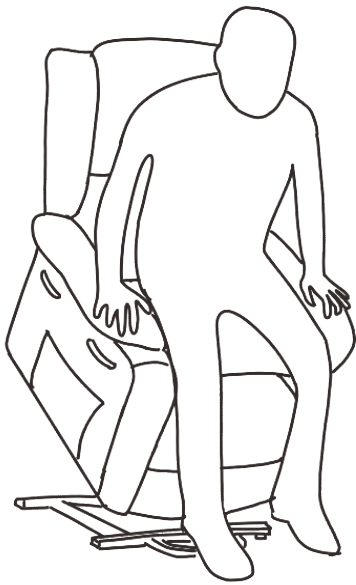

- Steps to safely stand up from your Lift Recliner
1. Store remote safely in the recliner's side pocket
 2. Plant feet firmly on the ground
 3. Evenly distribute weight on both arms of the chair
 4. Slowly stand up from lift position

*Remember to store remote safely in the recliner's side pocket when it is not in use

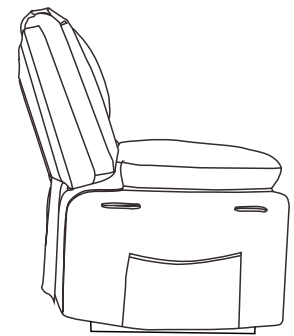

*Fabric will fade or discolor in direct sunlight. Minimize exposure to direct sunlight to extend the life of your furniture.

Improper Usage



DO NOT stand up when the footrest is in the upright position

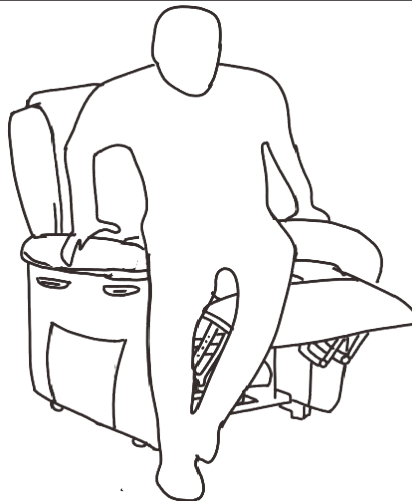

DO NOT stand up from your recliner with uneven weight



DO NOT stand up from your Lift Recliner with one arm

Your recliner style may differ from images. Care for your furniture by periodically tightening all bolts.

About your furniture piece:

- Softening of foam is natural and will happen over time with use.
- Fabric will fade or discolor in direct sunlight. Minimize exposure to direct sunlight to extend the life of your furniture.
- Wood grain, knots, streaks, and color variation occur naturally in wood and are not considered defects.

CAUTION:

CAUTION: Tighten all components securely before use. Failure to do so may result in personal injury.