

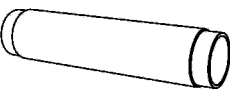



# Sku:6090-Snail-S2L

## ASSEMBLY INSTRUCTION

### BILL OF MATERIAL (NUMBER AND QUANTITY)

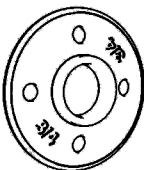
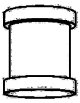
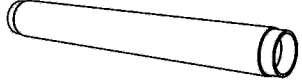
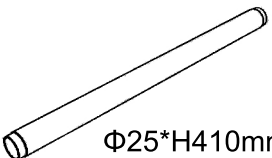
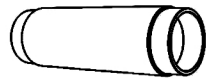
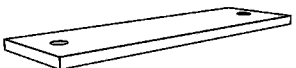
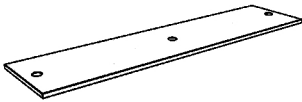
A	5	 Φ25*H35mm	B	6	 Φ25*H100mm
C	6		D	6	
E	10		F	2	 Φ25*H250mm
G	1	 Φ25*H410mm	H	5	 Φ25*H90mm
I	1	 L650*W250mm	J	1	 L1200*W250mm
K	5		L	24	
M	24				

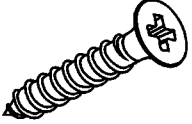
# Exploded View

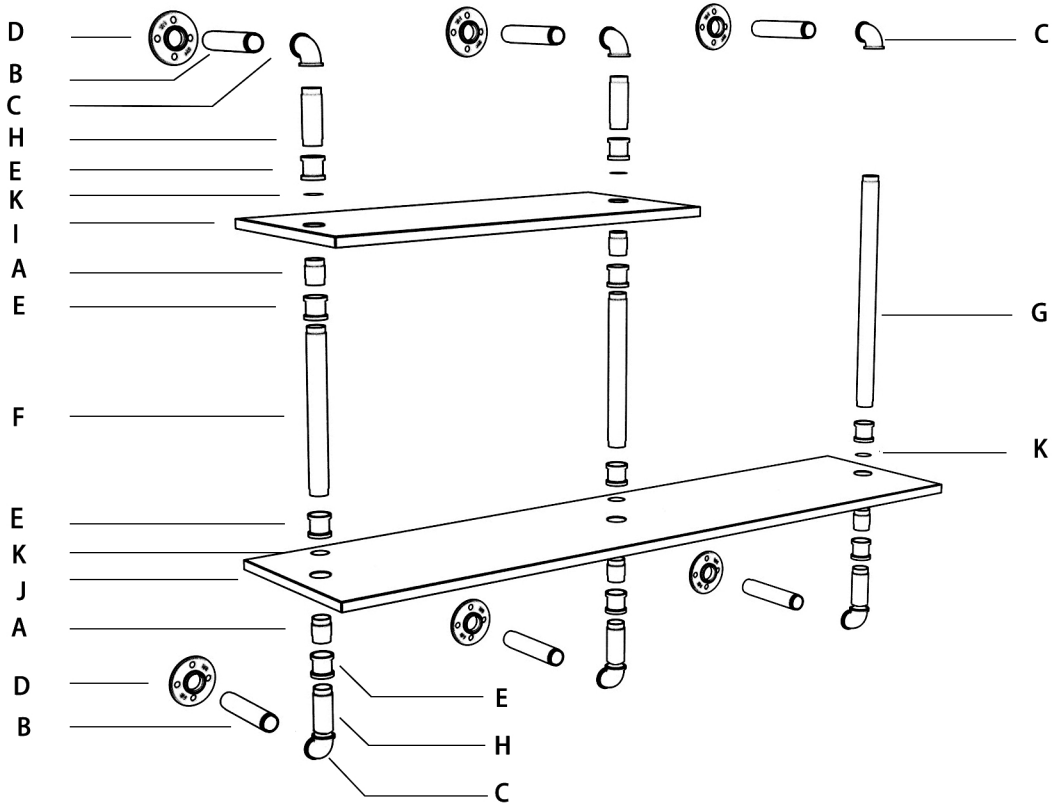

# Installation procedures

step 1

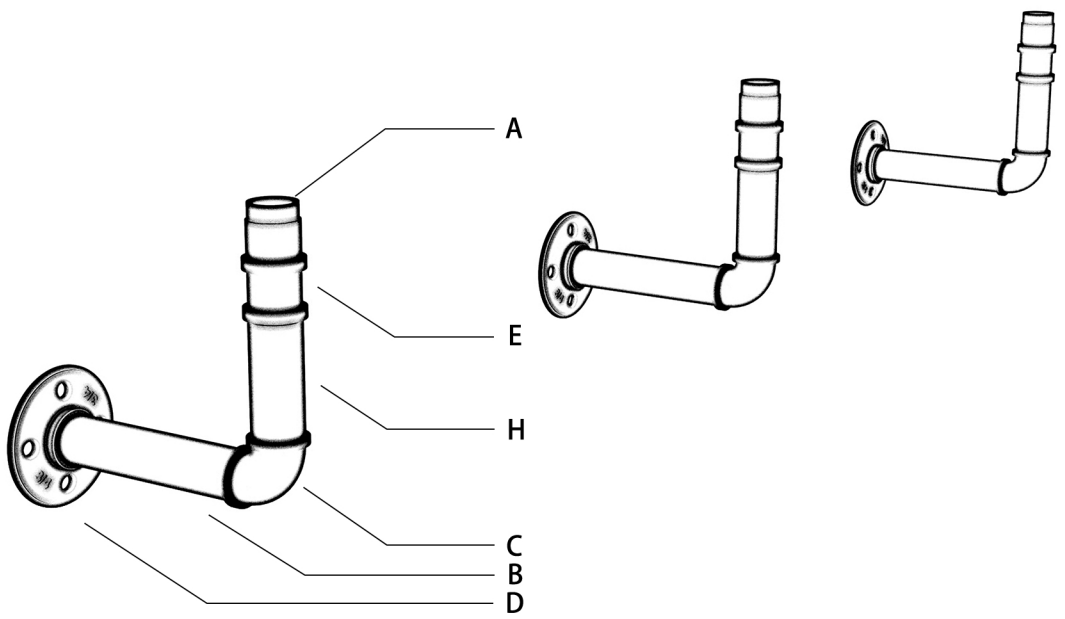

step 2

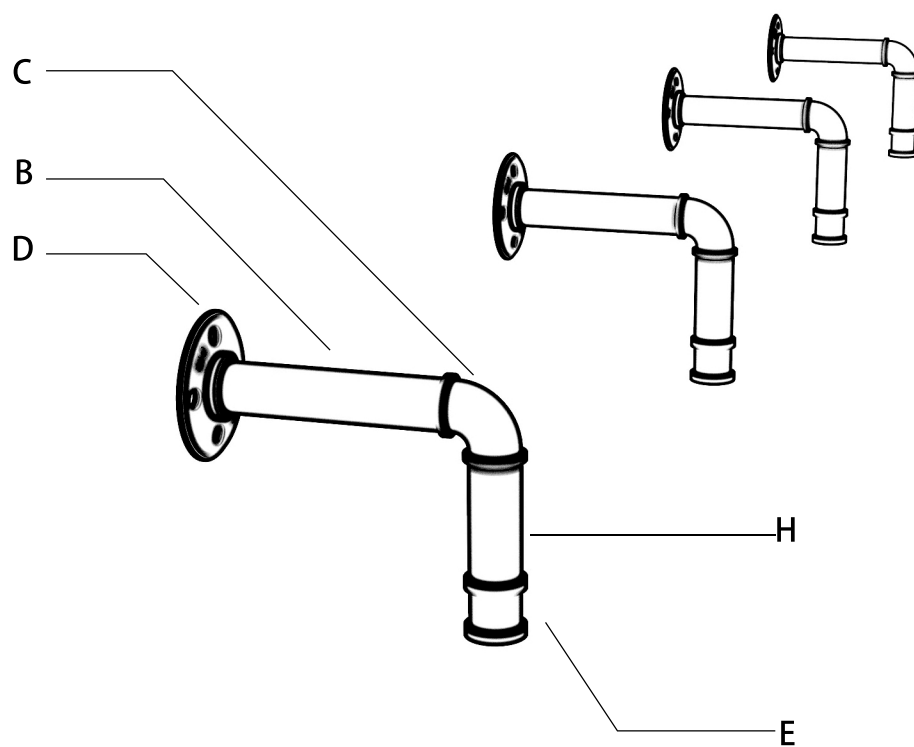

step 3

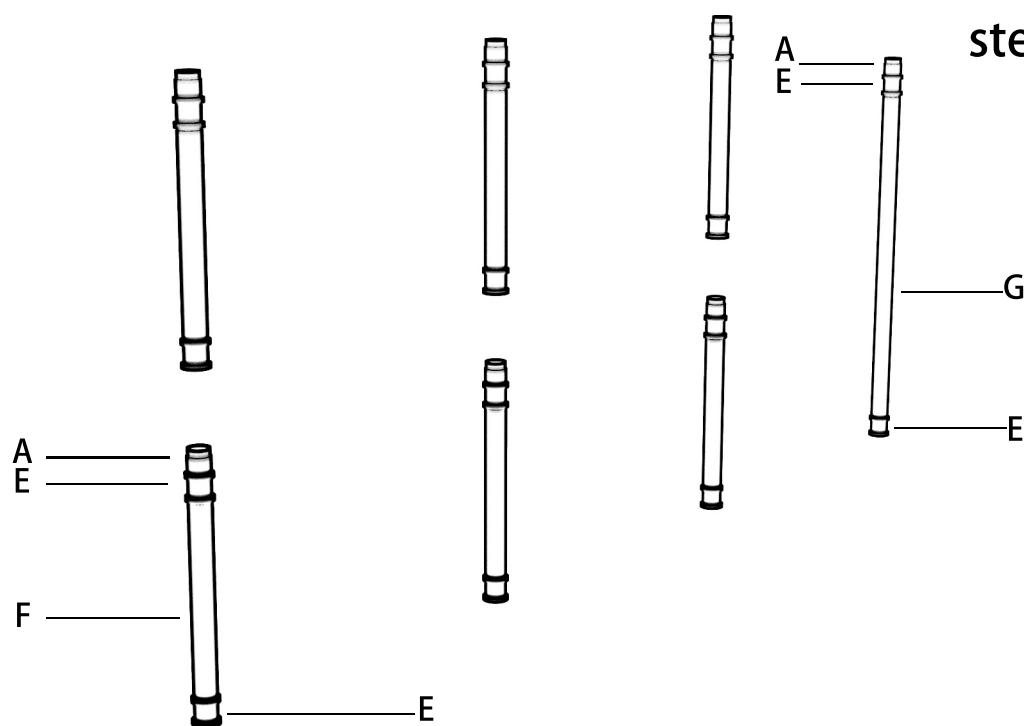

## step 4

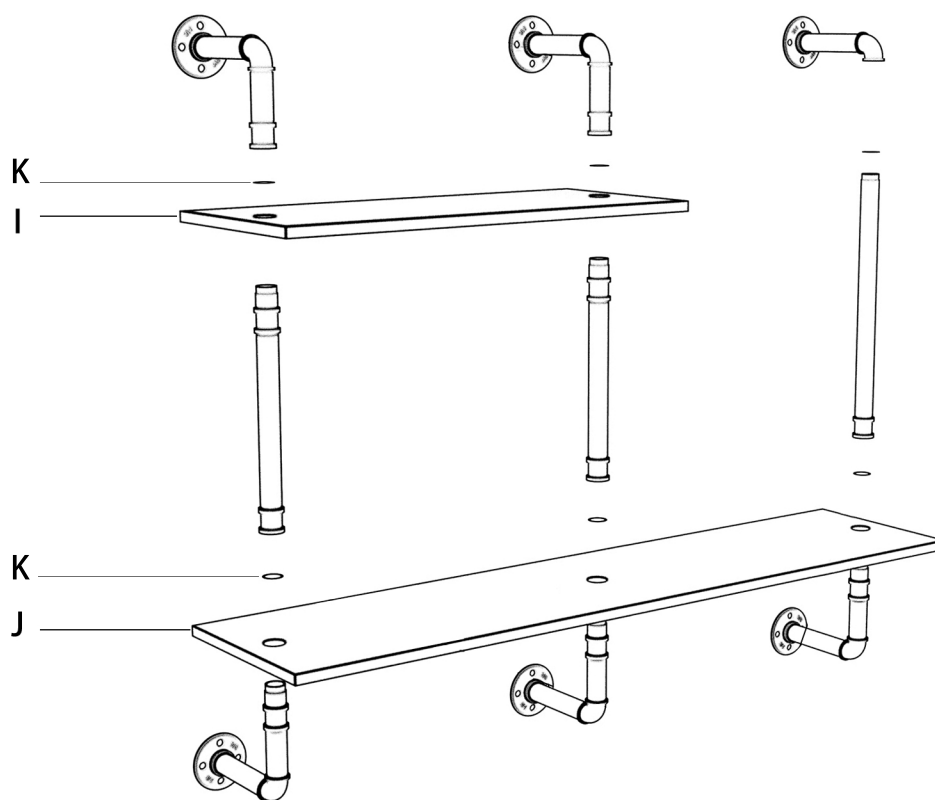

## step 5

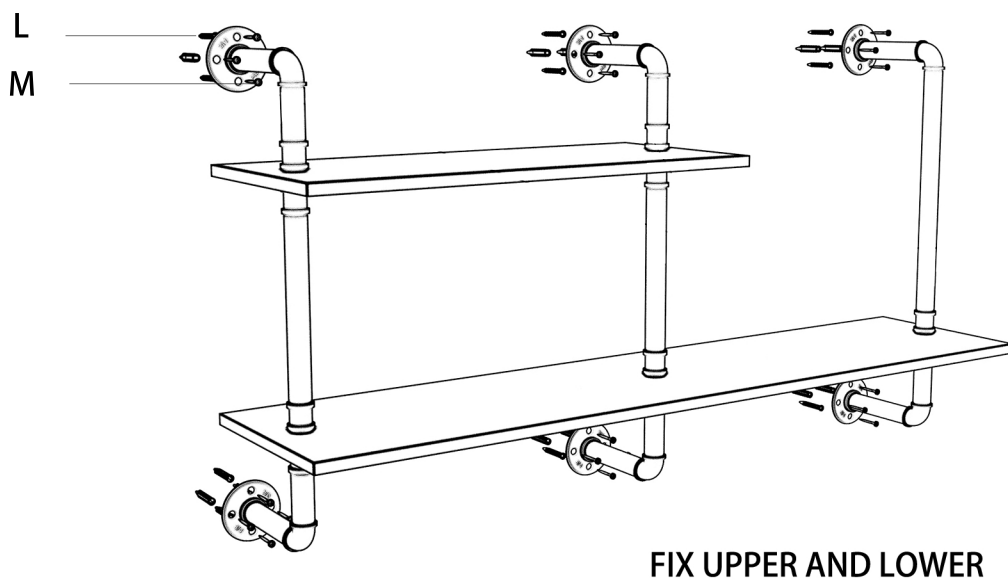

# COMPLETED DRAWING

