

# Montageanleitung | Instructions de montage Assembly Instructions | Instrucciones de montaje

SKU:N601P369579/N601P369580/N601P369581

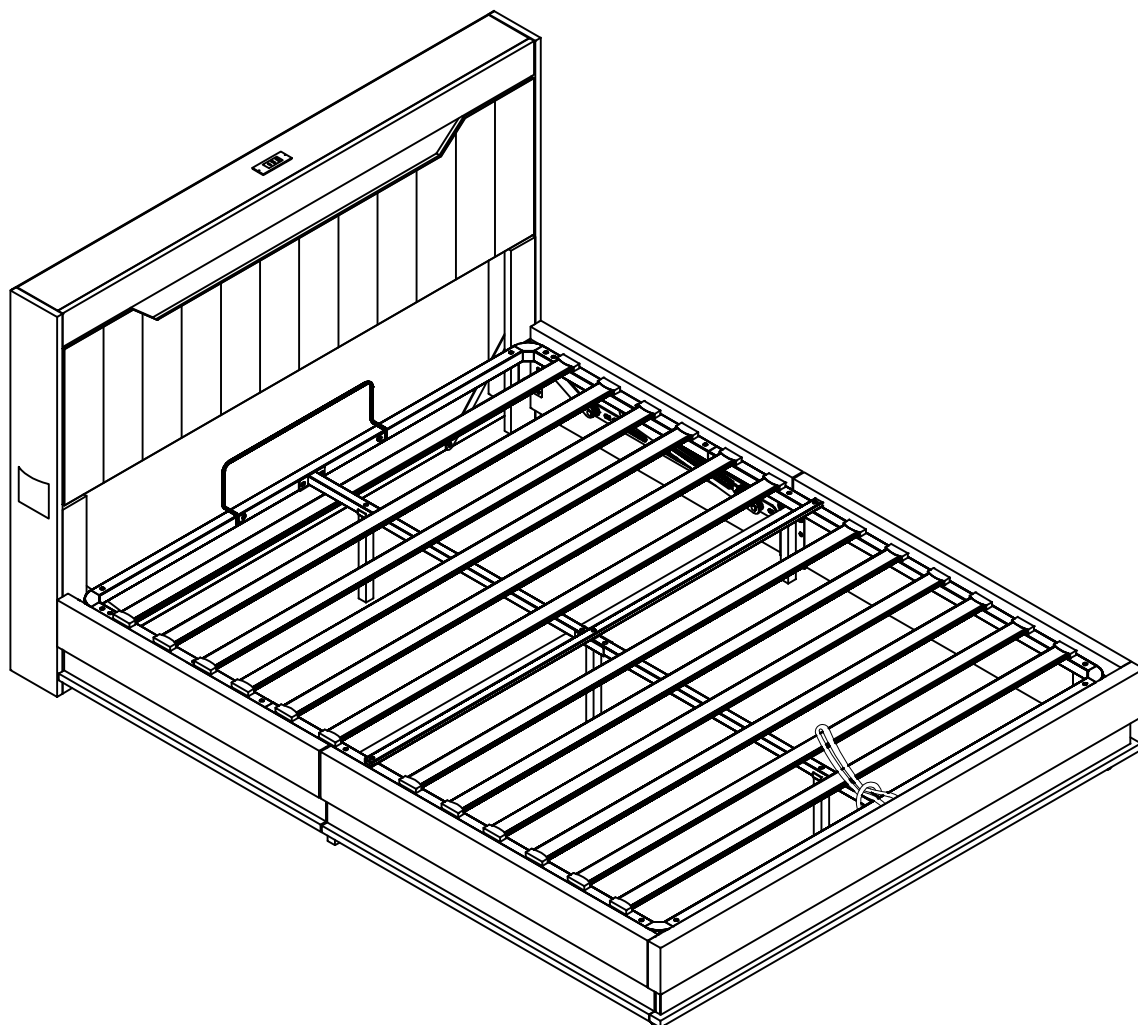

- GB** This set comes in 3 boxes. If you do not receive a full set of 3 boxes, please contact our customer service.
- DE** Dieses Set wird in 3 Schachteln geliefert. Wenn Sie nicht ein komplettes Set von 3 Boxen erhalten, kontaktieren Sie bitte unseren Kundenservice.
- FR** Ce set est livré en 3 boîtes. Si vous ne recevez pas un jeu complet de 3 boîtes, veuillez contacter notre service clientèle.

## English

### IMPORTANT FOR GAS LIFT BEDS&MAINTAINANCE

- Please place the mattress on top of the bed frame.
- Please do not pull on the strap handles.
- Please press heavily to release the compressed gas.
- Periodically check all screw & fixings to ensure they are secure.
- When moving your product, carefully lift into place.
- Wipe clean with a slightly damp cloth- please do not use abrasive chemicals or bleach.
- Do NOT allow children to operate the lift mechanism.
- Do NOT allow children near the lift base when operating the mechanism.
- Do NOT stand inside the bed or the internal storage base.
- Do NOT overload the internal storage base.
- DO NOT jump on the product or any of its parts.

## Deutsch

### WICHTIG FÜR GASLIFT-BETTEN&WARTUNG

- Bitte legen Sie die Matratze oben auf den Bettrahmen.
- Bitte ziehen Sie nicht an den Gurtgriffen.
- Bitte drücken Sie kräftig, um das komprimierte Gas freizusetzen.
- Überprüfen Sie regelmäßig alle Schrauben und Befestigungen, um sicherzustellen, dass sie sicher sind.
- Wenn Sie Ihr Produkt bewegen, heben Sie es vorsichtig an seinen Platz.
- Mit einem leicht feuchten Tuch abwischen - bitte keine scheuernden Chemikalien oder Bleichmittel verwenden.
- Erlauben Sie Kindern NICHT, den Hebemechanismus zu bedienen.
- Lassen Sie Kinder NICHT in die Nähe des Liftsockels, wenn Sie den Mechanismus bedienen.
- Stellen Sie sich NICHT in das Bett oder in die Innenablage.
- Überlasten Sie den internen Liftsockel NICHT.
- Springen Sie NICHT auf das Produkt oder eines seiner Teile.

## Français

### IMPORTANT POUR LES LITS À RELEVAGE DE GAZ&MAINTENANCE

- Veuillez placer le matelas sur le dessus du cadre de lit.
- Ne tirez pas sur les poignées de la sangle.
- Appuyez fortement pour libérer le gaz comprimé.
- Vérifiez régulièrement que toutes les vis et fixations sont bien en place.
- Lorsque vous déplacez votre produit, soulevez-le avec précaution pour le mettre en place.
- Nettoyez avec un chiffon légèrement humide - n'utilisez pas de produits chimiques abrasifs ou d'eau de Javel.
- Ne laissez pas les enfants utiliser le mécanisme de levage.
- Ne laissez pas les enfants s'approcher de la base de levage lorsqu'ils actionnent le mécanisme.
- Ne vous tenez PAS à l'intérieur du lit ou de la base de stockage interne.
- Ne surchargez pas la base de stockage interne.
- Ne pas sauter sur le produit ou l'une de ses parties.

## Italiano

### IMPORTANTE PER I LETTI CON SOLLEVAMENTO A GAS E LA MANUTENZIONE

- Posizionare il materasso sopra la struttura del letto.
- Non tirare le maniglie della cinghia.
- Premere con forza per rilasciare il gas compresso.
- Controllare periodicamente tutte le viti e i fissaggi per assicurarsi che siano saldi.
- Quando si sposta il prodotto, sollevarlo con cautela.
- Pulire con un panno leggermente umido, senza usare prodotti chimici abrasivi o candeggina.
- NON permettere ai bambini di azionare il meccanismo di sollevamento.
- NON permettere ai bambini di avvicinarsi alla base di sollevamento quando si aziona il meccanismo.
- NON sostare all'interno del letto o della base di contenimento interna.
- NON sovraccaricare la base di contenimento interna.
- NON saltare sul prodotto o sulle sue parti.

## Español

### IMPORTANTE PARA LAS CAMAS ELEVADORAS DE GAS&MANTENIMIENTO

- Coloque el colchón sobre el somier.
- No tire de las asas de la correa.
- Presione con fuerza para liberar el gas comprimido.
- Compruebe periódicamente que todos los tornillos y fijaciones estén bien sujetos.
- Al mover el producto, levántelo con cuidado para colocarlo en su sitio.
- Limpie con un paño ligeramente humedecido; no utilice productos químicos abrasivos ni lejía.
- NO permita que los niños accionen el mecanismo de elevación.
- NO permita que los niños se acerquen a la base elevadora cuando accionen el mecanismo.
- NO se ponga de pie dentro de la cama o de la base de almacenamiento interna.
- NO sobrecargue el somier.
- NO salte sobre el producto ni sobre ninguna de sus piezas.

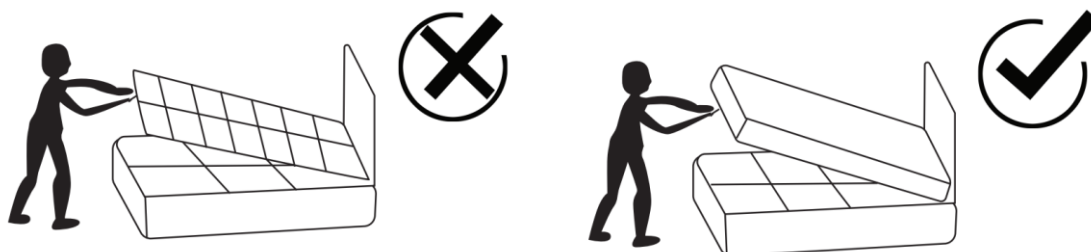

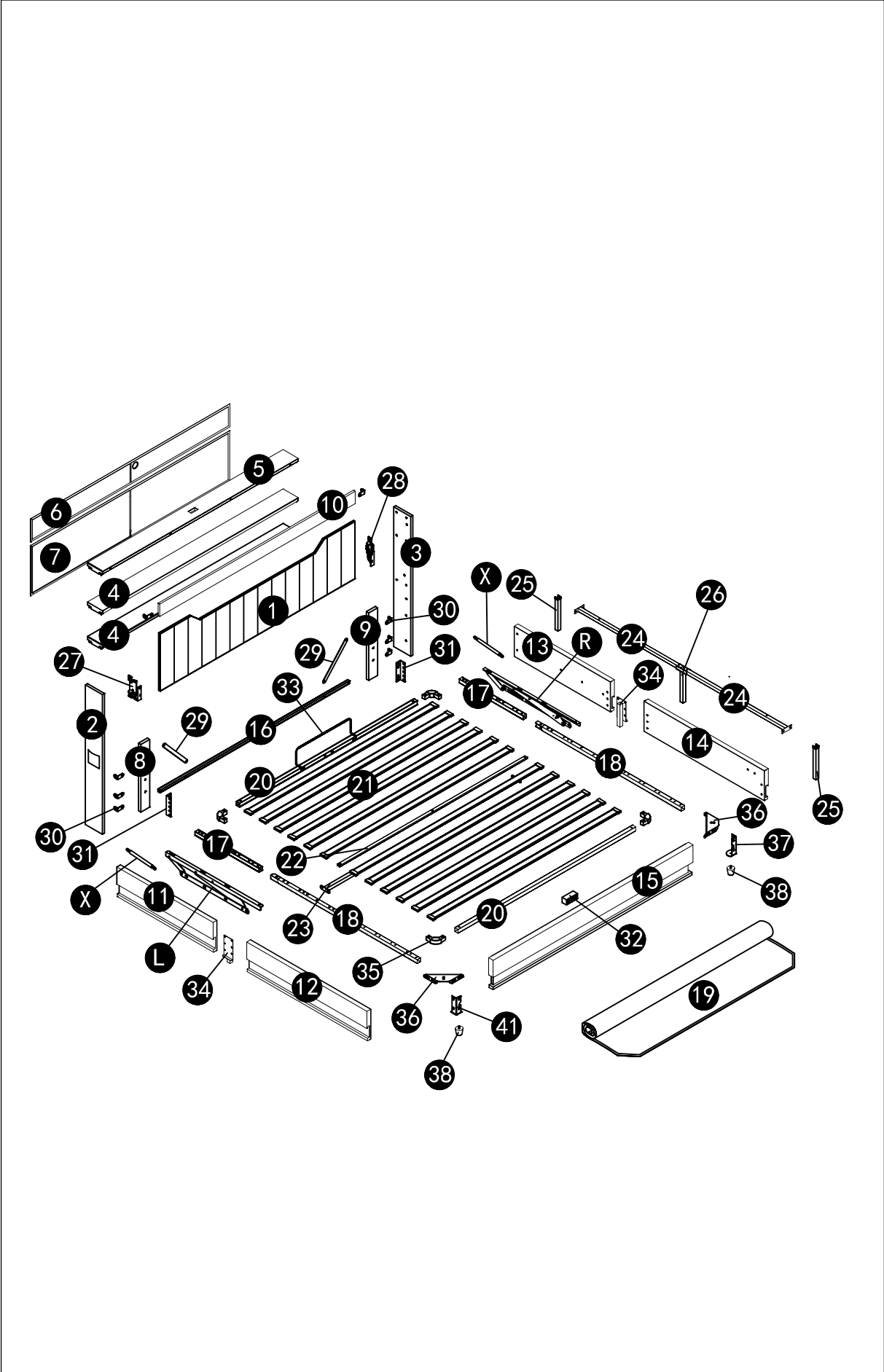

N601P369579

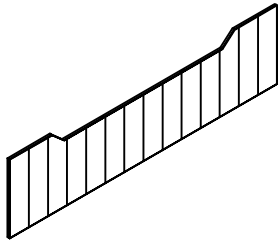
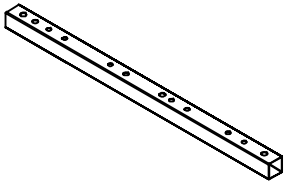
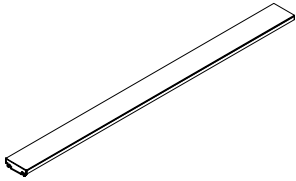
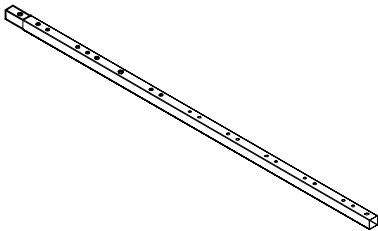
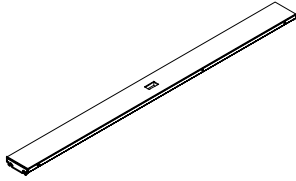
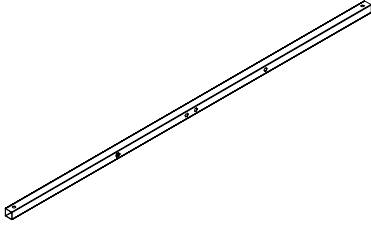
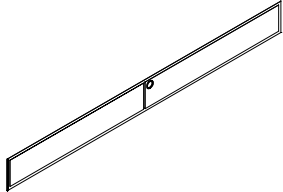
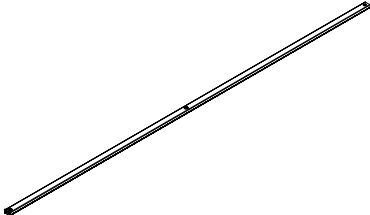
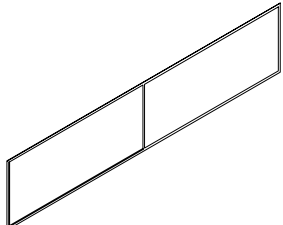
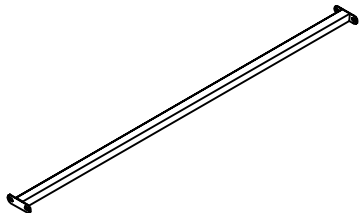
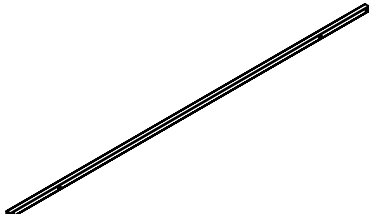
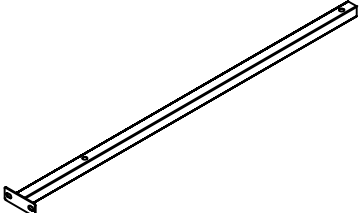
<p>1</p>		<p>X1</p>	<p>17</p>		<p>X2</p>
<p>4</p>		<p>X2</p>	<p>18</p>		<p>X2</p>
<p>5</p>		<p>X1</p>	<p>20</p>		<p>X2</p>
<p>6</p>		<p>X1</p>	<p>22</p>		<p>X1</p>
<p>7</p>		<p>X1</p>	<p>23</p>		<p>X1</p>
<p>16</p>		<p>X1</p>	<p>24</p>		<p>X2</p>

N601P369579

33

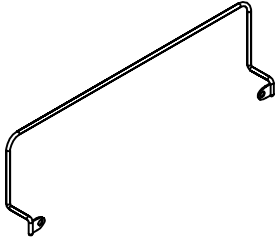



X1

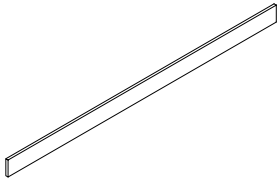
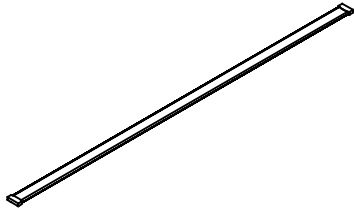
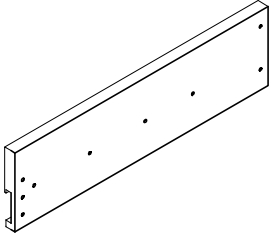
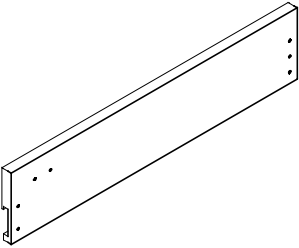
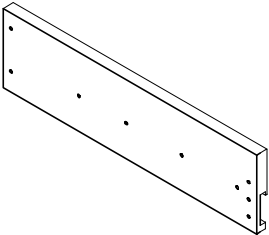
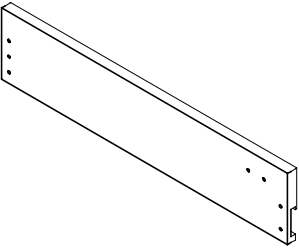
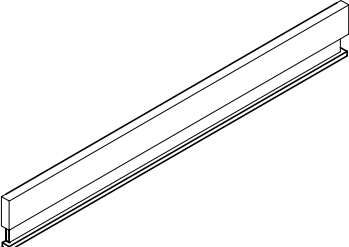

N601P369580

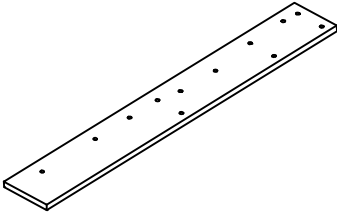
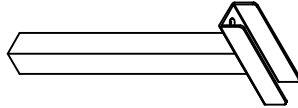
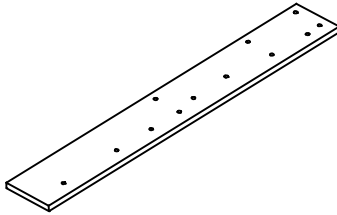
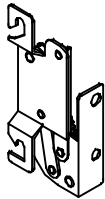
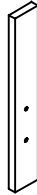
<p><b>10</b></p>		<p>X1</p>	<p><b>21</b></p>		<p>X12</p>
<p><b>11</b></p>		<p>X1</p>			
<p><b>12</b></p>		<p>X1</p>			
<p><b>13</b></p>		<p>X1</p>			
<p><b>14</b></p>		<p>X1</p>			
<p><b>15</b></p>		<p>X1</p>			

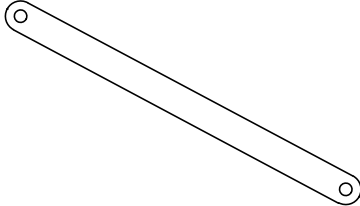
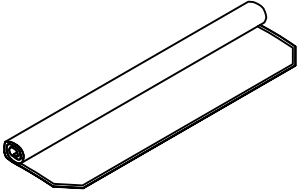
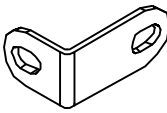
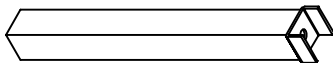
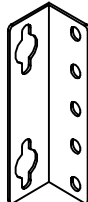



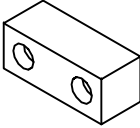
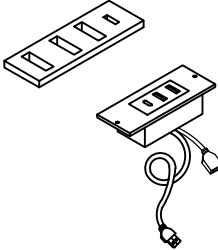

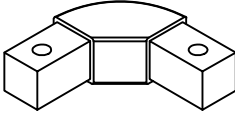
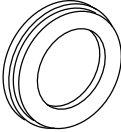
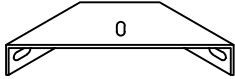
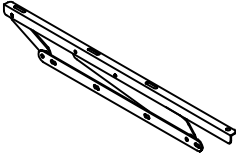
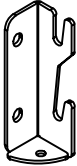
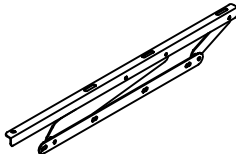
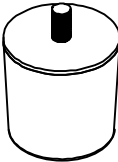

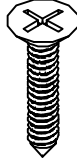

N601P369581

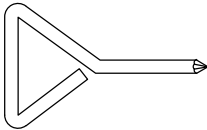
<p><b>2</b></p>		<p>X1</p>	<p><b>26</b></p>		<p>X1</p>
<p><b>3</b></p>		<p>X1</p>	<p><b>27</b></p>		<p>X1</p>
<p><b>8</b></p>		<p>X1</p>	<p><b>28</b></p>		<p>X1</p>
<p><b>9</b></p>		<p>X1</p>	<p><b>29</b></p>		<p>X2</p>
<p><b>19</b></p>		<p>X1</p>	<p><b>30</b></p>		<p>X8</p>
<p><b>25</b></p>		<p>X2</p>	<p><b>31</b></p>		<p>X2</p>

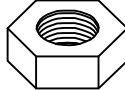

N601P369581

<p>32</p>		<p>X1</p>	<p>39</p>		<p>X1</p>
<p>34</p>		<p>X2</p>	<p>41</p>		<p>X1</p>
<p>35</p>		<p>X4</p>	<p>42</p>		<p>X1</p>
<p>36</p>		<p>X2</p>	<p>L</p>		<p>X1</p>
<p>37</p>		<p>X1</p>	<p>R</p>		<p>X1</p>
<p>38</p>		<p>X2</p>			

N601P369581

<p><b>A</b></p>	 <p>M8*12</p>	<p>X8+1</p>	<p><b>H</b></p>	 <p>M4*12</p>	<p>X2+1</p>
<p><b>B</b></p>	 <p>M8*15</p>	<p>X42+2</p>	<p><b>I</b></p>	 	<p>X1</p>
<p><b>C</b></p>	 <p>M8*20</p>	<p>X48+2</p>	<p><b>J</b></p>	 <p>M8</p>	<p>X12+1</p>
<p><b>D</b></p>	 <p>M8*35</p>	<p>X4+1</p>	<p><b>L</b></p>	 <p>M6</p>	<p>X1</p>
<p><b>E</b></p>	 <p>M8*40</p>	<p>X4+1</p>	<p><b>N</b></p>	 <p>M6*20</p>	<p>X4+1</p>
<p><b>F</b></p>	 <p>M8*50</p>	<p>X9+1</p>	<p><b>M</b></p>	 <p>M6*15</p>	<p>X2+1</p>

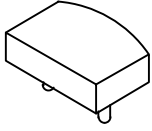
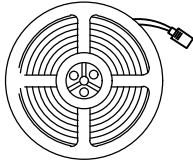
N601P369581

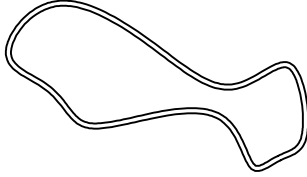
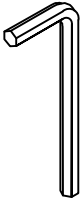
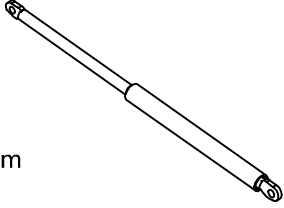
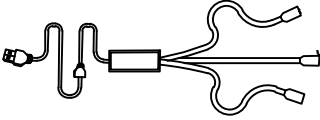
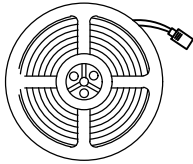
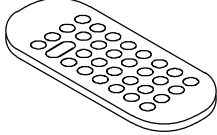
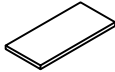
<p><b>P</b></p>		<p>X24</p>	<p><b>V</b></p>	 <p><b>Long light strip</b></p>	<p>X2</p>
<p><b>Q</b></p>		<p>X1</p>	<p><b>W</b></p>		<p>X1</p>
<p><b>R</b></p>	 <p>M8</p>	<p>X1</p>	<p><b>X</b></p>	 <p>380mm 9mm 750N</p>	<p>X2</p>
<p><b>S</b></p>	 <p><b>Power cord</b></p>	<p>X1</p>	<p><b>Z</b></p>	 <p><b>Short light strip</b></p>	<p>X1</p>
<p><b>T</b></p>	 <p><b>Remote control</b></p>	<p>X1</p>			
<p><b>U</b></p>		<p>X4</p>			

**1**



M8X20  
CX12pcs

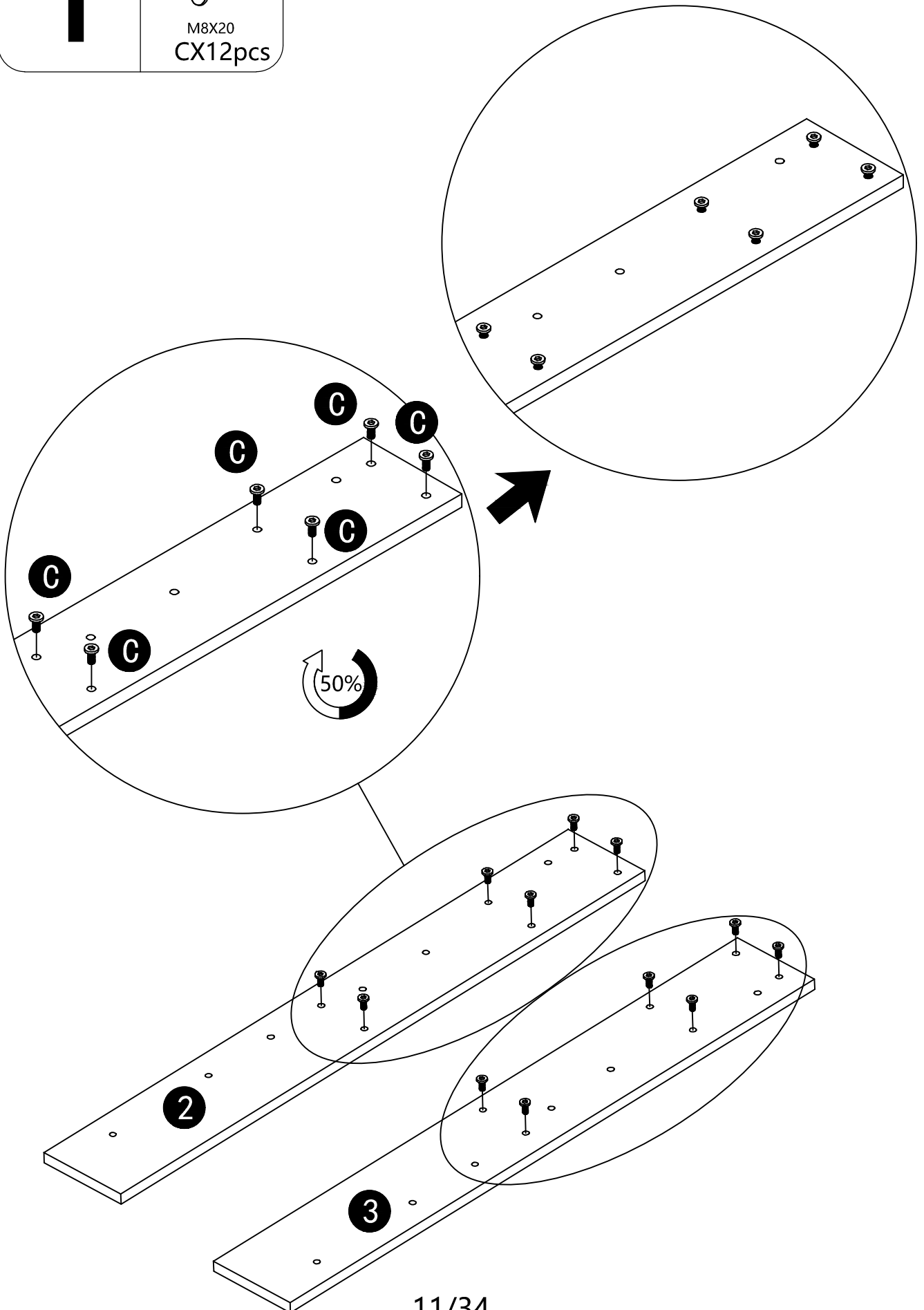

**2**

M4X12  
HX2pcs

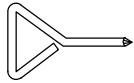

IX1pc

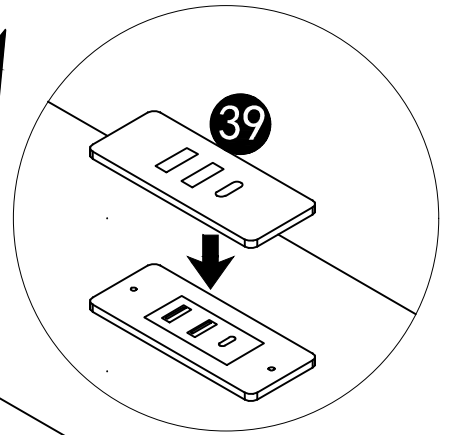
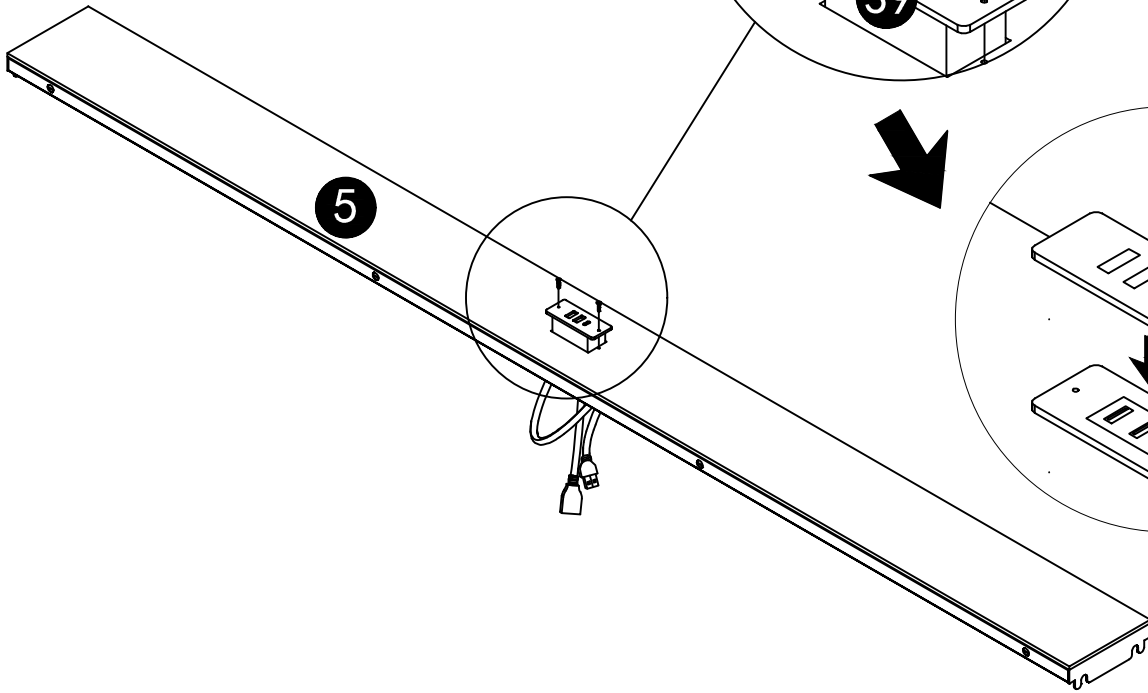

**3**

M6X20  
NX4pcs

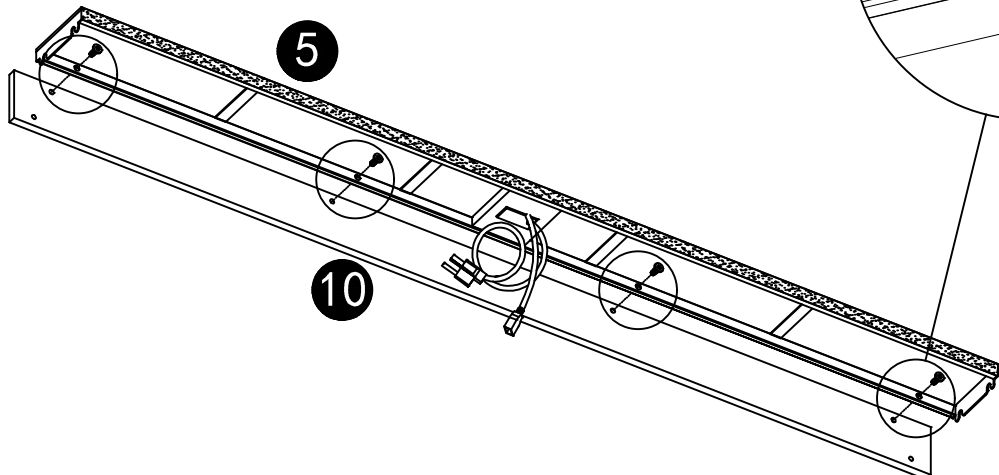

4

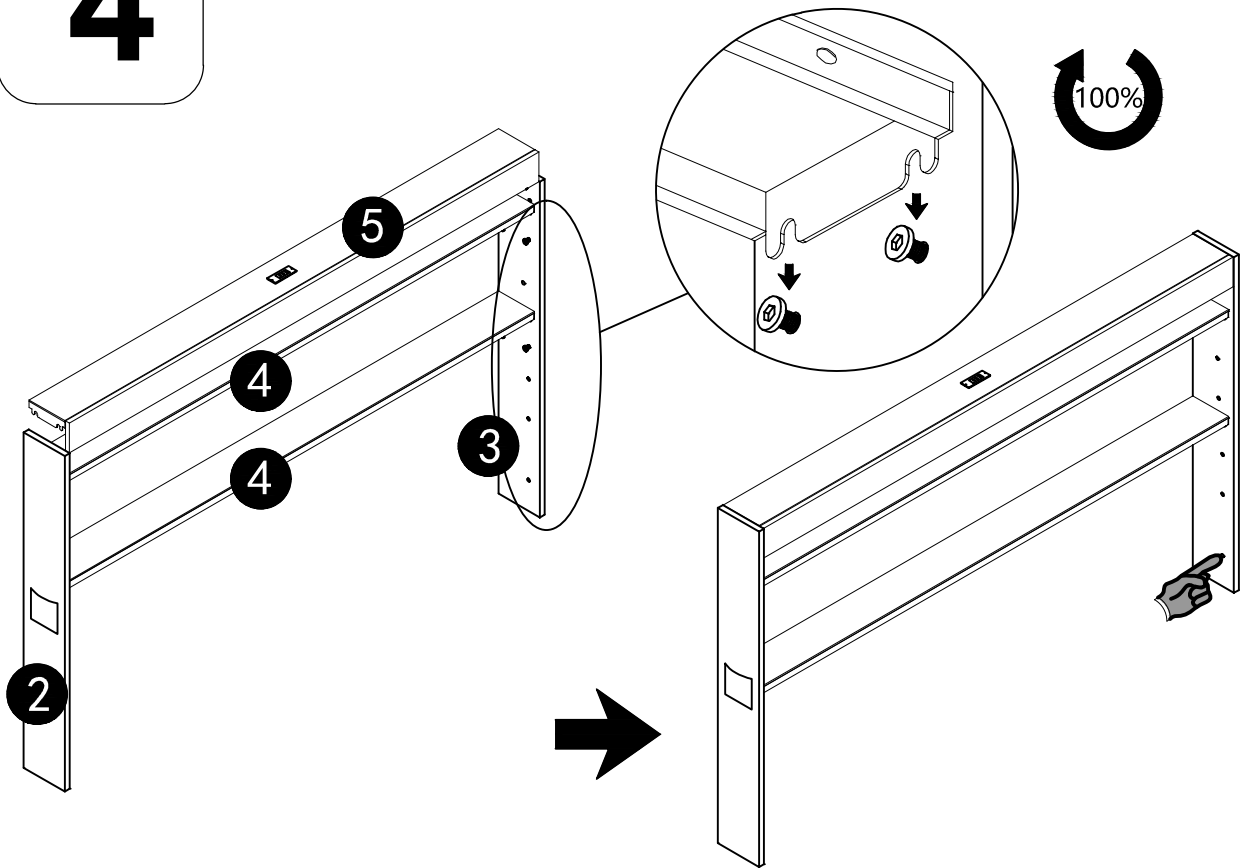

5

M8X20  
CX4pcs

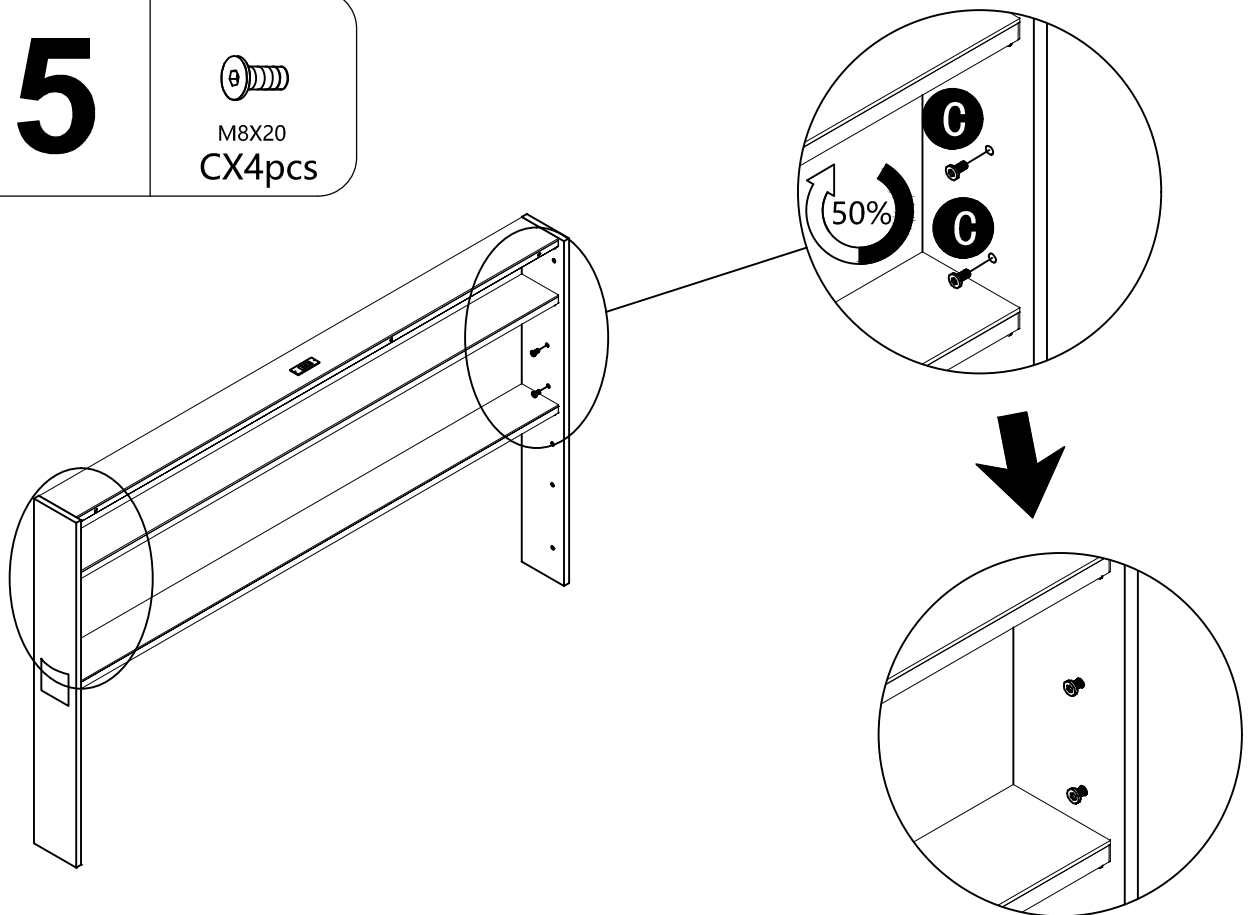

# 6

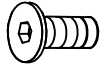

M8X15  
BX2pcs



M6X15  
MX2pcs

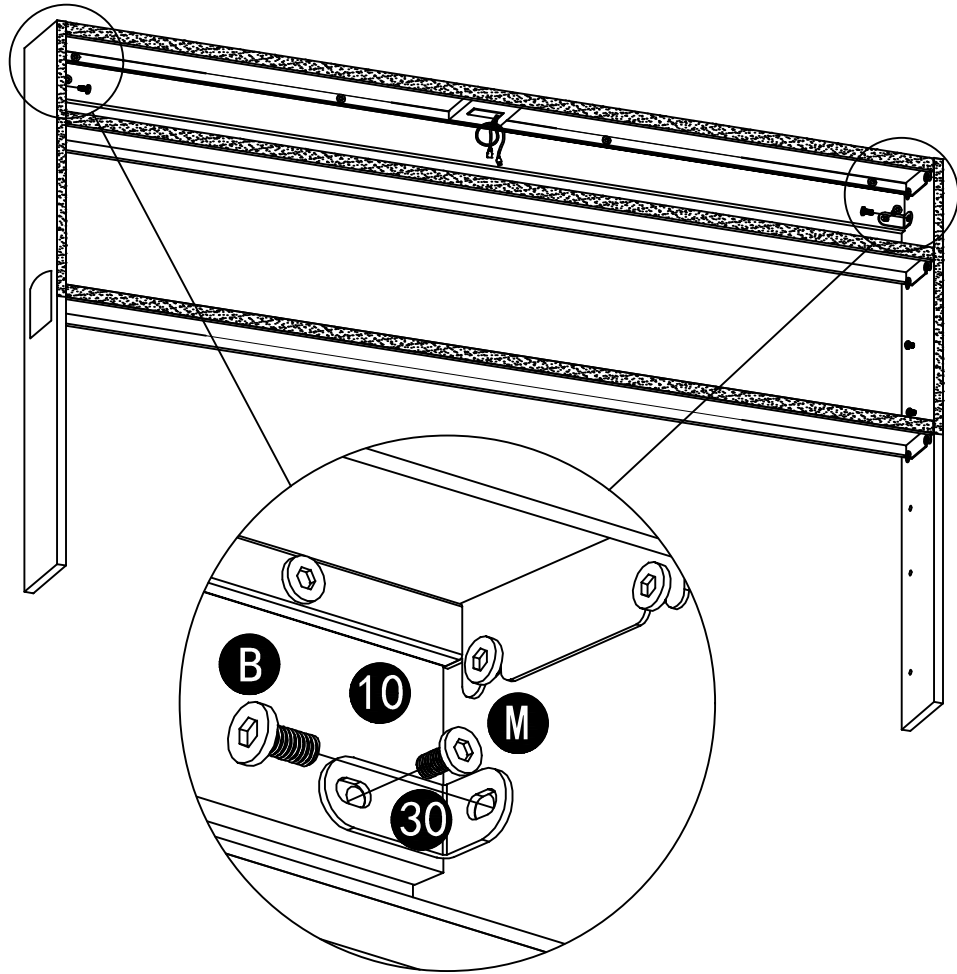

# 7

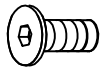

M8X15  
BX12pcs

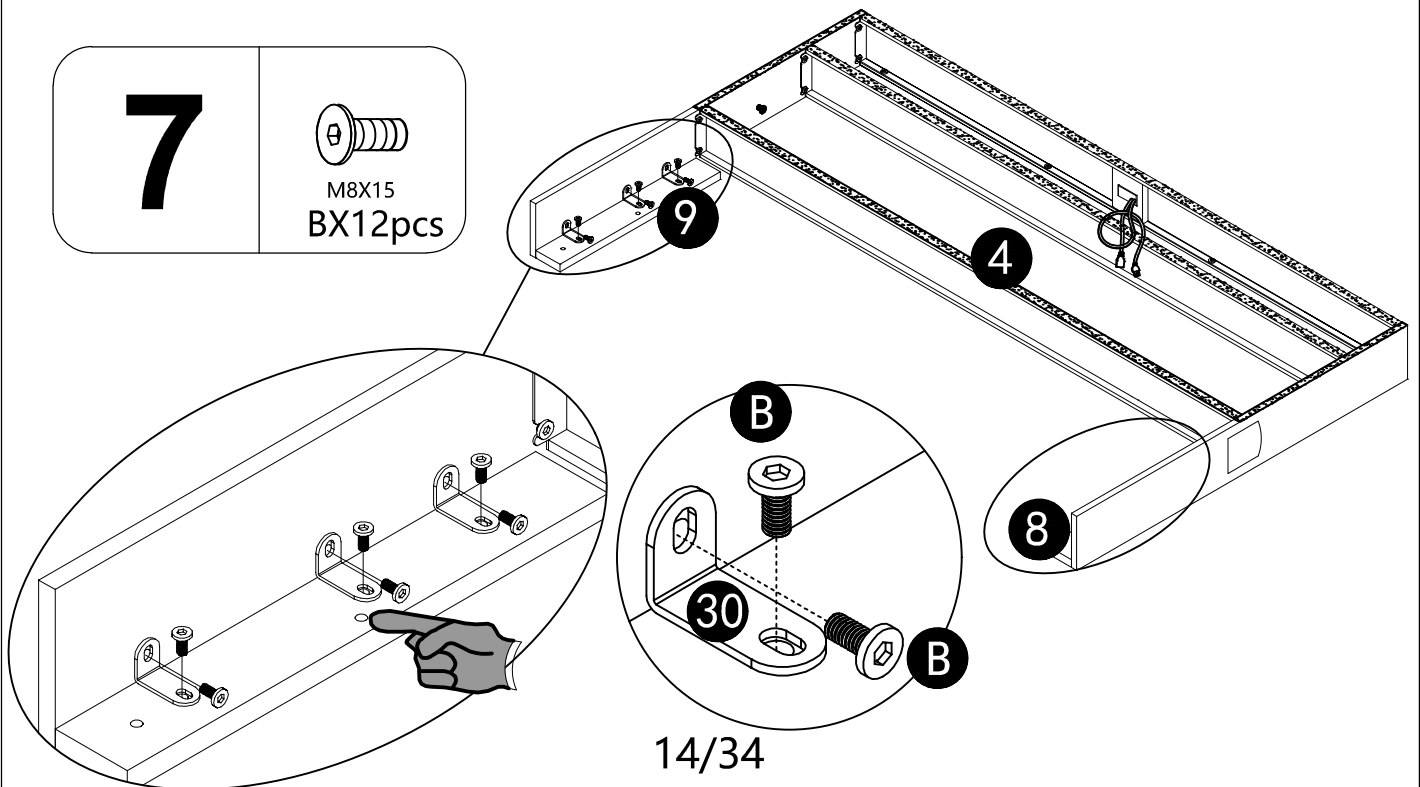

8

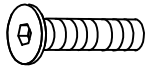

M8X40  
EX2pcs

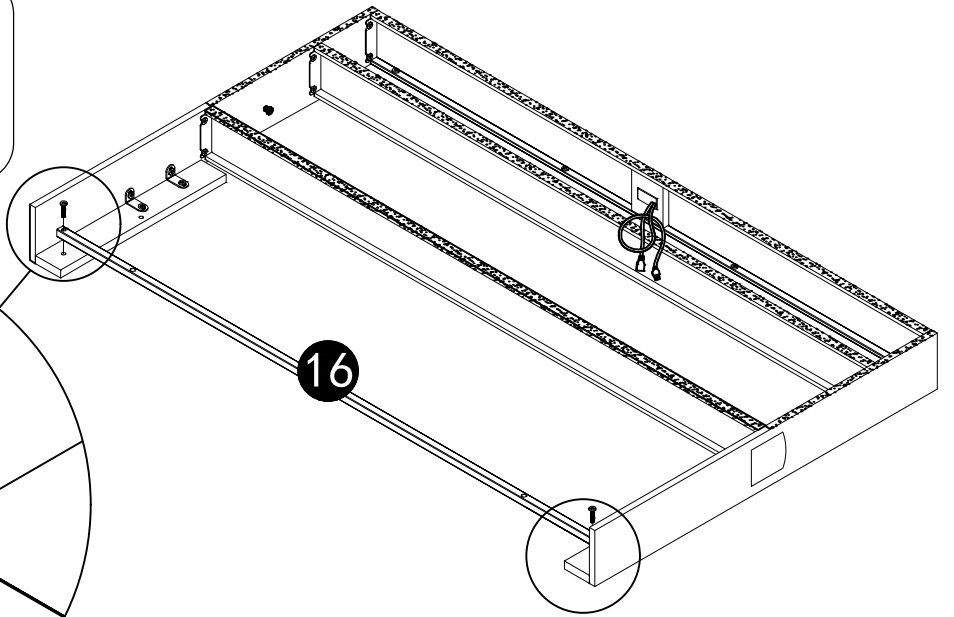
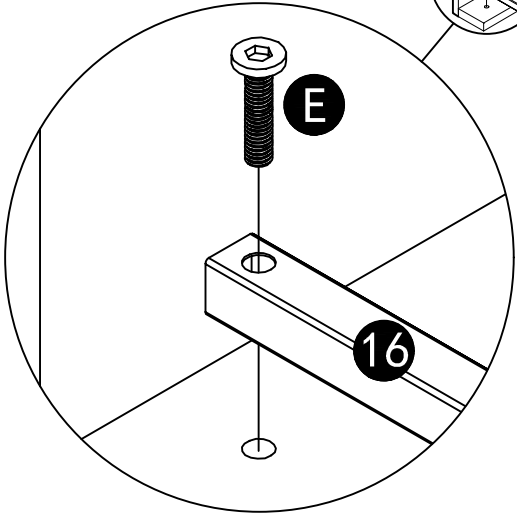

9

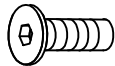

M8X20  
CX4pcs

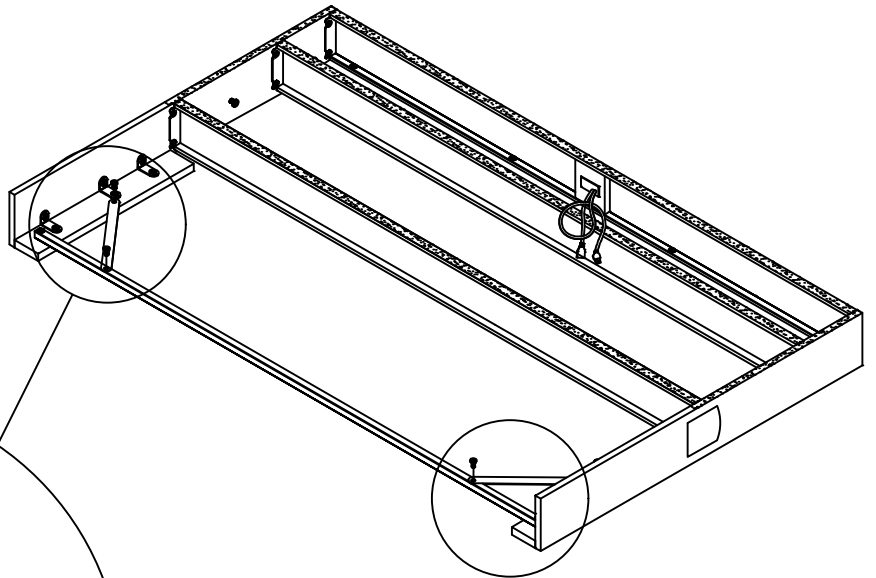
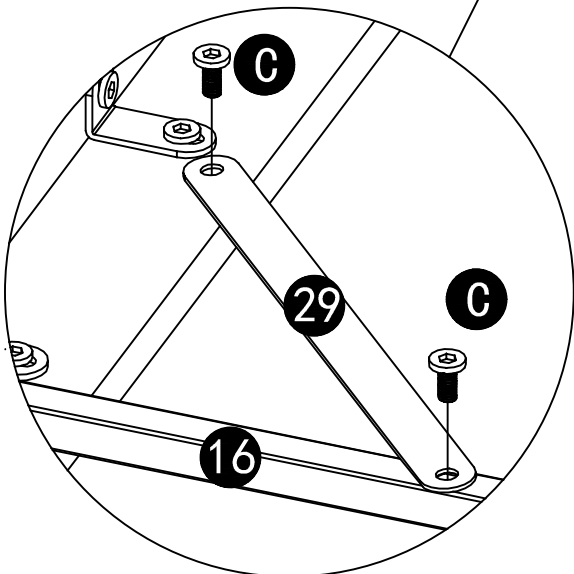

# 10



M8X15  
BX4pcs

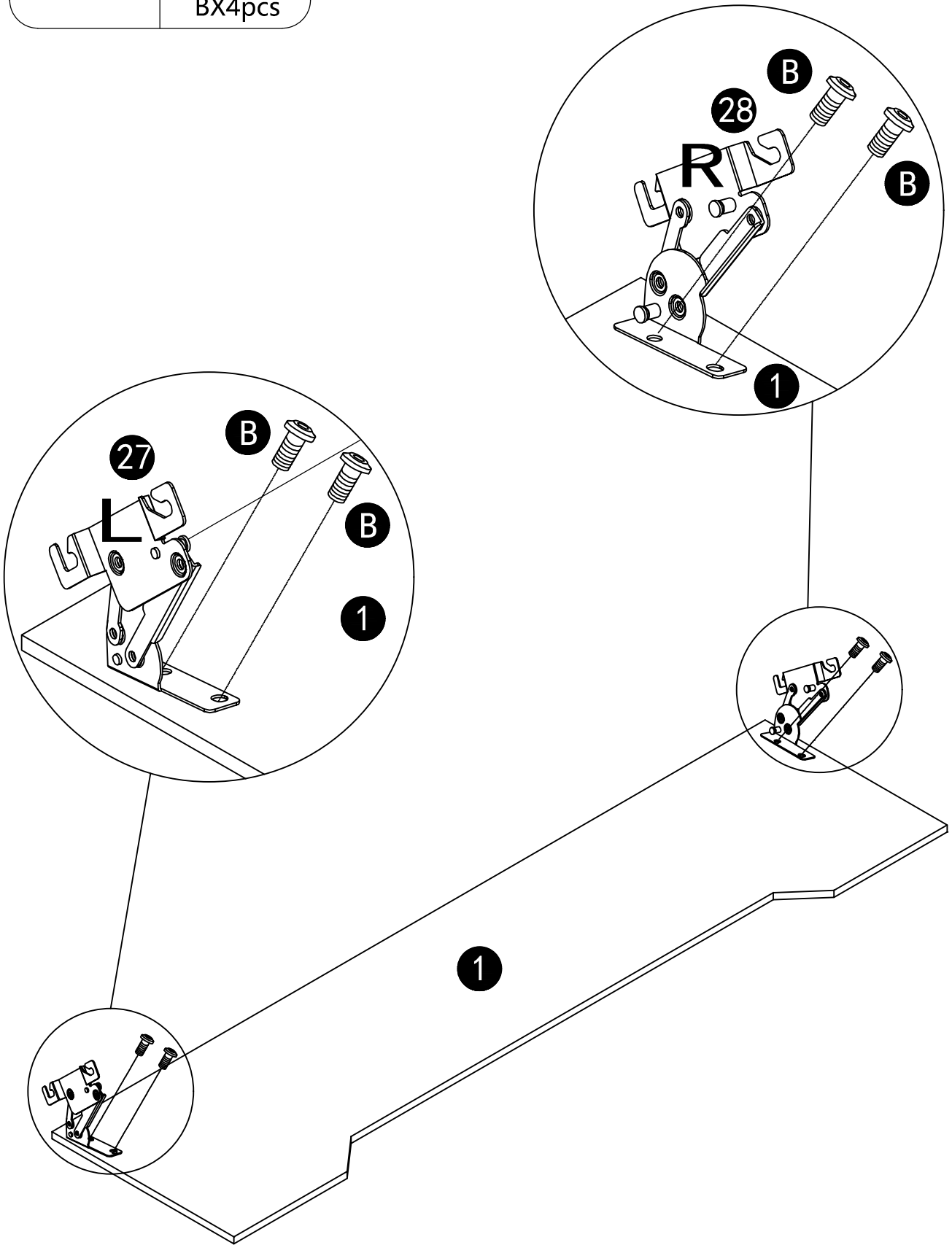

11

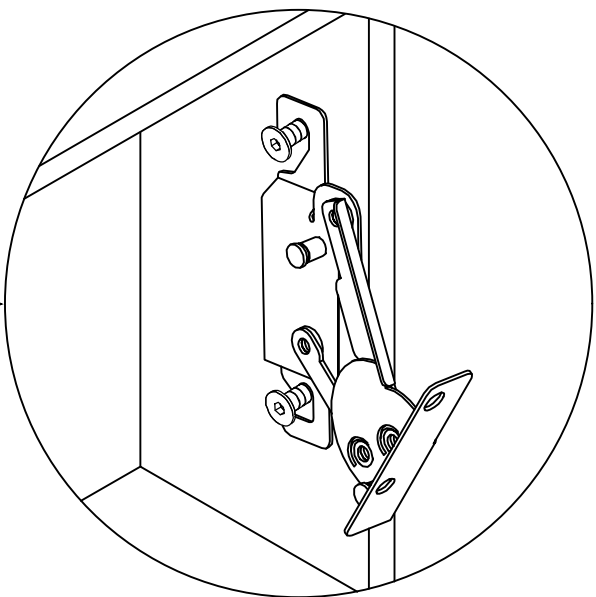
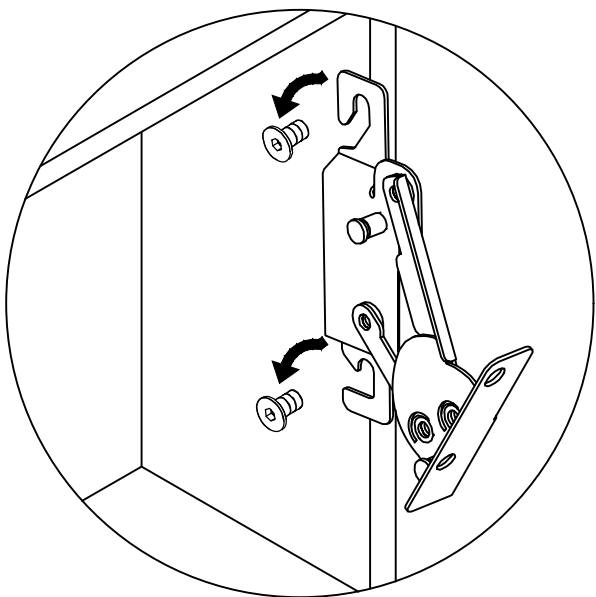
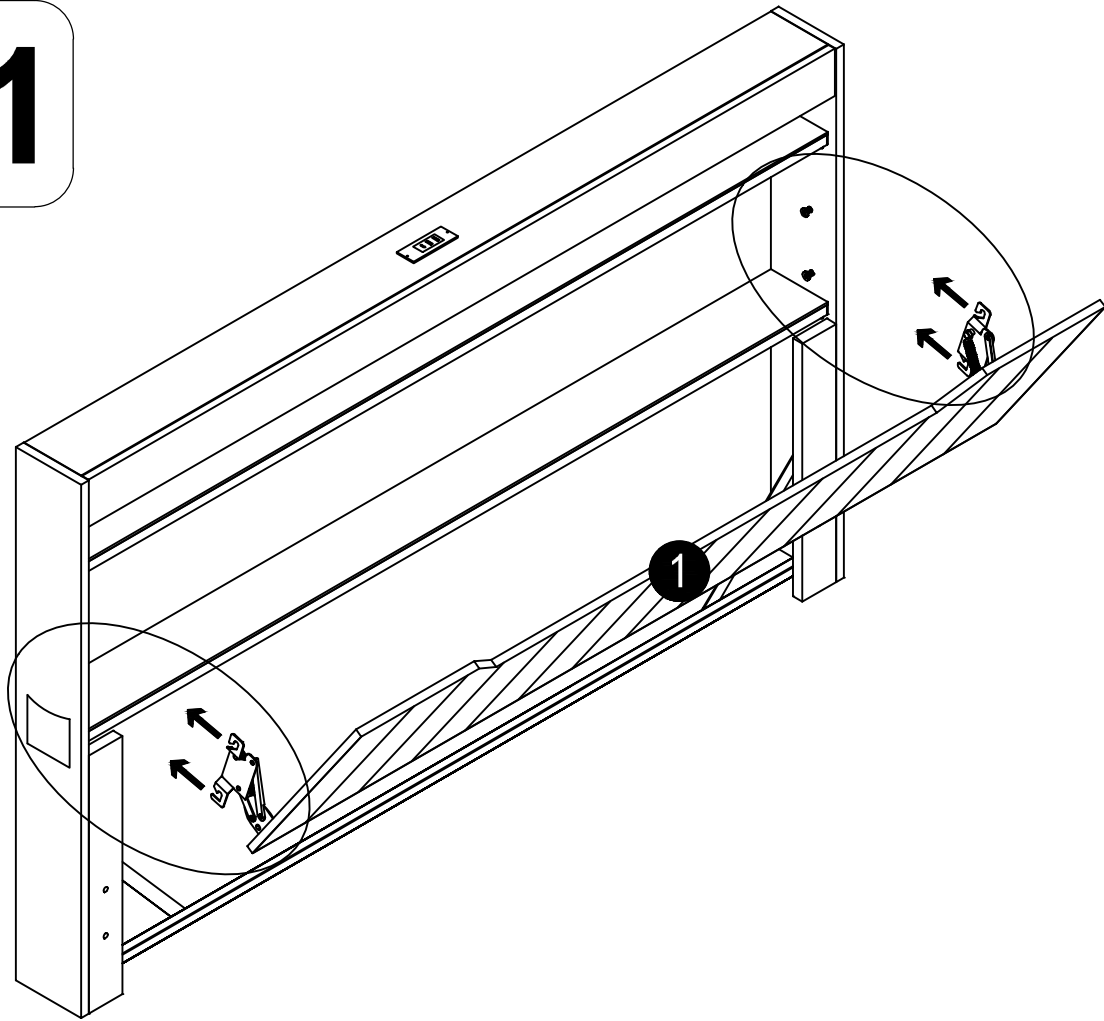

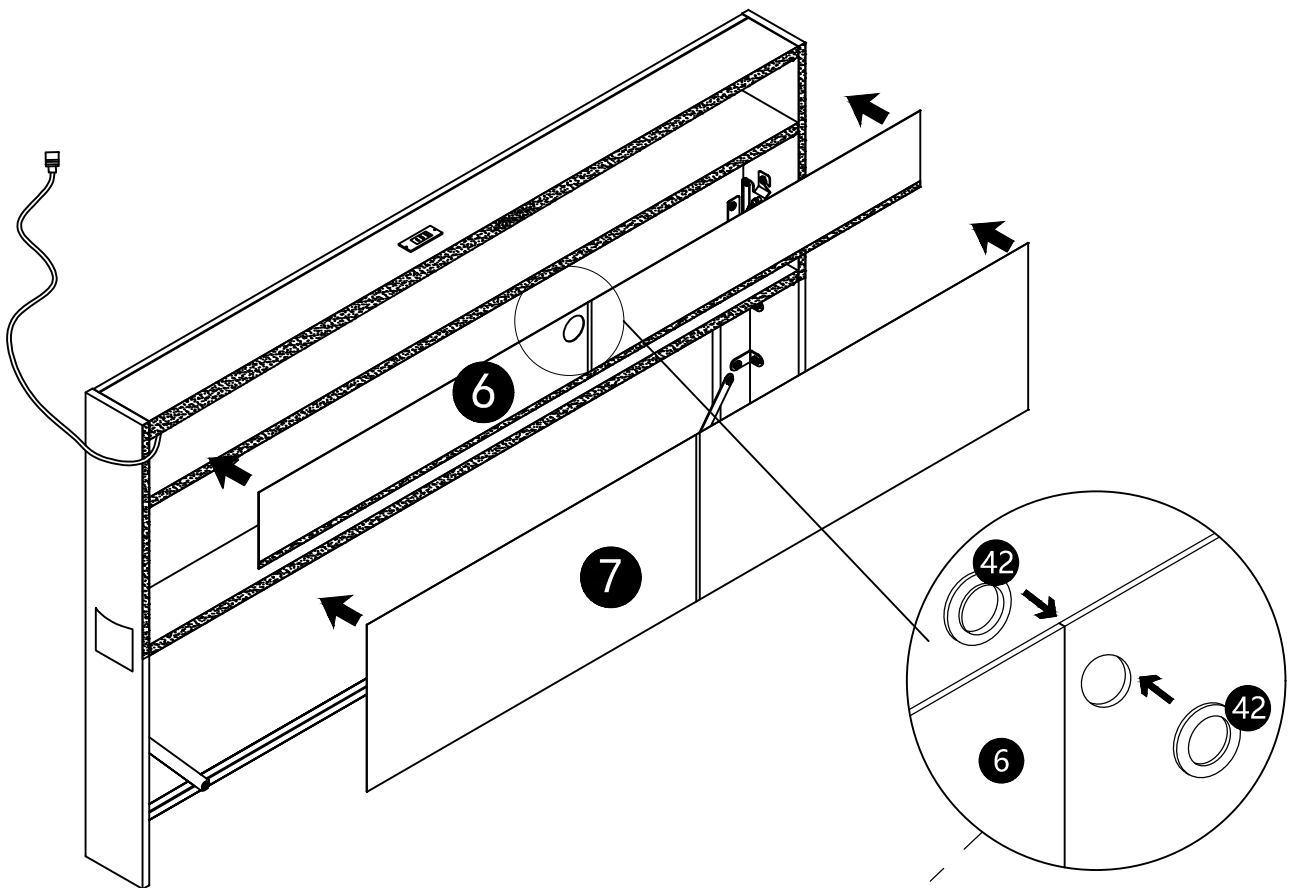
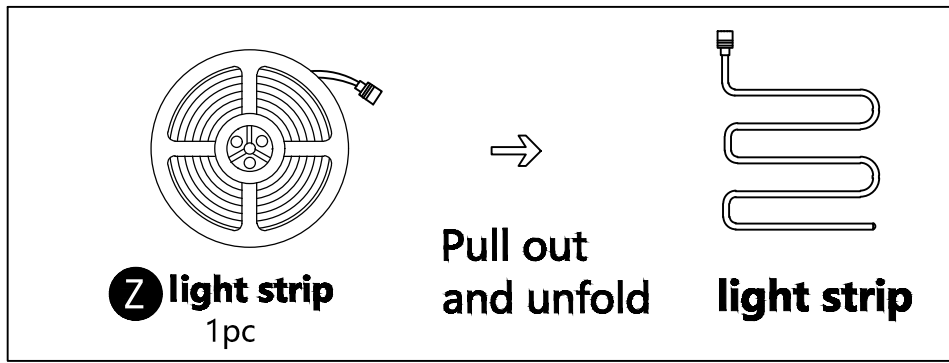

- NO.1 Open accessory( 42 )
- NO.2 Place them separately on the front and back of the ( 6 ) hole and press them tightly

# 12

M8X15  
BX8pcs

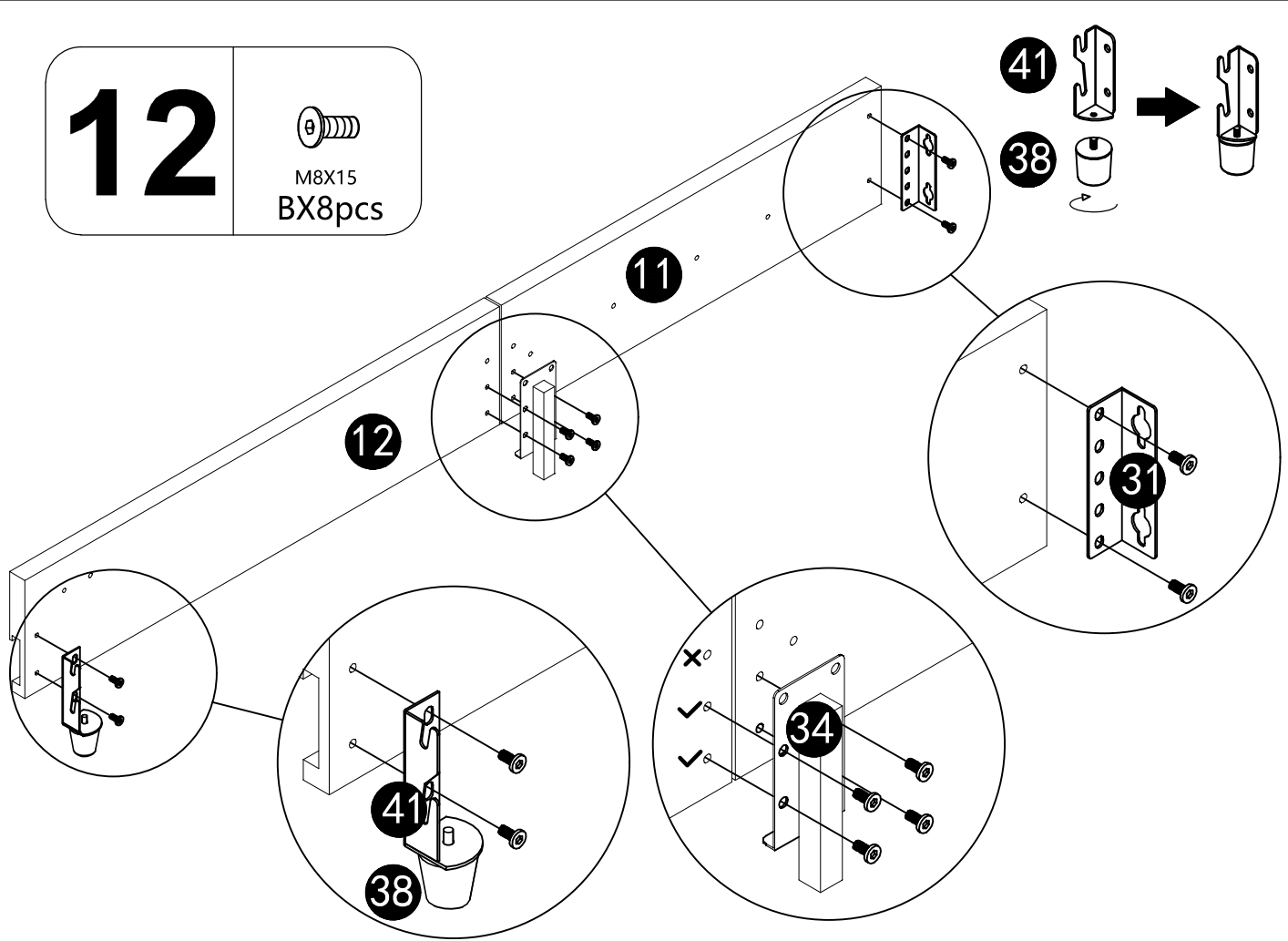

# 13

M8X15  
BX8pcs

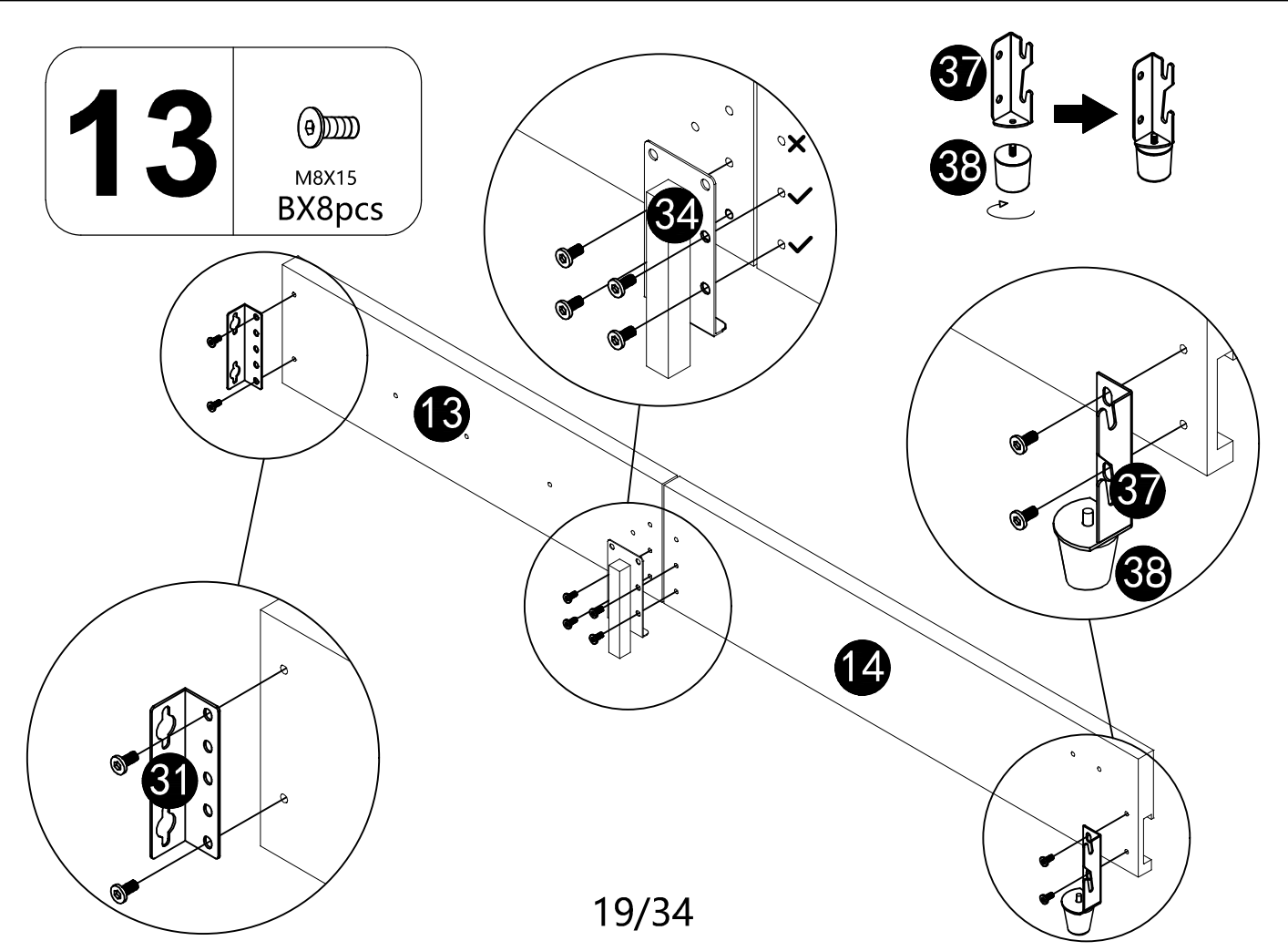

**14**

  
M8X20  
CX8pcs

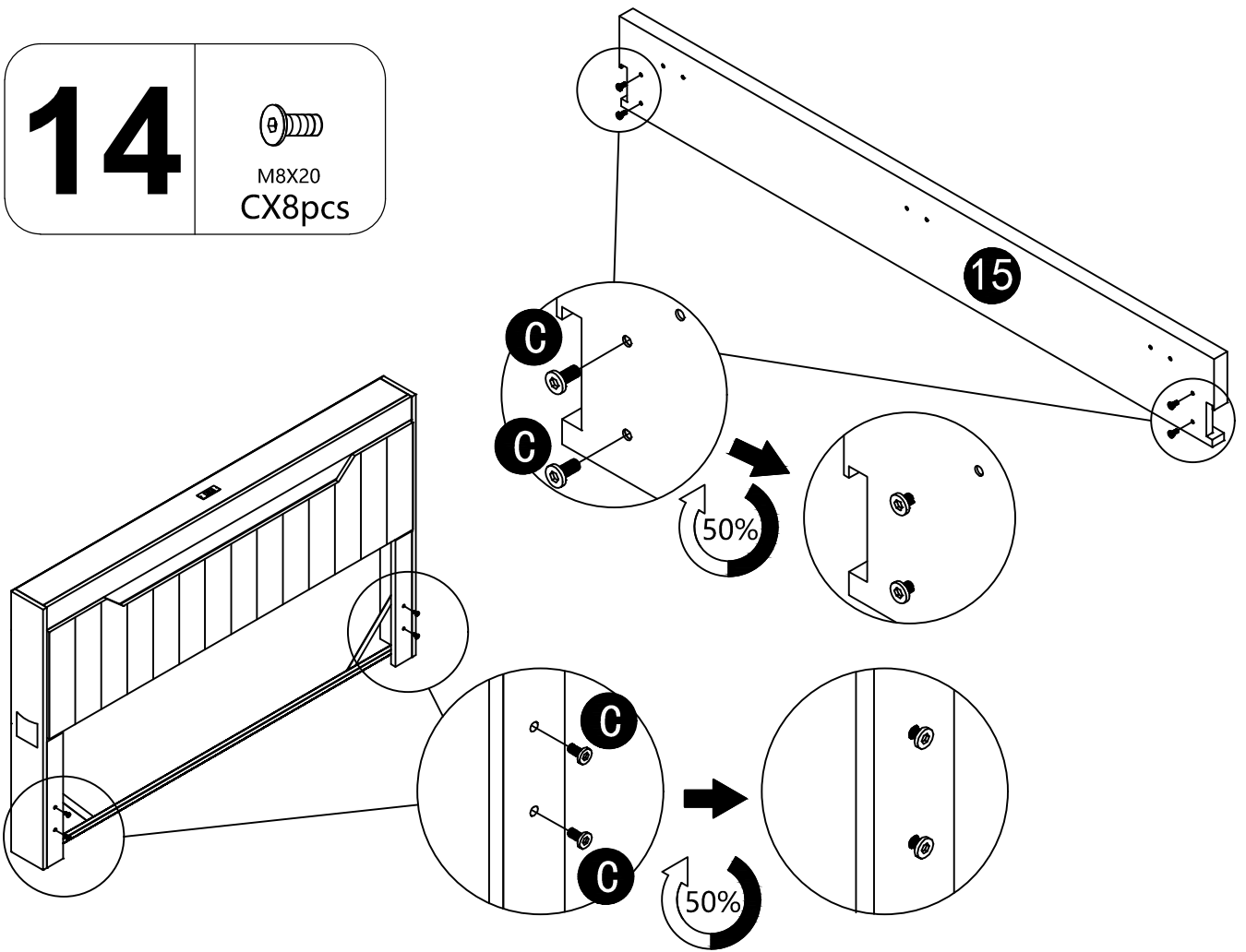

**15**

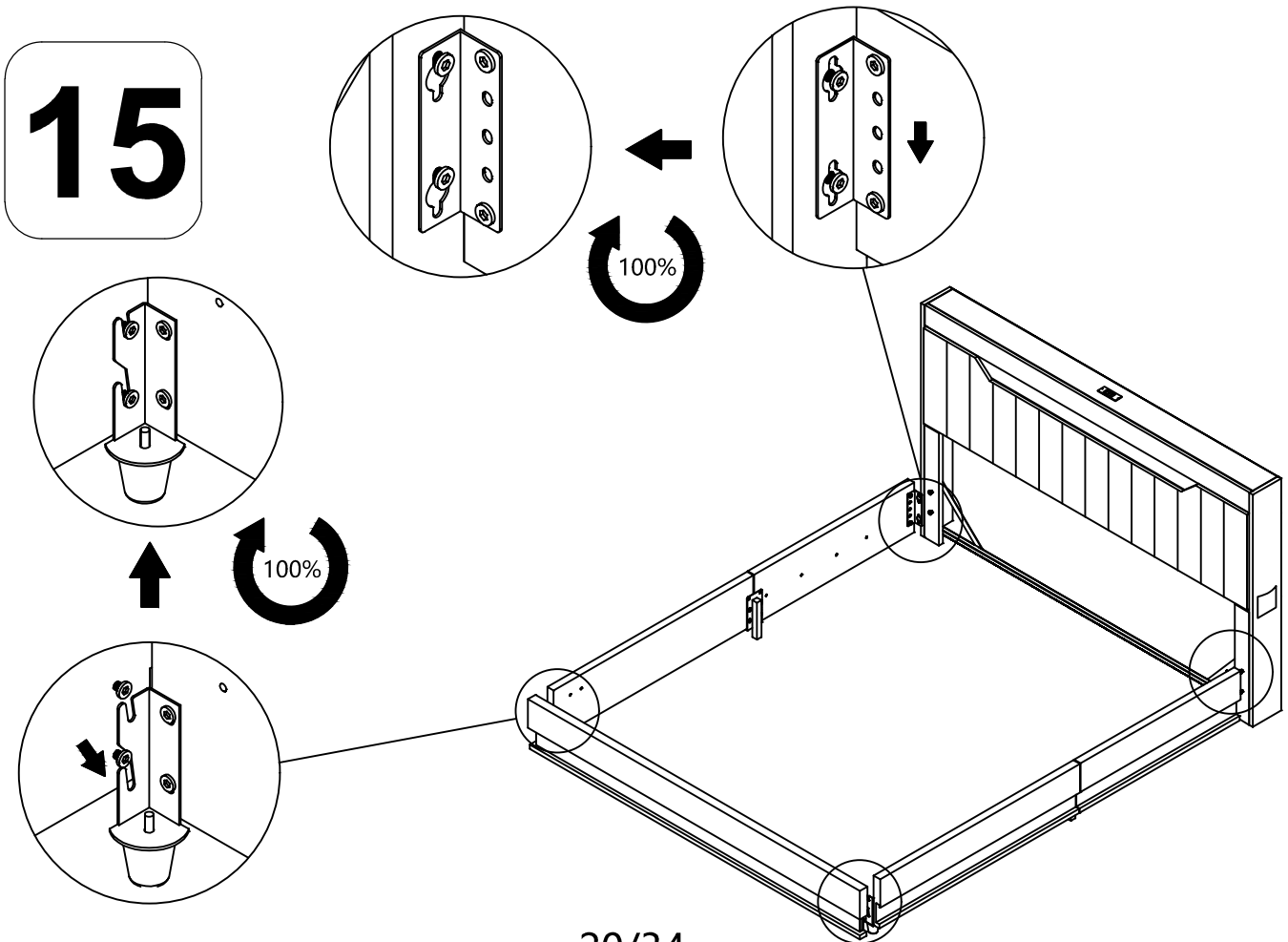

# 16

  
M8X20  
CX4pcs

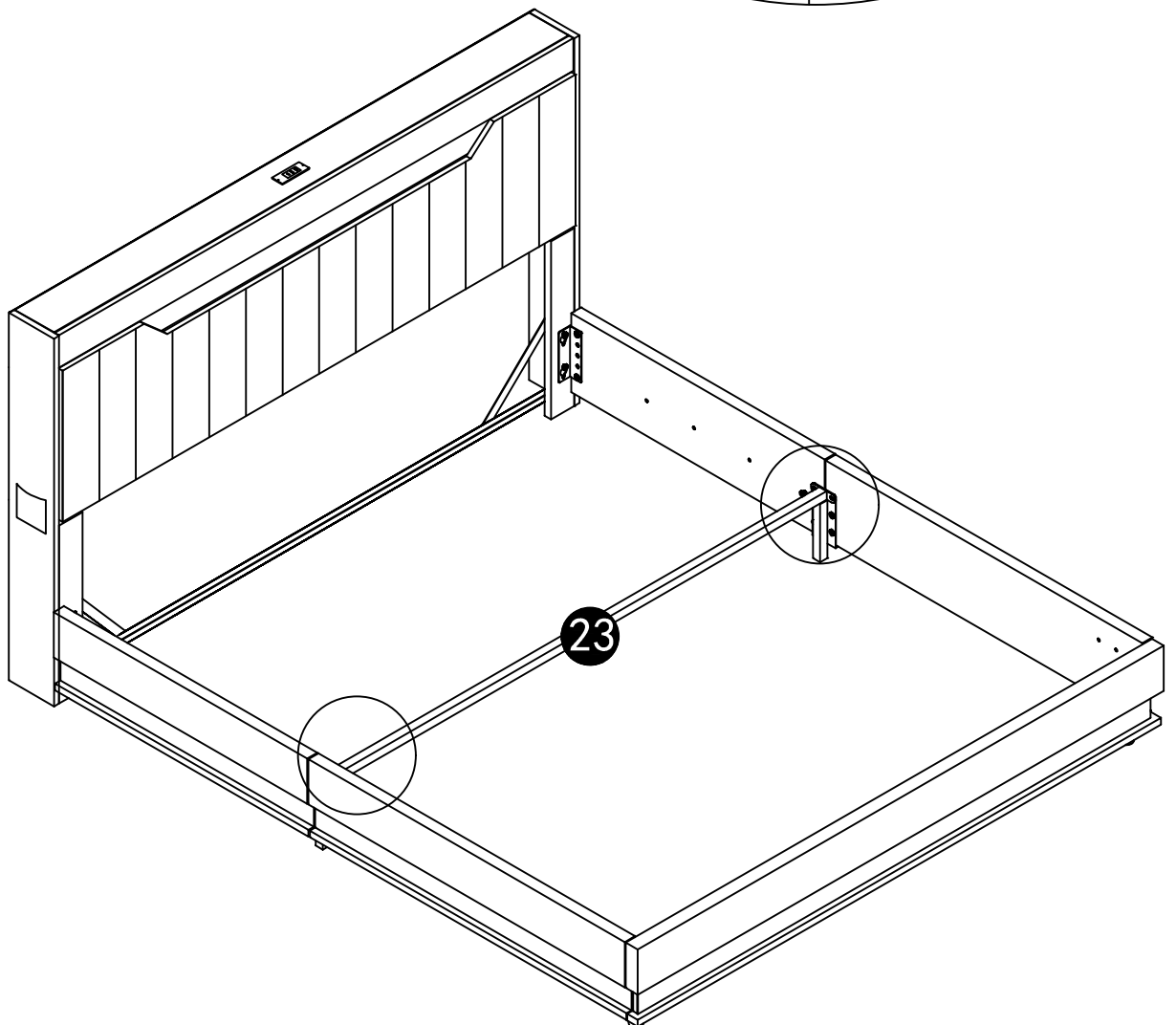
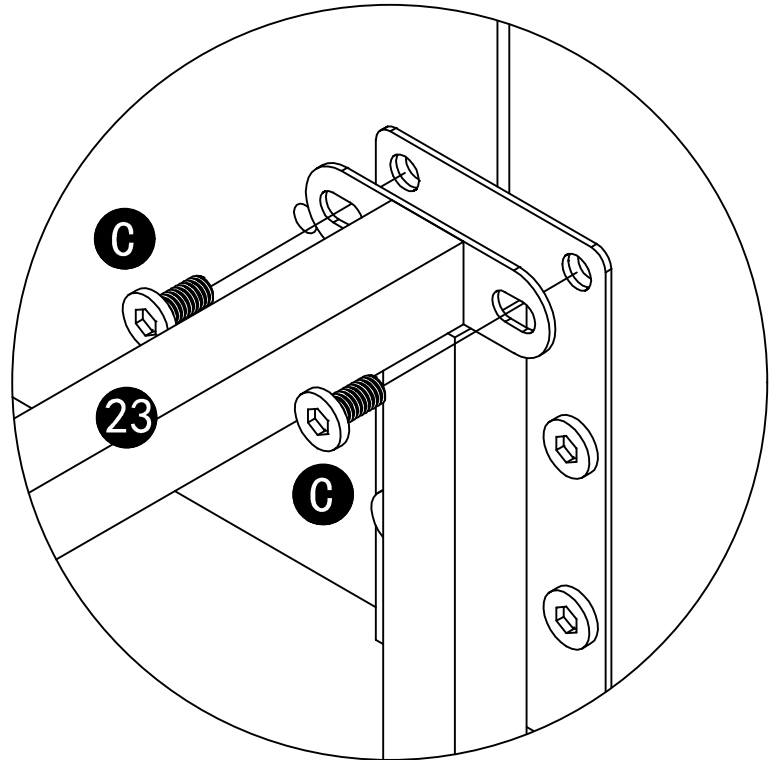

# 17

  
M8X20  
CX8pcs

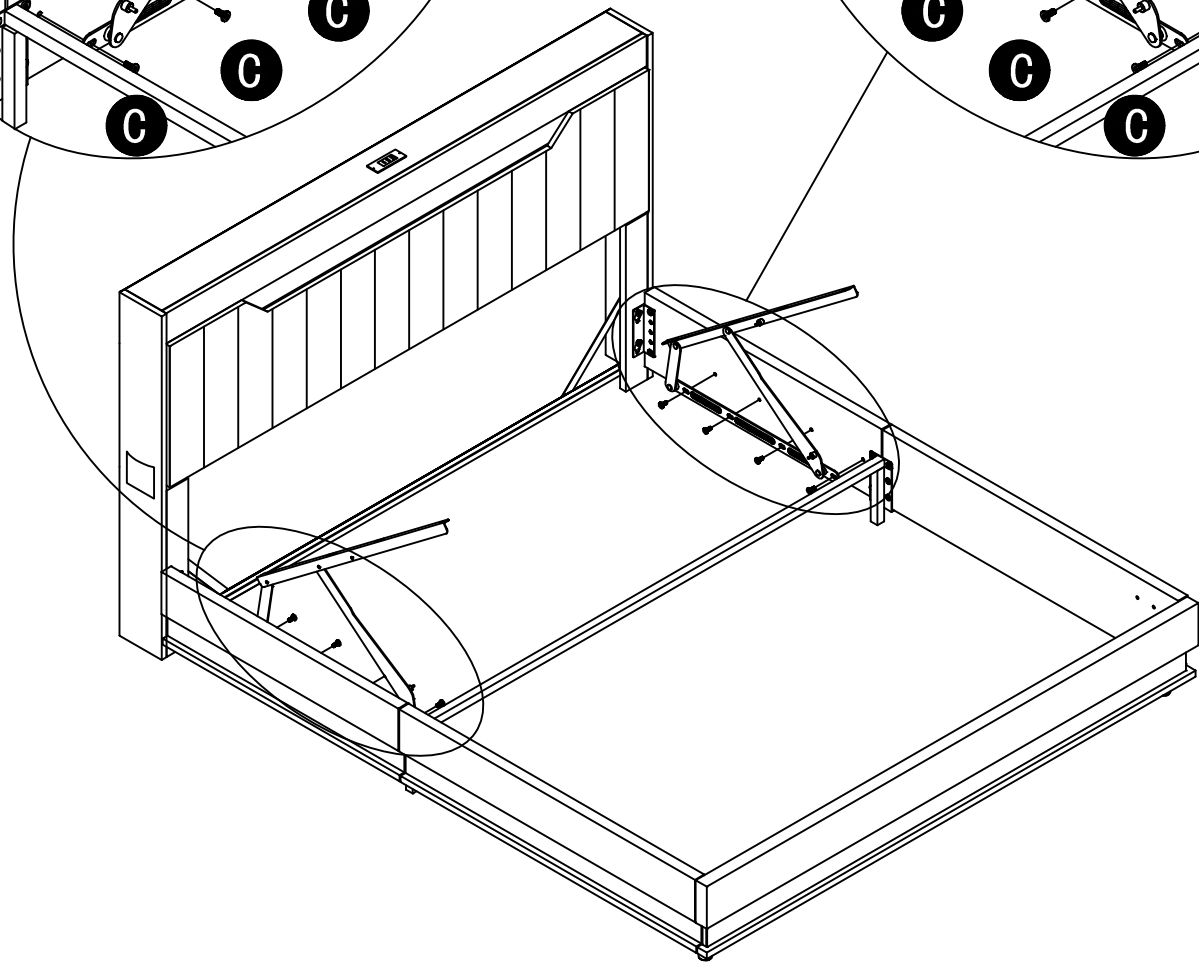
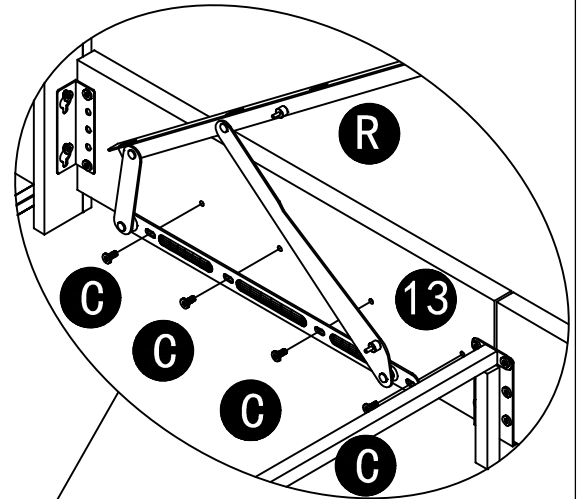
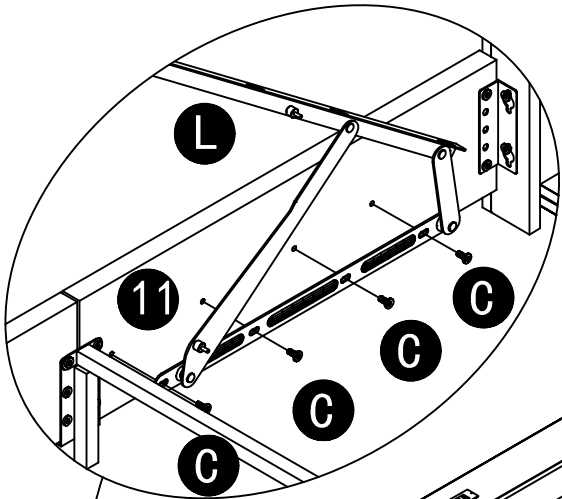
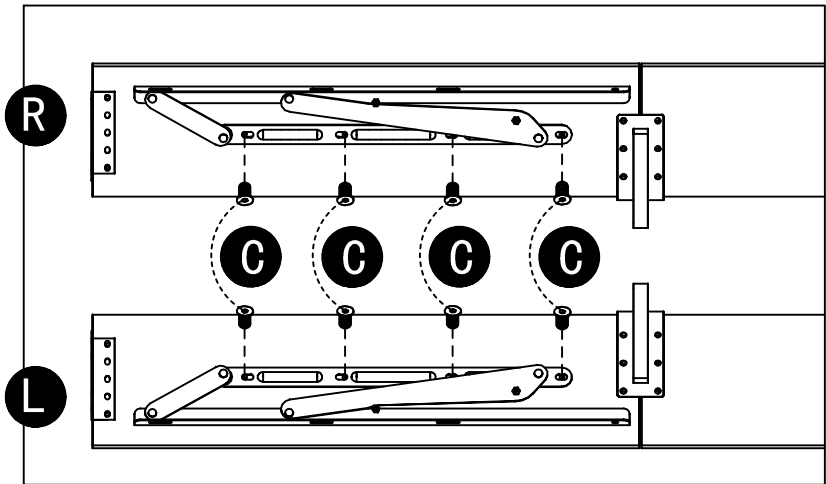

# 18

  
M8X15  
BX8pcs

  
M8X40  
EX2pcs

  
UX4pcs

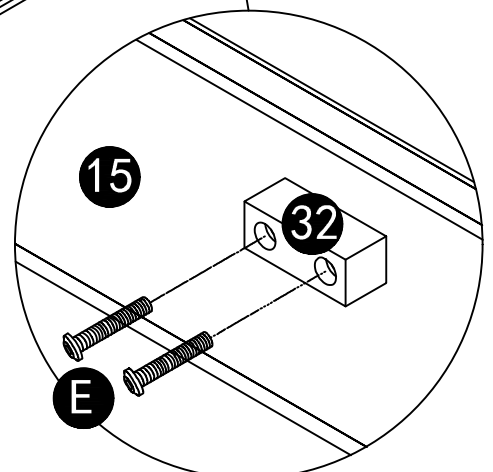
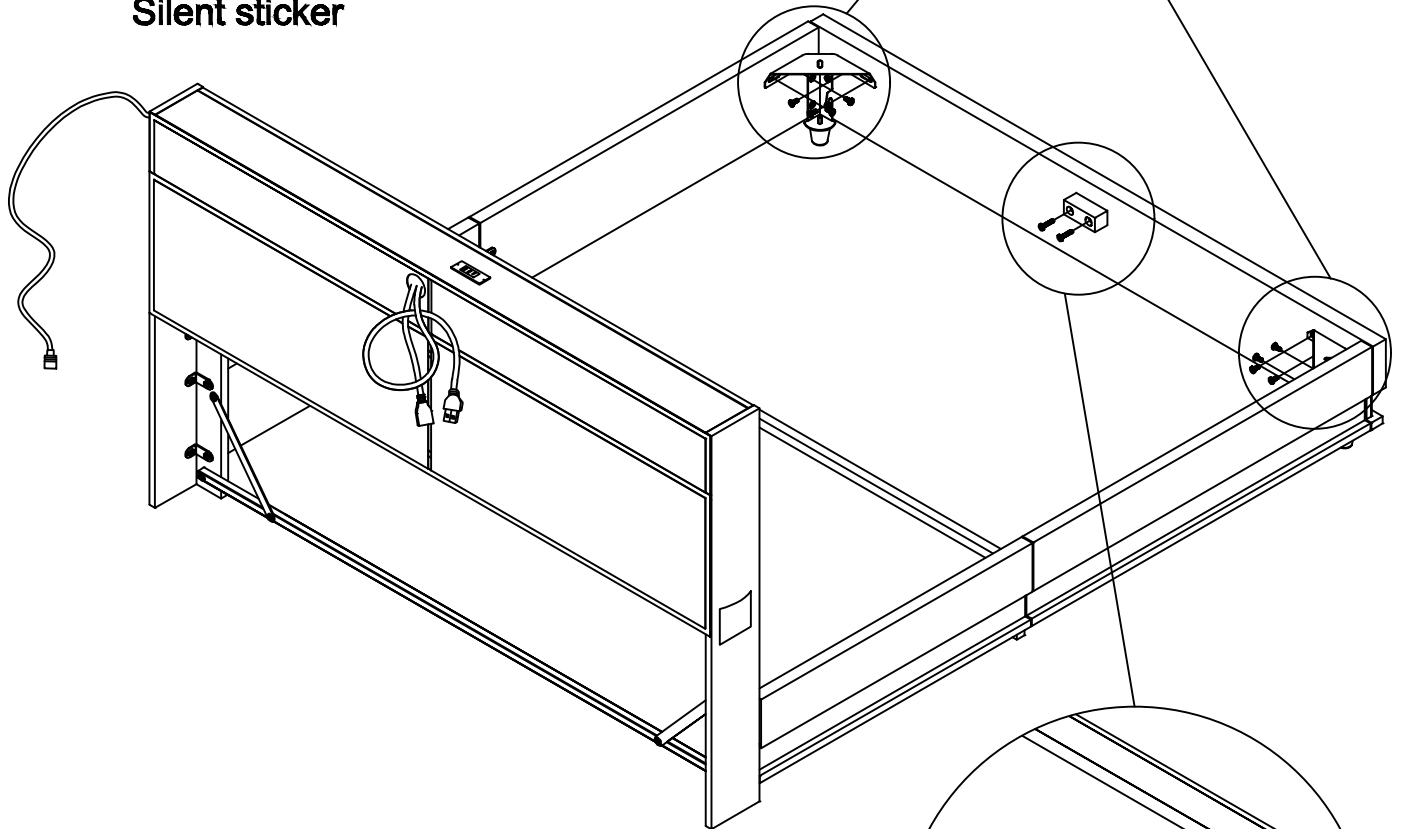
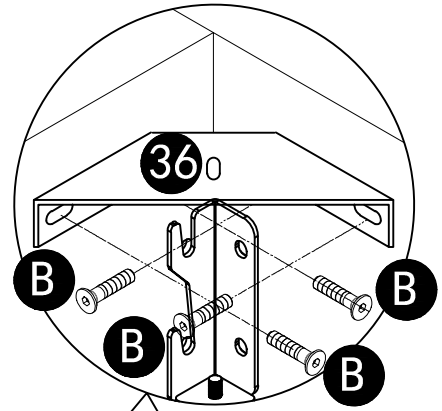
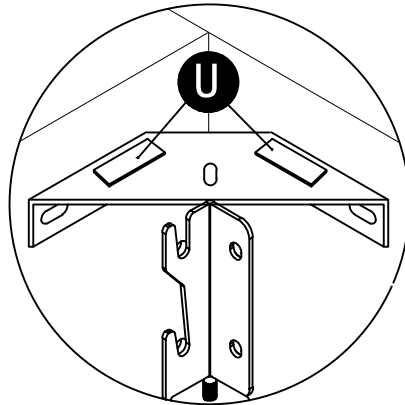
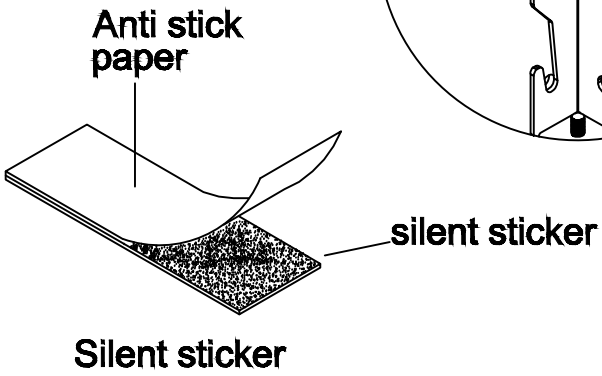

# 19

M8X35  
DX4pcs

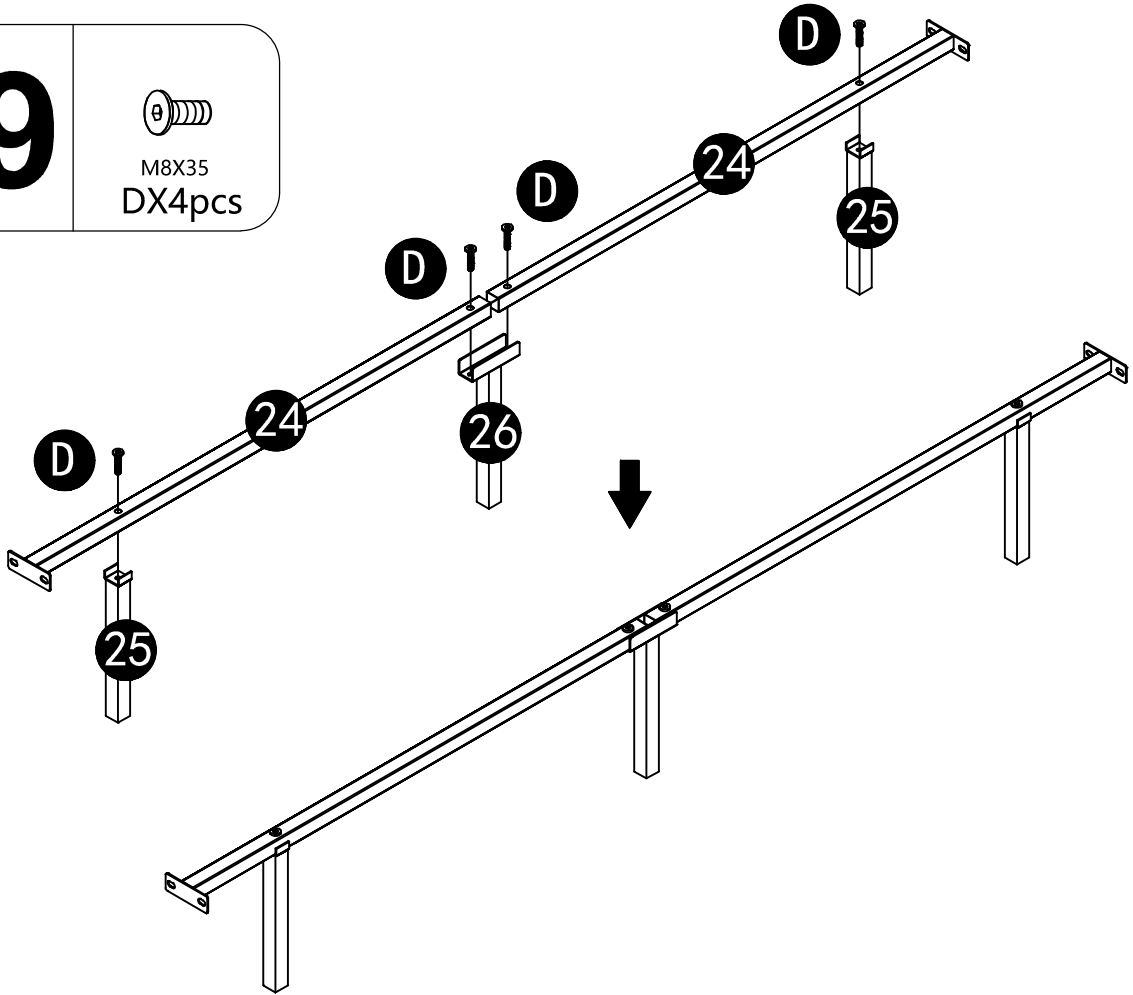

# 20

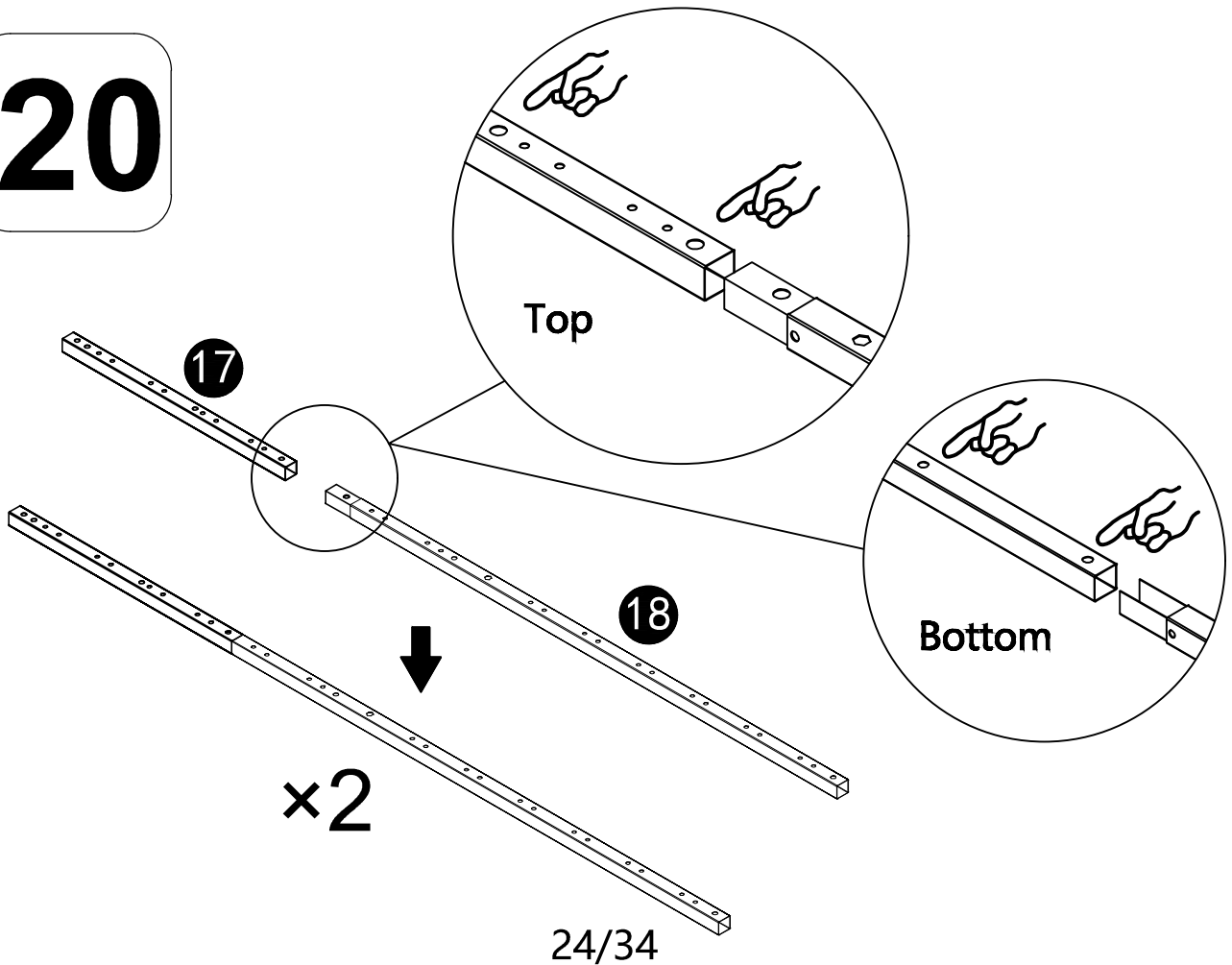

# 21



M8X12  
AX8pcs

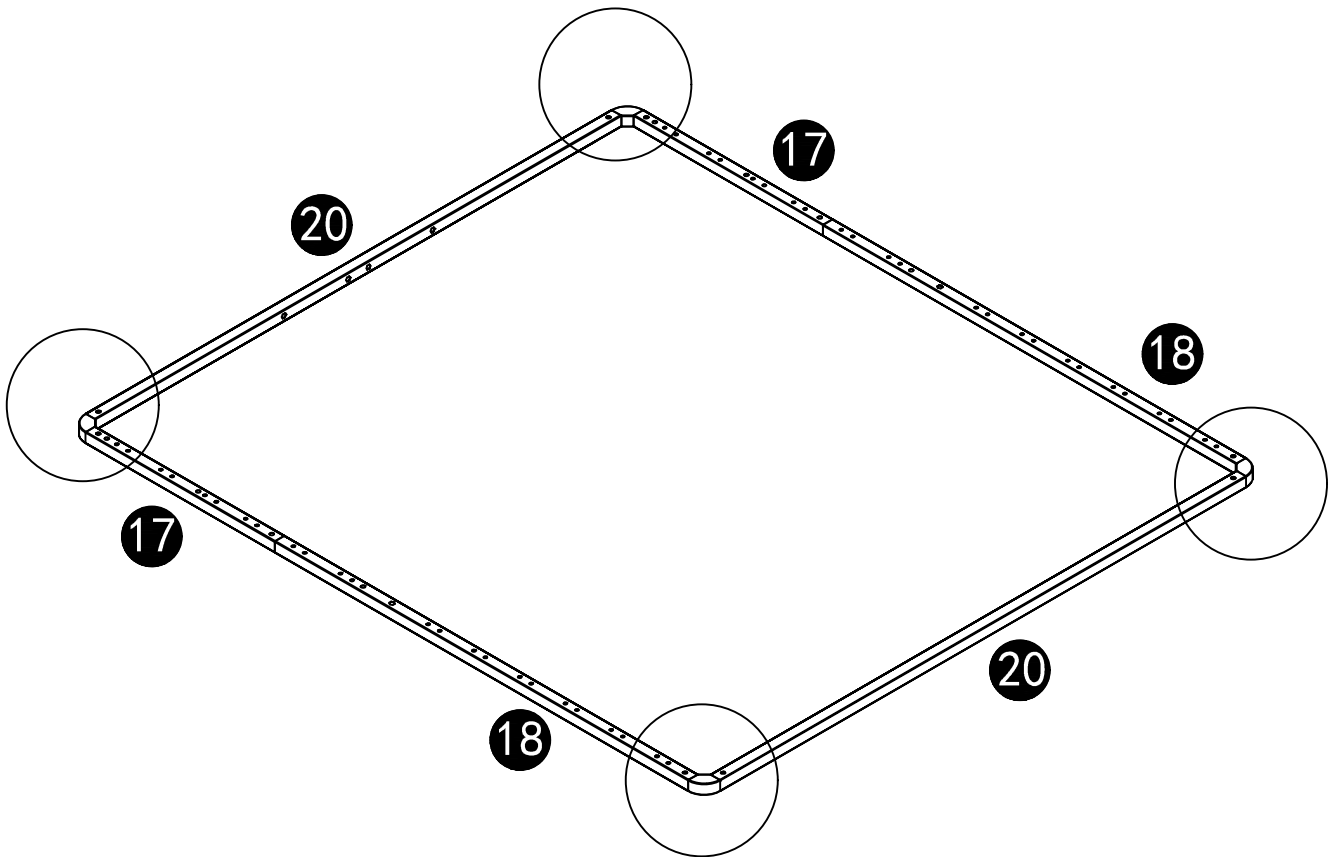
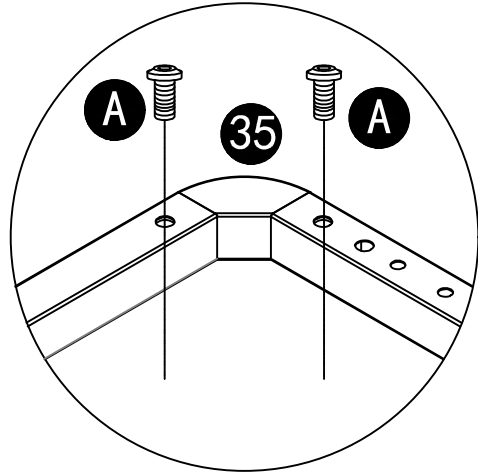
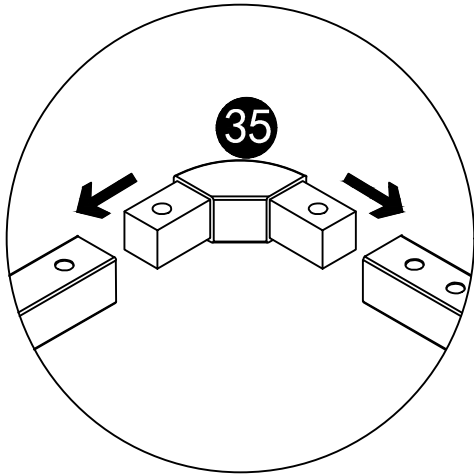

**22**



M8X20  
CX2pcs

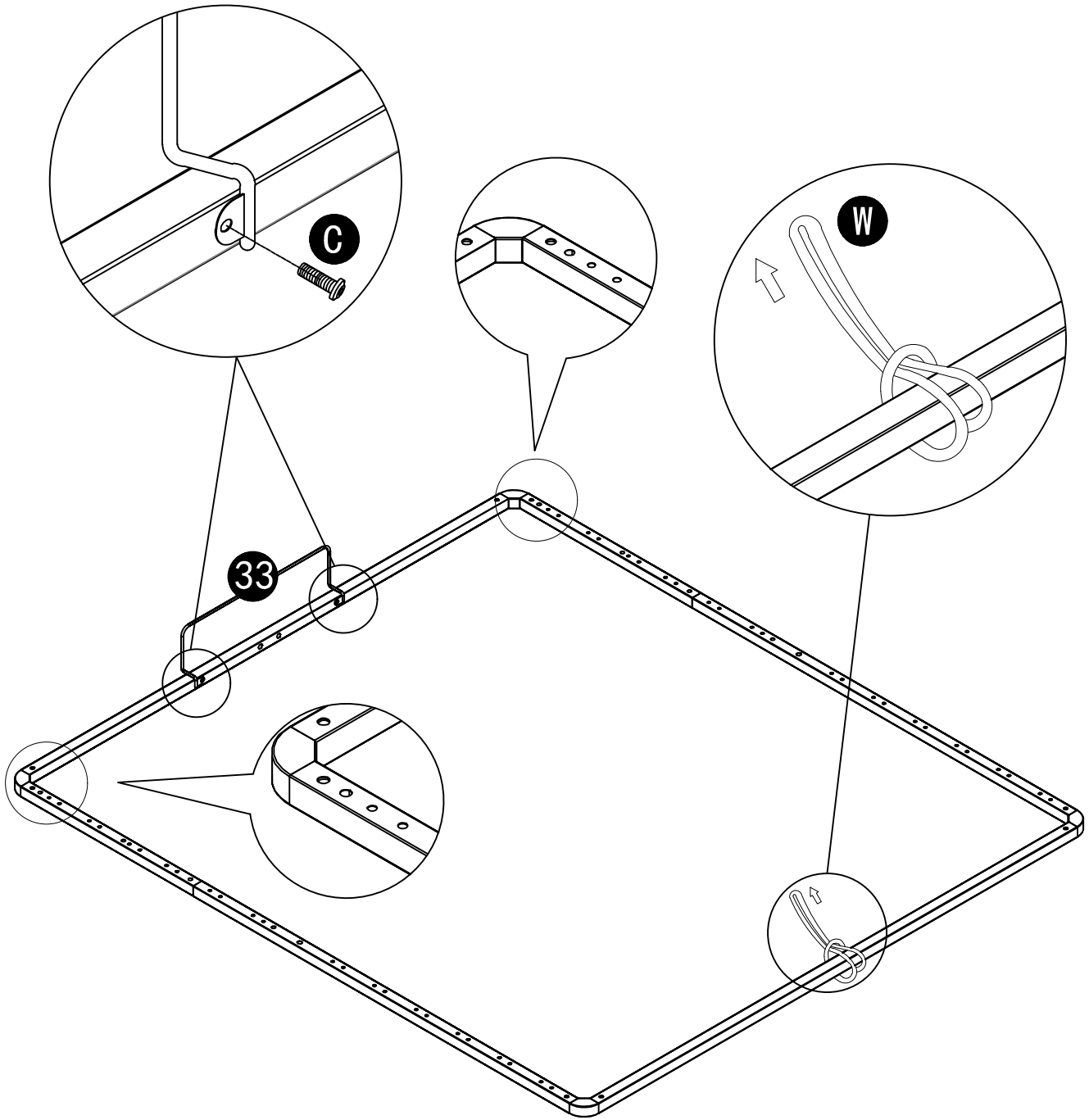

# 23

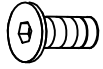

M8X50  
FX8pcs



M8  
JX8pcs

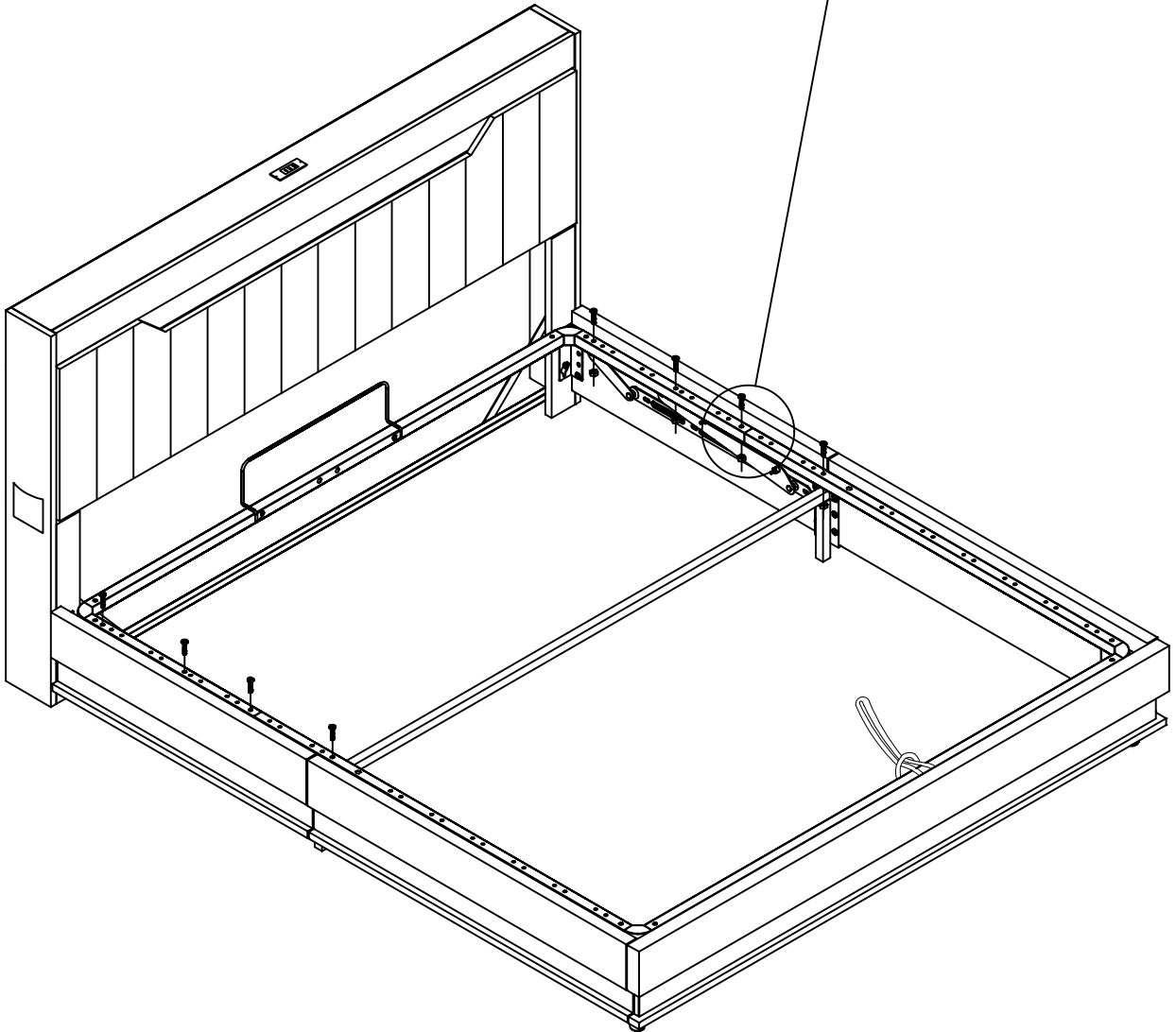
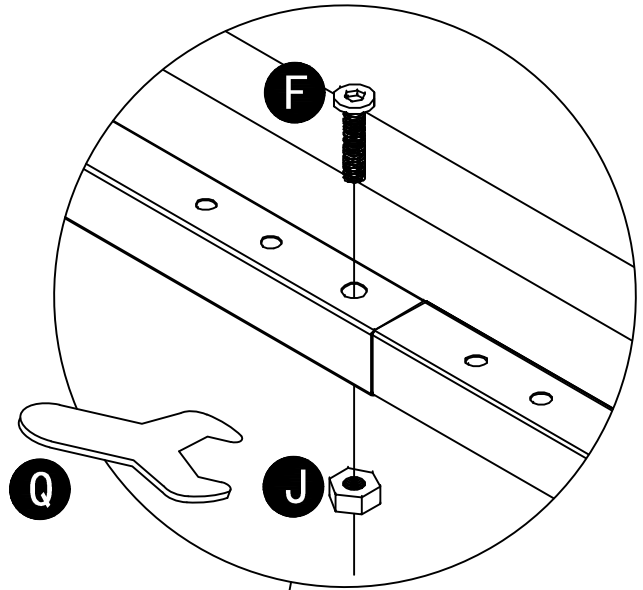

**24**



M8  
JX4pcs

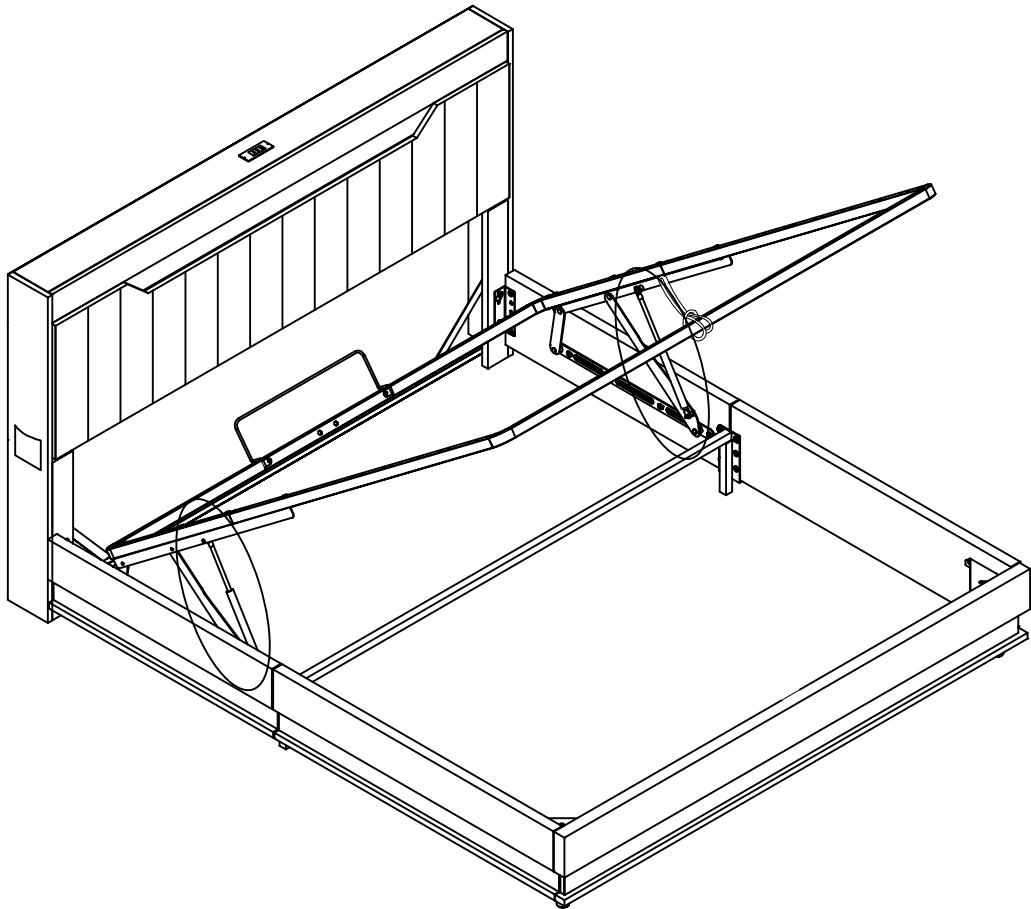
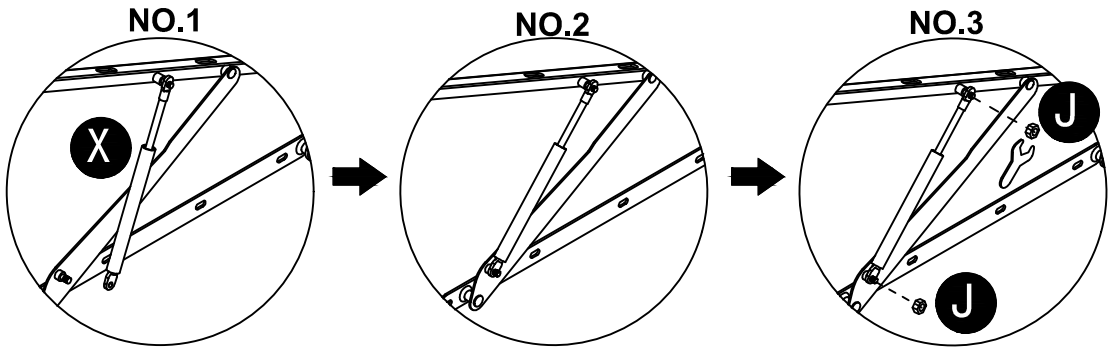

**25**



M8X20  
CX4pcs

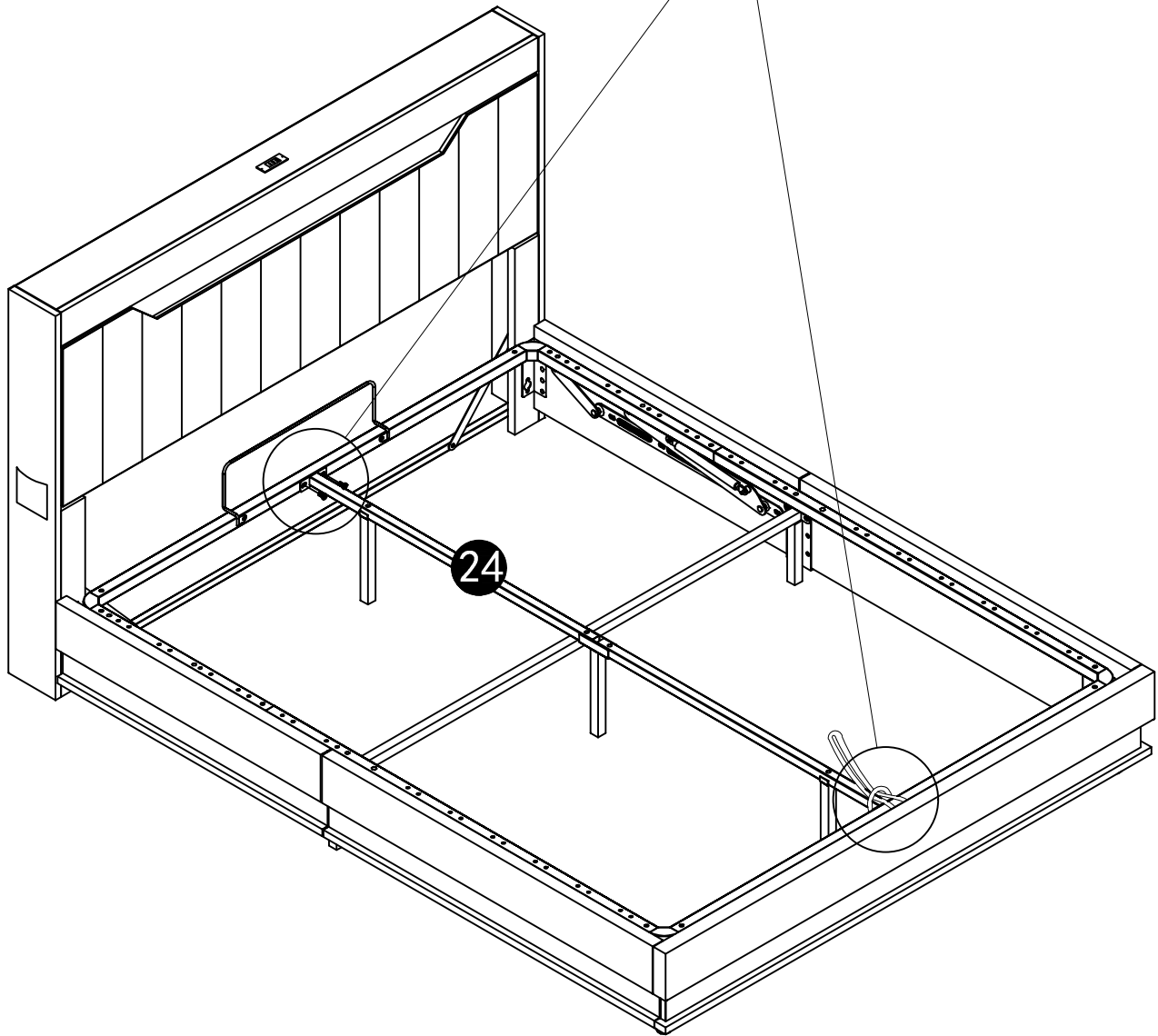
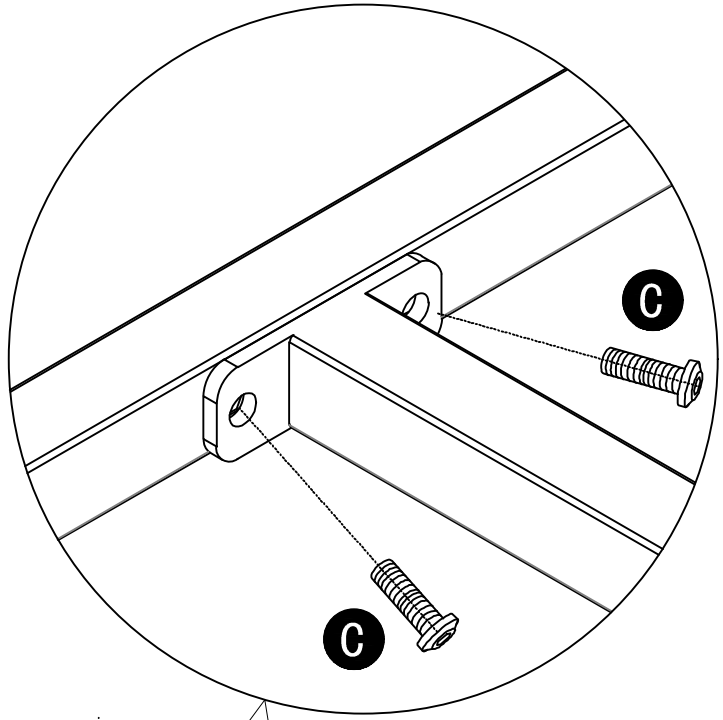

# 26

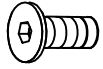

M8X50  
FX1pcs



M8X20  
CX2pcs

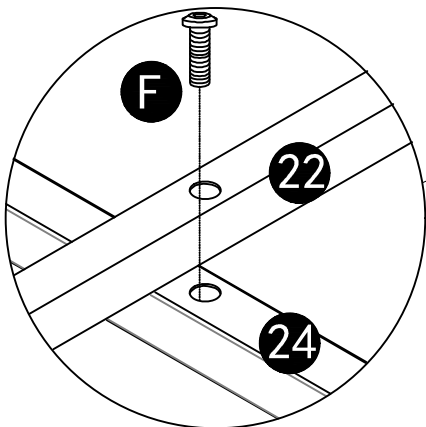
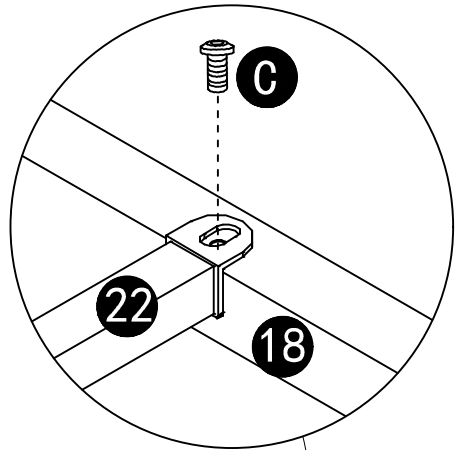
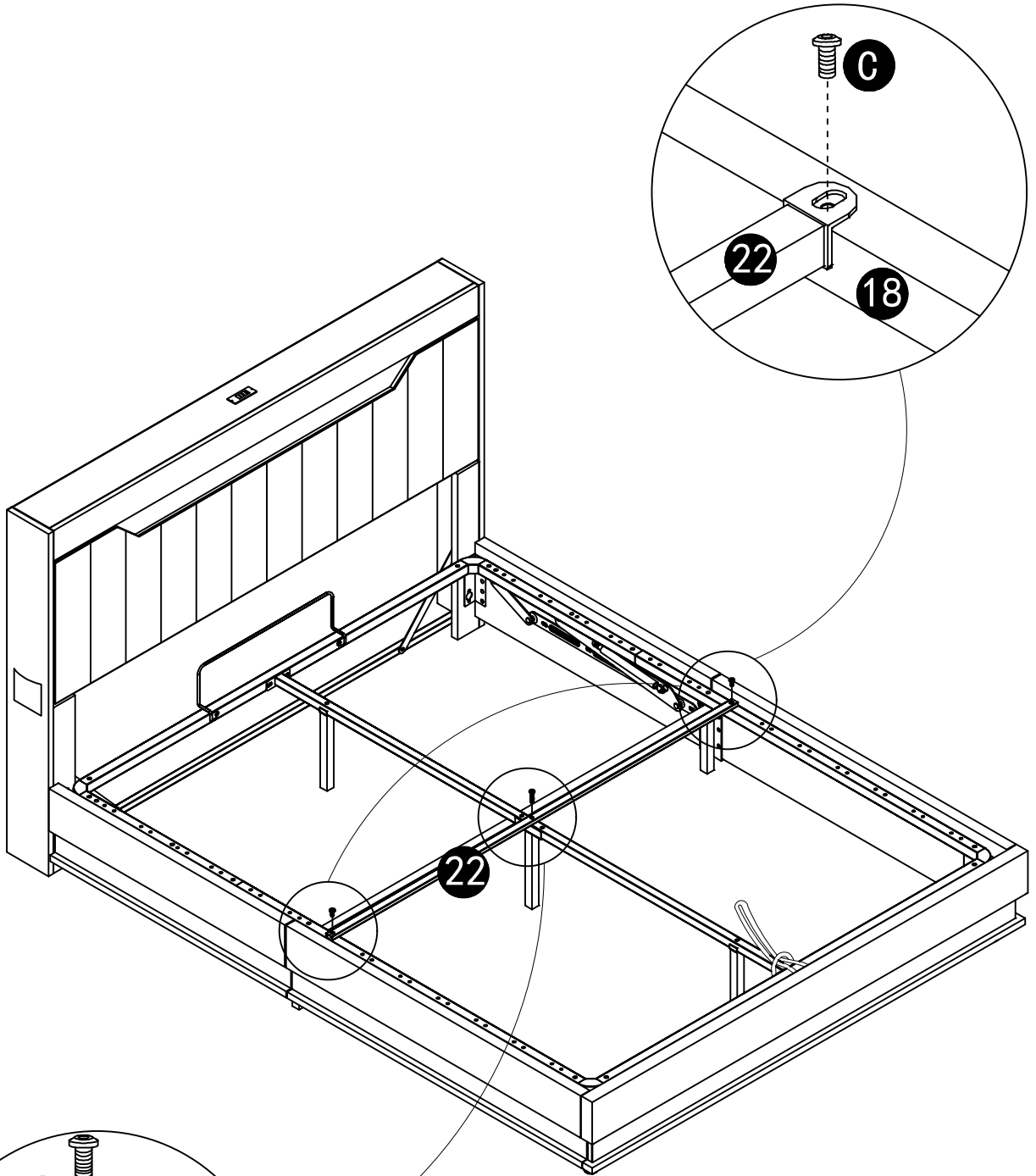

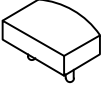
**27**   
PX24pcs

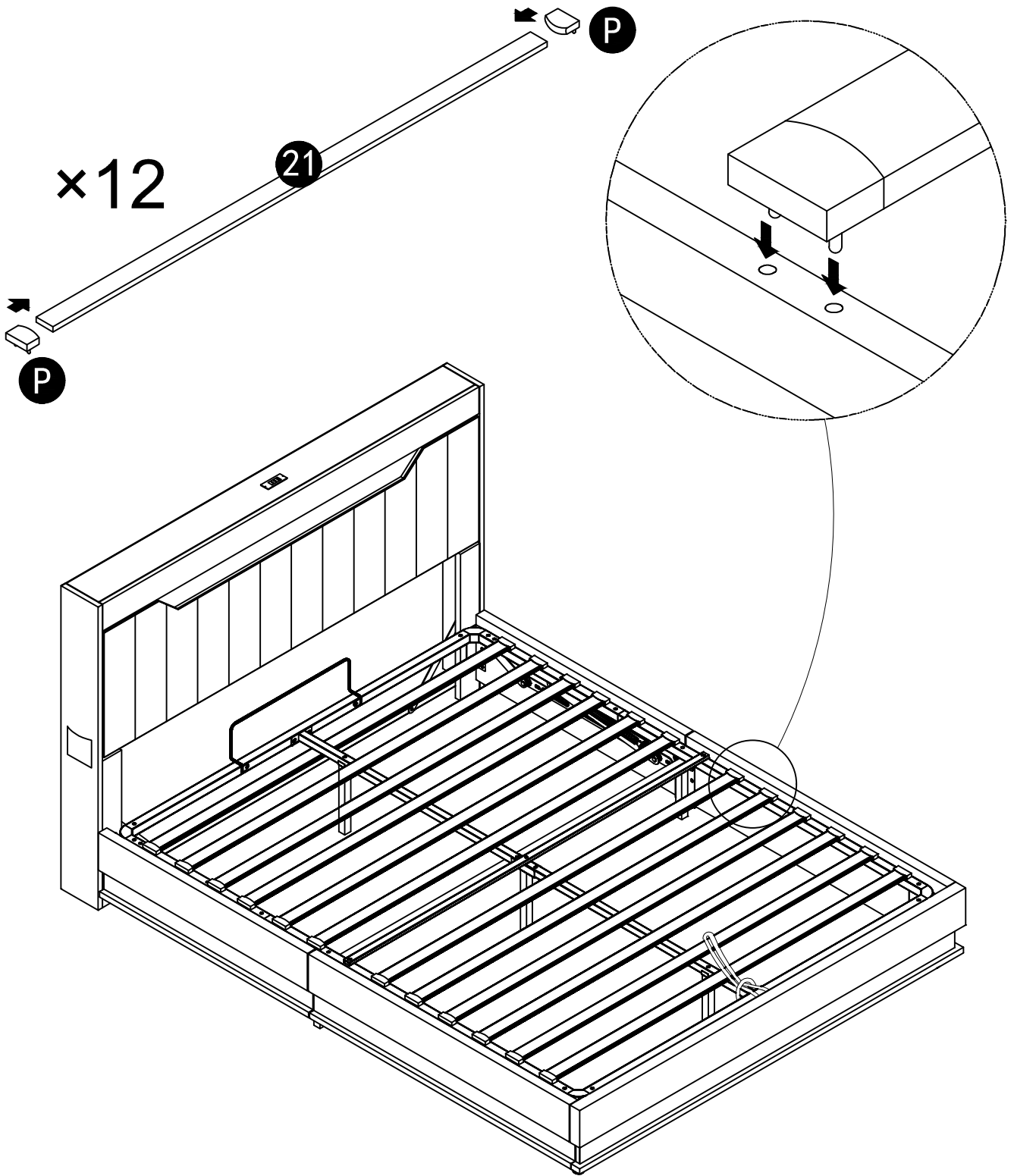

# 28

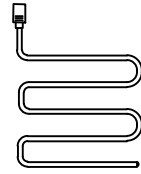
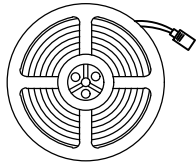

**Long light strip and unfold**  
**2PCS**

**Light strip**

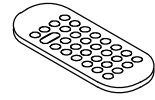

**Remote control**  
**1PC**



## WARNING

**AUSSERHALB DER REICHWEITE VON KINDERN AUFBEWAHREN**

Verschlucken kann zu Verätzungen, Weichteilperforationen und zum Tod führen. Schwere Verätzungen können innerhalb von zwei Stunden nach Einnahme auftreten. Suchen Sie sofort einen Arzt auf.



## AVERTISSEMENT

**TENIR HORS DE PORTÉE DES ENFANTS**

Avaler ce produit peut occasionner des brûlures chimiques, la perforation des tissus mous, voire la mort. Des brûlures graves peuvent survenir dans les 2 h suivant l'ingestion. Consulter immédiatement un médecin.

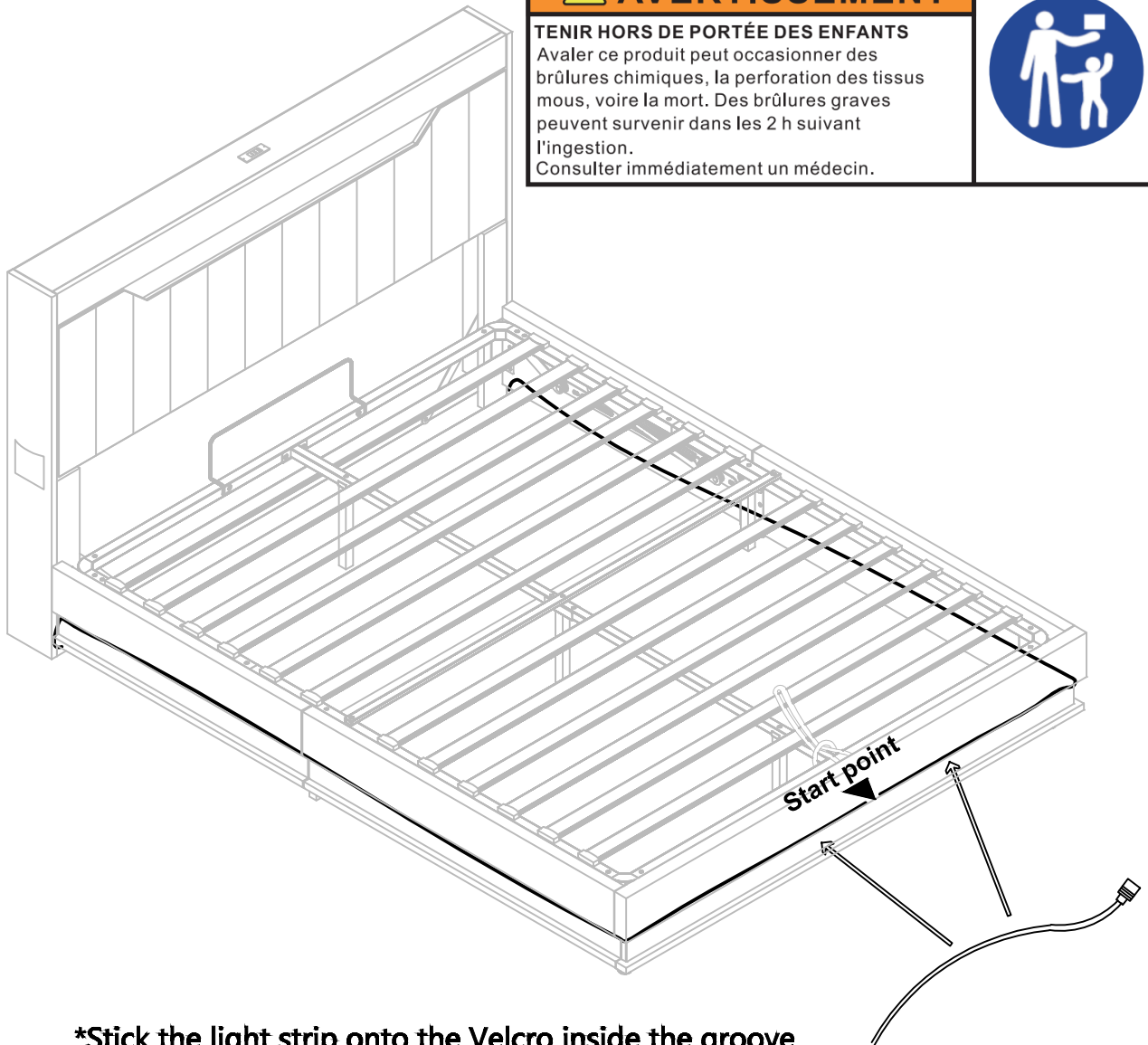

- \*Stick the light strip onto the Velcro inside the groove
- \*Kleben Sie den Lichtstreifen auf den Klettverschluss in der Nut
- \*Collez la bande lumineuse sur le velcro à l'intérieur de la rainure
- \*Pega la tira luminosa en el velcro dentro de la ranura
- \*Incollare la striscia luminosa sul velcro all'interno della scanalatura.

**29**

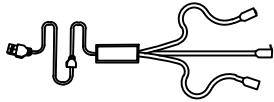

**S** Power cord  
1PC

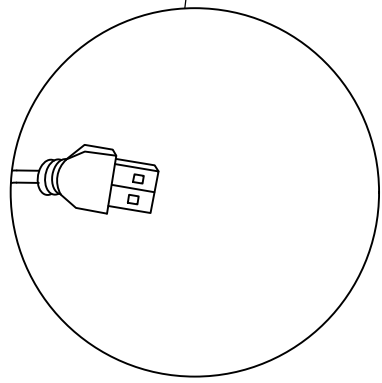
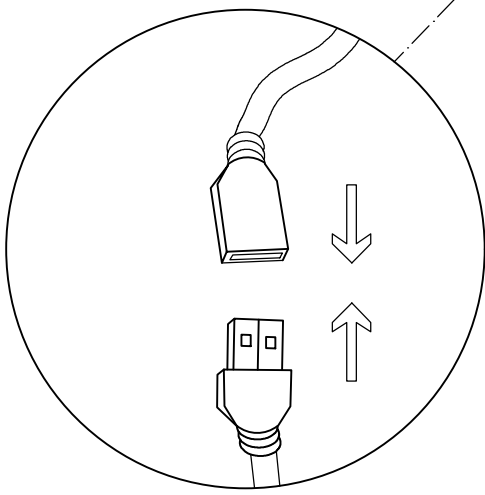
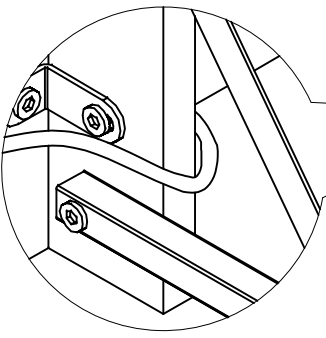
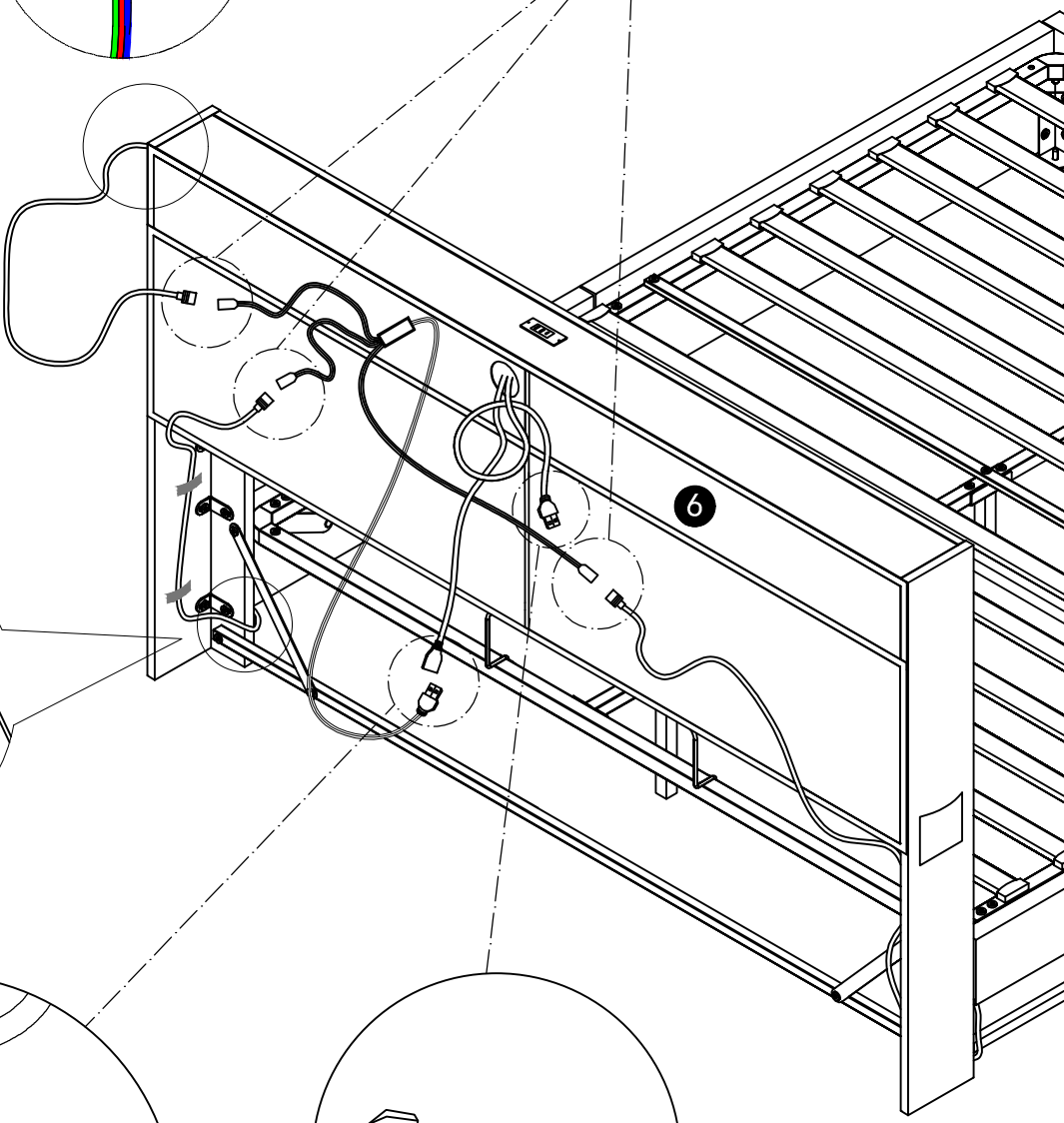
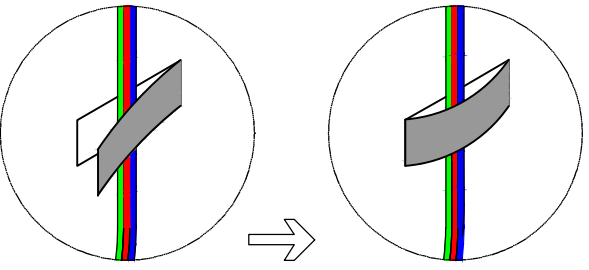
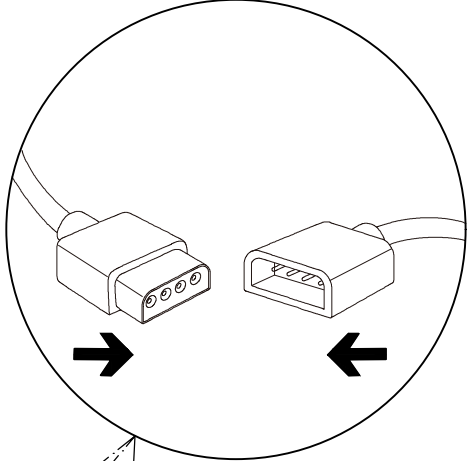

**The USB plug needs to be connected to a power source.**

**30**

Stick the Velcro of component 19 to the Velcro under the bed

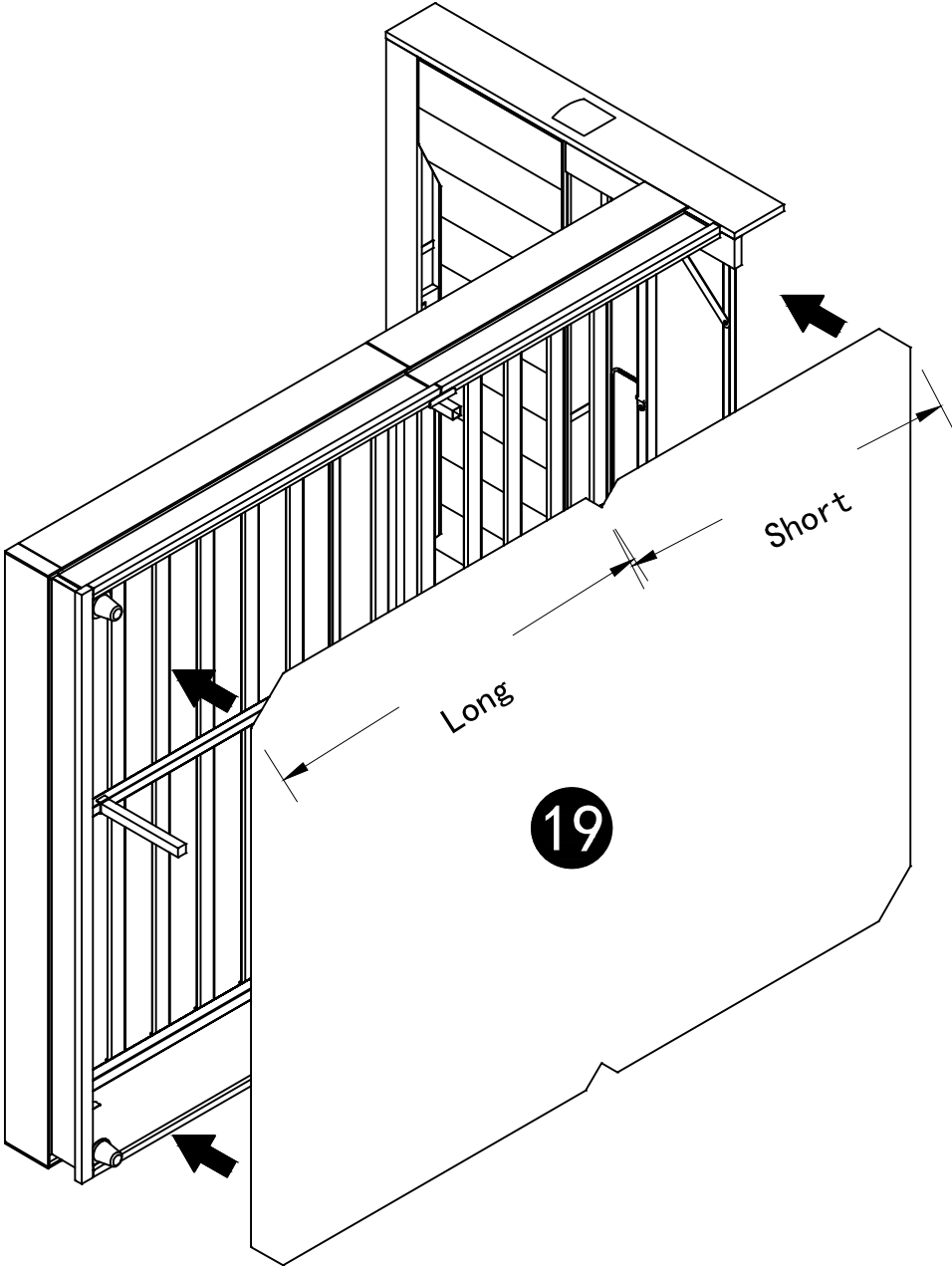

## EN:Battery Safety Instructions

1. Do not dispose of used button batteries or remote controls in household trash. To protect the environment and prevent hazardous leakage, please follow these guidelines:
2. Remove button batteries after use and take them to a local battery recycling point or hazardous waste collection site.
3. Do not burn or dismantle the batteries to avoid explosion or toxic release.
4. If the remote control is no longer in use, please deliver it to a certified electronics recycling facility to promote resource reuse.
5. Keep out of reach of children to prevent accidental ingestion or injury.
6. This product does not include batteries; please purchase them separately. The compatible button cell model for the remote control is CR2025, 3V.
7. If the light strip is not working, please try replacing the battery first. If the issue persists, contact the seller for assistance.
8. **Keep the remote control away from children — keep it away from children!** If the battery is accidentally swallowed, seek medical attention immediately.

## DE: Batteriesicherheitshinweise

1. Entsorgen Sie gebrauchte Knopfzellen oder Fernbedienungen nicht im Hausmüll. Um die Umwelt zu schützen und gefährliche Leckagen zu vermeiden, beachten Sie bitte die folgenden Hinweise:
2. Entfernen Sie die Knopfzelle nach dem Gebrauch und bringen Sie sie zu einer örtlichen Batteriesammelstelle oder einem Sondermüllentsorgungszentrum.
3. Batterien nicht verbrennen oder zerlegen, um Explosionen oder die Freisetzung giftiger Stoffe zu vermeiden.
4. Wenn die Fernbedienung nicht mehr verwendet wird, bringen Sie sie zu einer zertifizierten Elektronik-Recyclingstelle, um eine Wiederverwertung zu ermöglichen.
5. Außerhalb der Reichweite von Kindern aufbewahren, um versehentliches Verschlucken oder Verletzungen zu verhindern.
6. Dieses Produkt enthält keine Batterien. Bitte kaufen Sie diese separat. Das kompatible Knopfzellenmodell für die Fernbedienung ist CR2025, 3V.
7. Wenn der Lichtstreifen nicht funktioniert, versuchen Sie zunächst, die Batterie zu wechseln. Besteht das Problem weiterhin, kontaktieren Sie bitte den Verkäufer.
8. **Halten Sie die Fernbedienung unbedingt von Kindern fern — unbedingt fernhalten!** Wird die Batterie versehentlich verschluckt, suchen Sie sofort medizinische Hilfe auf.

## FR:Instructions de sécurité pour les piles

1. Ne jetez pas les piles bouton usagées ou les télécommandes à la poubelle ménagère. Pour protéger l' environnement et éviter tout risque de fuite dangereuse, veuillez suivre les consignes suivantes :
  2. Retirez les piles bouton après usage et déposez-les dans un point de collecte local ou un centre de déchets dangereux.
  3. Ne brûlez pas et ne démontez pas les piles, cela pourrait entraîner une explosion ou libérer des substances toxiques.
  4. Si la télécommande n'est plus utilisée, déposez-la dans un centre de recyclage agréé pour appareils électroniques, afin de favoriser la réutilisation des ressources.
  5. Gardez hors de portée des enfants pour éviter tout risque d'ingestion accidentelle ou de blessure.
- 6.Ce produit ne contient pas de pile. Veuillez l'acheter séparément. Le modèle de pile bouton compatible pour la télécommande est CR2025,3V.
- 7.Si le ruban LED ne fonctionne pas, essayez d'abord de remplacer la pile. Si le problème persiste, contactez le vendeur.
- 8.**Tenez la télécommande éloignée des enfants — éloignez-la vraiment !** En cas d'ingestion accidentelle de la pile, consultez immédiatement un médecin.

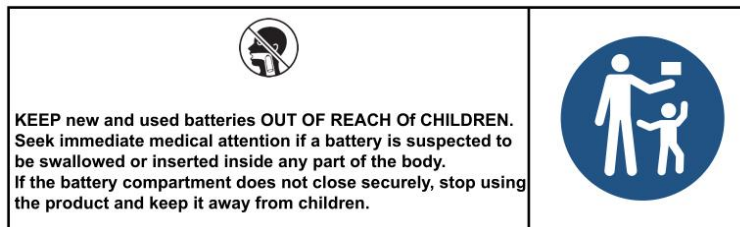

If a battery has been ingested, or there is a possibility one might have been ingested, please seek medical attention and inform the medical authorities that you suspect battery ingestion.

It's not always clear when a child has swallowed a button battery, as there are no specific symptoms. However, they might:

- cough, gag, or drool;
- seem to have a stomach bug or virus;
- vomit;
- complain of pain in their stomach, chest, or throat;
- appear tired or sluggish; and
- lose their appetite.

Since the signs aren't obvious, it's important to keep a close eye on loose, used, or spare button batteries in your home, as well as the products that contain them.

**NOTE:**The battery in the remote control requires you to purchase and install it yourself.  
**Model:CR2025 3.V**



Reference No. : WTN23N07163435E  
Applicant : Guangdong Zhangong Electrical Technology Co., LTD  
Address : 701, Building 29, Zhifu Garden, Xingtan Town, Shunde District, Foshan City  
Manufacturer : Same as applicant  
Address : Same as applicant  
Product : Furniture Power Distribution Units  
Model No. : ZG-JJY-1UK to -8UK, others see attachment  
Technical data : 250 Vac, 50 - 60 Hz, 13 A, USB: 5 Vdc, 2 A

#### Test Standards:

BS EN IEC 55015:2019+A11:2020  
BS EN 61547:2009  
BS EN IEC 61000-3-2:2019+A1:2021  
BS EN 61000-3-3:2013+A1:2019+A2:2021

The above product has been tested by us with the listed standards and found in compliance with the Electromagnetic Compatibility Regulations 2016 of United Kingdom (S.I. 2016 No.1091). It is possible to use UKCA marking to demonstrate the compliance with the regulations.

**BS EN IEC 55015: Limits and methods of measurement of radio disturbance characteristics of electrical lighting and similar equipment**  
**BS EN 61547: Equipment for general lighting purposes — EMC immunity requirements**  
**BS EN IEC 61000-3-2: Electromagnetic compatibility (EMC) Part 3-2: Limits — Limits for harmonic current emissions (equipment input current  $\leq 16$  A per phase)**  
**BS EN 61000-3-3: Electromagnetic compatibility (EMC) Part 3-3: Limits - Limitation of voltage changes, voltage fluctuations and flicker in public low-voltage supply systems, for equipment with rated current  $\leq 16$  A per phase and not subject to conditional connection**

The referred test report(s) show that the product complies with standard(s) recognized as giving presumption of compliance with the essential requirements in the above mentioned UK regulations. Other relevant UK regulations have to be observed.

After preparation of the necessary technical documentation as well as the declaration of conformity, the UKCA marking as shown below can be affixed on the equipment under the sole responsibility of the manufacturer.

**UK  
CA**

  
Manager: Jianzhong Mao  
Date: 2023-09-05

The statement is based on a single evaluation of the sample of above mentioned product. It does not imply an assessment of the whole production.

**Waltek Testing Group (Ningbo) Co., Ltd.**

Hotline: 400-840-2288 E-mail: nb@waltek.com.cn  
Http://www.waltek.com.cn

Ver.10.22, WALTEK is registered trademark. Utilisation and application requires prior approval.

# Attachment

## Model list



Reference No.: WTN23N07163435E

No.	Model	Rated Input	Max Current	Max Output	Note
1.	ZG-JJY-1	250 Vac, 50 - 60 Hz	13 A	USB: 5 Vdc, 2 A	/
2.	ZG-JJY-1UK	250 Vac, 50 - 60 Hz	13 A	USB: 5 Vdc, 2 A	/
3.	ZG-JJY-2	250 Vac, 50 - 60 Hz	13 A	USB: 5 Vdc, 2 A	/
4.	ZG-JJY-2UK	250 Vac, 50 - 60 Hz	13 A	USB: 5 Vdc, 2 A	/
5.	ZG-JJY-3	250 Vac, 50 - 60 Hz	13 A	USB: 5 Vdc, 2 A	/
6.	ZG-JJY-3UK	250 Vac, 50 - 60 Hz	13 A	USB: 5 Vdc, 2 A	/
7.	ZG-JJY-4	250 Vac, 50 - 60 Hz	13 A	USB: 5 Vdc, 2 A	/
8.	ZG-JJY-4UK	250 Vac, 50 - 60 Hz	13 A	USB: 5 Vdc, 2 A	/
9.	ZG-JJY-5	250 Vac, 50 - 60 Hz	13 A	USB: 5 Vdc, 2 A	/
10.	ZG-JJY-5UK	250 Vac, 50 - 60 Hz	13 A	USB: 5 Vdc, 2 A	/
11.	ZG-JJY-6	250 Vac, 50 - 60 Hz	13 A	USB: 5 Vdc, 2 A	/
12.	ZG-JJY-6UK	250 Vac, 50 - 60 Hz	13 A	USB: 5 Vdc, 2 A	/
13.	ZG-JJY-7	250 Vac, 50 - 60 Hz	13 A	USB: 5 Vdc, 2 A	/
14.	ZG-JJY-7UK	250 Vac, 50 - 60 Hz	13 A	USB: 5 Vdc, 2 A	/
15.	ZG-JJY-8	250 Vac, 50 - 60 Hz	13 A	USB: 5 Vdc, 2 A	/
16.	ZG-JJY-8UK	250 Vac, 50 - 60 Hz	13 A	USB: 5 Vdc, 2 A	/





## VERIFICATION OF CONFORMITY

**No.** : PTC25082917901E-RF02  
**Applicant** : Dongguan Yihong Hardware electronics Co., LTD  
**Address** : Room 1106,NO.2 Shangheng Road,Chang'an Town  
 Dongguan,Guangdong,523880 China  
**Manufacturer** : Dongguan Yihong Hardware electronics Co., LTD  
**Address** : Room 1106,NO.2 Shangheng Road,Chang'an Town  
 Dongguan,Guangdong,523880 China  
**Product** : 2.4G Remote Controller  
**Trade Mark** : -  
**Model** : YH-629, YH-6181, YH-6183, YH-358  
**Ratings** : DC 3V

The submitted sample of the above equipment has been tested and found to comply with the following UK legislation:

**S.I. 2017 No. 1206 Radio Equipment Regulations 2017**

The standard(s) used for showing compliance with the essential requirements:

Applicable Standard(s)	Test Report(s) Number
ETSI EN 300 440 V2.2.1 (2018-07)	PTC25082917901E-EM01
ETSI EN 301 489-1 V2.2.3 (2019-11)	PTC25082917901E-EM02
ETSI EN 301 489-3 V2.3.2 (2023-01)	
BS EN 62479:2010	PTC25082917901E-EM03
BS EN IEC 62368-1:2020+A11:2020	PTC25082917901S-LD01

This verification is part of the full test report(s) and should be read in conjunction with it. This verification is based on an evaluation of one sample of above mentioned product. It does not imply assessment of the production of the product. Without the written approval of Precise Testing & Certification (Guangdong) Co., Ltd. this verification is not permitted to be reproduced, except in full. It is not permitted to use the test lab's logo. The UKCA marking may only be used if all the relevant and effective UK legislation are applicable.



*Jacky Ou*  
 Jacky Ou  
 Manager  
 Date: 2025-09-23



Shenzhen ZKT Technology Co., Ltd.  
 1/F, No. 101, Building B, No. 6, Tangwei Community Industrial Avenue,  
 Fuhai Street, Bao'an District, Shenzhen, China



# Certificate of Compliance

**Certificate Number: ZKT-25070215184C**

**Certificate's Holder** : Dongguan Yihong Hardware Electronics Co., Ltd  
 Room 1106, No.2, Shangheng Road, Chang' an Town,  
 Dongguan

**Manufacturer** : Dongguan Yihong Hardware Electronics Co., Ltd  
 Room 1106, No.2, Shangheng Road, Chang' an Town,  
 Dongguan

**Trade Mark** : N/A

**Product** : LED controller

**Model(s)** : YH-6183  
 YH-252, YH-284, YH-290, YH-287, YH-358, YH-360, YH-6180,  
 YH-6184

Requirement	Standard	Report No.
Art.3.1(a) Safety	BS EN IEC 62368-1:2024+A11:2024	ZKT-25070215185S
Art.3.1(a) Health	BS EN IEC 62311:2020 BS EN 50665:2017	ZKT-25070215184E-1
Art.3.1(b) EMC	ETSI EN 301 489-1 V2.2.3 (2019-11) ETSI EN 301 489-17 V3.3.0 (2024-07)	ZKT-25070215184E-2
Art.3.2 Radio	ETSI EN 300 328 V2.2.2 (2019-07)	ZKT-25070215184E-3

This Attestation of Compliance is issued on a voluntary basis for electrical equipment below the voltage limits of Radio Equipment Directive (RED) 2014/53/EU. The essential requirement are fulfilled accordingly based on the technical specifications applicable at the time of issuance.



This Certificate of Conformity is based on single evaluation of the submitted sample(s) of the above mentioned product. It does not imply an assessment of the whole product and relevant Directives to be observed.

# Attestation of Compliance

Declaration No.:	MK23110141P01-E01
Name and address of Applicant:	<b>Shenzhen Hongzhengyu Technology Co., LTD</b> Shenzhen baoan district rock street industrial science and technology industrial park of 2 Haitian lanyu 3 5 floor of A
Name and address of Manufacturer:	<b>Shenzhen Hongzhengyu Technology Co. LTD</b> Shenzhen baoan district rock street industrial science and technology industrial park of 2 Haitian lanyu 3 5 floor of A
Product name:	<b>RGB package</b>
Rated:	DC5V
Product model(s):	HZY-5050RGB-30D-90R-DC5V, HZY-5050RGB-30D-30R-DC5V, HZY-5050RGB-60D-60R-DC5V, HZY-5050RGB-60D-180R-DC5V, HZY-5050RGB-18D-18R-DC5V
Product trademark:	N/A

This Attestation of Compliance confirms that the product meets the requirements of the following standard.

BS EN IEC 55015:2019+A11:2020  
 IEC 61547:2020  
 BS EN IEC 61000-3-2:2019  
 BS EN 61000-3-3:2013/A2:2021

*The Attestation of Compliance has been carried out in accordance with individual rules and conditions agreed with the applicant. Evaluation has been carried out in accordance with:*

Test report(s) No.:	MK23110141P01-E01
Test conducted by:	TMC Testing Services (Shenzhen) Co., Ltd.
Declaration issue date:	December 5, 2023

#### Notes:

*This Attestation of Compliance is issued according to the Great Britain legislation Electromagnetic Compatibility Regulations 2016( SI 2016 No. 1091). It confirms that the listed products complies with all essential requirements of the Regulations and applies only to the sample and its technical documentation to TMC Testing Services (Shenzhen) Co., Ltd. for testing.*

*After preparation of the necessary technical documentation (which must be kept for up 10 years after the product is placed on the GB market) as well as the UK Declaration of Conformity, the required UKCA marking can be affixed on the product. Other relevant Regulations have to be observed.*

#### TMC Testing Services (Shenzhen) Co. Ltd.

t:86-755-86642861 cert@tmc-lab.com www.tmc-lab.com

1st Floor, Block A1, Zone A, Xinshidai Gongrong Industrial Park, No. 2, Shihuan Road, Shiyuan Street, Baoan District, Shenzhen, China



*Vivian Jiang*  
 Lab Director  
 Vivian Jiang

# UK CA

UK  
CA



Importer	COMHARBOR LIMITED		
Add	Unit C,Swit Point,Cosford Lane,Rugby,CV211PY,GB		
Email/URL	harborcomhar@gmail.com		
Manufacturer	Dongguan Yihong Hardware Electronics Co.. Ltd		
Add	Room 1106.No.2,Shangheng Road, Chang an Town		
Email/URL	<a href="mailto:414564409@qq.com">414564409@qq.com</a>		
Product identification	202509		
Made in	China		
Produt Name: LED Controller Model:YH-284			
Rated voltage: 5 V Rated frequency:50/60Hz Power:15W			
<table border="1"><tr><td>UK</td><td>REP</td></tr></table>	UK	REP	COMHARBOR LIMITED Unit C,Swit Point,Cosford Lane,Rugby,CV211PY,GB harborcomhar@gmail.com
UK	REP		

UK  
CA



Importer	COMHARBOR LIMITED		
Add	Unit C,Swit Point,Cosford Lane,Rugby,CV211PY,GB		
Email/URL	harborcomhar@gmail.com		
Manufacturer	<b>Shenzhen HongzhengYu Technology Co., LTD</b>		
Add	Shenzhen baoan dist ict rock street industrial science and technology industrial Park of 2 Haitian lanYu 3 5 floor of A		
Email/URL	<a href="mailto:610488898@qq.com">610488898@qq.com</a>		
Product identification	202509		
Made in	China		
Produt Name: LED soft light strip Model:HZY-5050RGB-30D-30R-DC5V			
Rated voltage: 5 V Rated frequency:50/60Hz Power:4.5W/M			
<table border="1"><tr><td>UK</td><td>REP</td></tr></table>	UK	REP	COMHARBOR LIMITED Unit C,Swit Point,Cosford Lane,Rugby,CV211PY,GB harborcomhar@gmail.com
UK	REP		

**UK  
CA**



Importer	COMHARBOR LIMITED		
Add	Unit C,Swit Point,Cosford Lane,Rugby,CV211PY,GB		
Email/URL	harborcomhar@gmail.com		
Manufacturer	Dongguan Yihong Hardware Electronics Co.. Ltd		
Add	Room 1106.No.2,Shangheng Road, Chang an Town		
Email/URL	<a href="mailto:414564409@qq.com">414564409@qq.com</a>		
Product identification	202509		
Made in	China		
Produit Name: 2.4GRemoteController			
Rated Voltage: 3V Power: 0.0006W			
<table border="1"><tr><td><b>UK</b></td><td><b>REP</b></td></tr></table>	<b>UK</b>	<b>REP</b>	COMHARBOR LIMITED Unit C,Swit Point,Cosford Lane,Rugby,CV211PY,GB harborcomhar@gmail.com
<b>UK</b>	<b>REP</b>		

**UK  
CA**



Importer	COMHARBOR LIMITED		
Add	Unit C,Swit Point,Cosford Lane,Rugby,CV211PY,GB		
Email/URL	harborcomhar@gmail.com		
Manufacturer	Guangdong Zhangong Electrical Technology Co., LTD		
Add	701, Building 29, Zhifu Garden, Xingtan Town, Shunde District, Foshan City		
Email/URL	<a href="mailto:info@waltek.com">info@waltek.com</a>		
Product identification	202509		
Made in	China		
Produit Name: Furniture Power Distrbution Units			
Input AC:220-250V 50/60HZ 10-13A Out Put: DC 5V. 2A			
<table border="1"><tr><td><b>UK</b></td><td><b>REP</b></td></tr></table>	<b>UK</b>	<b>REP</b>	COMHARBOR LIMITED Unit C,Swit Point,Cosford Lane,Rugby,CV211PY,GB harborcomhar@gmail.com
<b>UK</b>	<b>REP</b>		