

ASSEMBLY INSTRUCTIONS

- A. Find a clear area in which to work and carefully unpack the fixture from the carton.
- B. Read through all instruction sheets provided prior to starting assembly.

Fixture assembly:

During assembly please reference page 2 for parts indentification.

1. Slip center rod (2) along wire and thread it into coupler (D).
2. Slip scroll assembly (3) onto center stem (2).
3. Slip cup (4) folowed by washer (5) and spacer (6).
4. Slid loop (7) along wire and thread onto end of center stem (2). DO NOT tighten loop.
5. Using the Armspread drawing below as reference gently position arms in the following order.
 - A. The small top tier A arms are to be equally spaced 120 degrees apart.
 - B. The middle tier arms (B) are to be equally spaced 60 degrees apart. Making sure the top tier (A) are equally spaced between every other (B) arm.
 - C. The bottom tier large arms (C) are to be equally spaced 60 degrees apart, between the middle tier arms (B).
 Arms are now in there correct position.
6. Take the uprights (8) and attach one end to the top of the lower arm scroll (E), using the ball knob screws (9) provided.
7. Adjust the top scroll assembly (3) so the arms (F) line up with the uprights (8), tighten loop to secure in position.
8. Attach the top of the uprights (8) to the scroll assembly arms (F), using ball knob screws (9) provided.

Fixture is ready for installation. Please follow all mounting instructions provided.

* Turn off power supply during installation

* If new wiring is required, consult a qualified electrician or local authorities for code requirements.

Glass installation:

1. Remove socket ring (10) from socket (G).
2. Slip glass (11) over socket.
3. Thread socket ring (10) back onto socket (G) and tighten. Caution: hand tighten only! overtightening using a tool, could cause glass damage.

NOTE: Maximum wattage per bulb is 40 watts.

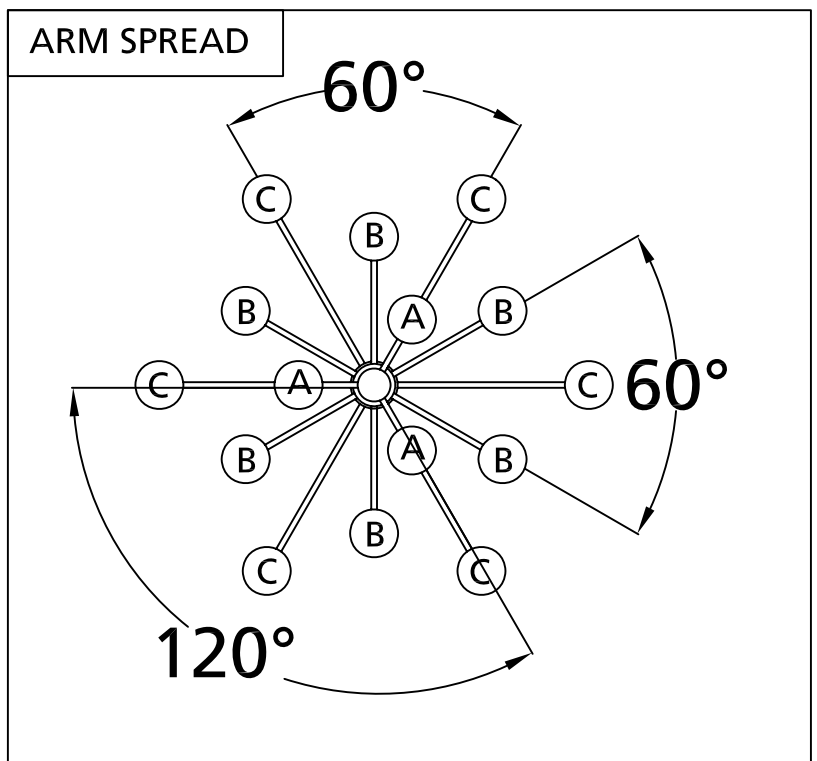

ASSEMBLY INSTRUCTIONS

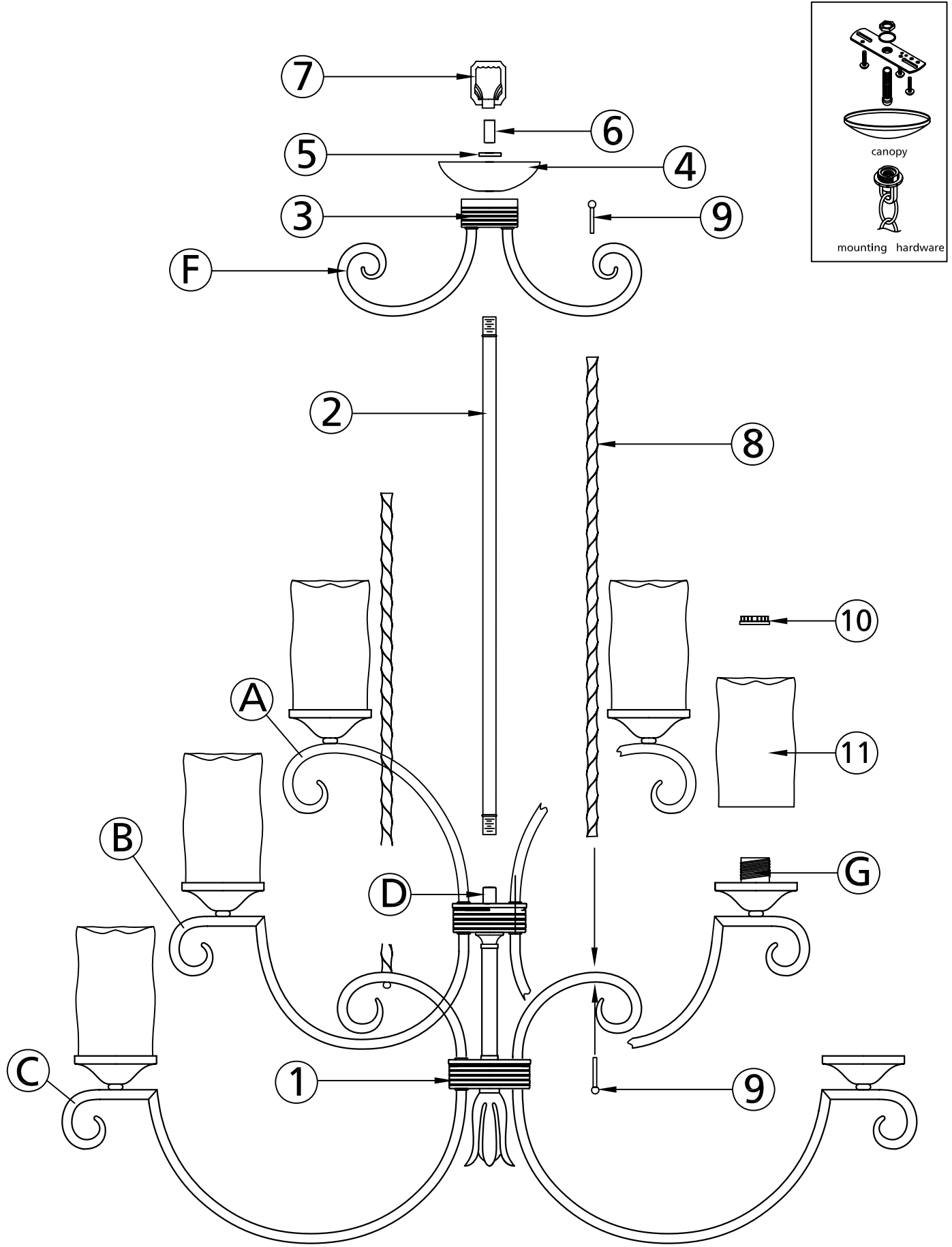

hanging instructions

▼ start here

Drawing 1 - Hanging Assembly

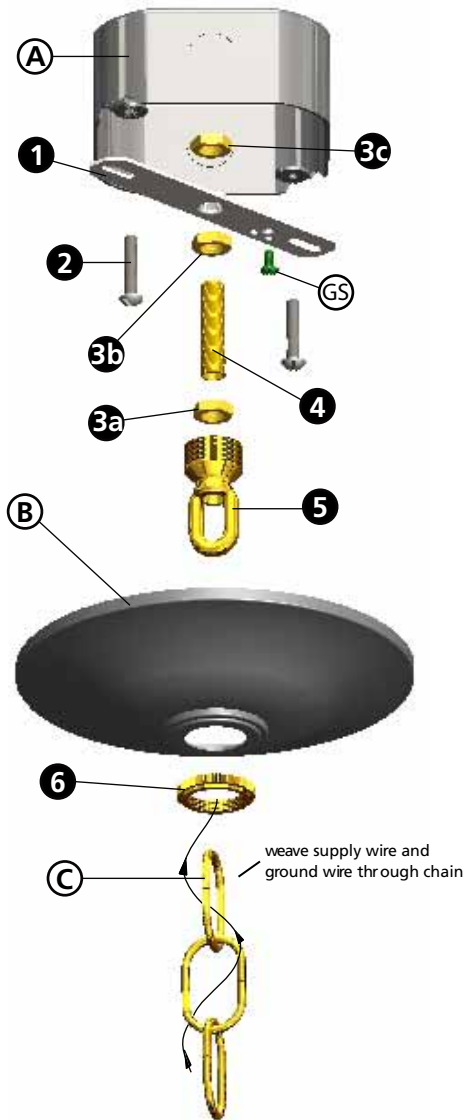

Drawing 2 Canopy Adjustment



SAFETY WARNING: READ WIRING AND GROUNDING INSTRUCTIONS (I.S. 18) AND ANY ADDITIONAL DIRECTIONS. TURN POWER SUPPLY OFF DURING INSTALLATION. IF NEW WIRING IS REQUIRED, CONSULT A QUALIFIED ELECTRICIAN OR LOCAL AUTHORITIES FOR CODE REQUIREMENTS.

1

1. Shut off electrical current before starting. If the fixture you are replacing is turned on and off by a wall switch, simply turn the switch off. If not, remove the appropriate fuse (or open the circuit breakers) until the fixture is dead.

- DO NOT restore current - either by fuse, breaker or switch - until the new fixture is completely wired and in place.

2

1. fasten mounting strap (1) to outlet box (A) with the two 8-32 screws (2) -see Drawing 1.

2. Thread 2 - hex nuts (3a) and (3b) onto threaded tubing (4).

3. Thread one end of threaded tubing (4) into loop (5) a minimum of 1/2" to 3/4". Tighten hexnut (3a) against loop (5) to lock loop in position.

4. Thread other end of threaded tube (4) into mounting strap approximately 1/2".

5. Slip canopy (B) over loop (5) and adjust height of loop so half of the threaded area on the loop is exposed - see **Drawing 2** below. After loop height is adjusted, tighten hex nut (3b) up against mounting strap, tighten against mounting strap to lock loop and threaded tube in position.

6. Remove mounting strap (1) from junction box (A), and thread third hex nut (3c) onto end of threaded tube (4) above the mounting strap, tighten against mounting strap to lock assembly in position.

7. Remount mounting strap to junction box.

3

1. Taking the chain, determine the length you require to hang the fixture.

2. Attach one end of the chain to the top loop of the fixture - see **Drawing 2**.

3. Now slip loop collar (5) and canopy (B) onto chain.

4. Attach other end of chain to loop (4). Get assistance for this step since fixture may be heavy and difficult to hold while attaching the chain.

4

1. Unwrap supply wire and ground wire and weave them up through the chain.

2. Slip supply wire and ground wire through center of loop (4).

3. Connect ground wire to mounting strap (1) using green ground screw (6).

4. Make electrical connections from supply wire to fixture lead wires. Refer to instruction sheet (I.S. 18) and follow all instructions to make all necessary wiring connections.

5. Slip canopy up firmly against the ceiling and secure by turning the threaded collar (5) on loop (4) until tight.

wiring grounding instructions

Drawing 1 - Flush Mount

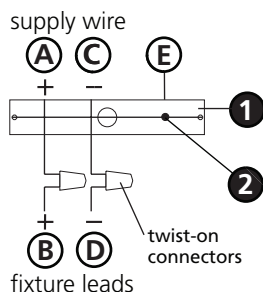

Drawing 2 - Chain Hung

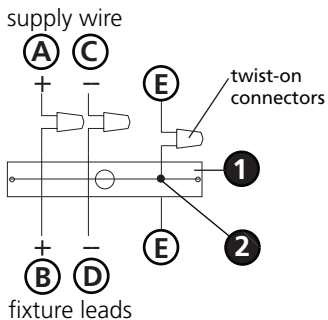

Drawing 3 - Post-Mount

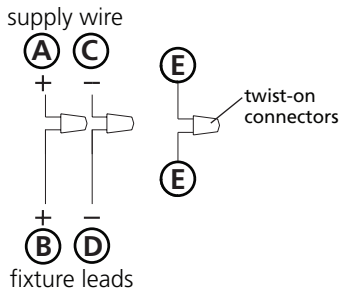

SAFETY WARNING: READ WIRING AND GROUNDING INSTRUCTIONS (I.S. 18) AND ANY ADDITIONAL DIRECTIONS. TURN POWER SUPPLY OFF DURING INSTALLATION. IF NEW WIRING IS REQUIRED, CONSULT A QUALIFIED ELECTRICIAN OR LOCAL AUTHORITIES FOR CODE REQUIREMENTS.

wiring instructions

Indoor Fixtures

1. Connect positive supply wire **(A)** (typically black or the smooth, unmarked side of the two-conductor cord) to positive fixture lead **(B)** with appropriately sized twist on connector - see **Drawings 1 or 2**.
2. Connect negative supply wire **(C)** (typically white or the ribbed, marked side of the two-conductor cord) to negative fixture lead **(D)**.
3. Please refer to the **grounding instructions** below to complete all electrical connections.

Outdoor Fixtures

1. Connect positive supply wire **(A)** (typically black or the smooth unmarked side of the two-conductor cord) to positive fixture lead **(B)** with appropriately sized twist on connector - see **Drawings 2 or 3**.
2. Connect negative supply wire **(C)** (typically white or the ribbed, marked side of the two-conductor cord) to negative fixture lead **(D)**.
3. Cover open end of connectors with silicone sealant to form a watertight seal.
 - If installing a wall mount fixture, use caulk to seal gaps between the fixture mounting plate (backplate) and the wall. This will help prevent water from entering the outlet box. If the wall surface is lap siding, use caulk and a fixture mounting platform specially.
4. Please refer to the **grounding instructions** below to complete all electrical connections.

grounding instructions

Flush Mount Fixtures

For positive grounding in a 3-wire electrical system, fasten the fixture ground wire **(E)** (typically copper or green plastic coated) to the fixture mounting strap **(1)** with the ground screw **(2)** - see **Drawing 1**.

Note: On straps for screw supported fixtures, first install the two mounting screws in strap. Any remaining tapped hole may be used for the ground screw.

Chain Hung Fixtures

Loop fixture ground wire **(E)** (typically copper or green plastic coated) under the head of the ground screw **(2)** on fixture mounting strap **(1)** and connect to the loose end of the fixture ground wire directly to the ground wire of the building system with appropriately sized twist-on connectors - see **Drawing 2**.

Post-Mount Fixtures

Connect fixture ground wire **(E)** (typically copper or green plastic coated) to power supply ground with appropriately sized twist-on connector inside post. Cover open end of connector with silicone sealant to form a watertight seal - see **Drawing 3**.