

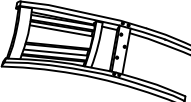

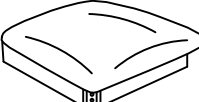

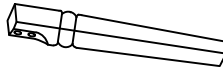

ASSEMBLY INSTRUCTION

SIDE CHAIR

A Chair Back  1pc	B Seat With Cushion  1pc	C Front Leg  2pcs	D Long Bolt 1/4" x 3"  4pcs
E Medium Bolt 1/4" x 2-1/2"  4pcs	F Short Bolt 1/4" x 1-1/2"  3pcs	G Lock Washer 5/16"  11pcs	H Flat Washer 5/16"  11pcs
I Allen Key 1/4" x 2-3/8"  1pc			

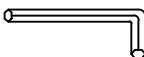
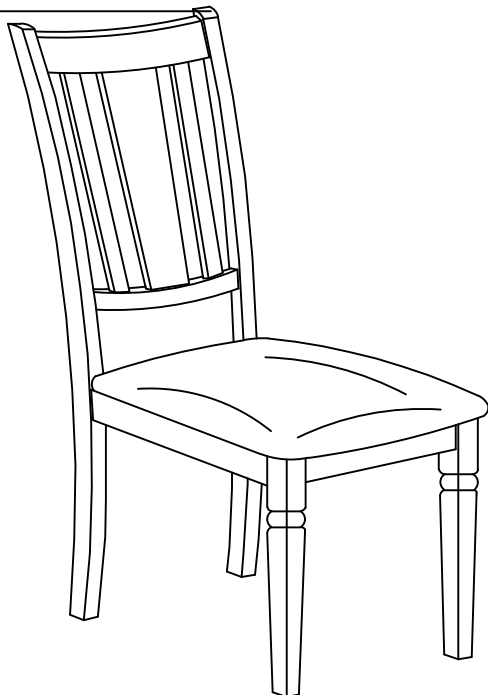

This page lists all the contents included in the box. Please take the time to identify the hardware as well as the individual components to this product. As you unpack and prepare for assembly, place the contents on a carpeted or padded area to protect them from damage.

1 Put Chair Back (A) on smooth flat surface. Attach Seat With Cushion (B) to the Chair Back (A) use Long Bolt (D), Short Bolt (F), Lock Washer (G) and Flat Washer (H) on five holes of the Chair Back (A). Turn the Allen Key (I) in the Long Bolt (D) and Short Bolt (F). But not too tight.

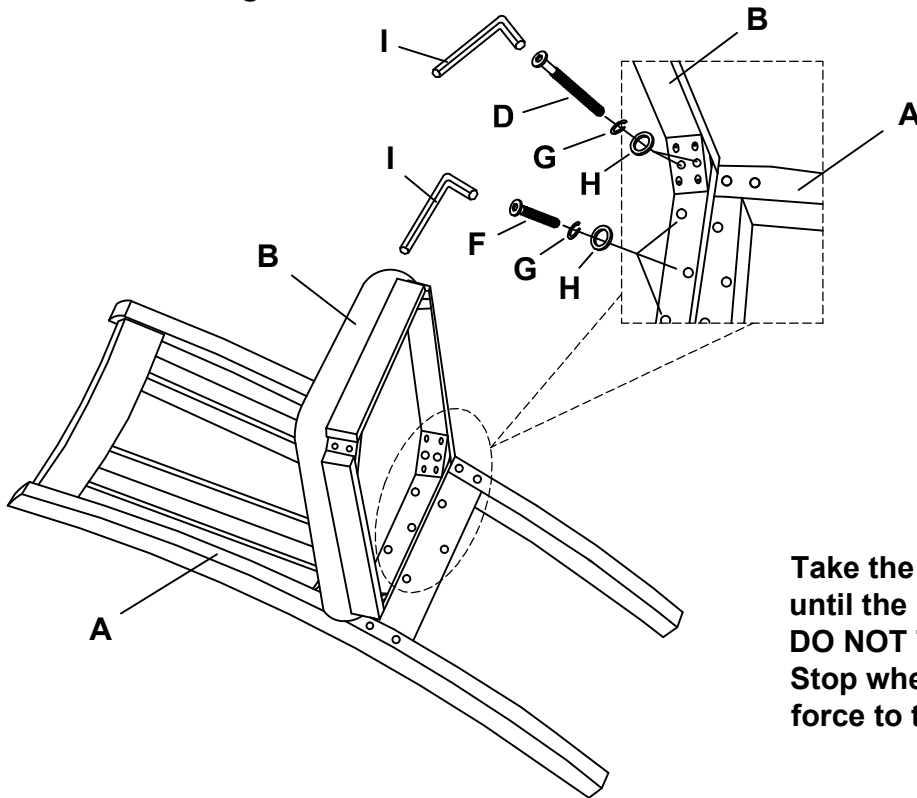

Take the Allen Key, and turn the bolts until the legs are secure. **DO NOT TIGHTEN COMPLETELY.** Stop when you feel you are adding force to tighten the bolt.

2 Attach Front Leg (C) to the Seat With Cushion (B) use Medium Bolt (E), Lock Washer (G) and Flat Washer (H) on both holes of the Seat With Cushion (B). Turn the Allen Key (I) in the Medium Bolt (E). But not too tight.

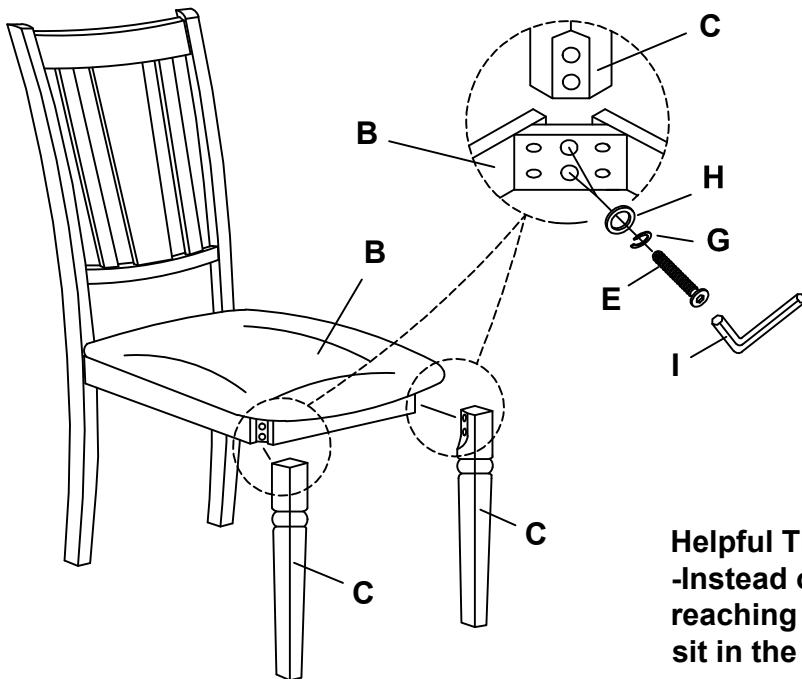

Stand chair up on an even surface and check that it is balanced. If there is a slight wobble, apply downward pressure in the corner where a leg is uneven. Keeping pressure in that corner, tighten all bolts. If balanced, apply downward pressure evenly in the center and tighten all bolts. Do not over-tighten beyond hole depth.

Helpful Tip:
-Instead of applying downward pressure while reaching under to tighten bolts, have someone sit in the chair while you tighten the bolts.

Cleaning & Care:

Treat surface with care. Surface is resistant to scratches but is not scratch resistant. Clean surfaces with a dry or damp soft cloth. Do not use abrasive cleaners. Hardware may loosen over time. Periodically check that all connections are tight.