

Kitchen Cart with one Drawer, two Doors and Adjustable Shelf

IMPORTANT NOTE

Carefully remove all the parts from the carton and put them individually on a soft cloth to prevent scratches or other damages occurring to the wood parts.

We have taken great care in the design of this product and request that you carefully and strictly follow our assembly instructions to ensure a completed product as it was designed.

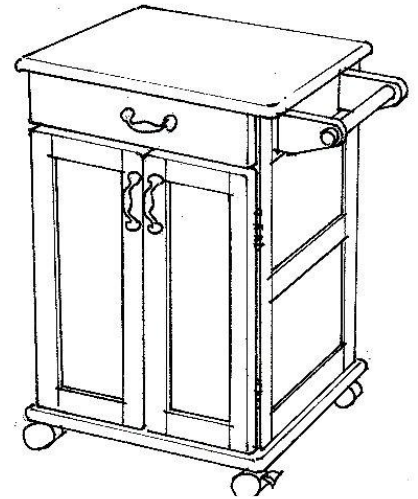

PART LIST

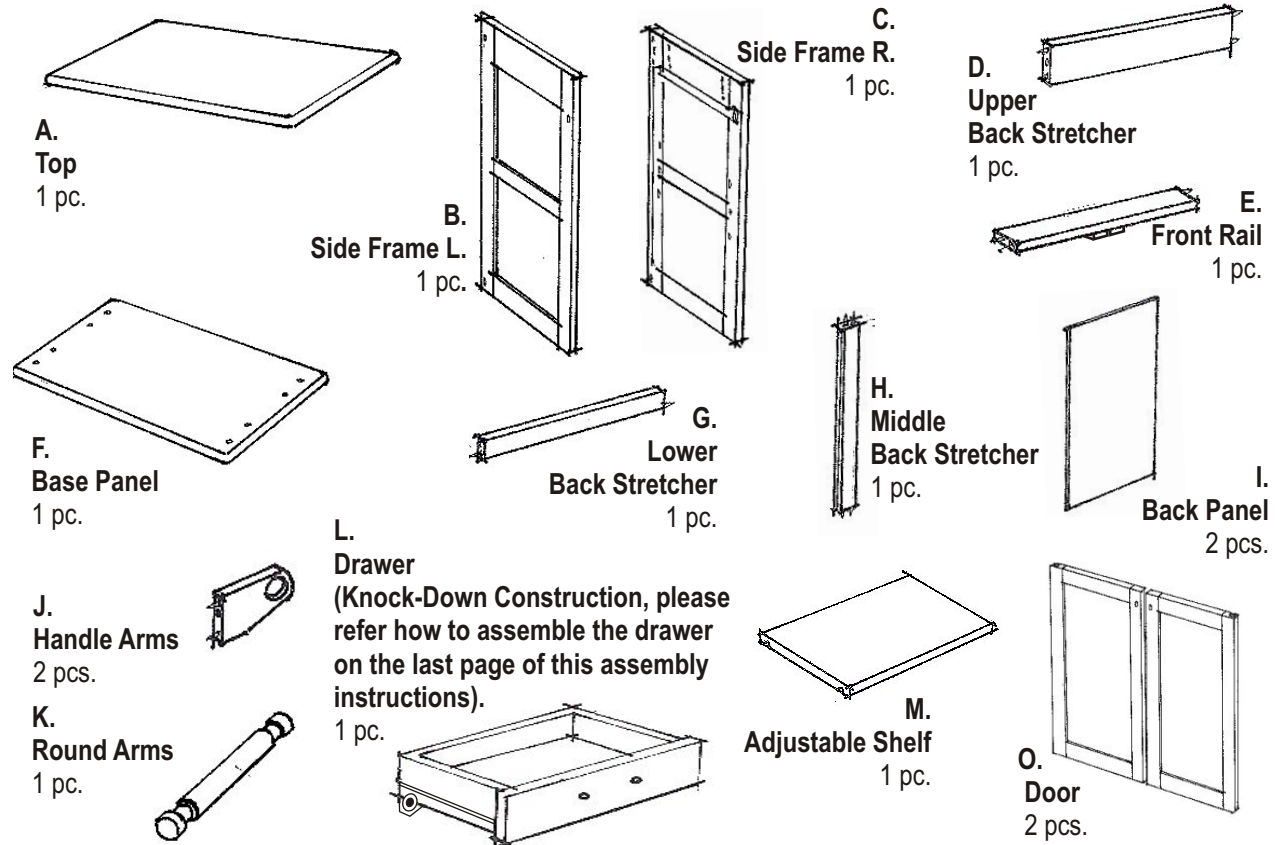

HARDWARE LIST

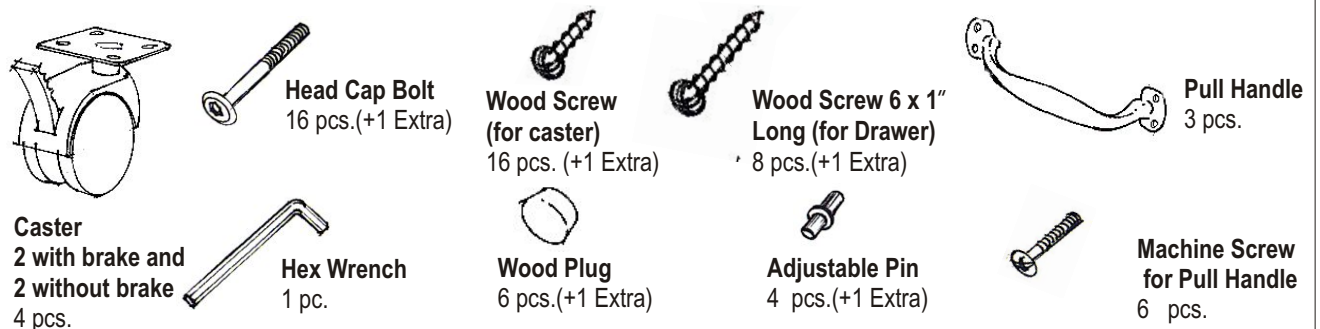

Tools Required For Assembly : Philips screwdriver

Assembly Instructions 2/4

IMPORTANT

Do not tighten up all the screws until each part is properly assembled.
You should keep Hex Wrench in the safe place as you may need to tighten up the Head Cap Bolts in the future.

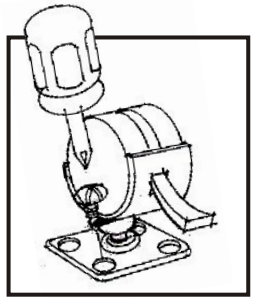

STEP 1

Attach 4 Casters to the under side of the Base Panel (F) with Wood Screws (I), put the 2 Casters with brakes in front as you first need to lock the cart from moving.

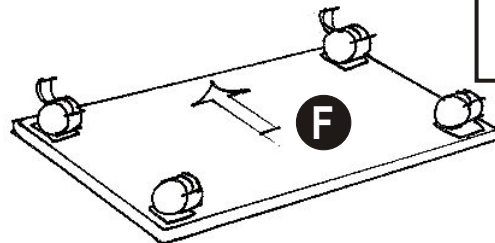

STEP 2

Attach the Side Frame L (B) to the Base Panel (F) with Head Cap Bolts.

Attach the Front Rail (E), Lower Back Stretcher (G) to the Assembled Unit. Tighten the Head Cap Bolts.

Attach the Middle Back Stretcher (H) to the Lower Back Stretcher (G), then slide the Back Panels (I) in place.

Attach the Upper Back Stretcher (D) to the Assembled Unit. Tighten the Head Cap Bolts.

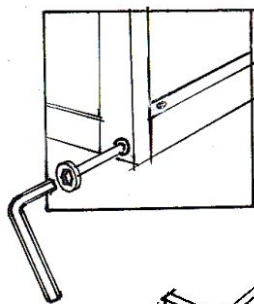
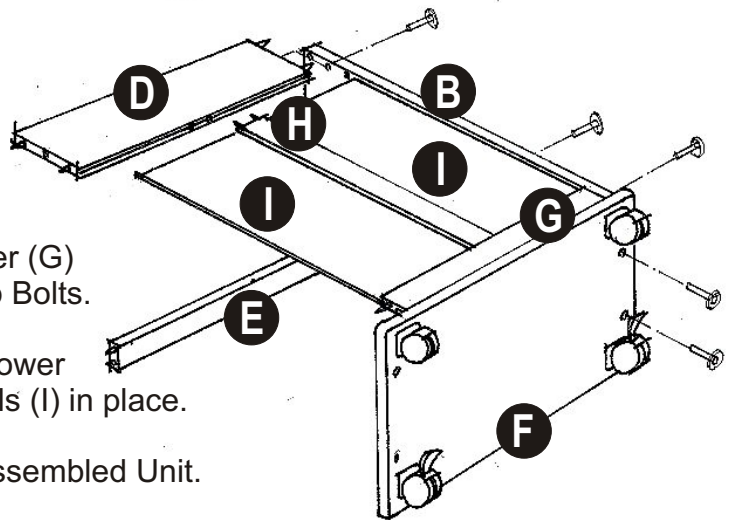

Tighten Head Cap Bolt by Hex Wrench.

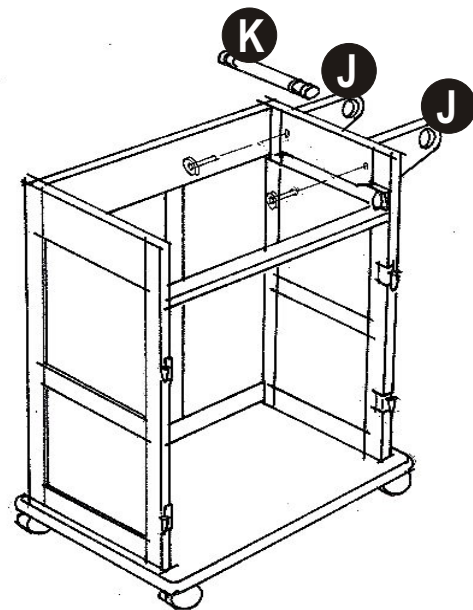
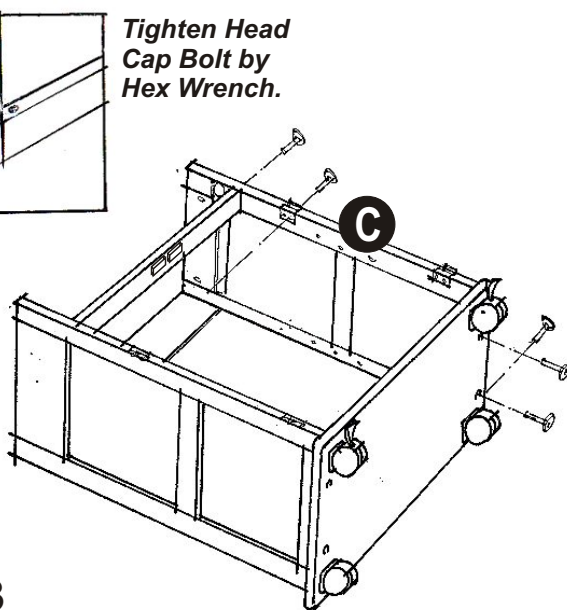

STEP 3

Attach the Side Frame R (C) to the Assembled Unit, then tighten Head Cap Bolts.

Attach the Handle Arms (J) using Head Cap Bolts from the inside of the both Side Frames and put the Round Arms (K) in place.

STEP 4

Attach the Top (A) to the Assembled Unit, tighten all the Head Cap Bolts through the Side Frame (B) and (C).

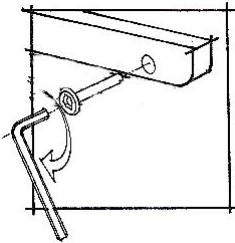

Top Assembly

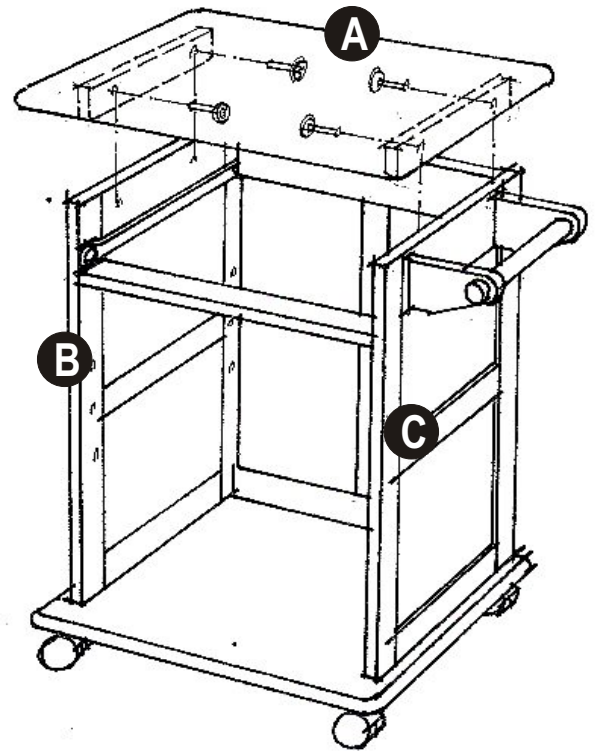

STEP 5

Attach the Doors (O) to the Assembled Unit.

Assemble the Door Pull Handles using the Machine Screws.

Insert the Adjustable Pins into the Side Panel, in the desired level. Place Adjustable Shelf (M) and Slide the Drawer (L) in place.

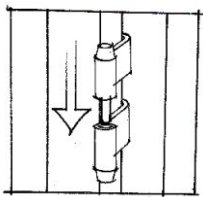

Door Assembly using Hinge

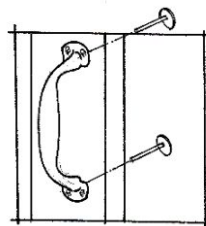

Pull Handle Assembly

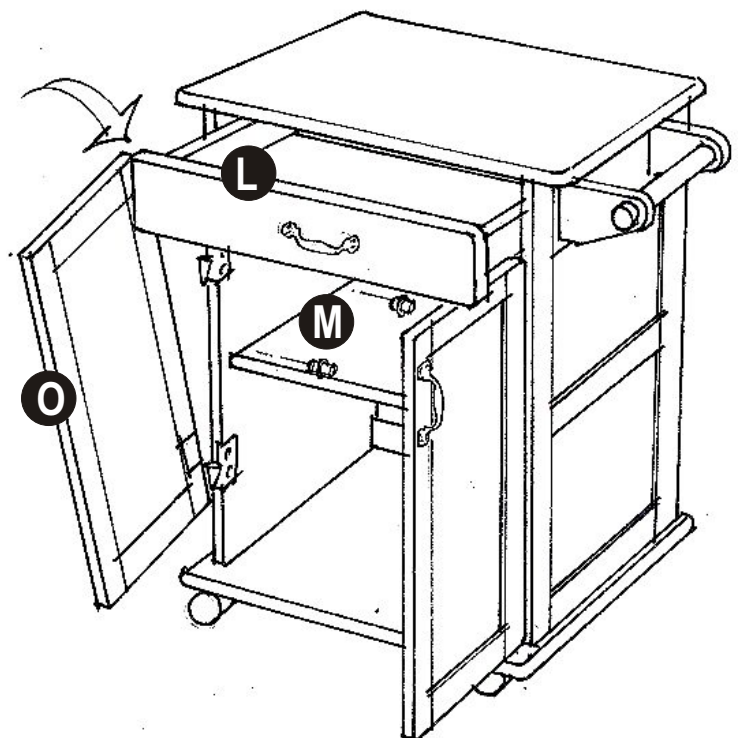

STEP 6

Cover all holes with Wood Plugs

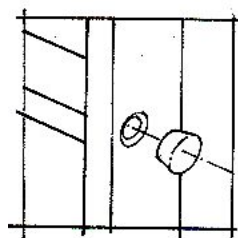

See the attached sheet for Drawer Assembly Instructions.

Drawer

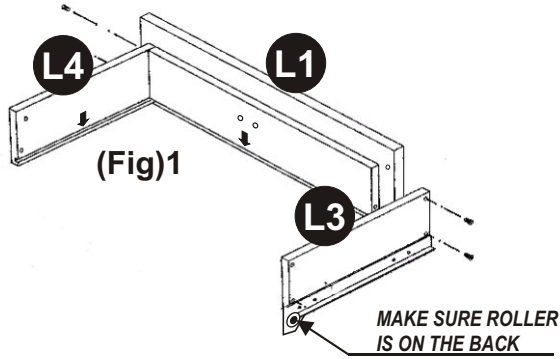

(Fig 1)

Line up Side Parts (L3) and (L4) to the Front Part (L1). Be sure to follow the *Arrow* sign sticker on the parts. Using a *Philips* screw driver, insert 1" screws (II) into each of the 4 pre-drilled holes in sides (L3) and (L4), then tighten half way.

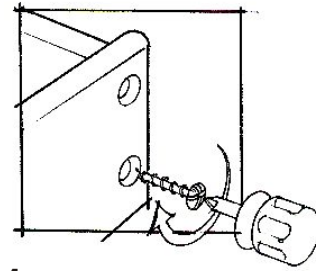

(Fig 2)

Turn the assembled drawer over and slide the Plywood Bottom Part (L5) into the grooves on Side Parts (L1), (L3) and (L4). Be sure to push the plywood all the way forward so it meets the Front Part (L1).

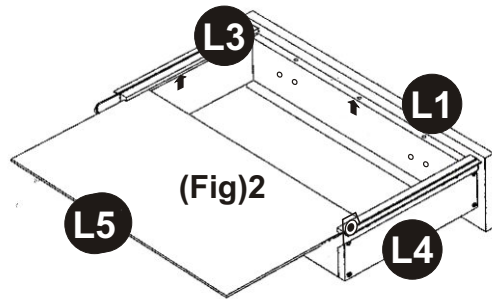

(Fig 3)

Attach the Back Part (L2) to the assembled drawer. Using a *Philips* screw driver, insert 1" screws (II) into each of the 4 pre-drilled holes in sides (L3) and (L4), then tighten all screws.

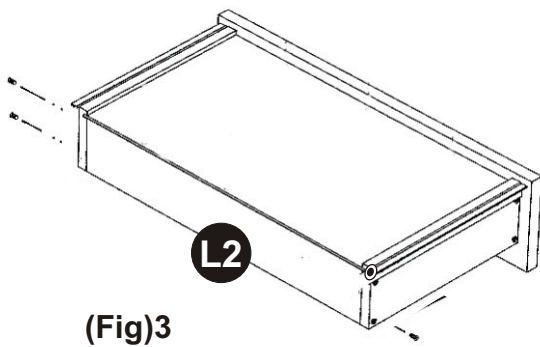

(Fig 4)

Assemble the Pull Handle with Machine Screw on the Front Part (L1).

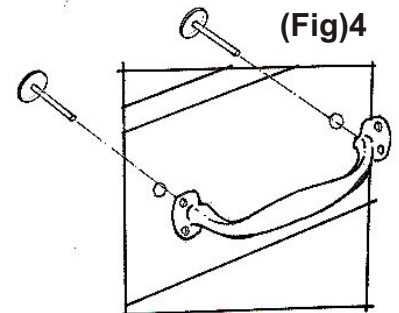

Unit Part List

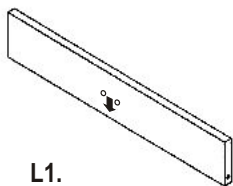

L1.
Front Part
1 pc.

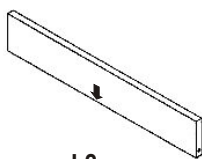

L2.
Back Part
1 pc.

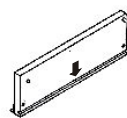

L3.
Side Part(L)
1 pc.

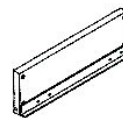

L4.
Side Part(R)
1 pc.

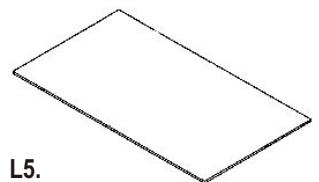

L5.
Bottom Part
1 pc.