**BERTAZZONI
OWNER'S MANUAL**

**GAS WORKTOP
ELECTRIC SELF CLEAN OVEN MODEL**



From the desk of the President

Dear new owner of a Bertazzoni,
I want to thank you for choosing one of our beautiful appliances for your home. We know that you have many brands and products to choose from, and we are thrilled that you have decided to take one of our products into your home.

We take as much pride in making our ranges as we hope you will in owning them. My family started manufacturing cooking appliances in 1882. Each of our products brings together Italian design and superior appliance technology. While we can not replace your unique talent at cooking delicious recipes for yourself, your family and your friends, we try our best to make cooking easier, more effective and more fun. And, at the same time, we strive to make your kitchen look beautiful.

Our appliances are designed according to the strictest safety and performance standard for the European and the North American market. We follow the most advanced manufacturing techniques. Each appliance leaves the factory after thorough quality inspection and testing. Our importers and our service partners are ready to answer any questions you may have regarding how to use and care for your Bertazzoni.

This manual will help you learn to use the product in the safest and most effective way and care for it so that it will give you the highest satisfaction for years to come.

Enjoy!



Pedro Bertazzoni

TABLE OF CONTENTS

WARNINGS	4
WORKTOP AND KNOBS LAYOUT	8
GAS COOKTOP	9
Burners caps and grates	9
Making sure the flame is optimal	9
Using the gas burners	9
Using the power burner	10
Gas shut-off safety - thermocouple	10
Using specialty cookware	10
Gas burner dimensions and recommended pan size	10
ELECTRIC GRIDDLE	11
Preparing the griddle	11
Seasoning the griddle	11
Using the electric griddle	11
Recommended griddle temperatures	11
MAIN ELECTRIC OVEN	12
Shelves positions	12
Cooling fan	12
Preheating the oven	12
Using the oven	12
Oven cooking modes	12
Special functions	13
AUXILIARY ELECTRIC OVEN	14
Shelves positions	14
Cooling fan	14
Preheating the oven	14
Using the oven	14
Oven cooking modes	14
Condensation	15
Getting the best results	15
Oven cooking recommendations	15
Broiling recommendations	16
Troubleshooting common problems with oven cooking	16
Oven temperature indicator	17
Self cleaning	18
Telescopic glides	20
KEEPING YOUR BERTAZZONI CLEAN	21
SIMPLE MAINTENANCE	22
Replacing oven lights	22
Cleaning inside glass door	23
TROUBLESHOOTING	24
TWO YEAR LIMITED WARRANTY	25

WARNINGS

Warning and Important Safety Instructions appearing in this manual are not meant to cover all possible conditions and situations that may occur. Common sense, caution, and care must be exercised when installing, maintaining, or operating the appliance.

Read and follow all instructions before using this appliance to prevent the potential risk of fire, electric shock, personal injury or damage to the appliance as a result of improper usage of the appliance. Use appliance only for its intended purpose as described in this manual.

Save this Manual for local electrical inspector's use. Read and save these instructions for future reference. Observe all governing codes, ordinances and regulations.

Warning!

To avoid risk of property damage, personal injury or death; follow information in this manual exactly to prevent a fire or explosion. DO NOT store or use gasoline or other flammable vapors and liquids nearby this or any appliance.

What to do if you smell gas:

Do not light any appliance. Do not touch any electrical switch. Do not use any phone in your building. Immediately call your gas supplier from a neighbor's phone. Follow the gas supplier's instructions. If you cannot reach your gas supplier, call the fire department.

NOTE: Installation and service must be performed by a qualified installer, service agency or the gas supplier.

In Massachusetts:

All gas products must be installed by a "Massachusetts" licensed plumber or gasfitter. A "T" handle type manual gas valve must be installed in the gas line connected to this appliance.

To ensure proper and safe operation: Appliance must be properly installed and grounded by a qualified technician. DO NOT attempt to adjust, repair, service, or replace any part of your appliance unless it is specifically recommended in this manual. All other servicing should be referred to a qualified servicer. Have the installer show you the location of the gas shut-off valve and how to shut it off in an emergency.

A certified technician is required for any adjustments or conversions to Natural or LP gas.

To Prevent Fire or Smoke Damage

- Be sure all packing materials are removed from the appliance before operating it.
- Never let clothing, potholders, or other flammable materials come in contact with or too close to any element, top burner or burner grate until it has cooled.
- If appliance is installed near a window, proper precautions should be taken to prevent curtains from blowing over burners.
- Never leave any items on the cooktop. The hot air from the vent may ignite flammable items and may increase pressure in closed containers which may cause them to burst.
- Many aerosol-type spray cans are EXPLOSIVE when exposed to heat and may be highly flammable. Avoid their use or storage near an appliance.

In Case of Fire

Turn off appliance and ventilation hood to avoid spreading the flame. Extinguish flame then turn on hood to remove smoke and odor.

- Cooktop: Smother fire or flame in a pan with a lid or cookie sheet.
- NEVER pick up or move a flaming pan.
- Oven: Smother fire or flame by closing the oven door. DO NOT use water on grease fires. Use baking soda, a dry chemical or foamtype extinguisher to smother fire or flame, if available, a multipurpose dry chemical or foam type extinguisher.

Child Safety

- NEVER leave children alone or unsupervised near the appliance when it is in use or is still hot.
- NEVER allow children to sit or stand on any part of the appliance as they could be injured or burned.
- DO NOT store items of interest to children over the unit. Children climbing to reach those items could be seriously injured.

Cooking Safety

- Once the unit has been installed as outlined in the Installation Instructions, it is important that the fresh air supply is not obstructed. The use of a gas cooking appliance results in the production of heat and moisture in the room in which it is installed.
- Ensure that the kitchen is well-ventilated. Keep natural venting holes open or install a mechanical ventilation device. Prolonged or intensive use of the appliance may call for additional (such as opening a window) or more effective ventilation (such as increasing the level of a mechanical ventilation if present).
- NEVER use aluminum foil to cover oven racks or oven bottom. This could result in risk of electric shock, fire, or damage to the appliance. Use foil only as directed in this guide.
- To eliminate the hazard of reaching over hot surface burners, cabinet storage should not be provided directly above a unit. Temperatures may be unsafe for some items, such as volatile liquids, cleaners or aerosol sprays.
- ALWAYS place a pan on a surface burner before turning it on. Be sure you know which knob controls which surface burner. Make sure the correct burner is turned on and that the burner has ignited. When cooking is completed, turn burner off before removing pan to prevent exposure to burner flame.
- ALWAYS adjust surface burner flame so that it does not extend beyond the bottom edge of the pan. An excessive flame is hazardous, wastes energy and may damage the appliance, pan or cabinets above the appliance. This is based on safety considerations.
- NEVER leave a surface cooking operation unattended especially when using a high heat setting or when deep fat frying. Boilovers cause smoking and greasy spillovers may ignite. Clean up greasy spills as soon as possible. DO NOT use high heat for extended cooking operations.
- DO NOT heat unopened food containers, build up of pressure may cause the container to explode and result in injury.
- ALWAYS let quantities of hot fat used for deep fat frying cool before attempting to move or handle.
- NEVER wear garments made of flammable material or loose fitting or long-sleeved apparel while cooking. Clothing may ignite or catch utensil handles. DO NOT drape towels or materials on oven door handles. These items could ignite and cause burns.
- ALWAYS place oven racks in the desired posi-

tions while oven is cool. Slide oven rack out to add or remove food, using dry, sturdy potholders.

- ALWAYS avoid reaching into the oven to add or remove food. If a rack must be moved while hot, use a dry pot-holder.
- ALWAYS turn the oven off at the end of cooking.
- Use care when opening the oven door. Let hot air or steam escape before moving or replacing food.
- DO NOT cook directly on the oven bottom. This could result in damage to your appliance. Always use the oven racks when cooking in the oven.

Do not connect any appliances to the plugs above or near to the induction cooktop; connection cable insulation can melt if in contact with heat, and this may result in an injury and a property damage.

Recommended Utensils

- Use pans with flat bottoms and handles that are easily grasped and stay cool. Avoid using unstable, warped, easily tipped or loose-handled pans. Also avoid using pans, especially small pans, with heavy handles as they could be unstable and easily tip. Pans that are heavy to move when filled with food may also be hazardous.
- Be sure utensil is large enough to properly contain food and avoid boilovers. Pan size is particularly important in deep fat frying. Be sure pan will accommodate the volume of food that is to be added as well as the bubble action of fat.
- To minimize burns, ignition of flammable materials and spillage due to unintentional contact with the utensil, DO NOT extend handles over adjacent surface burners. ALWAYS turn pan handles toward the side or back of the appliance, not out into the room where they are easily hit or reached by small children.
- NEVER let a pan boil dry as this could damage the utensil and the appliance.
- Follow the manufacturer's directions when using oven cooking bags.
- Only certain types of glass, glass/ceramic, ceramic or glazed utensils are suitable for range-top surface or oven usage without breaking due to the sudden change in temperature. Follow manufacturer's instructions when using glass.

Induction Cooking Surfaces

- Surface areas on or adjacent to the unit may be hot enough to cause burns. Do not touch the cooking area as long as the light indicating residual heat on the glass-ceramic cooktop area, is “on”; this indicates that the temperature in the relative area is still high.
- DO NOT COOK ON BROKEN COOKING SURFACE – If cooking surface should break, cleaning solutions and spillovers may penetrate the broken cooking surface and create a risk of electric shock. Contact a qualified technician immediately.
- Keep a close eye on children because they are unlikely to see the residual heat warning lights. The cooking zones are still very hot for some time after use, even if they are switched off. Make sure that children never touch them.
- NEVER use aluminum foil to hold the food while cooking on a glass-ceramic cooktop area.
- Never place pan with bottoms which are not perfectly flat and smooth on the cooktop area.
- If you drop a heavy pot on your cooktop area it will not break. On the contrary, if a hard object, such as the salt shaker or the spice bottle strikes the edge or the corner of the cooktop area, the cooktop area may break.
- Never use the glass-ceramic cooktop area as support surface.
- Only use cleaning products made specifically for ceramic glass cooking surfaces.
- Metal items such as cutlery or lids must never be placed on the surface of the cooktop area since they may become hot.

Radio Interference - Induction Ranges

This unit generates, uses, and can radiate radio frequency energy and, if not installed and used in accordance with the instructions, may cause harmful interference to radio communications. However, there is no guarantee that interference will not occur in a particular installation. If this unit does cause harmful interference to radio or television reception, which can be determined by turning the unit off and on, the user is encouraged to try to correct the interference by one or more of the following measures:

- Reorient or relocate the receiving antenna
- Increase the distance between the unit and receiver
- Connect the unit into an outlet on a circuit different from that to which the receiver is connected.

Oven Heating Elements

- NEVER touch oven bake and broil burner areas or interior surfaces of oven.
- Bake and broil burners may be hot even though they are dark in color. Areas near burners and interior surfaces of an oven may become hot enough to cause burns.
- During and after use, DO NOT touch or let clothing or other flammable materials contact heating elements, areas near elements, or interior surfaces of oven until they have had sufficient time to cool. Other surfaces of the oven may become hot enough to cause burns, such as the oven vent opening, the surface near the vent opening, and the oven door window.

Cleaning Safety

- Turn off all controls and wait for appliance parts to cool before touching or cleaning them. DO NOT touch the burner grates or surrounding areas until they have had sufficient time to cool.
- Clean the range with caution. Avoid steam burns; DO NOT use a wet sponge or cloth to clean the range while it is hot. Some cleaners produce noxious fumes if applied to a hot surface. Follow directions provided by the cleaner manufacturer.
- DO NOT clean, rub, damage, move or remove the door gasket. It is essential for a good seal during baking. If the gasket becomes worn or excessively soiled with food particles, replace gasket to assure a tight seal.

Power failure warning

Due to safety considerations and the possibility of personal injury in attempting to light and extinguish the oven burners, the grill and the oven burner should not be used during a power failure. The oven control knob should always remain in the “OFF” position during a power failure.

NEVER use appliance as a space heater to heat or warm a room to prevent potential hazard to the user and damage to the appliance. Also, DO NOT use the rangetop or oven as a storage area for food or cooking utensils.

Electrical shock hazard

Make sure all controls are OFF and oven is COOL before cleaning. Failure to do so can result in burns or electrical shock.

DO NOT touch a hot oven light bulb with a damp cloth as the bulb could break. Should the bulb break, disconnect power to the appliance before removing bulb to avoid electrical shock.

NEVER cover any slots, holes or passages in the oven bottom or cover an entire rack with materials such as aluminum foil. Doing so blocks air flow through the oven and may cause carbon monoxide poisoning. Aluminum foil linings may also trap heat, causing a fire hazard.

Burn hazard

The oven door, especially the glass, can get hot. DO NOT touch the oven door glass!

Warning-tipping hazard

Children and adults can tip over the range if it has not been secured. This may lead to fatal injuries.



To reduce the risk of the appliance tipping, it must be secured and connected using the anti-tip device according to the installation instructions. Re-engage the anti-tip device if the range is moved.

Do not operate the range without the anti-tip device in place and engaged. Do not use the range if the anti-tip device has not been properly installed and engaged. See installation instructions for details.

Failure to observe the information contained in the installation instructions can lead to serious or fatal injuries for children and adults.

WORKTOP AND KNOBS LAYOUT

Heating element

- | | |
|---|-------------------------|
| 1 | Oven functions selector |
| 2 | Oven thermostat |
| 3 | Left front burner |
| 4 | Left rear burner |
| 5 | Right front burner |
| 6 | Right rear burner |

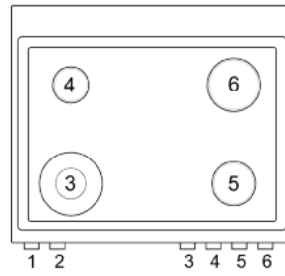

Heating element

- | | |
|---|----------------------|
| 1 | Left front burner |
| 2 | Left rear burner |
| 3 | Left front burner |
| 4 | Left rear burner |
| 5 | Central front burner |
| 6 | Central rear burner |
| 7 | Right front burner |
| 8 | Right rear burner |

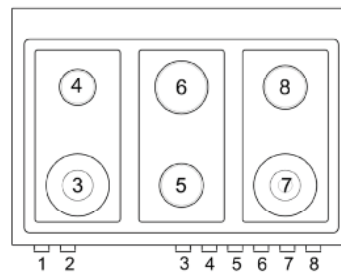

Heating element

- | | |
|----|---------------------------|
| 1 | Oven functions selector |
| 2 | Oven thermostat |
| 3 | Left front burner |
| 4 | Left rear burner |
| 5 | Central front burner |
| 6 | Central rear burner |
| 7 | Right front burner |
| 8 | Right rear burner |
| 9 | Auxiliary oven thermostat |
| 10 | Electric griddle |

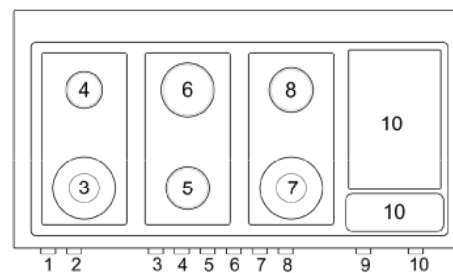

GAS COOKTOP

BURNER CAPS AND GRATES

The burners and the burner caps must be properly placed for the cooktop to function properly.

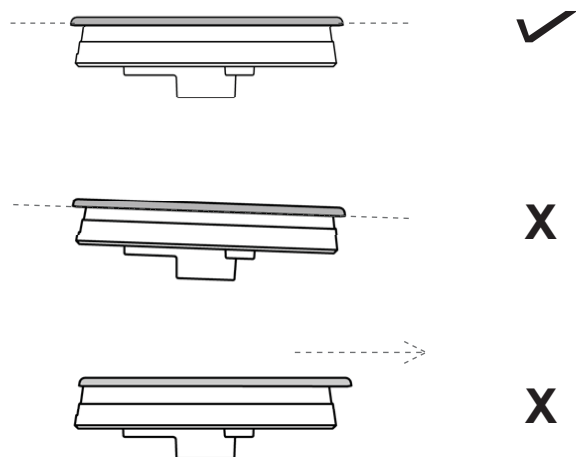

The burner grates must be properly placed inside the recess on the cooktop.

MAKING SURE THE FLAME IS OPTIMAL

The flame should be stable with no excessive noise or fluttering. The color should be blue with no yellow on the tips. It is not uncommon to see orange in the flame color; this indicates the burning of airborne impurities in the gas and will disappear with use.

- With propane (LP) gas, slight yellow tips on the primary icon are normal.
- The flame should burn completely around the burner cap. If it doesn't, check that the cap is positioned correctly on the base and that the ports are not blocked.



yellow flames:
further adjustment is required

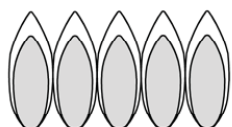

yellow tips on outer cones:
normal for LP gas



soft blue flames:
normal for natural gas

The correct flame height depends on:

- size and material of pan being used
- food being cooked
- amount of liquid in the pan.

Never extend the flame beyond the base of the pan. Use a low or medium flame for pan materials that conduct the heat slowly, such as porcelain coated steel or glass-ceramic.

Because the edges of the flame are much hotter than its center, the flame tips should stay beneath the bottom of the cookware. Flame tips which extend beyond the sides of the cookware emit unnecessary heat into the room and can also damage cookware handles, which increases the risk of injury.

USING THE GAS BURNERS

- Press in the control knob and turn it anti-clockwise, to HIGH position.
- Continue to hold the knob in for 5 to 10 seconds after the burner ignition before releasing
- Adjust flame with the knob as needed.

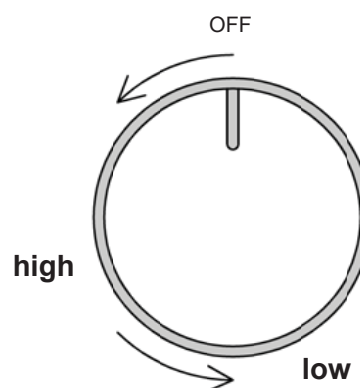

USING THE POWER BURNER

To give further flexibility, the dual power burner can be used as a single simmer burner if the central burner alone is ignited or as a power burner if the outer burner is also ignited.

To light the central burner, press in the control knob and turn it anti-clockwise to the HIGH of the single ring position

Continue to hold the knob in for 5 to 10 seconds after the burner ignites before releasing

To also light the outer burner, turn the knob to the HIGH double ring. Adjust the flame as required.

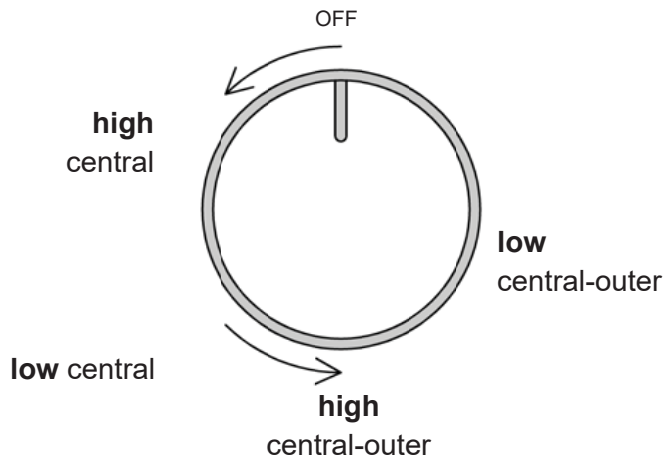

GAS SHUT-OFF SAFETY - THERMOCOUPLE

A flame failure device (thermocouple) on each burner acts as a safety gas cut-off in case the flame is accidentally blown out. A thermocouple detects the absence of a flame and stops the supply of gas. The thermocouple must be heated for a few seconds when the burner is ignited before the knob is released.

USING SPECIALTY COOKWARE

Woks

Either flat-based or round-bottom woks with the accessory ring can be used on all models. Round bottom woks must be used with a support ring. In some models the porcelain-coated cast iron wok support ring must be purchased separately.

Simmer ring

For very slow cooking the porcelain coated simmer ring should be used. In some models the porcelain-coated cast iron simmer ring must be purchased separately.

Simmer ring must be used for pan with diameter less than 4 inches.

NOTE: In the event of a power failure, the burners can be lit with a match or gas lighter. The flame failure devices will continue to function normally.

GAS BURNER DIMENSIONS AND RECOMMENDED PAN SIZE

Burner	Diam. in (mm)	Diam. of pan	Utilization
Auxiliary	Ø 2" (50mm)	Ø 3"1/2- 5"1/2 (90-140mm)	Use with smaller pans for boiling and simmering and the preparation of sauces.
Semi-rapid	Ø 2"3/4 (70mm)	Ø 5"1/2 -10"1/4 (140-260mm)	Use for normal frying and boiling in medium and small pans.
Rapid	Ø 3"3/4 (95 mm)	Ø 7"1/8 -10"1/4 (180-260 mm)	Use with large and medium pans of water for frying and rapid boiling.
Dual inner/outer	Ø1"11/16-5"1/2 (43-140 mm)	Ø 8"2/3 -10"1/4 (220-260 mm)	Use with woks, griddle's and frying pans or for large pans and rapid boiling.

ELECTRIC GRIDDLE

Available on 48" models only

The electric stainless steel griddle is manufactured from 3/16 inches stainless steel designed for maximum heat retention. Use extreme caution when operating the griddle to avoid burn hazard!

PREPARING THE GRIDDLE

- Check the griddle plate adjustment by pouring two tablespoons of water on the back of the griddle plate. The water should slowly roll into the grease tray.
- To adjust move the griddle plate to the side (Figure 23).
- Adjust the two screws under the back of the plate. Start with one half turn counterclockwise of the screws. Further adjustment should be made by one-quarter turn until water slowly flows into the grease tray.

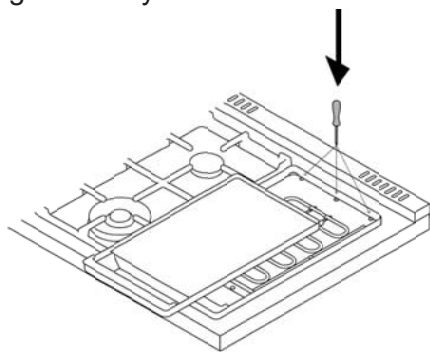

SEASONING THE GRIDDLE

The stainless steel griddle must be seasoned before using it for the first time. We also recommend re-seasoning after a long time of non use.

- Clean the griddle thoroughly with hot water and soap solution to remove any protective coating.
- Rinse with a mixture ¼ gal of water and 1 cup white vinegar and dry thoroughly.
- Pour 1 tsp vegetable oil into the centre of the griddle. Rub the oil over the entire surface of the griddle using a heavy cloth.
- Turn the control knob to a maximum setting.

- Turn the heat off when the oil begins to smoke. Allow the griddle to cool.
- Repeat step 3 covering the entire surface with the oil. Turn off the heat and allow the griddle to cool.
- Wipe the entire surface of the griddle using a heavy cloth.
- Apply a very thin layer of vegetable oil. The griddle is now ready for use, too much oil can damage the griddle

USING THE ELECTRIC GRIDDLE

Press and turn the knob (Fig. 16) anti-clockwise to the selected position. The activation of the griddle is shown by the indicator light which is also found on the front panel of the appliance.

Pre-heat at the maximum temperature for 15 minutes, then place the food on the griddle and cook at the desired temperature.

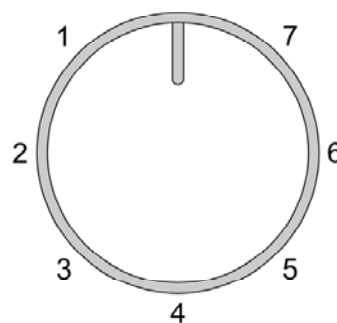

You can cook on the electric griddle without butter, margarine or oil. However, a very small amount may be used to flavor foods.

DO NOT use metal utensils on the griddle surface. Care should be taken that the surface is not scratched or gouged with utensils.

DO NOT use knives for cutting directly on the griddle plate.

RECOMMENDED GRIDDLE TEMPERATURES

Food	Knob position	Setting
Eggs	3	300°F to 325°F
Bacon; Breakfast Sausage	3 - 4	350°F to 375°F
Toasted Sandwiches	3	325°F to 350°F
Boneless Chicken Breasts	3 - 4	350°F to 375°F
Boneless Pork Chops (15 mm thick)	3 - 4	350°F to 375°F
Ham Slices (15 mm thick)	3 - 4	350°F to 375°F
Pancakes; French Toast	3 - 4	350°F to 375°F
Potatoes; Hash Browns	4 - 5	375°F to 400°F

MAIN ELECTRIC OVEN

Attention!

When using the oven for the first time it should be operated for 15-30 minutes at a temperature of about 500°F/260°C without cooking anything inside in order to eliminate any moisture and odours from the internal insulation.

SHELVES POSITIONS

Shelves are mounted on the appropriate guides situated on the sides of the oven compartment. Insert the shelf between top and bottom guide in any of the 7 positions indicated.

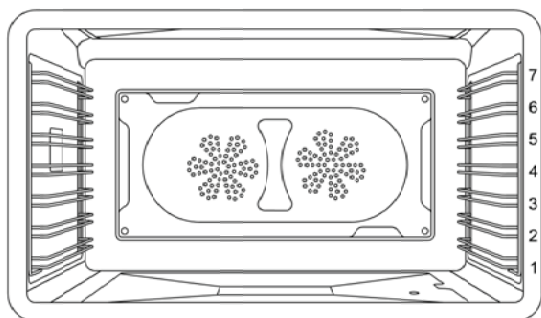

COOLING FAN

The range is equipped with a cooling fan designed to prevent the control panel and knobs from overheating. The cooling fan will operate when the oven temperature goes up. It will turn off when the temperature decreases.

NOTE: It is normal for the cooling process to push heated air out into the room when the oven is on.

PREHEATING THE OVEN

Most cooking times in recipes are intended for a preheated oven and require that the oven already be at the set temperature before placing food in the oven. Preheating time depends on the temperature setting and the number of racks in the oven.

USING THE OVEN

1. Place rack in desired position and shut the door.
2. Select the oven function with the dedicated function knob. The light in the cavity will turn on.
3. Set the desired temperature with the dedicated selector knob.

The oven will start PRE-HEATING in a few seconds showing the progress in the gauge. The end of pre-heating will be confirmed with a tone. Place the food in the oven when the desired temperature has been reached.

OVEN COOKING MODES

The oven is equipped with 4 heating elements, used alone or in combination to create different cooking modes:

- Upper bake element
- Lower bake element
- Broil element
- Convection element

The temperature setting and cooking times can vary slightly from one oven to another. It is possible that recipes and cooking times need to be adjusted accordingly.

Bake

Heat from upper and lower element

Use this setting for baking, roasting, and casseroles on a single rack.

- Standard bake: level 3 or 4
- Taller items: level 3
- Pies: level 2 or 3 to ensure the bottom of the crust is done without over-browning the top.
- Large cuts of meat or poultry: level 2.

Convection bake

Heat from upper and lower bake element and air flow convection with fan.

Use this setting to bake and roast different foods at the same time with no taste transfer. The fan circulates the hot air around the oven for uniform cooking of larger quantities of food. Use for roasting vegetables, meat and poultry, or baked fish. This function is the best one for cooking frozen products and breaded/battered chicken or fish. It may be used for cakes, cookies, biscuits and other foods on multiple racks.

Use the same rack position as BAKE. When using 2 racks, use level 3 and 5.

Pizza

Heat from lower bake element and circular element and airflow convection with fan.

Use for cooking pizza, pastry or flat breads to get a perfectly cooked base.

Use level 3 or level 2 to ensure the bottom of the crust is done.

Broil

Heat from the broil element only

The BROIL setting creates intense heat from the top of the cavity. The broil mode is effective when food is placed on upper racks.

- Beef steaks, ground meat patties, and lamb chops 1 inch or less: level 6.
- Meat 1 inches or more thick, fish, poultry, pork chops, ham steaks 1 inch or more: level 5.
- Browning food: level 6 (no longer than 15mins)

Convection broil

Heat from broil element and air flow convection with fan.

Use this setting for browning and cooking food evenly on all sides, including bottom. Also recommended for food that is too delicate to turn over such as fish. The fan circulates hot air around the food helping to cook it all the way through. The degree of browning on each side might be different.

The conv broil mode must be used on one rack,

- sausages and chicken portions: level 5 or 6
- foods with high water content such as bacon and chops: level 5 or 6 (door closed 400°F)

Convection

Heat from the convection element and airflow convection with fan.

Use this mode for most recipes being careful at calibrating the time. Less time is usually required to reach the desired result when using convection. The temperature is kept uniform throughout the oven, which is particularly suitable for baking on several levels or for batch cooking.

- Single rack: use the same rack position as bake
- 2 racks: use level 3 and 5
- 3 racks : use level 2 ,4, 6

Clean

Heat from upper and lower element.

Use this settint for cleaning the oven with a pyrolytic self-cleaning cycle.

Turn the temperature knob to clean (see chapter SELF-CLEANING)

SPECIAL FUNCTION/WARMING**Dehydrate**

Heat from lower element and air flow convection with fan.

Use this setting for dehydrate food, flowers, vegetables.

Turn the temperature knob to 100°F

Use level 2 or 3

Proofing

Heat from lower element.

Use this setting to maintain the warm, needed for proofing yeast. It is best to start with a cool oven when using the proofing function.

Turn the temperature knob to 150°F

Do not open the oven door unnecessarily

Use level 2 or 3

Warming

Heat from lower element.

Use this setting to keep warm the food at the temperature of 170°F(77°C).

Turn the temperature knob to 200°F

Use level 2 or 3

AUXILIARY ELECTRIC OVEN

Available on 48" models only

Attention!

When using the oven for the first time it should be operated for 15-30 minutes at a temperature of about 500°F/260°C without cooking anything inside in order to eliminate any moisture and odours from the internal insulation.

SHELVES POSITIONS

Shelves are mounted on the appropriate guides situated on the sides of the oven compartment. Insert the shelf between top and bottom guide in any of the 7 positions indicated.

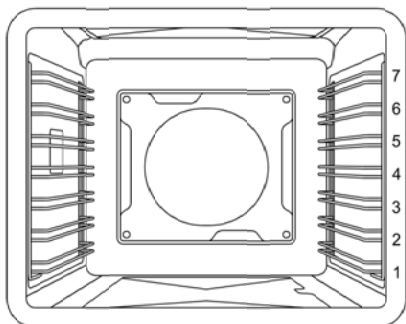

COOLING FAN

Automatic operation of the cooling fan
The range cooker is equipped with a thermostatically controlled cooling fan designed to prevent the control panel and knobs from overheating. The cooling fan will operate when the oven temperature rises. It will turn off when the temperature decreases.

NOTE: It is normal for the cooling process to push heated air out into the room when the oven is on.

PREHEATING THE OVEN

Most cooking times in recipes are intended for a preheated oven and require that the oven already be at the set temperature before placing food in the oven. Preheating time depends on the temperature setting and the number of racks in the oven.

USING THE OVEN

1. Place rack in desired position and shut the door.
2. The electric oven is controlled by an electric thermostat combined with a switch. Select the oven function /temperature with the dedicated knob. The light in the cavity will turn on.

OVEN COOKING MODES

The oven is equipped with 3 heating elements, used alone or in combination to create different cooking modes:

- Upper bake element
- Lower bake element
- Broil element

The temperature setting and cooking times can vary slightly from one oven to another. It is possible that recipes and cooking times need to be adjust accordingly.

Bake (From 150° to MAX)

Heat from upper and lower element

Use this setting for baking, roasting, and casseroles on a single rack.

- Standard bake: level 3 or 4
- Taller items: level 3
- Pies: level 2 or 3 to ensure the bottom of the crust is done without over-browning the top.
- Large cuts of meat or poultry: level 2.

Bottom Bake

Heat from lower element

In this function the temperature is fixed at max. setting. (500°F/260°C).

Use on a single rack.

- Standard bake: level 1 or 2

Upper Bake

Heat from upper element

In this function the temperature is fixed at max. setting. (500°F/260°C).

Use on a single rack.

Standard bake: level 5 or 6

Broil

Heat from the broil element only

The BROIL setting creates intense heat from the top of the cavity. The broil mode is effective when food is placed on upper racks.

- Beef steaks, ground meat patties, and lamb chops 1 inch or less: level 6.
- Meat 1 inches or more thick, fish, poultry, pork chops, ham steaks 1 inch or more: level 5.
- Browning food: level 6 (no longer than 15mins)

Light

Use this function to light the oven when the oven is off (for example to manual clean the oven).

CONDENSATION

It is normal for a certain amount of moisture to evaporate from the food during any cooking process. The amount depends on the moisture content of the food. The moisture will condense on any surface cooler than the inside of the oven, such as the control panel.

Using aluminum foil in the oven

Foil can be used to cover food in the oven but this should not come into close proximity with the oven elements. Foil should not be used to line the oven cavity or grill pan. This can cause overheating, buckling and cracking of the enamel surfaces.

GETTING THE BEST RESULTS

- Minimize opening and closing the oven door during operation.
- Use the rack position recommended by the recipe and fine-tune with personal experience.
- Use the bakeware recommended in the recipe.
- Store the broiler pan(s) outside the oven. An extra pan without food will impact browning and cooking.
- For tender, golden brown crusts, use light non-stick/anodized or shiny metal pans.
- For brown crisp crusts, use dark non-stick/anodized or dark, dull metal pans or glass bakeware. These may require lowering the bake temperature 25°F (14°C).
- Allow at least 1" (25.4 mm) of space between

the pans and the oven walls so heat can circulate around each pan.

- To keep the oven as clean as possible, cook meat on a pan and not directly on the racks.
- Cooking will continue with residual heat. remove the dish from the oven immediately to avoid overcooking

OVEN COOKING RECOMMENDATIONS

Food	Pan size	Control temperature setting	Total suggested cooking time
Cookies	12"x15" Cookie Sheet	375°F	8 to 12 minutes
Layer Cakes	8" or 9" Round	350°F	25 to 35 minutes
Sheet Cakes	9"x13" Pan	350°F	30 to 40 minutes
Bunt Cakes	12 Cup	325°F	60 to 75 minutes
Brownies or Bar Cookies	9"x9" Pan	325°F	20 to 25 minutes
Biscuits	12"x15" Cookie Sheet	425°F or Package Directions	10 to 15 minutes
Quick Bread	8"x4" Loaf Pan	350°F	55 to 70 minutes
Muffins	12 cup Muffin Pan	425°F	14 to 19 minutes
Fruit Pies	9" Diameter	425°F	35 to 45 minutes
Fruit Cobblers	9"x9" Pan	400°F	25 to 30 minutes
Yeast Bread, Loaves	8"x4" Loaf Pan	375°F	25 to 30 minutes
Dinner Rolls	9"x13" Pan	400°F	12 to 18 minutes
Cinnamon Rolls	9"x13" Pan	375°F	25 to 30 minutes
Yeast Cotter and Cake	12"x15" Cookie Sheet	400°F	20 to 30 minutes

BROILING RECOMMENDATION

Food item	Control temperature setting selector	Approximate cooking time	Special instructions and tips
BEEF Ground Beef Patties, ½" thick	500°F fixed temperature setting	15 to 20 minutes	Broil until no pink in center
T-Bone Steak	500°F fixed temperature setting	12 to 20 minutes	Time depends on rareness of steak
Flank Steak	500°F fixed temperature setting	12 to 20 minutes	Rare to Medium Rare
Eye of Round Roast	325°F	20 to 25 min/lb	Small roasts take more minutes per pound; reduce time by using Convection Bake
PORK Loin Roast	325°F	20 to 25 min/lb	Cook until juices are clear
POULTRY Boneless Skinless Chicken Breasts	500°F fixed temperature setting	20 to 25 minutes	Cook until juices are clear
Chicken Thighs	500°F fixed temperature setting	25 to 30 minutes	Remove skin; Cook until juices are clear
Half Chickens	500°F fixed temperature setting	30 to 45 minutes	Turn with tongs; Cook until juices are clear
Roast Chicken	350°F	75 to 90 minutes	Do not stuff; reduce time by using Convection Bake
Turkey	325°F	20 to 25 min/lb	Do not stuff; reduce time by using Convection Bake

TROUBLESHOOTING COMMON PROBLEMS WITH OVEN COOKING

Problems	Cause	Remedy
Cakes burned on the sides or not done in center	Oven too hot Wrong pan size	Reduce temperature Use recommended pan size
Cakes crack on top	Batter too thick Oven too hot Wrong pan size	Follow recipe or add liquid Reduce temperature Use recommended pan size
Food too brown on bottom	Oven door opened too often Incorrect rack position Wrong bake setting	Use door window to check food Use recommended rack position Adjust to conventional or convection setting as needed
Food too brown on top	Incorrect rack position Oven not preheated	Use recommended rack position Allow oven to preheat
Cookies too flat	Hot cookie sheet	Allow sheet to cool between batches
Pies burned around edges	Oven too hot Oven not preheated	Reduce temperature Allow oven to preheat
Pies too light on top	Oven not hot enough Oven not preheated	Increase temperature Allow oven to preheat

OVEN TEMPERATURE INDICATOR

The range is equipped with a device to indicate the temperature in the middle of the oven. This lets you check the temperature inside the oven and adjust food cooking temperatures more accurately.

When the oven is turned on, the heating elements will start working at maximum and the thermometer dial will start to move towards the set temperature. Heat is optimally distributed inside the oven when the thermometer dial has stopped and pre-heating is finished. When the oven is turned off, the temperature on the thermometer will slowly drop until it reaches room temperature.

- *the gauge is for reference only.*

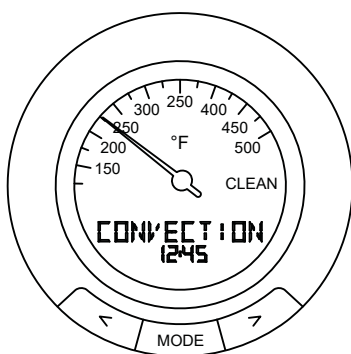

The Gauge is equipped with a digital interface that show the selected functions and manage the cooking time.

Set the gauge:

1. Press MODE.
2. Use the "<" and ">" buttons to select SET-UP
3. Press MODE.
4. Press the "<" and ">" buttons to select desired functions: language, 12h/24h, time, volume, showroom.
 - Language press "<" and ">" buttons to select desired language and press MODE to confirm
 - 12h/24h press "<" and ">" buttons to select desired clock indication and press MODE to confirm
 - Time press "<" and ">" buttons to select desired time (keep on press the button to fast forwarding) and press MODE to confirm
 - volume press "<" and ">" buttons to select desired volume control and press MODE to confirm
 - showroom do not use this function, is only for retailer

End/delay mode:

1. Press MODE.
2. Use the "<" and ">" buttons to select DELAY/END
3. Press MODE.
4. Press the "<" and ">" buttons to select the desired cooking time and press MODE
5. after 3 seconds will appear the end of cooking time, press M to start cooking, press < or > buttons to set a different end of cooking time (in this function the set time is the end of cooking) than press MODE to confirm.
6. set function and temperature with the knobs.
7. If the delay start is settled the display will show the cooking start time otherwise the oven will switch on
8. Once the set end of cooking time is finished, a sound will be heard and the oven automatically switches off.

Note: to change selected time restart from point 1.

Timer:

1. Press MODE.
2. Use the "<" and ">" buttons to select TIMER
3. Press MODE.
4. Press the "<" and ">" buttons to select the desired time and press MODE
5. The countdown start immediately and the display will show the remaining time
8. Once the set time is finished, a sound will be heard

Note: to change settled time restart from point 1. This function is only a minute minder and does not stop the cooking process.

Meat probe

The meat probe allows you more control over how your foods are cooked by automatically disabling the specified cooking mode when a dish's desired temperature, defined by the cook, has been reached. The probe expresses the current temperature of the meat as it cooks.

Programming the meat probe

1. Insert the food probe in the item to be cooked.

For best results, insert the probe as close as possible to the center of the item and make sure it is not in contact with bones or fat. Improper placement of the probe could shut the oven off too early and result in uncooked food. With poultry, make sure the probe does not rest in a cavity.
- 6 set function and temperature with the knobs.
2. Press MODE.
3. Use the "<" and ">" buttons to select MEAT PROBE

4. Press MODE.
5. Press the "<" and ">" buttons to select the desired cooking temperature and press MODE
6. Insert the items to be cooked on the oven then connect the probe jack to the port located in the upper left side of the oven cavity.
7. The display will show the current temperature of the meat and the selected temperature.
8. when the temperature selected will be reached a tone will be heard and the oven automatically switches off.

Note:

Once a time function is settle the other time functions are not available.

According to the recipe the oven can be pre-heat before use any time functions.

SELF-CLEANING

WARNING:

Children should not be left alone or unattended in an area where appliances are in use.

- During the Self-Clean cycle, exterior surfaces may become hotter than usual. Parts of the appliance may become potentially harmful to children, and to persons who lack adult knowledge of appliances and lack adult reactions to potentially harmful conditions.

Keep these individuals away during self-clean and while the appliance is in use.

- The elimination of soil during self-cleaning may facilitate the emission of small amounts of chemicals or other substances that may be harmful upon sufficient exposure. To minimize exposure to these

substances, provide good ventilation with an open window, or use a ventilation fan or hood.

- Keep pet birds out of the kitchen or other rooms where kitchen fumes could reach them. During selfclean, fumes are released that may be harmful to birds.

Electric oven

When set to the CLEAN mode, the oven reaches a high temperature of approximately 840°F/450°C that burns off all food residues from the inside of the oven.

When the oven is set for CLEAN, the cooktop burners may be used.

It is common to see smoke and/or flames during the clean cycle, depending on the content and amount of greasy residues in the oven. If the flame persists, turn off the oven and allow it to cool before opening the door and wipe off the excessive residues.

At the end of the CLEAN cycle, some grey ash or burned residue may remain inside the oven. This is a mineral deposit that does not burn or melt. The amount of ash depends on how heavily soiled the oven was before it was cleaned. It is easily removed, when the oven is cold, using a damp paper towel, sponge, or cloth.

Wipe off any smoke residue that remains on the front frame with a cleaning product suitable for oven cavity cleaning. If stains remain, use a mild liquid cleaner. The amount of smoke stain is directly related to the amount of food residues in the oven cavity before the start of the self-cleaning cycle.

Before Self Cleaning the Oven

Wipe out large spillages, grease and any loose soil that can be easily removed. Remove any soil that is outside the door seal area. This appliance is designed to clean the oven interior and the portion of the door that faces the oven cavity. The outer edges of the door and the oven cavity are not in the cleaning zone. Wipe this area clean before starting the self-cleaning cycle.

Remove all utensils and racks.

Make sure the light bulbs and glass covers are in place.

Turn on the ventilator hood above the range and leave it on until the self-clean cycle is completed (red indicator light turns off).

Remove racks

- 1 Locate the two hooks at the bottom of the rack and gently pull down at the same time the two hooks.
 - 2 Pull the rack away from the oven side and remove pulling up the upper hooks of the racks from the side of the oven.
 - 3 Remove the rack from the oven.
- Insert the probe closing cap into the port located in the upper left side of the oven cavity.

Door Lock

When the CLEAN cycle starts, the automatic door lock cycle begins. Check the door to confirm that it is locked. You can stop the self-cleaning cycle by turning the function selector to the OFF position. NOTE: make sure that the oven door is locked at the beginning of the self-cleaning cycle.

To Set/Start Self-Clean cycle

1. Check that the oven cavity is completely empty and the oven door correctly closed.
2. Turn the function control knob to CLEAN.
3. Turn the temperature control knob to CLEAN.

After these 3 steps the cooling fans will activate, the oven door will lock automatically after 60 seconds and both the pre-heating and clean light indicators will turn on.

As soon as clean light turns on check to ensure that the oven door is correctly locked.

At the End of the Self-Clean cycle

The self-cleaning cycle lasts approximately 2-2 ¼ hours; 30-40 minutes for pre-heating the oven (pre-heating and clean light both on), 60 minutes for actual cleaning (heating and clean light both on), 30-35 minutes for cool-down (only clean light on).

When the CLEAN light is turned off the oven door is unlocked. This will happen when the oven tem-

perature drops below 460-500°F/240-260°C approximately.

At the end of the cycle turn both the oven mode selectors and the temperature to the OFF position.

CAUTION

The interior of the oven will still be at baking temperatures when the automatic lock cycles to its open position and the oven door can be opened.

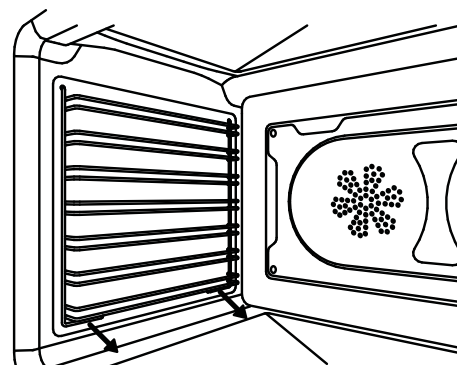

1

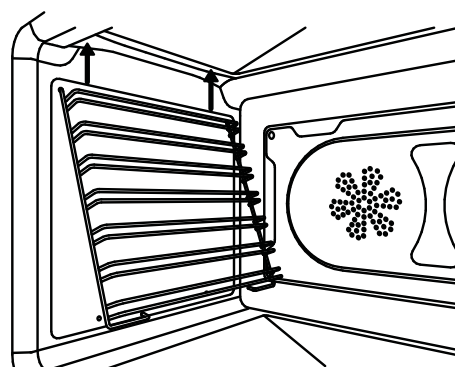

2

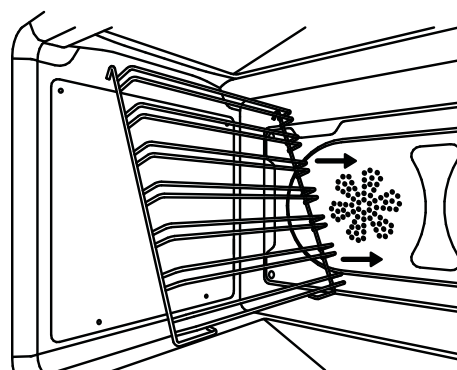

3

TELESCOPIC GLIDES

The telescopic glides fit any shelf level and work with the wire shelves provided as standard equipment.

Fitting the glides

- Locate the two spring clips at the front and back of the glides.
- Locate the pin on the glide that indicates the back.
- Choose the right level and position the telescopic glide near the upper wire.
- Gently insert the front spring clip on the glide.
- Insert the rear spring clip on the glide.
- Pull and push each glide to ensure the correct installation and smooth operation.
- Extract both glides to the fully extended position and place the shelf over them, making sure it's accurately placed between the rear pin and the front pin.

Removing the glides

- 1 - Locate the two spring clips at the front and back of the glide.
- 2 - Gently pull down the front spring clip.
- 3 - Pull the glide away from the oven side - be careful not to strain the clip.
- 4 - Repeat steps 2 - 3 on rear spring clip to remove glide.

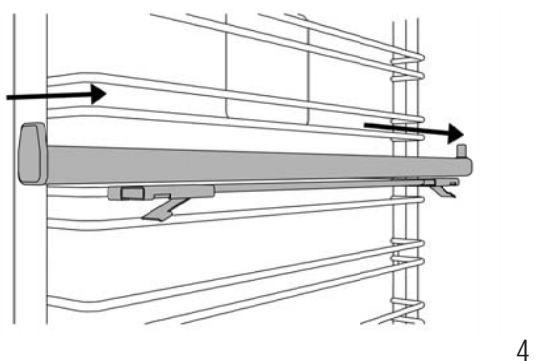
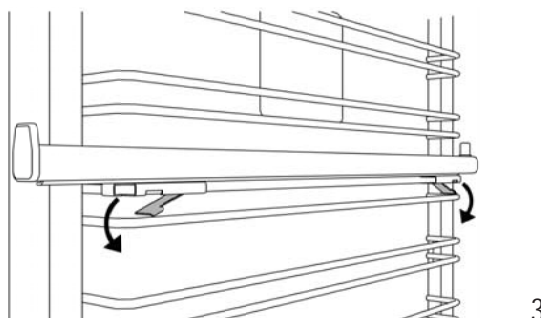
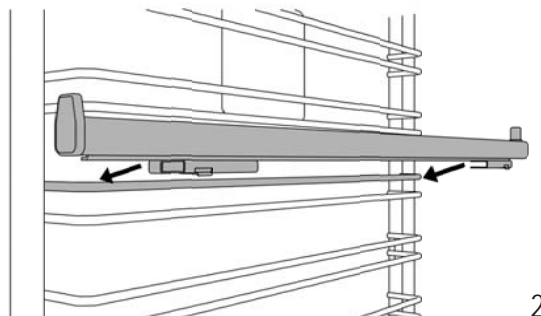
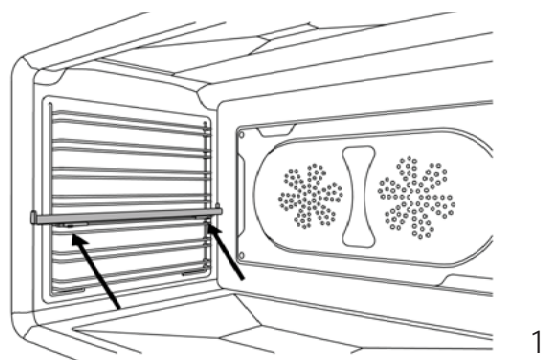

KEEPING YOUR BERTAZZONI CLEAN

Burn hazard

Make sure the heating elements are turned off and allowed to cool completely before any cleaning and/or maintenance operation.

Things to avoid:

- Do not use a steam cleaner to clean the range: the steam could reach electrical components and cause a short.
- Do not spray liquids such as cleaning agents into the openings on the bottom and top of the oven cavity.
- All surfaces can discolor or be damaged if unsuitable cleaning agents are used. The front of the oven, in particular, will be damaged by oven cleaners and descalers. All surfaces are susceptible to scratching. Scratches on glass surfaces may cause a breakage. Immediately remove any residues by using suitable cleaning products.
- The heating elements in the oven do not require cleaning. The elements burn off any residue when the oven is in use.

Cleaning stainless steel

All stainless steel parts should be wiped with hot water and soap solution at the end of each cycle. Wipe up spills and boilovers immediately. Use suitable, non-abrasive stainless cleaning products when water and soap solution will not do the job. *DO NOT use steel wool, abrasive cloths, cleaners, or powders.* If necessary, scrape stainless steel to remove encrusted materials, soak the area with hot towels to soften the residue, then use a wooden or nylon spatula or scraper. *DO NOT use a metal knife, spatula, or any other metal tool to scrape stainless steel.* DO NOT permit citrus or tomato juice to remain on stainless steel surface, as citric acid will permanently discolor stainless steel.

Cleaning painted surfaces

Clean with a soft cloth, warm water and non-abrasive dishwashing liquid. Whilst still damp, polish dry with a clean soft cloth.

Cleaning glass surfaces

Clean with cleaning detergent and warm water. Glass cleaner can be used to remove fingerprints. If using glass cleaner containing ammonia, make sure that it does not drip on exterior door surface.

Cleaning the broiler pan

Clean with detergent and hot water. For stubborn spots, use a soap-filled steel wool pad.

The porcelain enamel finish is acid resistant, but not acid proof. Acidic foods, such as citrus juices, tomatoes, rhubarb, vinegar, alcohol or milk, should be wiped up and not allowed to bake onto the porcelain during the next use.

Cleaning the induction cooktop

Allow the glass to cool down until the residual heat indicator is off before cleaning. Never use scouring powders or paste, metal scourers, oven cleaners or any abrasive cleaning products on the hotplate. Clean spillovers before using the cooktop again.

For light cleaning, wipe with a soft cloth, warm water and dishwashing liquid. For a streak free finish, polish dry with a microfibre cloth. For more stubborn marks and to condition the surface, use a good quality cooktop cleaner/conditioner, following the manufacturer's instructions. For spillages with high sugar content such as jam, or the accidental melting of plastic or alloy materials, turn off the heating zone and remove the spillage immediately.

Use caution because the heating area maybe very hot.

Cleaning the oven cavity

- Always allow the oven interior to cool before cleaning.
- Do not allow vinegar, wine, coffee, milk, salt water or fruit juices to remain in contact with enamelled surfaces for prolonged periods as they may stain or discolour the surface.
- Never use sharp utensils to remove stains as this could scratch the surface.
- Never use steam cleaners on the oven interiors as steam may damage electronic parts.
- For light cleaning, wipe with a soft cloth, using warm water and washing up liquid. For heavier residues, use a cream cleaner and a nylon scourer.
- Oven cleaning products can be used according to the manufacturer's directions but care should be taken that they do not come in contact with any stainless steel, chrome, painted or alloy parts of the range or the door seals and elements.

Cleaning oven racks and supports

Clean with detergent and hot water. Stubborn spots can be scoured with a soap-filled steel wool pad.

SIMPLE MAINTENANCE

These simple tasks can be performed by the owner. For any other maintenance task, we recommend employing a trained service technician. Please call our toll free line to identify service technicians in your area:

ENGLISH 866 905 0010

if located in the US, BC, B, Sk and MB

FRANCAIS 800 561 7265

if located in ON, QC, PE, NU, NS, NL, NB

REPLACING OVEN LIGHTS

Warning! Electric shock hazard!

Disconnect the electric power at the main fuse or circuit breaker before replacing bulb. DO NOT touch bulb with bare hands. Clean off any signs of oil from the bulb and handle with a soft cloth.

Side oven light

Bulb type: halogen G9 120 V, 40 W

- Make sure the heating elements are turned off and allowed to cool completely. Disconnect the appliance from the power supply. Remove the oven rack if it interferes with the light housing.
- Slide the tip of a flat screw driver between the glass cover and the lamp housing. Gently twist the screw driver tip to loosen the glass lens cover, holding it in place with your fingers to prevent it from falling and breaking.
- Remove the glass lens cover and then remove the halogen bulb.
- Place a new halogen bulb in its slot. DO NOT touch bulb with bare hands.
- Press the glass cover back into place and replace the oven rack.
- Reconnect the oven to the electrical supply.

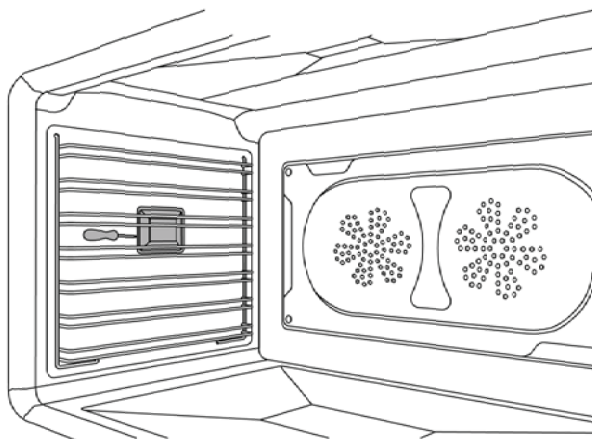

1

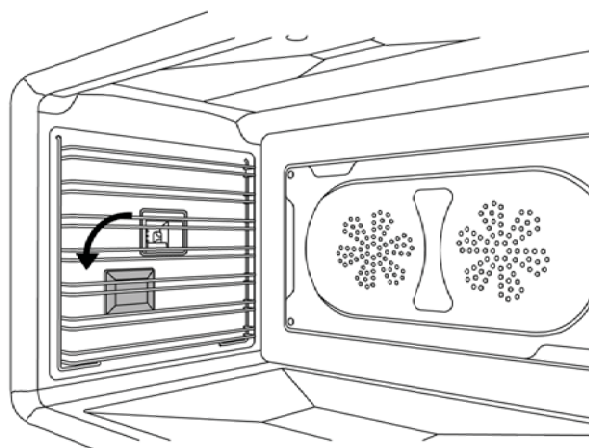

2

Top oven light

Bulb type: halogen G9 120 V, 40 W

- Make sure the heating elements are turned off and allowed to cool completely. Disconnect the appliance from the power supply.
- Unscrew the glass cover and remove the halogen bulb.
- Place a new halogen bulb in its slot. DO NOT touch bulb with bare hands
- Screw the glass cover back in place.
- Reconnect the oven to the electrical supply.

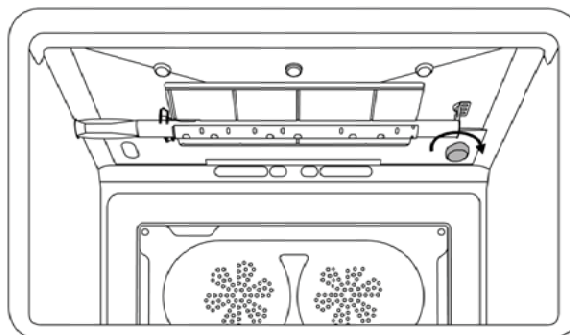

1

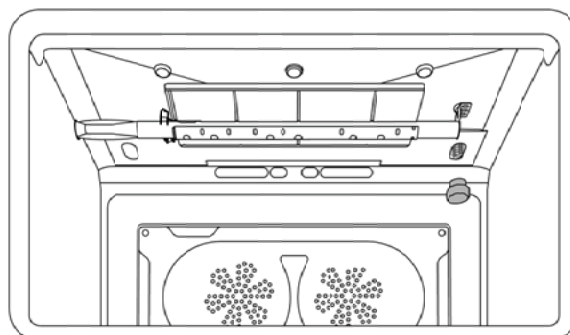

2

CLEANING INSIDE GLASS DOOR

The inner glass door panels can be easily removed for cleaning. It is not necessary to remove the door in order to clean the glass panes. The glass can be cleaned in situ or removed.

- Open the oven door to its fully extended position.
- Flip down hinge clip on each hinge to secure the door in an open position. A screwdriver may be necessary to carefully pry the clip back.
- Slide the clips towards the centre of the door.
- Holding the glass pane, lift slightly and pull towards the oven to release the glass panel.

Note: when glass is being removed, which side faces into the oven. Incorrect replacement may cause the glass to shatter or be damaged.

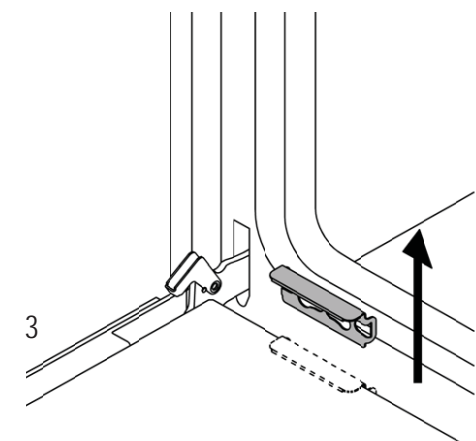
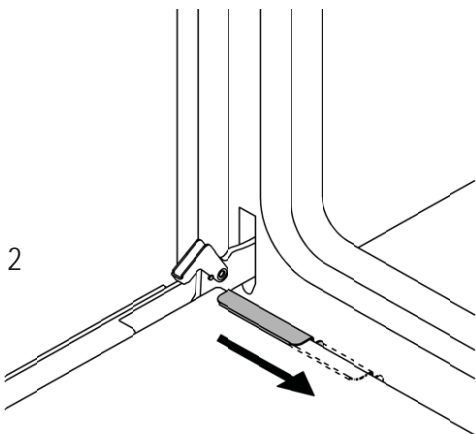
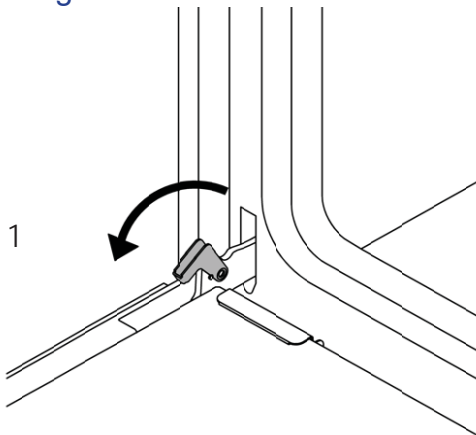
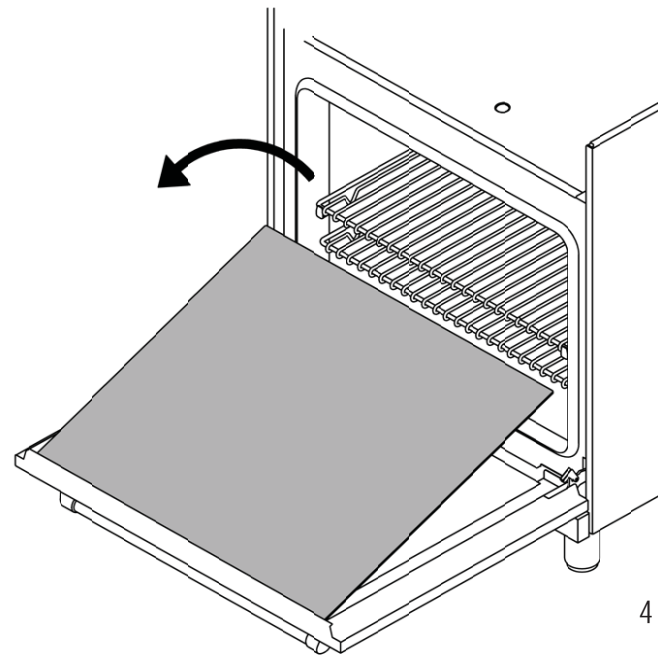

Warning!

If the hinges are not locked properly and the inner glass is removed, the door can close by itself causing personal injuries.

TROUBLESHOOTING

Here are answer to common problems you may experience. You are also welcome to call our toll free Customer Service line to troubleshoot any issue with your Bertazzoni:

ENGLISH 866 905 0010

if located in the US, BC, B, Sk and MB

FRANCAIS 800 561 7265

if located in ON, QC, PE, NU, NS, NL, NB

The oven will not operate

Is there power to the range? Check the switch fuse or circuit breaker.

The oven does not heat

Check that the showroom function is not activated.

The control knob are getting too hot

Are you cooking with the oven door open? Keep the oven door shut when not in use or when grilling/broiling.

A control knob is loose on its shaft

The knob retaining spring clip may have been damaged. Call our service department for advice and a replacement if necessary.

Food is cooking too quickly

Are you using a convection mode? When using a fan-assisted oven cooking mode, it is recommended to reduce the cooking temperature by 70°F compared to conventional cooking.

Food is not cooking evenly

Are you cooking large amount of food or are you using large bakeware? Air needs to circulate through the oven for even cooking. Remove the grill pan from the oven when not in use and always allow a gap on all four sides of dishes. You may need to turn your bakeware during the cooking cycle. Oversized baking sheets, roasting pans and cakeware will act as a baffle and prevent hot air from moving evenly around the cavity. Choose cooking equipment that allows a minimum of 1 inch (2,5 cm) space on all sides to allow the free movement of heat inside the cavity.

Grilling in the oven is slow

Have you selected the correct function?

Condensation forms in the oven

Have you pre-heated the oven?

Condensation is less likely to form when the oven or grill is pre-heated before use.

Smoke is generated in the oven

Have you selected the right cooking temperature? Are you cooking food with high fat? Do you rarely use the grill? Have you cooked fat under the grill? Does the oven interior need to be cleaned? Remember to reduce the oven temperature by 70°F if using a fan function with a recipe designed for conventional cooking. Use high-sided dishes to contain fats and splashes. Leave the grill on for a few minutes after grilling or roasting to burn off fat deposits from the oven roof. Oven surfaces should be cleaned regularly to prevent build-up of cooking residues.

Please kindly register on our web site www.bertazzoni.com to validate your new product warranty and help us to assist you better in case of any inconvenience.

TWO YEAR LIMITED WARRANTY

The warranties provided by Bertazzoni Spa in this statement apply exclusively to Bertazzoni appliances and accessories sold as new products to the original owner by a Bertazzoni authorized distributor, retailer, dealer or service center and installed in the United States and Canada. The warranties provided in this statement are not transferable and have validity from the date of installation.

Coverage information

Bertazzoni SpA will repair or replace any component part which fails or proves defective due to materials and/or workmanship within 2 years from the date of installation and under conditions of normal residential use. Repair or replacement will be free of charge, including labor at standard rates and shipping expenses. Repair service must be performed by a Bertazzoni Authorized Service Center during normal working hours.

Cosmetic warranty

Bertazzoni will cover parts showing cosmetic defects in material and workmanship for a period of thirty (30) days from date of installation of the unit. This coverage will include scratches, stains, surface imperfections on stainless steel, paint and porcelain, with the exclusion of slight differences in color due to materials and painting/enamelling technologies.

Exclusions are labor costs, B stock items, out-of-box appliances and display units.

How to obtain service

To obtain warranty service please contact Bertazzoni Customer Service at the numbers below and provide model number, serial number and date of purchase.

ENGLISH 866 905 0010

if located in the US, BC, B, Sk and MB

FRANCAIS 800 561 7265

if located in ON, QC, PE, NU, NS, NL, NB

Save proof of original purchase or of original installation to establish warranty period. Copy of the product serial tag is affixed to the back cover of the instruction manual.

What is not covered

The product used in any commercial application
Repair service provided by other than a Bertazzoni authorized service agency.
Damage or repair service to correct service pro-

vided by an unauthorized agency or the use of unauthorized parts.

Installation not in accordance with local electrical codes, gas codes or plumbing codes.

Defects or damage due to improper storage of the product.

Defects or damage or missing parts on products sold out of the original factory packaging or from displays.

Service calls or repairs to correct the installation of the product and/or related accessories.

Service calls to connect, convert or otherwise repair the electrical wiring and/or gas line to properly use the product.

Service calls to provide instructions on the use of a Bertazzoni product.

Repair service due to product usage in manner other than what is normal and customary for home use.

Replacement of wear and tear parts

Replacement of glasses and light bulbs if they are claimed to have failed later than 30 days after installation and in no case later than 4 months after date of purchase

Defects and damages arising from accident, alteration, misuse, abuse, improper installation.

Defects and damages arising from transportation of the product to the home of the owner.

Defects and damage arising from external forces beyond the control of Bertazzoni SpA such as fire, flood, earthquakes and other acts of God.

In case the product will be installed in a remote area, where certified trained technicians are not reasonably available, the customer will be responsible for the transportation costs for the delivery of the product to the nearest authorized service center or for the displacement costs of a certified trained technician.

Bertazzoni does not assume any responsibility for incidental or consequential damages.

Some states do not allow the exclusion or limitation of incidental or consequential damages, so the above limitation or exclusion may not apply to you. This warranty gives you specific legal rights and you may also have other rights which may vary from state to state or province to province.