

GLOBAL PROCUREMENT AND MARKETING LIMITED

LOW TV UNIT

Assembly instruction- Please keep for future reference

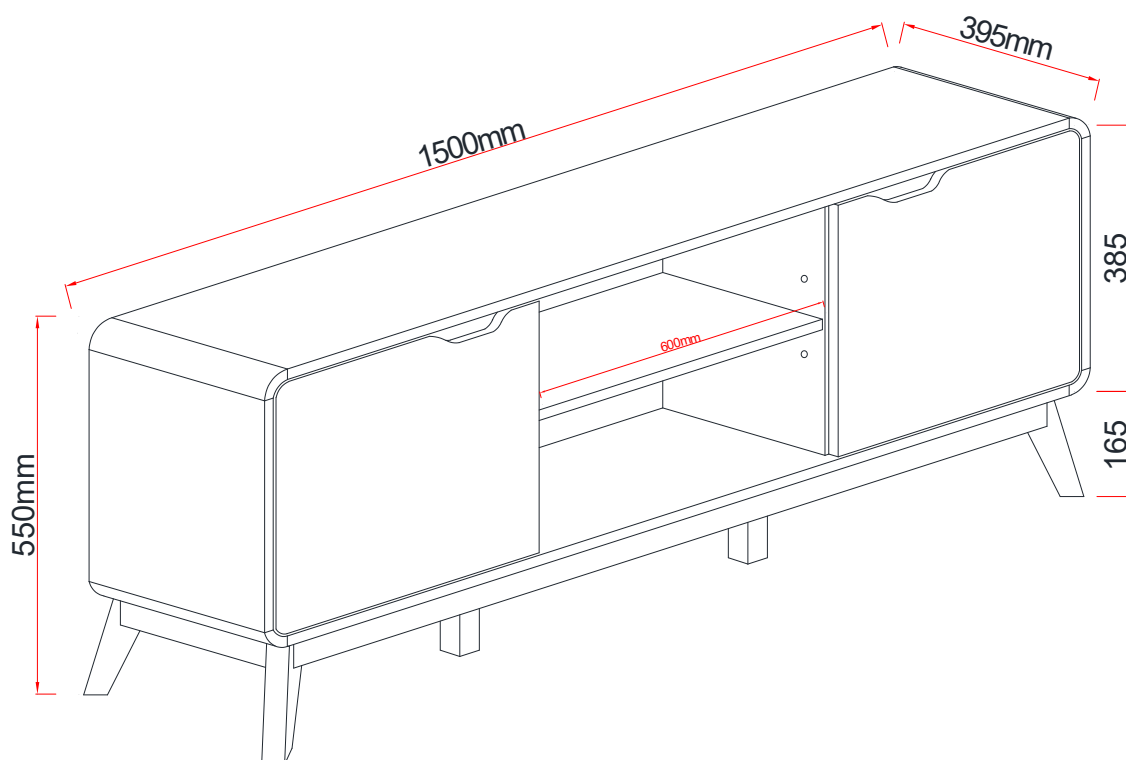

Dimensions	No. People	Assembly Time	
Width: 150cm	👤	35 mins (approx)	
Depth: 39.5cm			
Height: 55cm			

Important-Please read these instructions fully before starting assembly

If you need help or have damaged or missing parts, please **contact us**.

⚠ Safety and Care Advice

Important-Please read these instructions fully before starting assembly

- Check you have all the components and tools listed on pages 2,3 and 4.
- Remove all fittings from the plastic bags and separate them into their groups.
- Keep children and animals away from the work area, small parts could choke if swallowed.
- Make sure you have enough space to lay out the parts before starting.
- Do not stand or put weight on the product, this could cause damage.
- Assemble the item as close to its final position (in the same room) as possible.
- Assemble on a soft, level surface to avoid damaging the unit or your floor.
- We do not recommend the use of power drill/drivers for inserting screw, as this could damage the unit. only use hand screwdrivers.
- Dispose of all packaging carefully and responsibly.



Care and Maintenance

- Only clean using a damp cloth and mild detergent, do not use bleach or abrasive cleaners.
- From time to time check that there are no loose screws on this unit.
- This product should not be discarded with household waste. Take to your local authority waste disposal centre.

If you are unhappy with the product and wish to return it, please following the retailer's return procedure

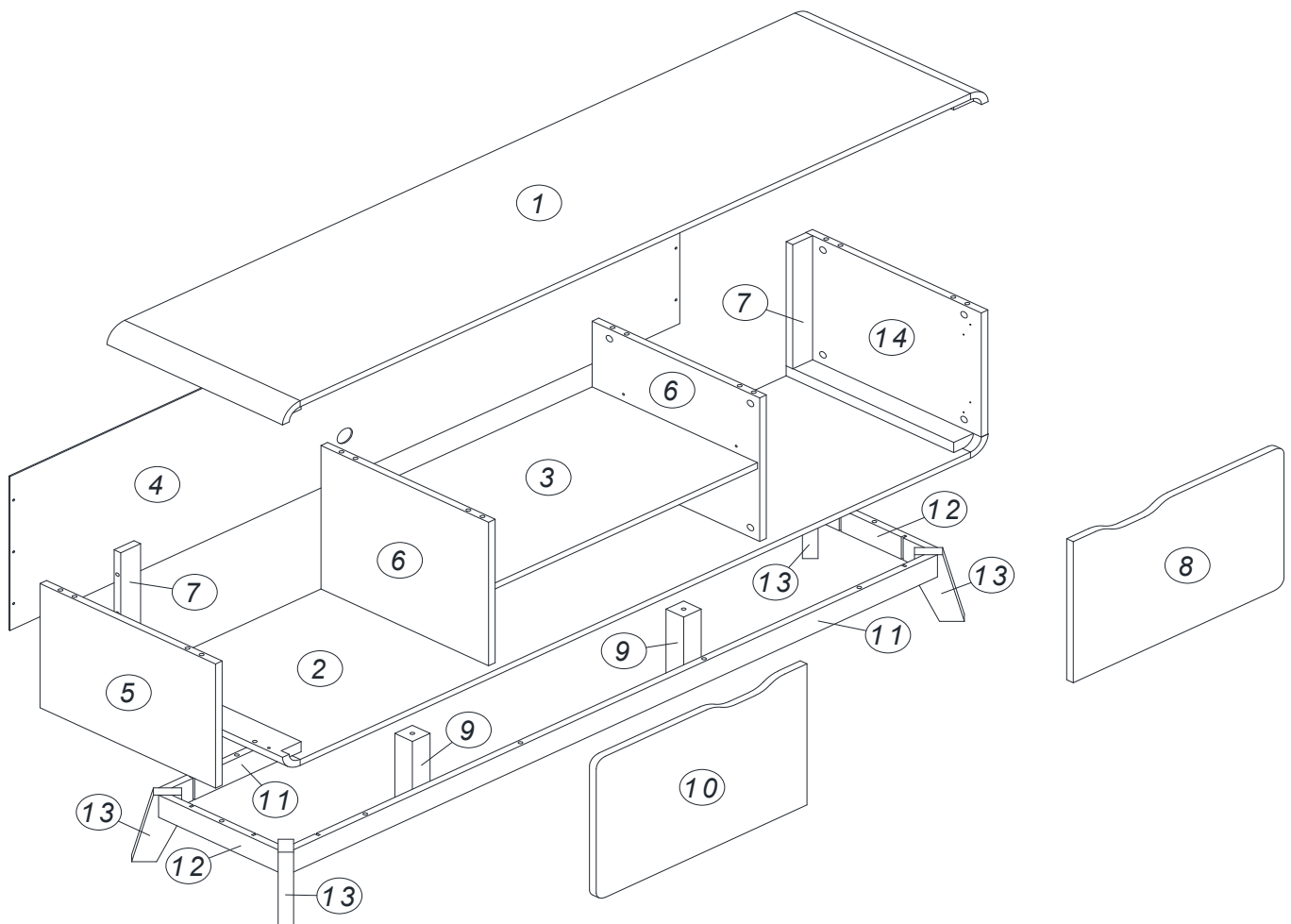









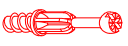





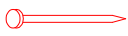

Components - Fixings

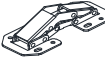
Please check that you have all the components listed below before constructing your item.

Note: The quantities below are the correct amount to complete the assembly. In some cases more fittings may be supplied than are required.

HARDWARE

(A1)  MINIFIX 16MM X 20	(A2)  MINICAM 16MM X 20	(A3)  MINI CAP X 16	(B)  WOOD DOWEL 8 X 30 MM X 18	(C)  ALLEN KEY X 1
(D)  PAN HEAD 3.5 X 16MM X 6	(E)  CSK M3.5 X 16 MM X 56	(F)  CSK M4 X 38 MM X 10	(G)  NAIL X 20	(H)  SHELF SUPPORT X 4
(I)  CLEAR BUMPER X2	(J)  90 DEGREE HINGE X 4	(K)  JCBC M6 X 35 MM X 2	(L)  JCBC M6 X 20 MM X 8	(M)  METAL CORNER X 4
(N)  NAIL LEG 5/8 X 6	(O)  WASHER X 8			

Tools Required (Not Provided)

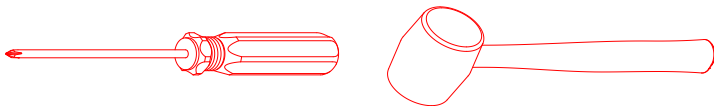

Ruler - Use this to measure your screws (mm)

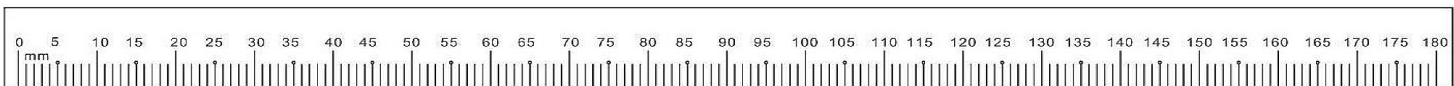

Important-Please read these instructions fully before starting assembly

If you need help or have damaged or missing parts, please **contact us**.

Assembly Instructions

Step 1

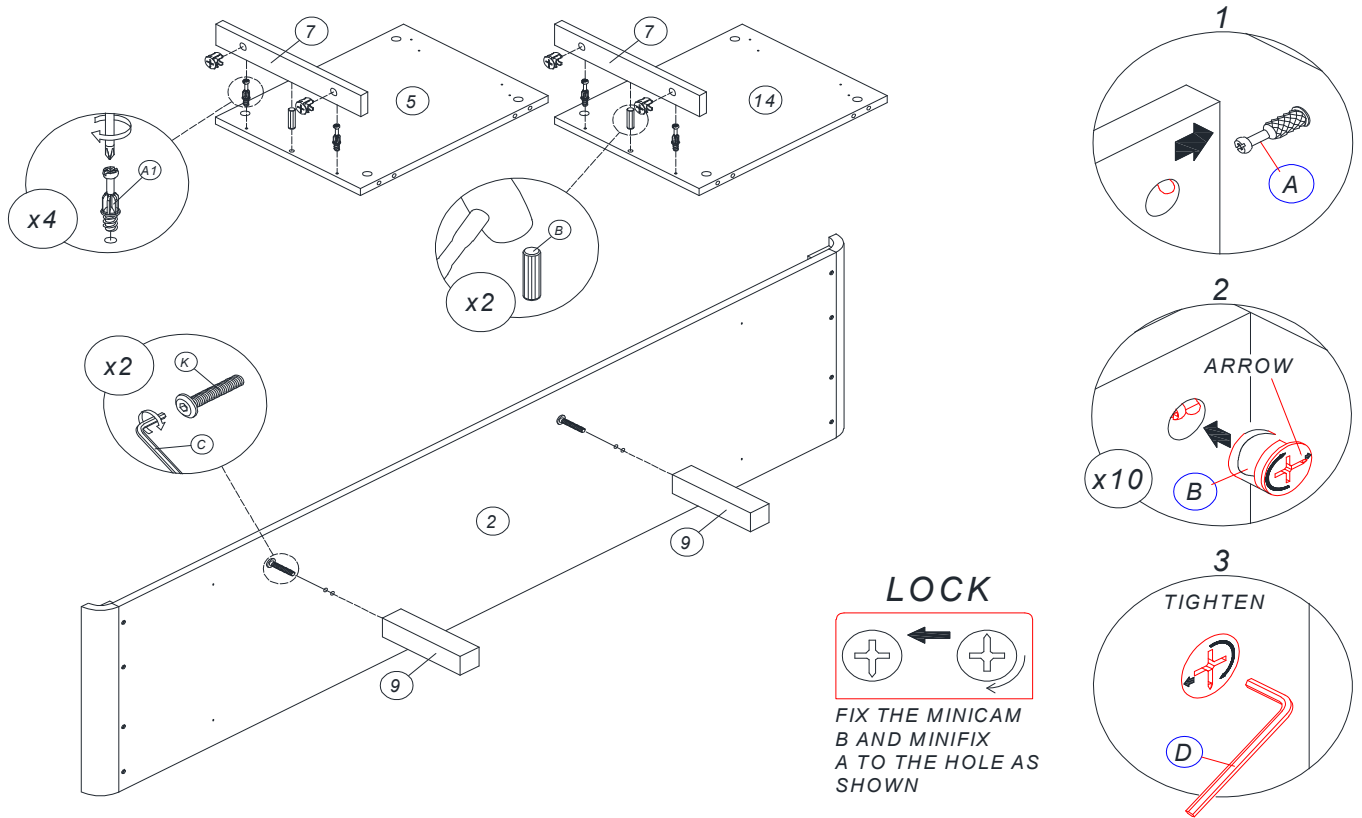

Step 2

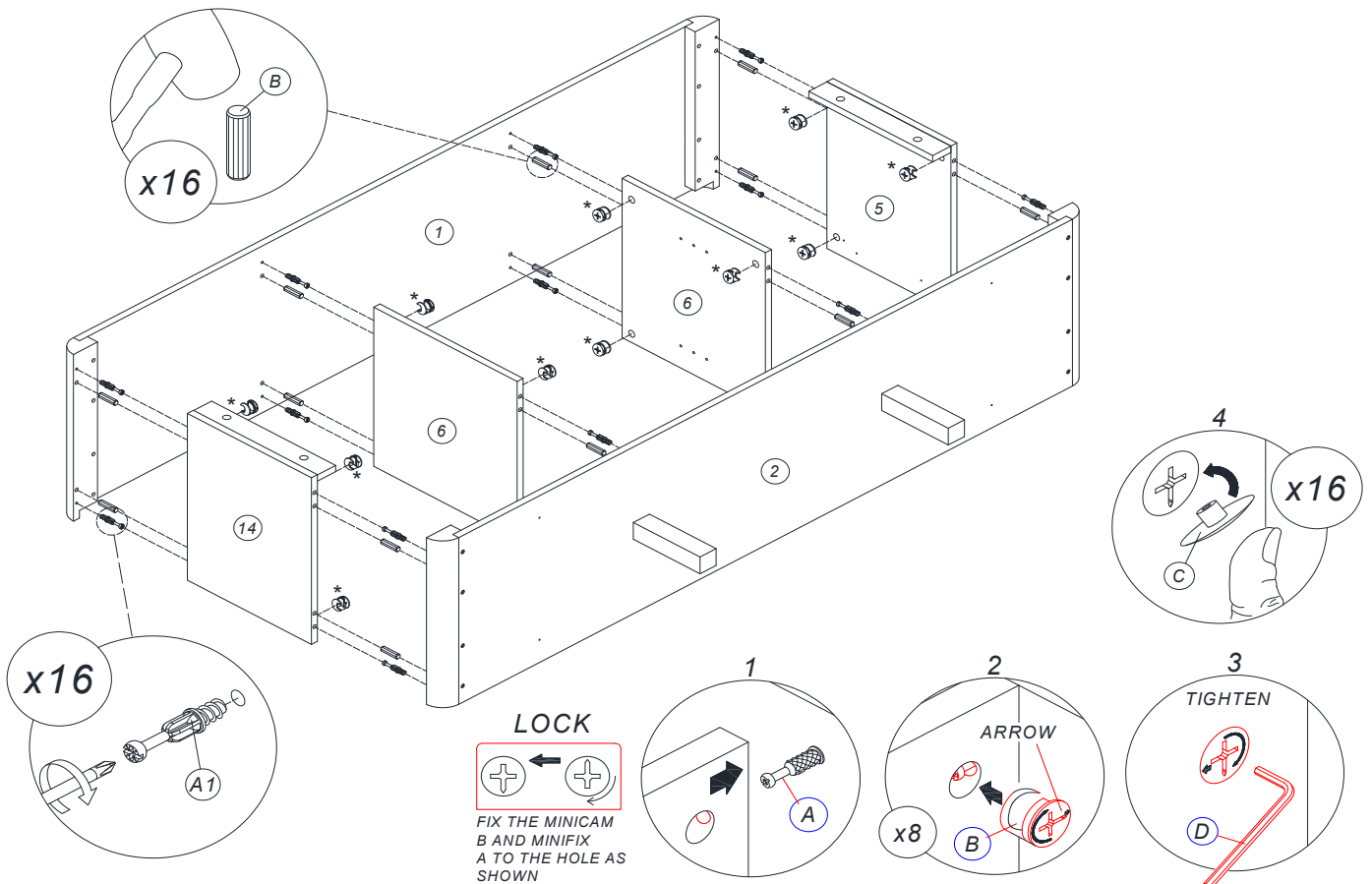

Step 3

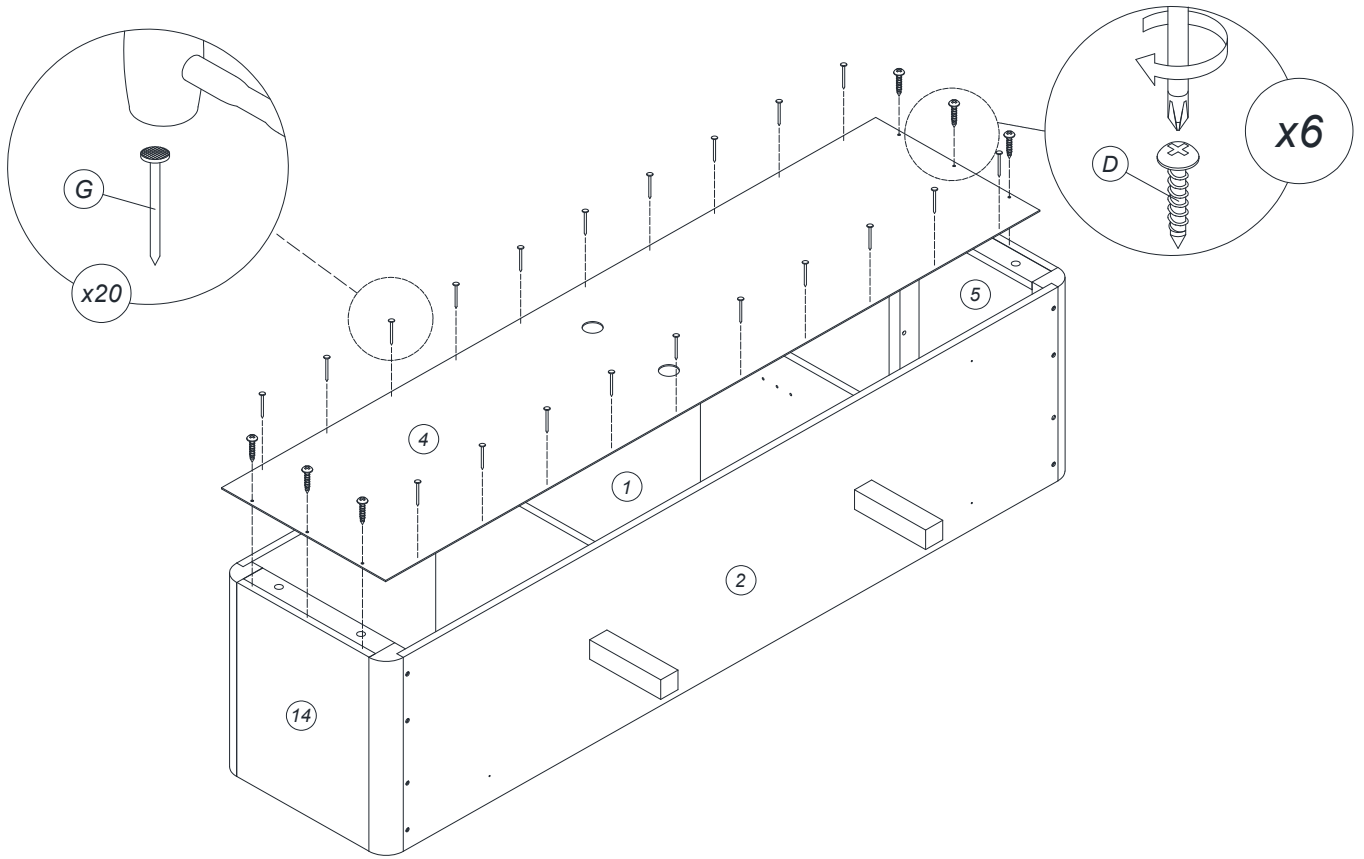

Step 4

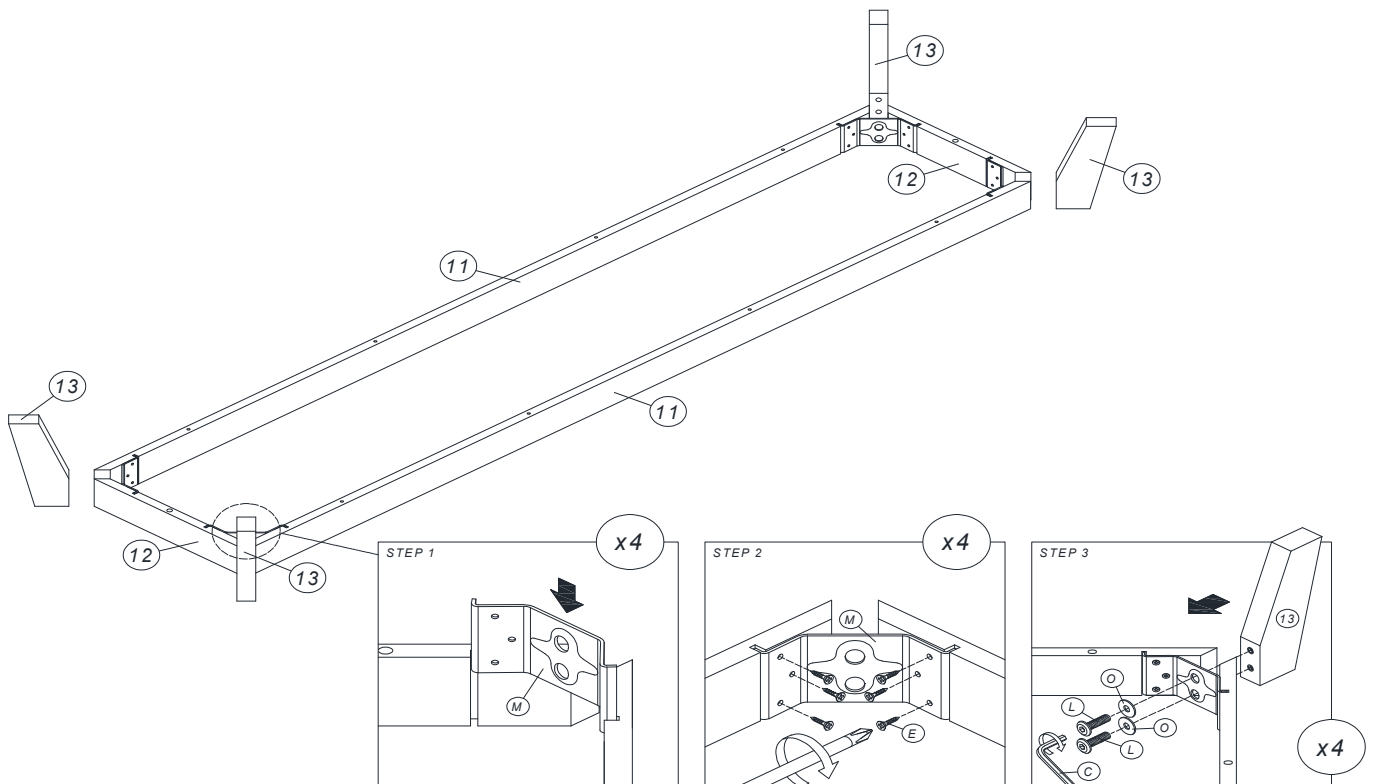

Step 5

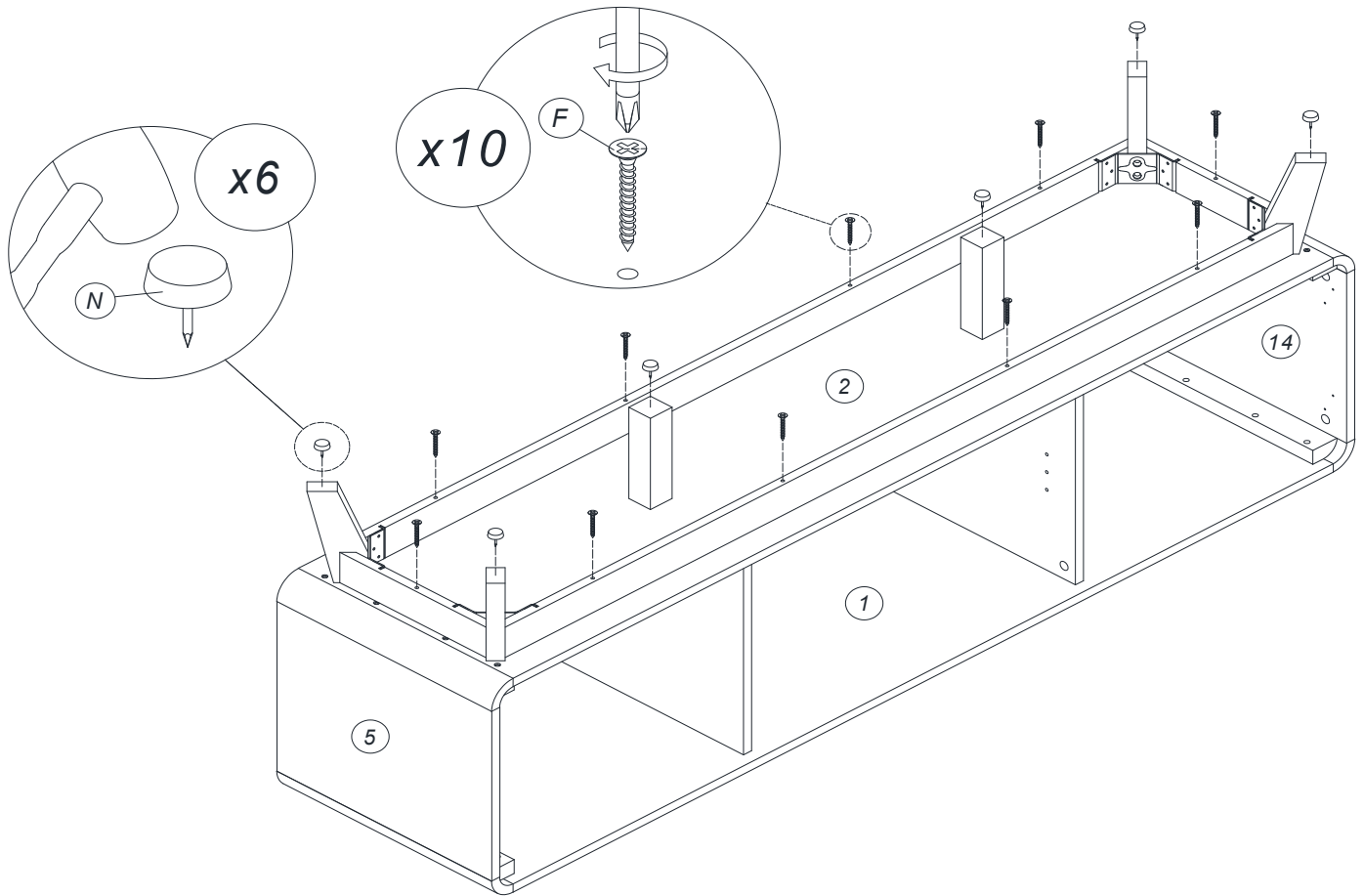

Step 6

