

User Manual

Teslin Stacking Chair

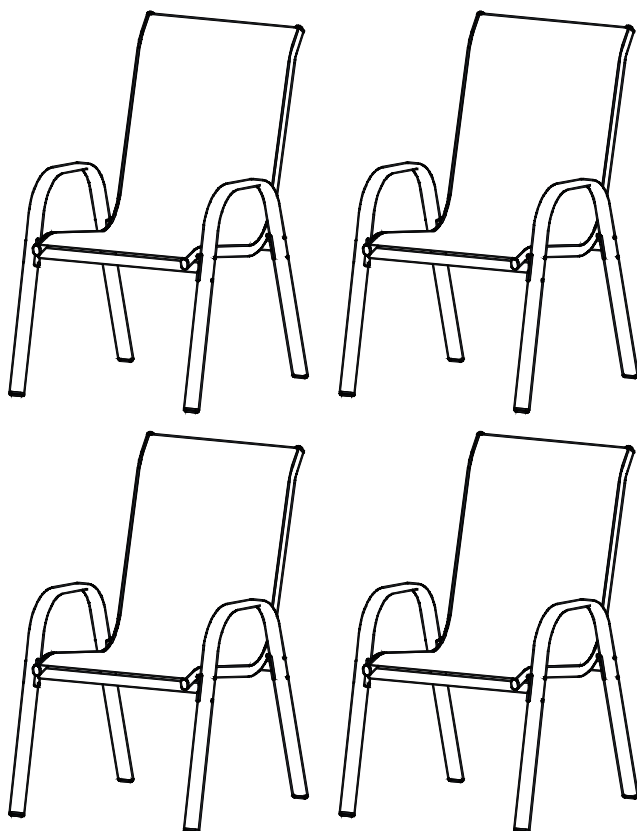

Model: YTC-301

Please read the instruction manual carefully and use it correctly according to the usage instructions.
Please keep the instruction manual properly for reference!

Contents

English	01~07
Deutsch	08~14
Français	15~21
Italiano	22~28
Español	29~35

Guide to Assemblinait!

WARNINGS FOR ASSEMBLY AND USE

The assembly must be carried out by 2 adults. Remove stickers and protective papers before assembly and use. Before proceeding with the assembly make sure that all components are present in the packaging.

Observe the general safety rules during assembly.

To properly assemble the item, carefully follow the assembly instructions attached here.

The item should be mounted on a solid, flat surface free of anything that could damage it. Mounting on an uneven surface such as concrete can cause instability and may result in bumps or scratches that could damage the item.

Before using the item, make sure it is well assembled.

It is not recommended that the product be shaken or subjected to excessive impact. Do not hit the surface with hard and/or sharp objects. The product is intended for home use.

MAINTENANCE WARNINGS

Keep the object away from heat sources. Do not use aggressive cleaning products for cleaning. Clean with a damp cloth and dry.

In order to keep the items and their metal parts in good condition, it is essential that it is not left out in the elements. The product should be stored in a clean and dry environment with any moisture removed with a dry towel before storage to prevent corrosion.

It is recommended that the tightness of the bolts should be checked periodically to ensure nothing has come loose. Always checking before the first use, after removing the item from storage.

Warnings and Cautions

Please retain this instruction for future usage and read carefully before assembly.

Make sure you have all the parts & hardware as item list shows.

2 adults are recommended to install your chair.

Do not discard any of the packaging until you have checked that you have all the parts and pack of fittings.

Check all bolts for tightness before use, and periodically check and tighten bolts ensure your chair works properly.

Some parts might have sharp edges/corners. Please follow basic safety precautions to reduce the risk of hurts.

Notes

- 1.Chemicals water might cause fading.
- 2.Cleaning and drying the chairs after it rains.
- 3.Cleaning and drying the chair in time if exposed to chemicals.
- 4.Please cover and store it if not in use.



**THIS ITEM CONTAINS SMALL PARTS WHICH CAN BE SWALLOWED BY CHILDREN.
PLEASE KEEP IT AWAY FROM CHILDREN UNDER 3 YEARS OLD AND PETS DURING INSTALLATION.**

READ AND SAVE THESE WARNINGS FOR FUTURE REFERENCES

A 4PCS	B 8PCS	C 8PCS	D 4PCS	E M6X55 16PCS	F M6X70 16PCS
G M6 64PCS	H 32PCS	J 32PCS	K M6 32PCS	L $\Phi 13 \times 5 \text{mm}$ 16PCS	 1PCS

NOTE: Legs B have been matched and tied together before leaving the factory. Therefore, to assemble a chair, disassemble a pair of legs B. Please do not mix all the legs together!

Have an issue? Let us help withal

READ AND SAVE THESE WARNINGS FOR FUTURE REFERENCES.
If you have any questions or requests, pls feel free to contact us.
We will try our best to help you.

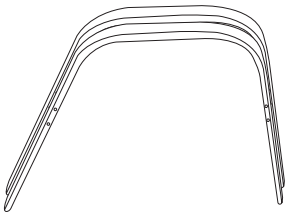

Compare two legs B to see if they are exactly the same.

1

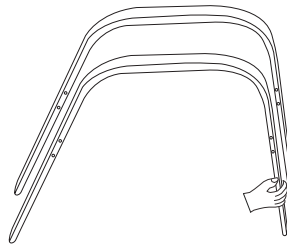

If it is different, gently press or pull the lower end of the leg with your hands.

2

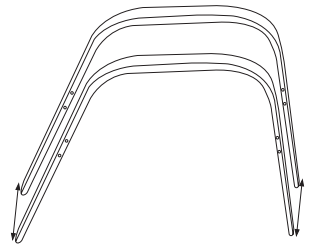

Make sure two B legs are exactly the same shape before installation.

3

1



Please pull the fabric into place before assembling if it retracts.

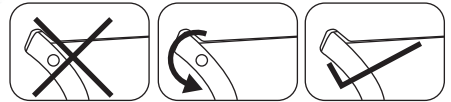
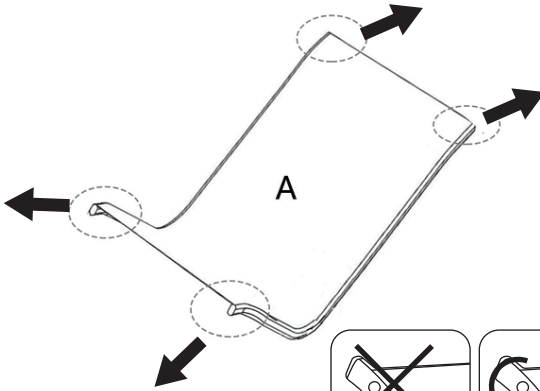

The screw holes on the side bars should face inwards, otherwise the backrest bar will not be installed correctly.

2

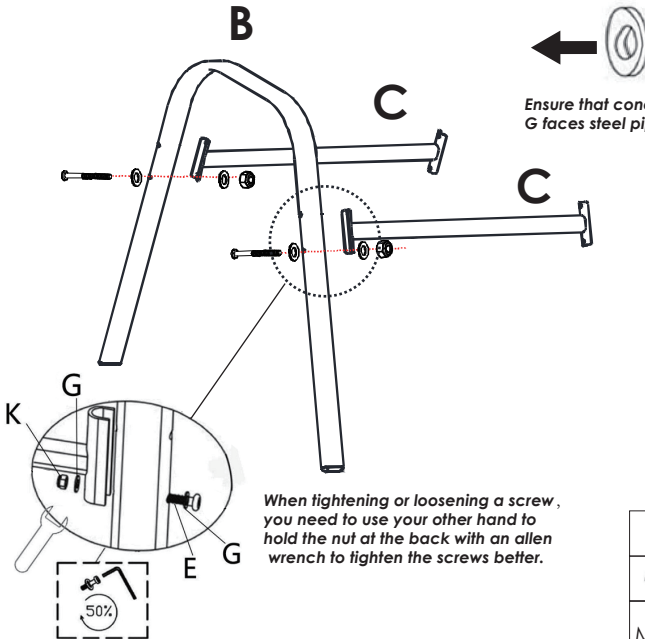

Ensure that concave surface of G faces steel pipe connection.

When tightening or loosening a screw, you need to use your other hand to hold the nut at the back with an allen wrench to tighten the screws better.

Temporarily tighten the screws to 50% and do not tighten them fully so that the subsequent screws can be better aligned with the screw holes.

	B x1
	C x2
	M6X55 E x2
	G x4
	M6 k x2

3

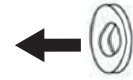
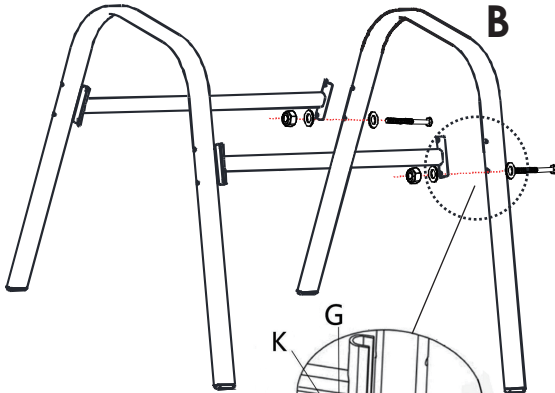

Ensure that concave surface of G faces steel pipe connection.

	B x1
	E x2
	G x4
	k x2

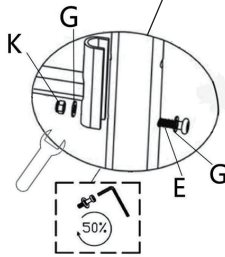

Temporarily tighten the screw to 50%, do not tighten completely.

4

You need to know this before step 5

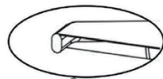

Slightly curved edge of accessory A is the top of the backrest.

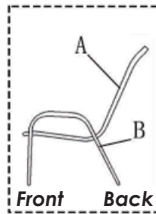
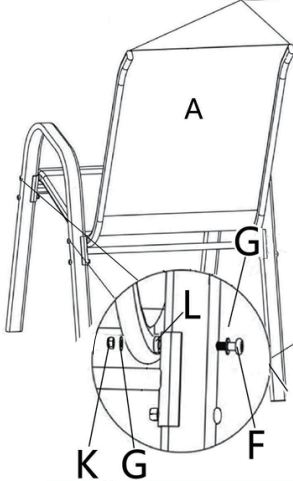

Front legs are angled almost perpendicular to the ground.



Tighten screws to 20%

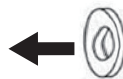

Ensure that concave surface of G faces steel pipe connection.

5



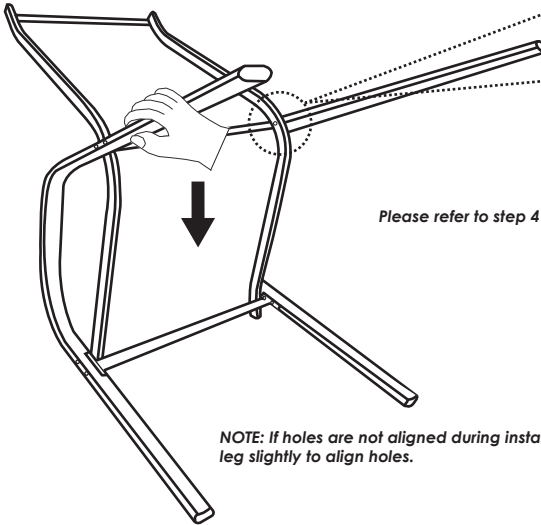

Install the screws for the back legs

You need to first lay the chair down with the back legs facing upwards and tighten the back leg screws by 20%.



Please refer to step 4 for the correct order of installing the screws.

NOTE: If holes are not aligned during installation, press the leg slightly to align holes.

	A x1
	F x2
	G x4
	L x2
	K x2

6



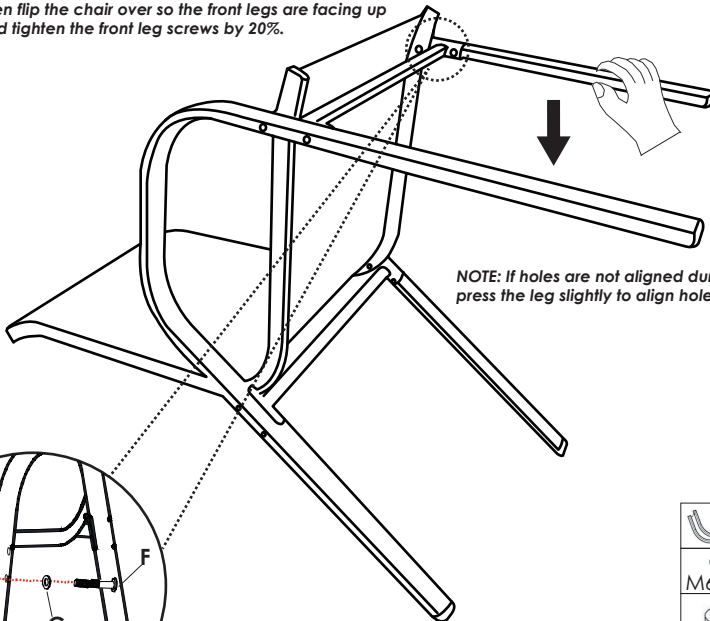

Install the screws for the front legs

Then flip the chair over so the front legs are facing up and tighten the front leg screws by 20%.



NOTE: If holes are not aligned during installation, press the leg slightly to align holes.

Please refer to step 4 for the correct order of installing the screws.

	A x1
	F x2
	G x4
	L x2
	K x2

7

When inserting the backrest rod, you need to rotate it first to shorten its length and gently pull the side rod for better insertion.

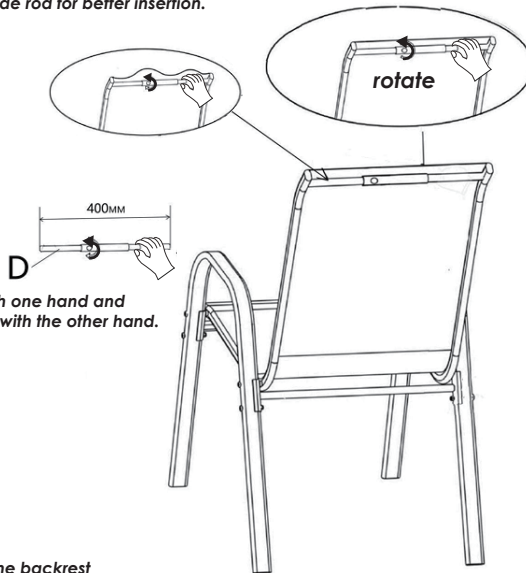

Hold one end of D with one hand and rotate the center of D with the other hand.

Adjust the length by rotating the backrest rod to fully spread the fabric.

8

Assemble on flat ground.

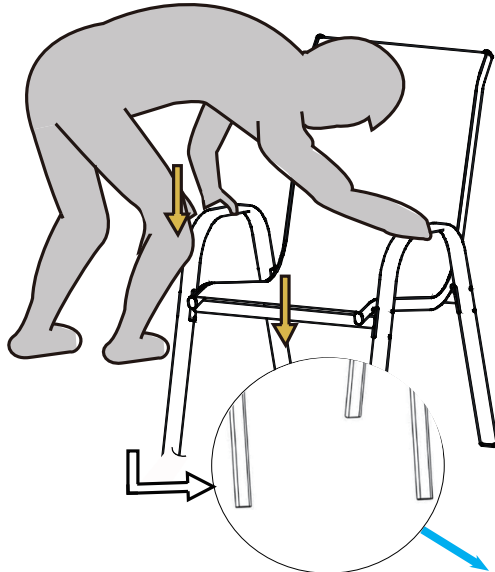

Make sure all 4 legs of chair are in full contact with the ground.

How to prevent chair from being uneven after installation?

1. Please place the chair on a flat ground for installation.
2. While tightening screws, continuously adjust the chair legs until they are stable.

9

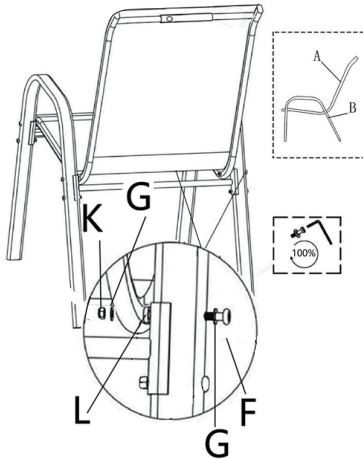

If chair is unstable after installation, slightly loosen all screws and fine-tune leg and frame position. Then retighten all screws.

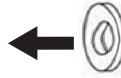

Ensure that concave surface of G faces steel pipe connection.

NOTE: If holes are not aligned during installation, please press the B leg slightly to align holes.

Tighten all screws completely.

	F x2
	G x4
	K x2
	L x2

10

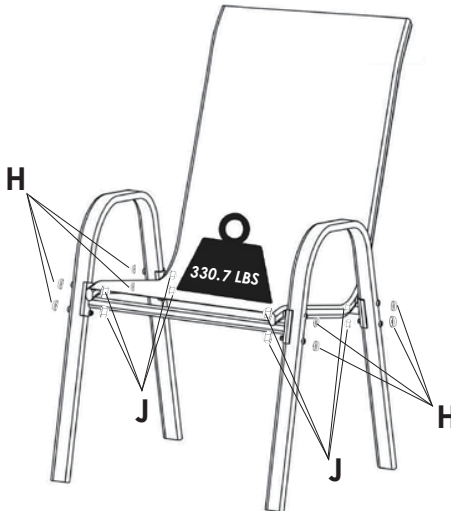

After tightening all screws, install the H and J plastic nuts.



Max load capacity: 330.7 LBS

	H x8
	J x8

Anleitung zur Montage!

HINWEISE ZUR MONTAGE UND VERWENDUNG

Die Montage muss von 2 Erwachsenen durchgeführt werden. Entfernen Sie vor der Montage und Verwendung Aufkleber und Schutzpapiere. Vergewissern Sie sich vor der Montage, dass alle Komponenten in der Verpackung vorhanden sind.

Beachten Sie die allgemeinen Sicherheitsregeln während der Montage. Um den Artikel ordnungsgemäß zusammenzubauen, befolgen Sie sorgfältig die hier beigefügten Montageanweisungen.

Der Artikel sollte auf einer festen, ebenen Oberfläche montiert werden, die frei von allem ist, was ihn beschädigen könnte.

Die Montage auf einer unebenen Oberfläche wie Beton kann zu Instabilität führen und zu Beulen oder Kratzern führen, die den Artikel beschädigen könnten.

Vergewissern Sie sich vor der Verwendung des Artikels, dass er gut zusammengebaut ist. Es wird nicht empfohlen, das Produkt zu schütteln oder übermäßigen Stößen auszusetzen. Schlagen Sie nicht mit harten und/oder scharfen Gegenständen auf die Oberfläche. Das Produkt ist für den Heimgebrauch bestimmt.

HINWEISE ZUR WARTUNG

Halten Sie den Artikel von Wärmequellen fern. Verwenden Sie zum Reinigen keine aggressiven Reinigungsmittel. Reinigen Sie ihn mit einem feuchten Tuch und trocknen Sie ihn ab.

Um die Artikel und ihre Metallteile in gutem Zustand zu halten, ist es wichtig, dass sie nicht den Elementen ausgesetzt werden. Das Produkt sollte in einer sauberen und trockenen Umgebung gelagert werden, wobei jegliche Feuchtigkeit vor der Lagerung mit einem trockenen Tuch entfernt werden sollte, um Korrosion zu vermeiden. Es wird empfohlen, die Festigkeit der Schrauben regelmäßig zu überprüfen, um sicherzustellen, dass sich nichts gelöst hat. Überprüfen Sie dies immer vor dem ersten Gebrauch, nachdem Sie den Artikel aus dem Lager genommen haben.

Warnungen und Vorsichtsmaßnahmen

Bitte bewahren Sie diese Anleitung für die zukünftige Verwendung auf und lesen Sie sie vor dem Zusammenbau sorgfältig durch.

Stellen Sie sicher, dass Sie alle Teile und Hardware haben, wie in der Artikelliste angegeben.

Es werden 2 Erwachsene empfohlen, um Ihren Stuhl zu montieren.

Werfen Sie nichts von der Verpackung weg, bevor Sie überprüft haben, dass Sie alle Teile und das Befestigungspaket haben.

Überprüfen Sie vor dem Gebrauch alle Schrauben auf Festigkeit und überprüfen und ziehen Sie die Schrauben regelmäßig fest, um sicherzustellen, dass Ihr Stuhl ordnungsgemäß funktioniert. Einige Teile können scharfe Kanten/Ecken haben. Bitte treffen Sie grundlegende Sicherheitsvorkehrungen, um das Verletzungsrisiko zu verringern.

Hinweise

1. Chemisches Wasser kann zum Ausbleichen führen.
2. Reinigen und trocknen Sie die Stühle nach Regen.
3. Reinigen und trocknen Sie die Stühle rechtzeitig, wenn sie Chemikalien ausgesetzt waren.
4. Bitte decken Sie sie ab und lagern Sie sie, wenn Sie sie nicht verwenden.



DIESER ARTIKEL ENTHÄLT KLEINTEILE, DIE VON KINDERN VERSCHLUCKT WERDEN KÖNNEN. BITTE HALTEN SIE IHN WÄHREND DER INSTALLATION VON KINDERN UNTER 3 JAHREN UND HAUSTIEREN FERN.

LESEN SIE DIESE WARNHINWEISE UND BEWAHREN SIE SIE FÜR SPÄTERES NACHSCHLAGEN AUF

A 4PCS	B 8PCS	C 8PCS	D 4PCS	E M6X55 16PCS	F M6X70 16PCS
G M6 64PCS	H 32PCS	J 32PCS	K M6 32PCS	L $\varnothing 13 \times 5 \text{mm}$ 16PCS	 1PCS

HINWEIS: Die Beine B wurden vor Verlassen des Werks zusammengefügt und zusammengebunden. Zum Zusammenbau eines Stuhls müssen Sie daher ein Paar Beine B auseinandernehmen. Bitte vermischen Sie nicht alle Beine miteinander!

Haben Sie ein Problem? Lassen Sie sich von uns helfen.

LESEN SIE DIESE WARNHINWEISE UND SPEICHERN SIE SIE FÜR SPÄTERE NACHSCHLÄGE.
 LESEN SIE DIESE WARNHINWEISE UND SPEICHERN SIE SIE FÜR SPÄTERE NACHSCHLÄGE.
 Wenn Sie Fragen oder Wünsche haben, können Sie sich gerne an uns wenden.
 Wir werden unser Bestes tun, um Ihnen zu helfen.

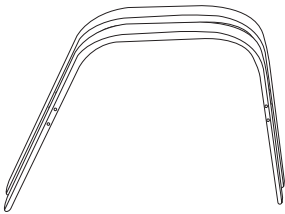

Vergleichen Sie die beiden Beine B, um zu sehen, ob sie

1

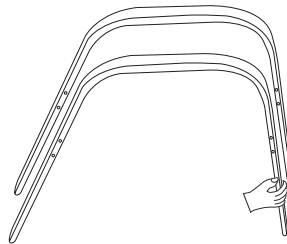

Wenn es anders ist, drücken oder ziehen Sie sanft mit Ihren Händen am unteren Ende des Beins.

2

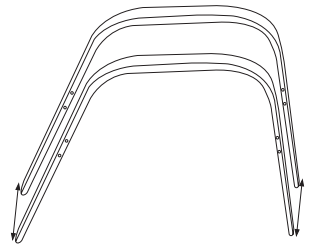

Stellen Sie vor der Installation sicher, dass die beiden B-Beine genau die gleiche Form haben.

3

1



Bitte ziehen Sie den Stoff vor der Montage an seinen Platz, falls er sich einzieht.

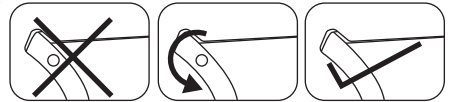
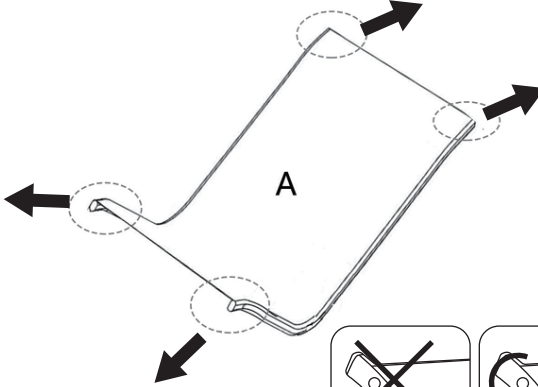

Die Schraubenlöcher an den Seitenstangen sollten nach innen zeigen, sonst wird die Rückenstange nicht richtig montiert.

2

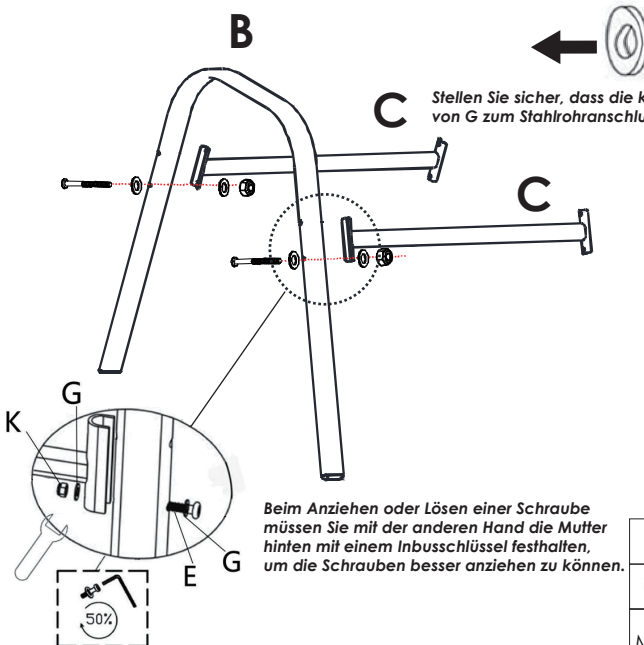

Stellen Sie sicher, dass die konkave Oberfläche von G zum Stahlrohranschluss zeigt.

Beim Anziehen oder Lösen einer Schraube müssen Sie mit der anderen Hand die Mutter hinten mit einem Inbusschlüssel festhalten, um die Schrauben besser anziehen zu können.



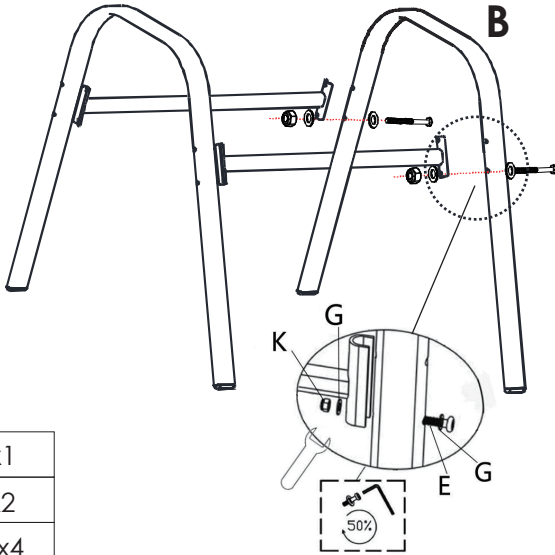

Ziehen Sie die Schrauben vorübergehend nur zu 50 % und nicht ganz fest, damit die nachfolgenden Schrauben besser auf die Schraubenlöcher ausgerichtet werden können.

	B x 1
	C x 2
	M6X55 E x 2
	G x 4
	M6 k x 2

3



← 
 Stellen Sie sicher, dass die konkave Oberfläche von G zum Stahlrohranschluss zeigt.

	B x1
	M6X55 E x2
	G x4
M6 	k x2

Die Schraube vorübergehend nur zu 50 % anziehen, jedoch nicht vollständig festziehen.

4

Das müssen Sie vor Schritt 5 wissen

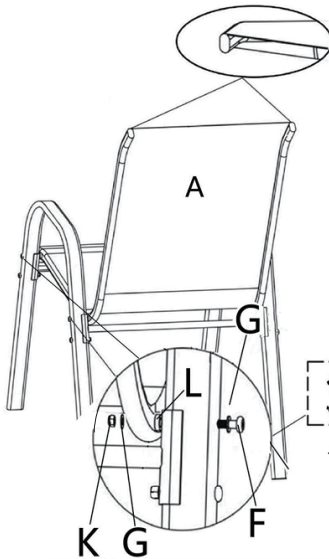

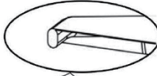
 Die leicht gebogene Kante des Zubehörfteils A bildet die Oberseite der Rückenlehne.

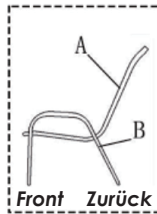

Die Vorderbeine sind fast senkrecht zum Boden angewinkelt.



Schrauben mit 20% anziehen

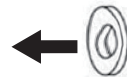

Stellen Sie sicher, dass die konkave Oberfläche von G zum Stahlrohranschluss zeigt.

5



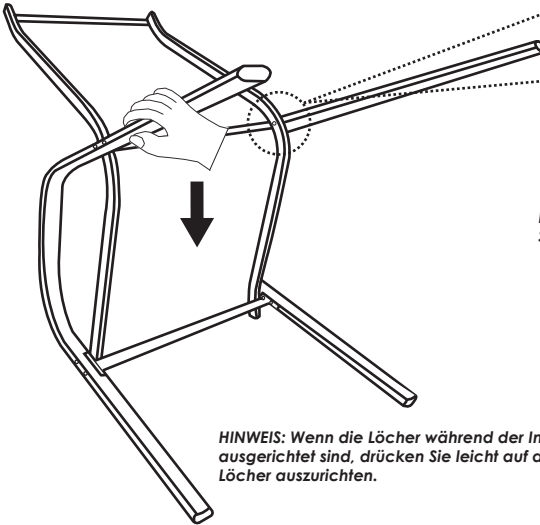

Die Schrauben für die Hinterbeine anbringen

Legen Sie den Stuhl zunächst mit den Hinterbeinen nach oben hin und ziehen Sie die Schrauben der Hinterbeine um 20 % fest.



Die richtige Reihenfolge zum Anbringen der Schrauben finden Sie in Schritt 4.

HINWEIS: Wenn die Löcher während der Installation nicht ausgerichtet sind, drücken Sie leicht auf das Bein, um die Löcher auszurichten.

	A x1
	F x2
	G x4
	L x2
	K x2

6



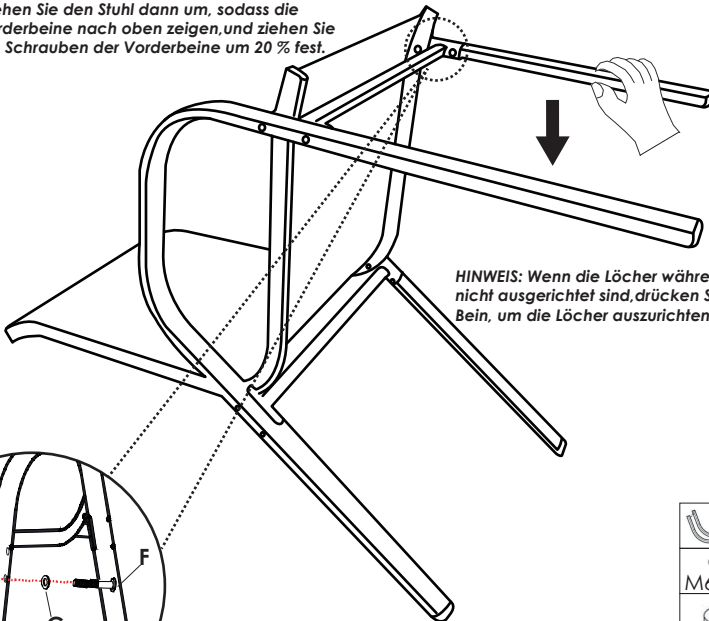

Die Schrauben für die Vorderbeine anbringen

Drehen Sie den Stuhl dann um, sodass die Vorderbeine nach oben zeigen, und ziehen Sie die Schrauben der Vorderbeine um 20 % fest.



HINWEIS: Wenn die Löcher während der Installation nicht ausgerichtet sind, drücken Sie leicht auf das Bein, um die Löcher auszurichten.

Die richtige Reihenfolge zum Anbringen der Schrauben finden Sie in Schritt 4.

	A x1
	F x2
	G x4
	L x2
	K x2

7

Beim Einsetzen der Rückenlehnenstange müssen Sie diese zunächst drehen, um ihre Länge zu verkürzen, und dann zum besseren Einsetzen vorsichtig an der Seitenstange ziehen.

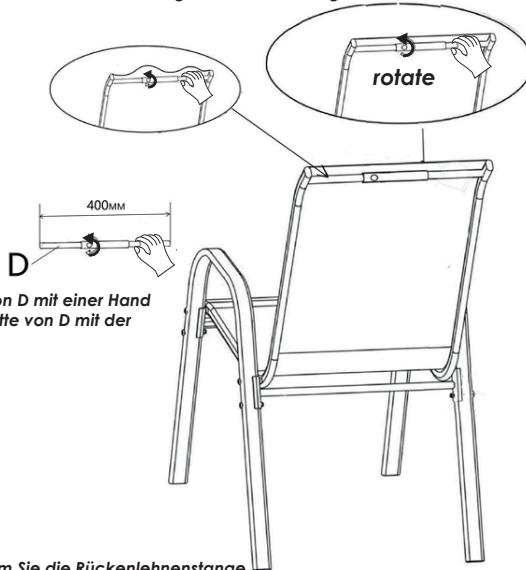

Halten Sie ein Ende von D mit einer Hand und drehen Sie die Mitte von D mit der anderen Hand.

Passen Sie die Länge an, indem Sie die Rückenlehnenstange drehen, um den Stoff vollständig auszubreiten.

8

Auf ebenem Boden zusammenbauen.

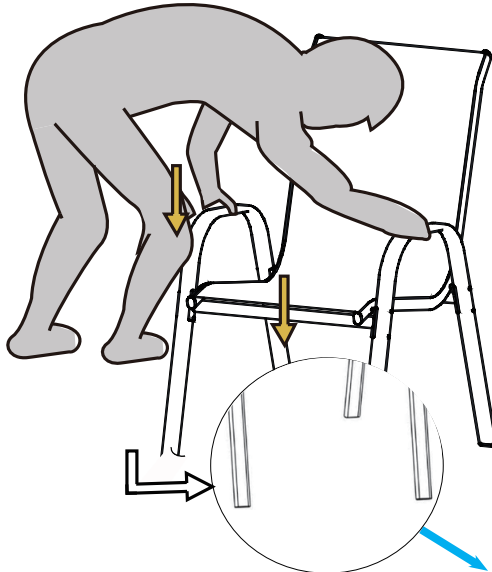

Stellen Sie sicher, dass alle vier Stuhlbeine vollen Bodenkontakt haben.

Wie vermeide ich, dass der Stuhl nach der Montage uneben ist?

1. Bitte stellen Sie den Stuhl zur Montage auf einen ebenen Untergrund.
2. Während Sie die Schrauben festziehen, verstellen Sie die Stuhlbeine kontinuierlich, bis sie stabil sind

9

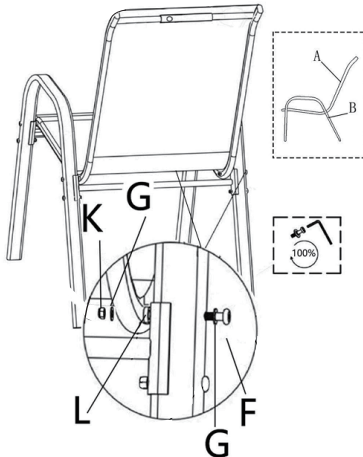

Wenn der Stuhl nach der Montage instabil ist, lösen Sie alle Schrauben leicht und passen Sie die Position von Beinen und Rahmen fein an. Ziehen Sie anschließend alle Schrauben wieder fest.

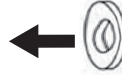

Stellen Sie sicher, dass die konkave Oberfläche von G zum Stahlrohranschluss zeigt.

HINWEIS: Wenn die Löcher während der Installation nicht ausgerichtet sind, drücken Sie bitte leicht auf das B-Bein, um die Löcher auszurichten.

	F x2
	G x4
	L x2

Ziehen Sie alle Schrauben vollständig fest.

	K x2
--	------

10

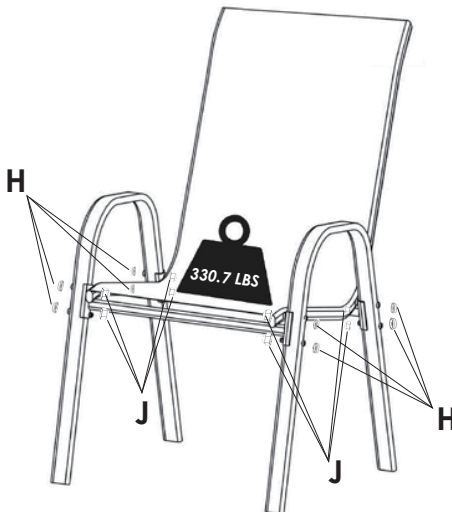

Nachdem Sie alle Schrauben festgezogen haben, montieren Sie die Kunststoffmuttern H und J.



Maximale Tragkraft: 330,7 Pfund

	H x8
	J x8

Instructions de montage !

INSTRUCTIONS DE MONTAGE ET D'UTILISATION

Le montage doit être effectué par 2 adultes. Retirez les autocollants et les papiers de protection avant l'assemblage et l'utilisation. Avant l'assemblage, assurez-vous que tous les composants sont inclus dans l'emballage.

Respecter les règles générales de sécurité lors du montage.

Pour assembler correctement l'article, suivez attentivement les instructions de montage incluses ici.

L'article doit être monté sur une surface ferme et plane, exempte de tout ce qui pourrait l'endommager.

Le montage sur une surface inégale telle que le béton peut provoquer une instabilité et entraîner des bosses ou des rayures qui pourraient endommager l'article.

Avant d'utiliser l'article, assurez-vous qu'il est bien assemblé. Il n'est pas recommandé de secouer ou de soumettre le produit à un impact excessif. Ne frappez pas la surface avec des objets durs et/ou pointus. Le produit est destiné à un usage domestique.

CONSIGNES D'ENTRETIEN

Gardez l'article à l'écart des sources de chaleur. N'utilisez pas de produits de nettoyage agressifs pour le nettoyage. Nettoyez-le avec un chiffon humide et séchez-le.

Pour conserver les objets et leurs parties métalliques en bon état, il est important qu'ils ne soient pas exposés aux intempéries. Le produit doit être stocké dans un environnement propre et sec, en éliminant toute humidité avec un chiffon sec avant le stockage pour éviter la corrosion. Il est recommandé de vérifier régulièrement le serrage des vis pour s'assurer que rien ne s'est desserré. Vérifiez toujours avant la première utilisation après avoir retiré l'article du stockage.

Avertissements et précautions

Veillez conserver ces instructions pour une utilisation future et les lire attentivement avant l'assemblage.

Assurez-vous d'avoir toutes les pièces et le matériel indiqués dans la liste des articles.

2 adultes sont recommandés pour assembler votre chaise.

Ne jetez aucun emballage avant de vérifier que vous disposez de toutes les pièces et du kit de montage.

Vérifiez le serrage de toutes les vis avant utilisation et vérifiez et serrez les vis régulièrement pour vous assurer que votre chaise fonctionne correctement. Certaines pièces peuvent avoir des bords/coins tranchants. Veuillez prendre des précautions de sécurité de base pour réduire le risque de blessure.

Astuces

1. L'eau chimique peut provoquer une décoloration.
2. Nettoyez et séchez les chaises après la pluie.
3. Nettoyez et séchez les chaises à temps si elles ont été exposées à des produits chimiques.
4. Veuillez couvrir et ranger lorsque vous ne vous en servez pas.



CET ARTICLE CONTIENT DE PETITES PIÈCES QUI PEUVENT ÊTRE AVALÉES PAR LES ENFANTS. VEUILLEZ LE GARDER LOIN DES ENFANTS DE MOINS DE 3 ANS ET DES ANIMAUX PENDANT L'INSTALLATION.

LISEZ CES AVERTISSEMENTS ET CONSERVEZ-LES POUR RÉFÉRENCE FUTURE

A 4PCS	B 8PCS	C 8PCS	D 4PCS	E M6X55 16PCS	F M6X70 16PCS
G M6 64PCS	H M6 32PCS	J M6 32PCS	K M6 32PCS	L $\varnothing 13 \times 5 \text{mm}$ 16PCS	 1PCS

REMARQUE : Les pieds B ont été assemblés et attachés ensemble avant de quitter l'usine. Par conséquent, pour assembler une chaise, vous devez démonter une paire de pieds B. S'il vous plaît, ne mélangez pas toutes les jambes ensemble !

Avez-vous un problème? Laissez-nous vous aider.

LISEZ CES AVERTISSEMENTS ET CONSERVEZ-LES POUR RÉFÉRENCE FUTURE.
LISEZ CES AVERTISSEMENTS ET CONSERVEZ-LES POUR RÉFÉRENCE FUTURE.

Si vous avez des questions ou des demandes, n'hésitez pas à nous contacter. nous ferons de notre mieux pour vous aider.

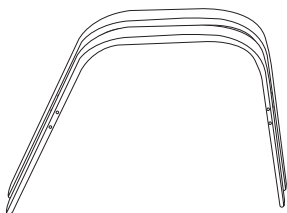

Comparez les deux pattes B pour voir si elles

1

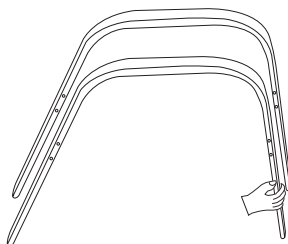

Si c'est différent, poussez ou tirez doucement le bas de la jambe avec vos mains.

2

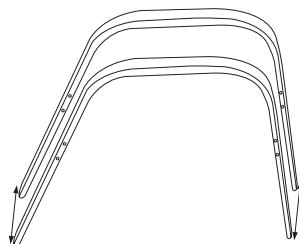

Avant l'installation, assurez-vous que les deux pieds B ont exactement la même forme.

3

1



Veillez mettre le tissu en place avant l'assemblage au cas où il rétrécirait.

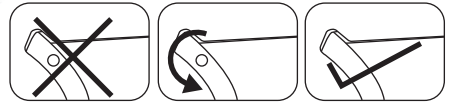
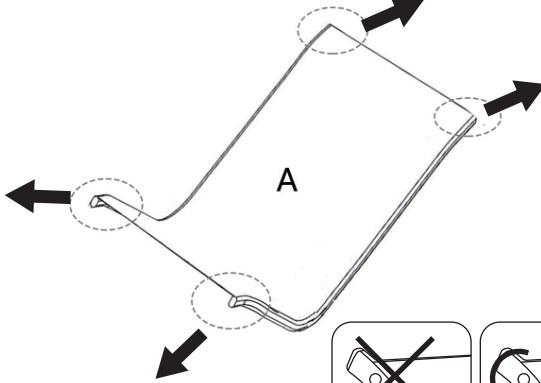

Lorsque vous serrez ou desserrez une vis, vous devez maintenir l'arrière de l'écrou avec une clé Allen avec votre autre main pour aider à serrer les vis.

2

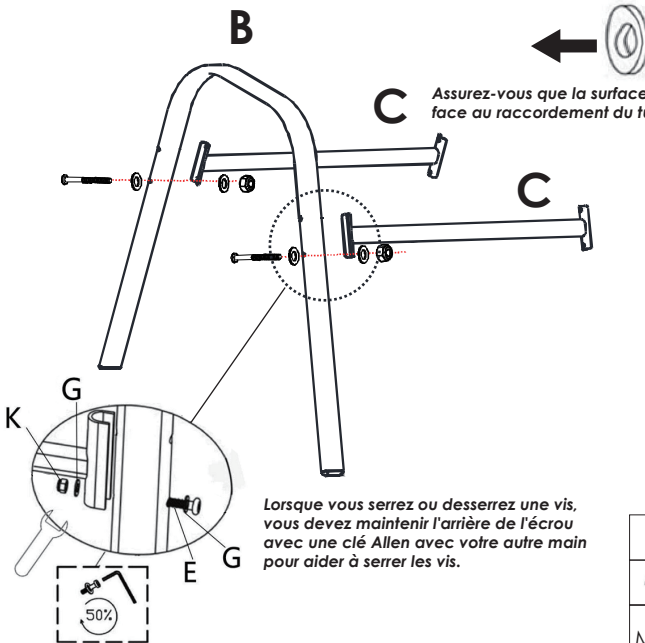

Lorsque vous serrez ou desserrez une vis, vous devez maintenir l'arrière de l'écrou avec une clé Allen avec votre autre main pour aider à serrer les vis.

Ne serrez temporairement les vis qu'à 50 % plutôt que complètement afin que les vis suivantes puissent mieux s'aligner avec les trous de vis.

	B x1
	C x2
	E x2 M6X55
	G x4
	k x2 M6

3

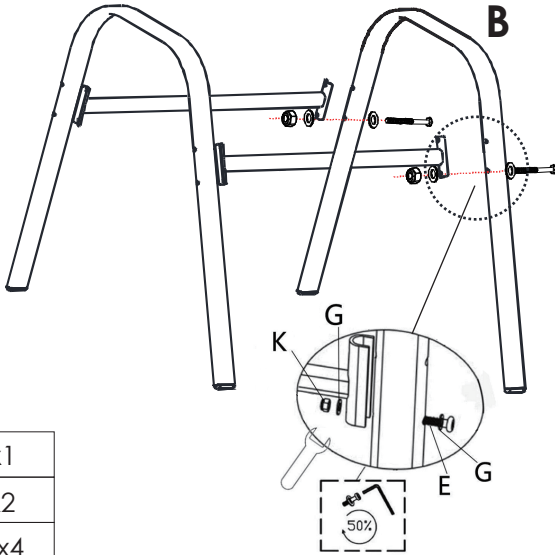

Assurez-vous que la surface concave de G fait face au raccordement du tuyau en acier.

 B x1

 M6X55 E x2

 G x4

M6  k x2

Serrez temporairement la vis à seulement 50 %, mais ne la serrez pas complètement.

4

Voici ce que vous devez savoir avant l'étape 5

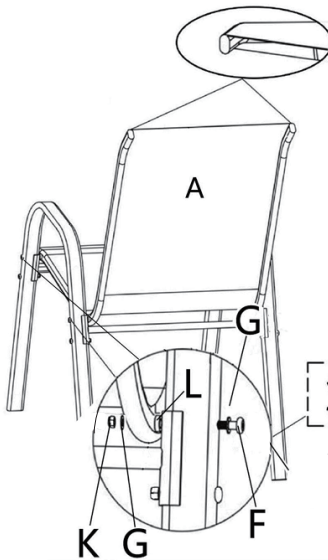

Le bord légèrement incurvé de l'accessoire A forme le dessus le dossier.

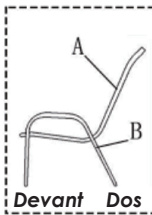

Les pattes avant sont inclinées presque perpendiculairement au sol.



Serrer les vis à 20 %



Assurez-vous que la surface concave de G fait face au raccordement du tuyau en acier.

5



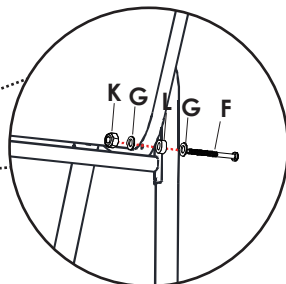
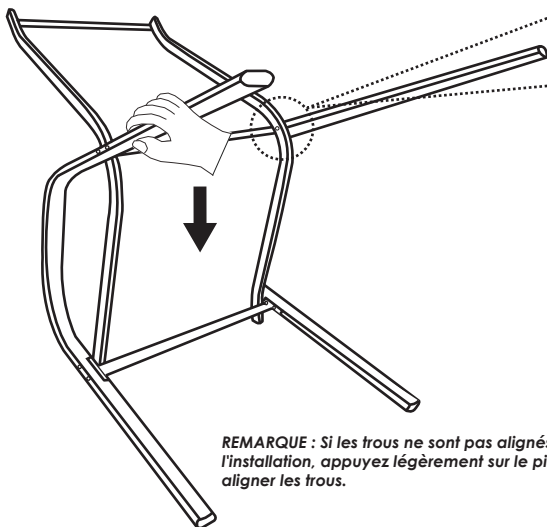

Installez les vis pour les pieds arrière

Tout d'abord, posez la chaise avec les pieds arrière vers le haut et serrez les vis des pieds arrière à 20 %.



Pour connaître l'ordre correct de fixation des vis, voir l'étape 4.

REMARQUE : Si les trous ne sont pas alignés lors de l'installation, appuyez légèrement sur le pied pour aligner les trous.

 A x1
 F x2
 G x4
 L x2
 K x2

6

Installez les vis pour les pieds avant



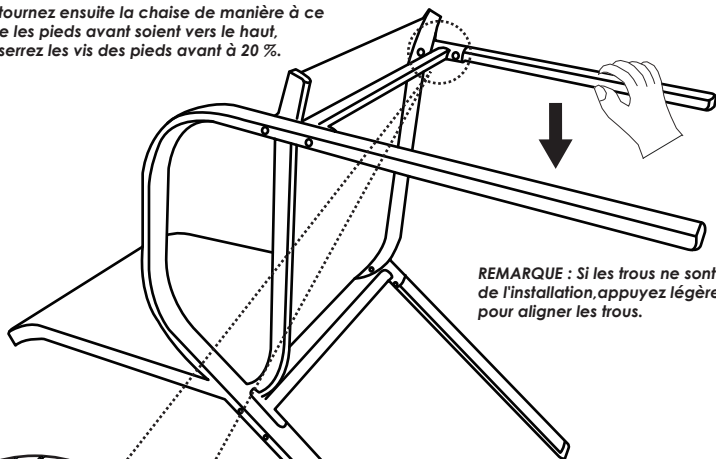

Retournez ensuite la chaise de manière à ce que les pieds avant soient vers le haut, et serrez les vis des pieds avant à 20 %.

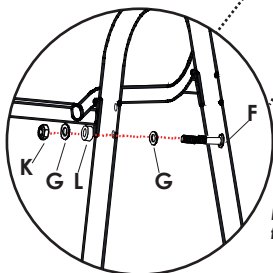

REMARQUE : Si les trous ne sont pas alignés lors de l'installation, appuyez légèrement sur le pied pour aligner les trous.



Pour connaître l'ordre correct de fixation des vis, voir l'étape 4.

 A x1
 F x2
 G x4
 L x2
 K x2

7

Lors de l'insertion de la barre de dossier, vous devez d'abord la faire pivoter pour raccourcir sa longueur, puis tirer doucement la barre latérale pour une meilleure insertion.

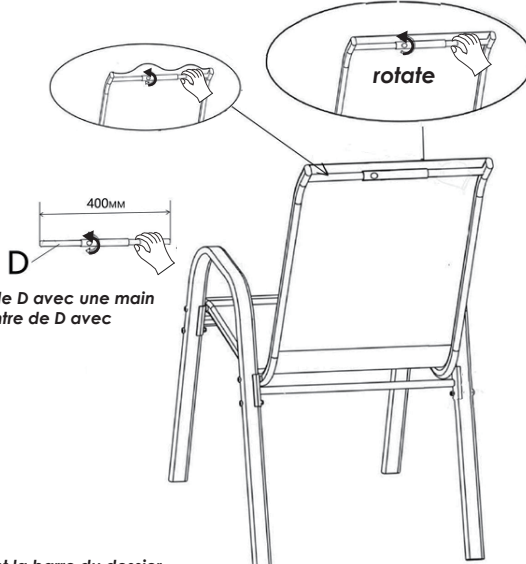

Tenez une extrémité de D avec une main et faites pivoter le centre de D avec l'autre main.

Ajustez la longueur en tournant la barre du dossier pour étaler complètement le tissu.

8

Assemblez sur un terrain plat.

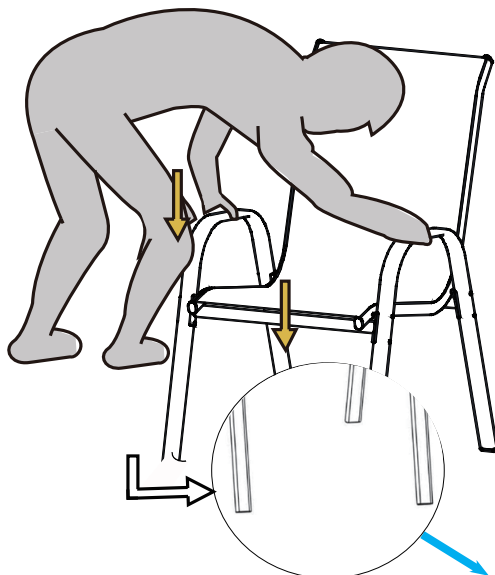

Assurez-vous que les quatre pieds de la chaise sont entièrement en contact avec le sol.

Comment puis-je éviter que la chaise ne soit inégale après l'assemblage ?

1. Veuillez placer la chaise sur une surface plane pour l'assembler.
2. Tout en serrant les vis, ajustez continuellement les pieds de la chaise jusqu'à ce qu'ils soient stables.

9

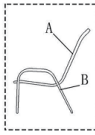
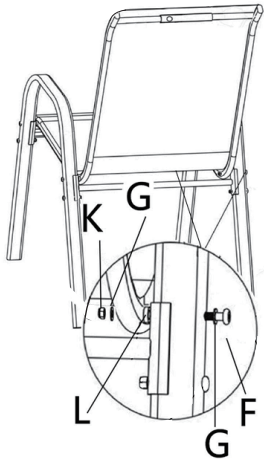

Si la chaise est instable après l'assemblage, desserrez légèrement toutes les vis et ajustez finement la position des pieds et du cadre. Ensuite, resserrez toutes les vis.

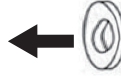

Assurez-vous que la surface concave de G fait face au raccordement du tuyau en acier.

REMARQUE : Si les trous ne sont pas alignés lors de l'installation, veuillez appuyer légèrement sur le pied B pour aligner les trous.

M6X70 F x2

G x4

Serrez complètement toutes les vis.

K x2

L x2

10

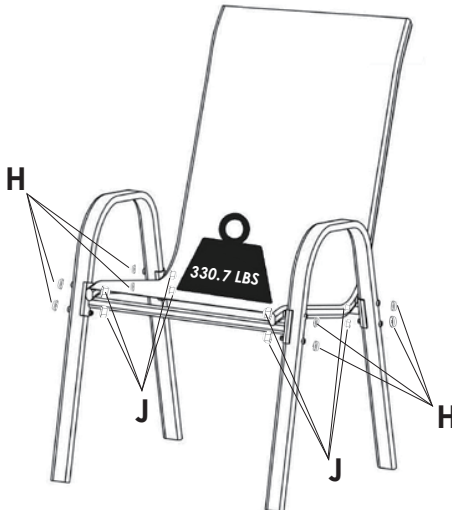

Après avoir serré toutes les vis, installez les écrous en plastique H et J.



Capacité de charge maximale : 330,7 livres

H x8

J x8

Istruzioni per il montaggio!

ISTRUZIONI PER IL MONTAGGIO E L'USO

Il montaggio deve essere effettuato da 2 adulti. Rimuovere adesivi e carte protettive prima del montaggio e dell'uso. Prima del montaggio, assicurarsi che tutti i componenti siano inclusi nella confezione.

Rispettare le norme generali di sicurezza durante il montaggio.

Per assemblare correttamente l'articolo seguire attentamente le istruzioni di montaggio qui incluse.

L'articolo deve essere montato su una superficie solida e piana, priva di qualsiasi cosa che possa danneggiarlo.

Il montaggio su una superficie irregolare come il cemento può causare instabilità e provocare ammaccature o graffi che potrebbero danneggiare l'articolo.

Prima di utilizzare l'articolo, assicurarsi che sia ben assemblato. Si sconsiglia di scuotere o sottoporre il prodotto a urti eccessivi. Non colpire la superficie con oggetti duri e/o taglienti. Il prodotto è destinato all'uso domestico.

NOTE SULLA MANUTENZIONE

Tenere l'oggetto lontano da fonti di calore. Non utilizzare detergenti aggressivi per la pulizia. Pulirlo con un panno umido e asciugarlo.

Per mantenere in buono stato gli oggetti e le loro parti metalliche è importante che non siano esposti alle intemperie. Il prodotto deve essere conservato in un ambiente pulito e asciutto, rimuovendo l'eventuale umidità con un panno asciutto prima di riporlo per evitare la corrosione. Si consiglia di controllare regolarmente il serraggio delle viti per assicurarsi che nulla si sia allentato. Controllare sempre prima del primo utilizzo dopo aver rimosso l'articolo dalla custodia.

Avvertenze e precauzioni

Si prega di conservare queste istruzioni per un utilizzo futuro e di leggerle attentamente prima del montaggio.

Assicurarsi di avere tutte le parti e l'hardware come indicato nell'elenco degli articoli.

Si consigliano 2 adulti per assemblare la sedia.

Non buttare via l'imballaggio prima di aver controllato di avere tutte le parti e il pacchetto di montaggio.









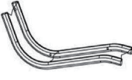

Controllare il serraggio di tutte le viti prima dell'uso e controllare e serrare le viti regolarmente per garantire che la sedia funzioni correttamente. Alcune parti potrebbero presentare bordi/angoli taglienti. Si prega di adottare le precauzioni di sicurezza di base per ridurre il rischio di lesioni.

Suggerimenti

1. L'acqua chimica può causare scolorimento.
2. Pulisci e asciuga le sedie dopo la pioggia.
3. Pulisci e asciuga tempestivamente le sedie se sono state esposte a sostanze chimiche.
4. Si prega di coprire e riporre quando non in uso.

! QUESTO ARTICOLO CONTIENE PICCOLE PARTI CHE POSSONO ESSERE INGERITE DAI BAMBINI. SI PREGA DI TENERE LONTANO DAI BAMBINI SOTTO I 3 ANNI E DAGLI ANIMALI DURANTE L'INSTALLAZIONE.

LEGGERE QUESTE AVVERTENZE E CONSERVARLE PER RIFERIMENTO FUTURO

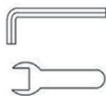
A  4PCS	B  8PCS	C  8PCS	D  4PCS	E M6X55  16PCS	F M6X70  16PCS
G  M6 64PCS	H  32PCS	J  32PCS	K  M6 32PCS	L  Φ 13x5mm 16PCS	 1PCS

NOTA: le gambe B sono state assemblate e legate insieme prima di lasciare la fabbrica. Pertanto, per assemblare una sedia è necessario smontare una coppia di gambe B. Per favore, non mescolare tutte le gambe insieme!

Hai un problema? Lascia che ti aiutiamo.

LEGGERE QUESTE AVVERTENZE E CONSERVARLE PER RIFERIMENTO FUTURO.
LEGGERE QUESTE AVVERTENZE E CONSERVARLE PER RIFERIMENTO FUTURO.

Se avete domande o richieste, non esitate a contattarci.

Faremo del nostro meglio per aiutarvi.

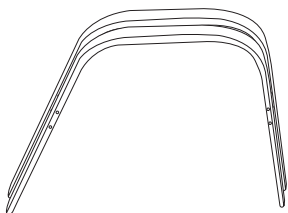

Confronta le due gambe B per vedere se

1

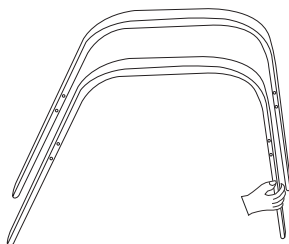

Se è diverso, spingere o tirare delicatamente la parte inferiore della gamba con le mani.

2

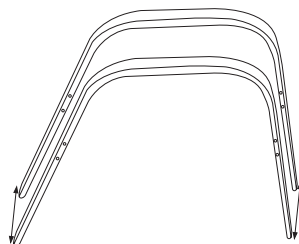

Prima dell'installazione, assicurarsi che le due gambe B abbiano esattamente la stessa forma.

3

1



Si prega di mettere il tessuto in posizione prima del montaggio nel caso in cui si restringa.

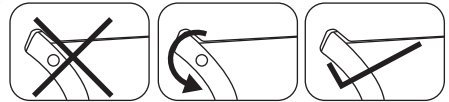
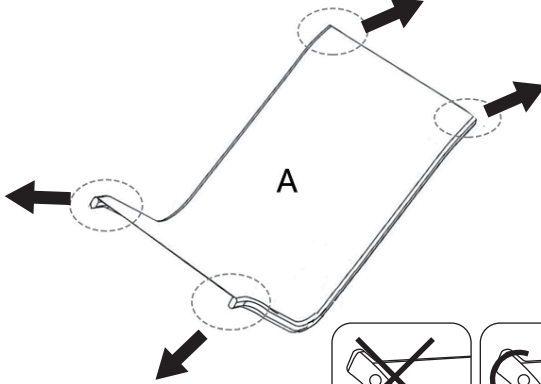

I fori per le viti sulle barre laterali devono essere rivolti verso l'interno, altrimenti la barra posteriore non verrà installata correttamente.

2

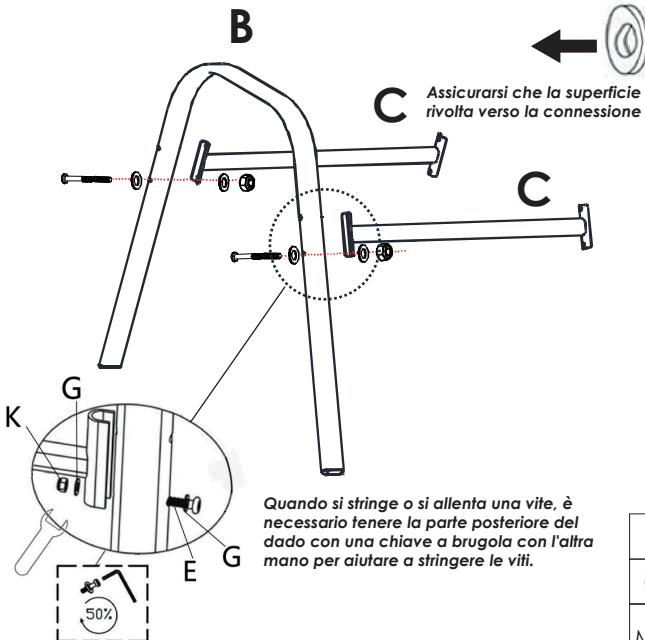

Assicurarsi che la superficie concava di G sia rivolta verso la connessione del tubo in acciaio.

Quando si stringe o si allenta una vite, è necessario tenere la parte posteriore del dado con una chiave a brugola con l'altra mano per aiutare a stringere le viti.



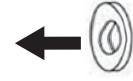
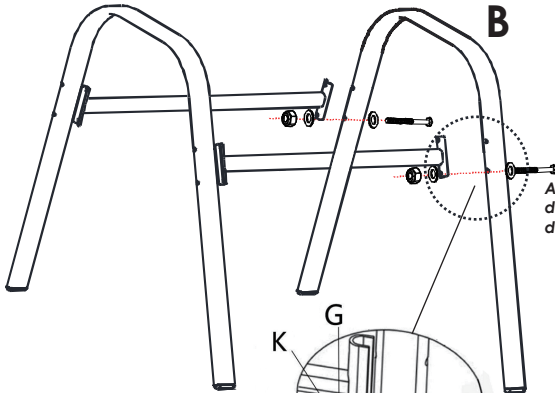

Stringere temporaneamente le viti solo al 50% anziché completamente in modo che le viti successive possano allinearsi meglio ai fori delle viti.

	B x 1
	C x 2
	M6X55 E x 2
	G x 4
	M6 k x 2

3



Assicurarsi che la superficie concava di G sia rivolta verso la connessione del tubo in acciaio.

	B x1
	E x2
	G x4
M6 	k x2

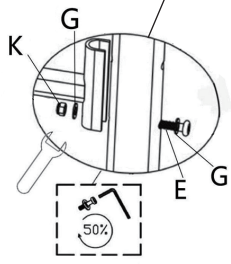

Stringere temporaneamente la vite solo al 50%, ma non serrarla completamente.

4

Ecco cosa devi sapere prima del passaggio 5



Il bordo leggermente curvato dell'accessorio A costituisce il top lo schienale.

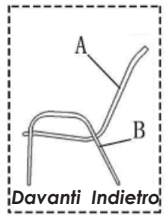
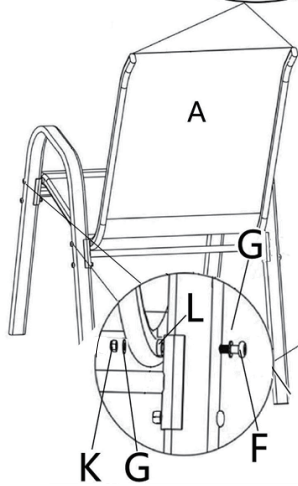

Le zampe anteriori sono angolate quasi perpendicolari al suolo.



Stringere le viti al 20%

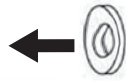

Assicurarsi che la superficie concava di G sia rivolta verso la connessione del tubo in acciaio.



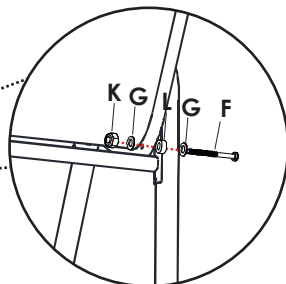
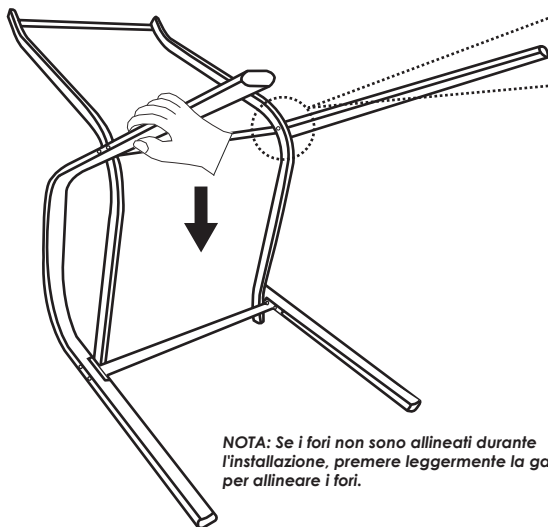

5**Installare le viti per le gambe posteriori**

Per prima cosa, appoggia la sedia con le gambe posteriori rivolte verso l'alto e stringi le viti delle gambe posteriori del 20%.



Per l'ordine corretto di fissaggio delle viti, vedere il passaggio 4.

NOTA: Se i fori non sono allineati durante l'installazione, premere leggermente la gamba per allineare i fori.

	A x1
	F x2
	G x4
	L x2
	K x2

6**Installare le viti per le gambe anteriori**



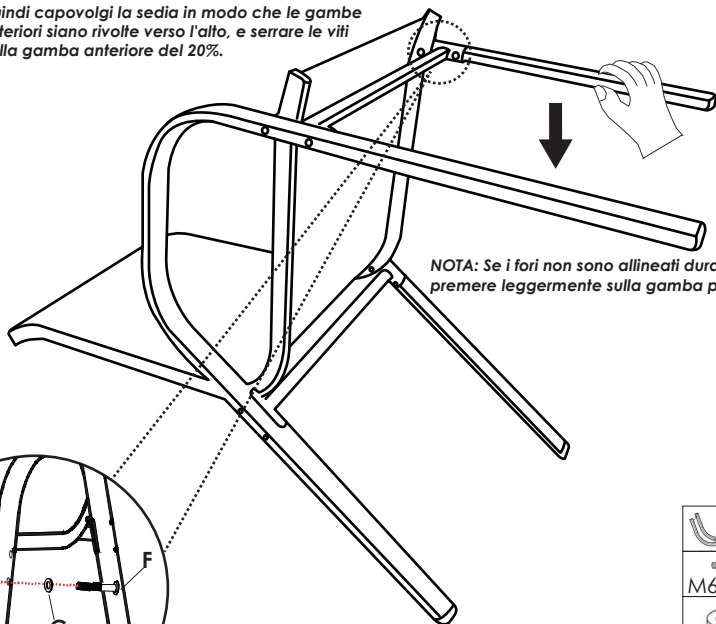

Quindi capovolgi la sedia in modo che le gambe anteriori siano rivolte verso l'alto, e serrare le viti della gamba anteriore del 20%.

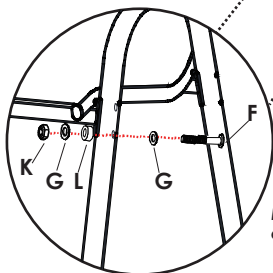

NOTA: Se i fori non sono allineati durante l'installazione, premere leggermente sulla gamba per allineare i fori.



Per l'ordine corretto di fissaggio delle viti, vedere il passaggio 4.

	A x1
	F x2
	G x4
	L x2
	K x2

7

Quando si inserisce la barra dello schienale è necessario prima ruotarla per accorciarne la lunghezza e poi tirare delicatamente la barra laterale per un migliore inserimento.

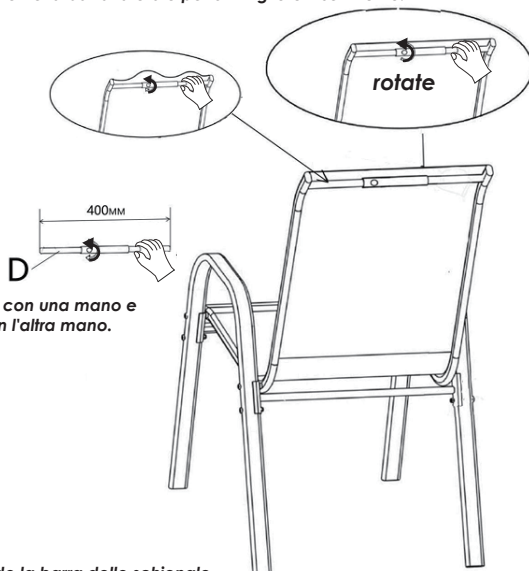

Tieni un'estremità di D con una mano e ruota il centro di D con l'altra mano.

Regolare la lunghezza ruotando la barra dello schienale per distendere completamente il tessuto.

8

Assemblare su terreno pianeggiante.

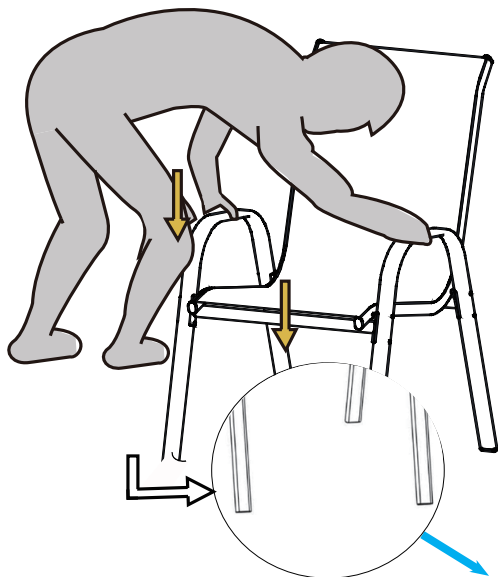

Assicurati che tutte e quattro le gambe della sedia siano completamente a contatto con il pavimento.

Come posso evitare che la sedia risulti irregolare dopo il montaggio?

1. Posizionare la sedia su una superficie piana per il montaggio.
2. Stringendo le viti, regolare continuamente le gambe della sedia fino a renderle stabili

9

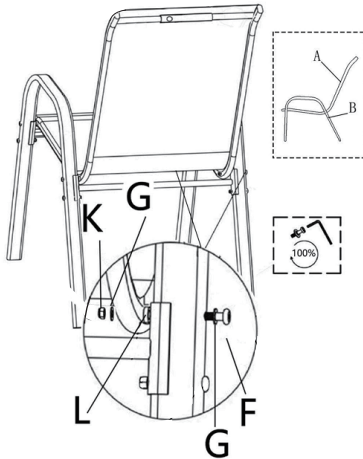

Se la sedia risulta instabile dopo il montaggio, allentare leggermente tutte le viti e regolare con precisione la posizione delle gambe e del telaio, quindi serrare nuovamente tutte le viti.

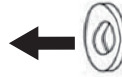

Assicurarsi che la superficie concava di G sia rivolta verso la connessione del tubo in acciaio.

NOTA: Se i fori non sono allineati durante l'installazione, premere leggermente la gamba B per allineare i fori.

Stringere completamente tutte le viti.

 F x2
M6X70

 G x4

 K x2

 L x2

10

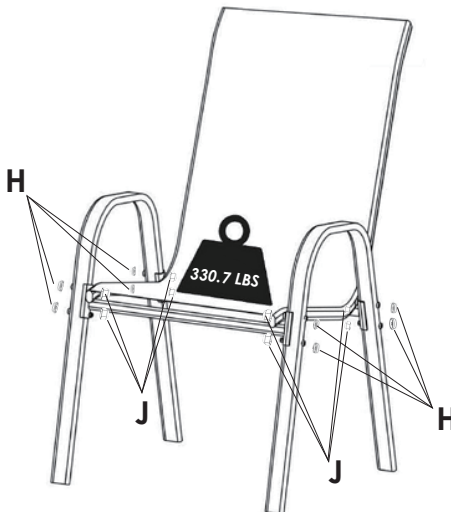

Dopo aver serrato tutte le viti, installare i dadi in plastica H e J.



Capacità di carico massima: 330,7 libbre

 H x8

 J x8

Instrucciones de montaje!

INSTRUCCIONES DE MONTAJE Y USO

El montaje debe ser realizado por 2 adultos. Retire pegatinas y papeles protectores antes del montaje y uso. Antes del montaje, asegúrese de que todos los componentes estén incluidos en el embalaje.

Observe las normas generales de seguridad durante el montaje.

Para ensamblar correctamente el artículo, siga atentamente las instrucciones de montaje incluidas aquí.

El artículo debe montarse sobre una superficie firme, plana y libre de cualquier elemento que pueda dañarlo.

El montaje sobre una superficie irregular, como concreto, puede causar inestabilidad y provocar abolladuras o rayones que podrían dañar el artículo.

Antes de utilizar el artículo, asegúrese de que esté bien ensamblado. No se recomienda agitar ni someter el producto a impactos excesivos. No golpee la superficie con objetos duros y/o punzantes. El producto está destinado a uso doméstico.

NOTAS DE MANTENIMIENTO

Mantenga el artículo alejado de fuentes de calor. No utilice agentes de limpieza agresivos para la limpieza. Límpiolo con un paño húmedo y séquelo.

Para mantener en buen estado los artículos y sus partes metálicas, es importante que no queden expuestos a la intemperie. El producto debe almacenarse en un ambiente limpio y seco, eliminando la humedad con un paño seco antes del almacenamiento para evitar la corrosión. Se recomienda comprobar periódicamente el apriete de los tornillos para asegurarse de que no se haya soltado nada. Verifique siempre antes del primer uso después de sacar el artículo del almacenamiento.

Advertencias y precauciones

Guarde estas instrucciones para uso futuro y léalas atentamente antes de realizar el montaje.

Asegúrese de tener todas las piezas y el hardware como se indica en la lista de artículos.

Se recomiendan 2 adultos para montar su silla.

No deseche nada del embalaje antes de comprobar que tiene todas las piezas y el paquete de montaje.

Verifique que todos los tornillos estén apretados antes de usarlos y verifique y apriete los tornillos regularmente para asegurarse de que su silla esté funcionando correctamente.

Algunas piezas pueden tener bordes/esquinas filosas. Tome precauciones de seguridad básicas para reducir el riesgo de lesiones.

Consejos

1. El agua química puede provocar decoloración.
2. Limpiar y secar las sillas después de la lluvia.
3. Limpia y seca las sillas a tiempo si han estado expuestas a productos químicos.
4. Cubra y almacene cuando no esté en uso.



ESTE ARTÍCULO CONTIENE PIEZAS PEQUEÑAS QUE PUEDEN SER TRAGADAS POR LOS NIÑOS. MANTÉNGALO ALEJADO DE NIÑOS MENORES DE 3 AÑOS Y MASCOTAS DURANTE LA INSTALACIÓN.

LEA ESTAS ADVERTENCIAS Y CONSÉRDELAS PARA FUTURAS CONSULTAS

A 4PCS	B 8PCS	C 8PCS	D 4PCS	E M6X55 16PCS	F M6X70 16PCS
G M6 64PCS	H 32PCS	J 32PCS	K M6 32PCS	L Φ 13x5mm 16PCS	 1PCS

NOTA: Las patas B fueron ensambladas y unidas antes de salir de fábrica. Por lo tanto, para montar una silla es necesario desmontar un par de patas B. ¡Por favor, no mezcle todas las piernas!

¿Tiene usted un problema? Dejanos ayudarte.

LEA ESTAS ADVERTENCIAS Y GUÉRDELAS PARA FUTURAS CONSULTAS.
 LEA ESTAS ADVERTENCIAS Y GUÉRDELAS PARA FUTURAS CONSULTAS.
 Si tiene alguna pregunta o solicitud, no dude en contactarnos.
 Haremos todo lo posible para ayudarle.

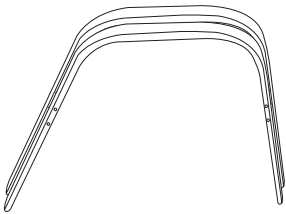

Compara las dos patas B para ver si

1

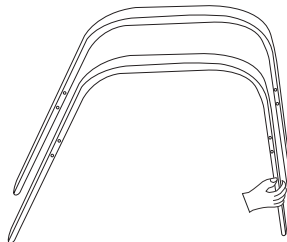

Si es diferente, empuje o tire suavemente de la parte inferior de la pierna con las manos.

2

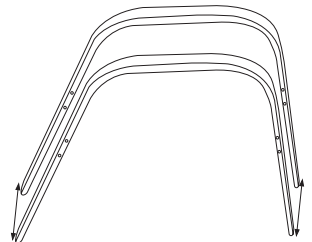

Antes de la instalación, asegúrese de que las dos patas B fengan exactamente la misma forma.

3

1



Por favor, coloque la tela en su lugar antes del montaje en caso de que se encoja.

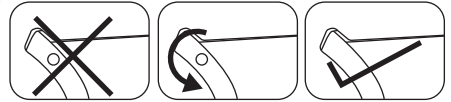
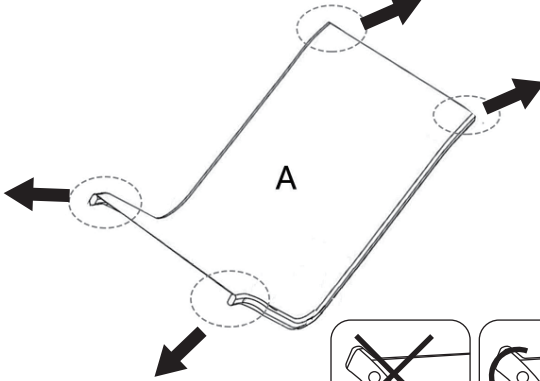

Por favor, coloque la tela en su lugar antes del montaje en caso de que se encoja.



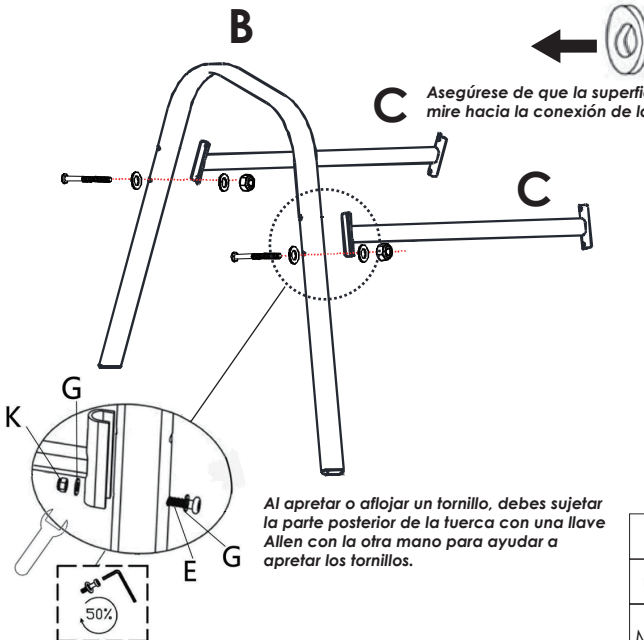

2



Asegúrese de que la superficie cóncava de G mire hacia la conexión de la tubería de acero.

Al apretar o aflojar un tornillo, debes sujetar la parte posterior de la tuerca con una llave Allen con la otra mano para ayudar a apretar los tornillos.



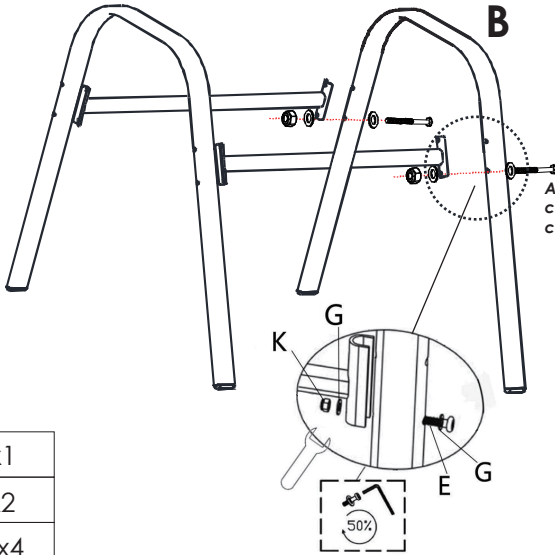

Apriete temporalmente los tornillos solo al 50 % en lugar de completamente para que los tornillos posteriores puedan alinearse mejor con los orificios para tornillos.

	B x1
	C x2
	E x2
	G x4
	k x2

3



Asegúrese de que la superficie cóncava de G mire hacia la conexión de la tubería de acero.

	B x1
	M6X55 E x2
	G x4
M6 	k x2

Apriete temporalmente el tornillo sólo al 50%, pero no lo apriete completamente.

4

Esto es lo que necesita saber antes del paso 5

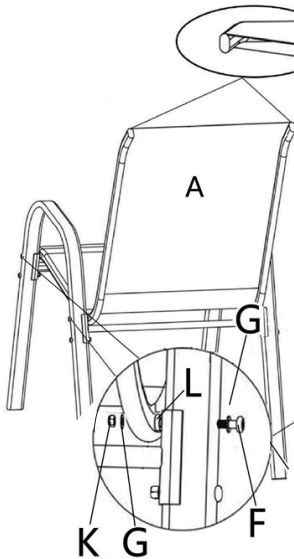

El borde ligeramente curvado del accesorio A forma la parte superior, el respaldo.

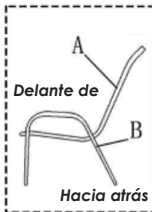

Las patas delanteras tienen un ángulo casi perpendicular al suelo.



Apretar los tornillos con un 20%



Asegúrese de que la superficie cóncava de G mire hacia la conexión de la tubería de acero.



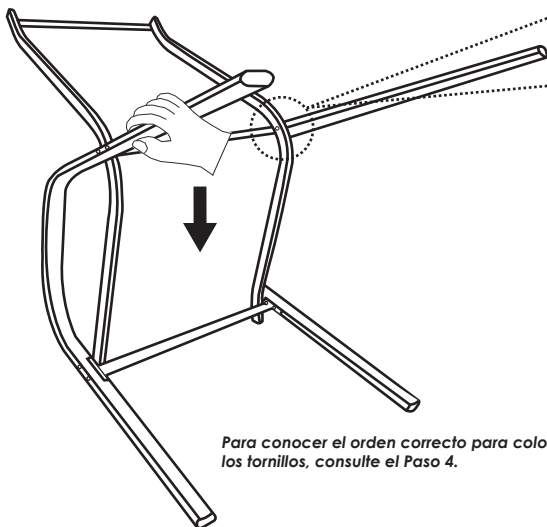

5**Instale los tornillos para las patas traseras.**

Primero, coloque la silla con las patas traseras hacia arriba y apriete los tornillos de las patas traseras en un 20%.



Para conocer el orden correcto para colocar los tornillos, consulte el Paso 4.

Para conocer el orden correcto para colocar los tornillos, consulte el Paso 4.

	A x1
	F x2
	G x4
	L x2
	K x2



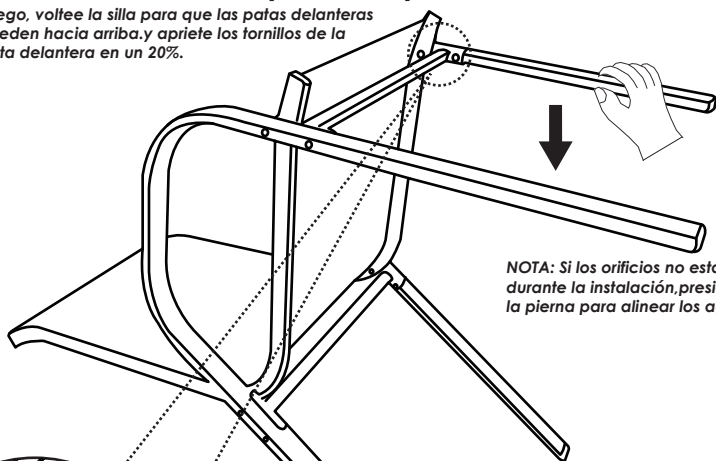

6**Instale los tornillos para las patas delanteras.**

Luego, voltee la silla para que las patas delanteras queden hacia arriba, y apriete los tornillos de la pata delantera en un 20%.



NOTA: Si los orificios no están alineados durante la instalación, presione ligeramente la pierna para alinear los agujeros.

Para conocer el orden correcto para colocar los tornillos, consulte el Paso 4.

	A x1
	F x2
	G x4
	L x2
	K x2

7

Al insertar la barra del respaldo, primero debe girarla para acortar su longitud y luego tirar suavemente de la barra lateral para una mejor inserción.

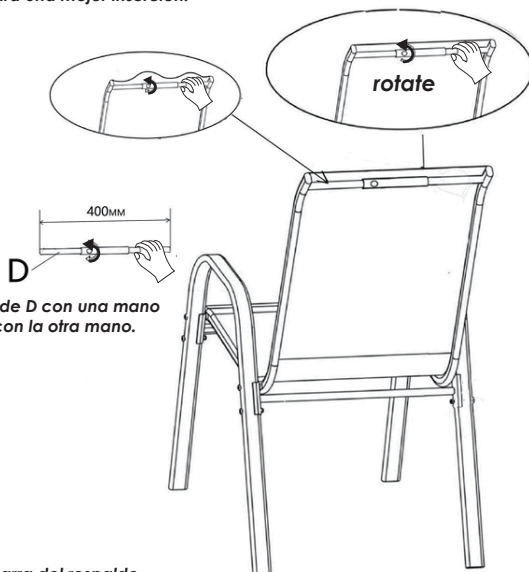

Sostenga un extremo de D con una mano y gire el centro de D con la otra mano.

Ajuste la longitud girando la barra del respaldo para extender completamente la tela.

8

Montar en terreno nivelado.

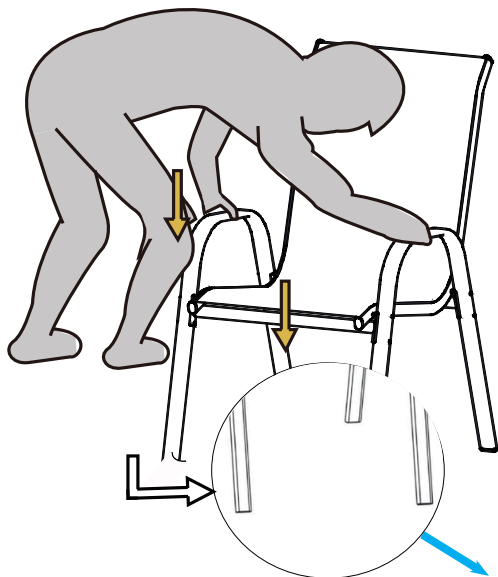

Asegúrese de que las cuatro patas de la silla estén en pleno contacto con el suelo.

¿Cómo evito que la silla quede desnivelada después del montaje?

1. Coloque la silla sobre una superficie plana para ensamblarla.
2. Mientras aprieta los tornillos, ajuste continuamente las patas de la silla hasta que estén estables.

9

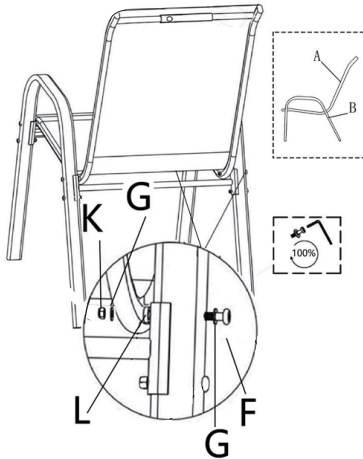

Si la silla está inestable después del montaje, afloje ligeramente todos los tornillos y ajuste con precisión la posición de las patas y el marco. Luego apriete todos los tornillos nuevamente.

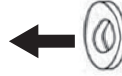

Asegúrese de que la superficie cóncava de G mire hacia la conexión de la tubería de acero.

NOTA: Si los orificios no están alineados durante la instalación, presione ligeramente la pata B para alinear los orificios.

Apriete todos los tornillos por completo.

 F x2
M6X70

 G x4

 K x2

 L x2

10

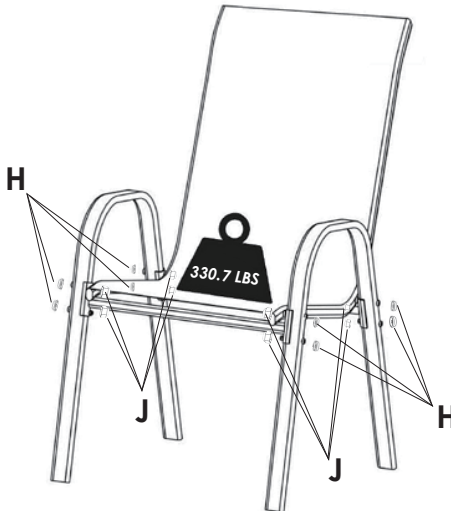

Después de apretar todos los tornillos, instale las tuercas de plástico H y J.



Capacidad de carga máxima: 330,7 libras

 H x8

 J x8

Made in China 

