

ASSEMBLY INSTRUCTION

44" ROUND DINING TABLE

A Table Top

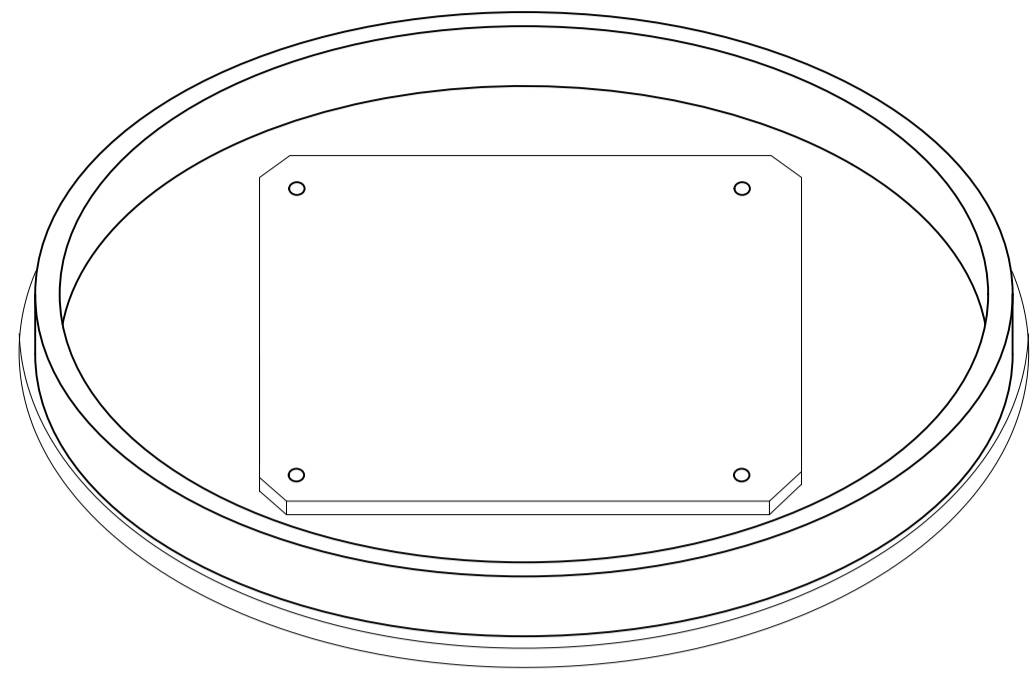

1 PC

B Table Top Cross Base

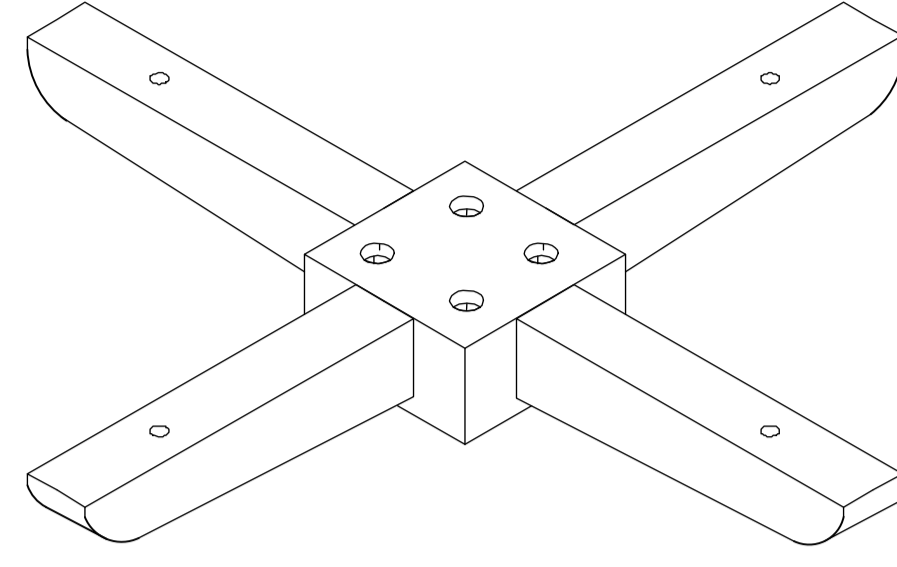

1 PC

C Connecting Plate

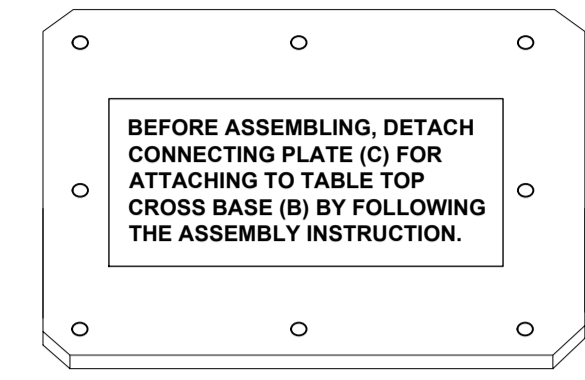

1 PC

D Table Base

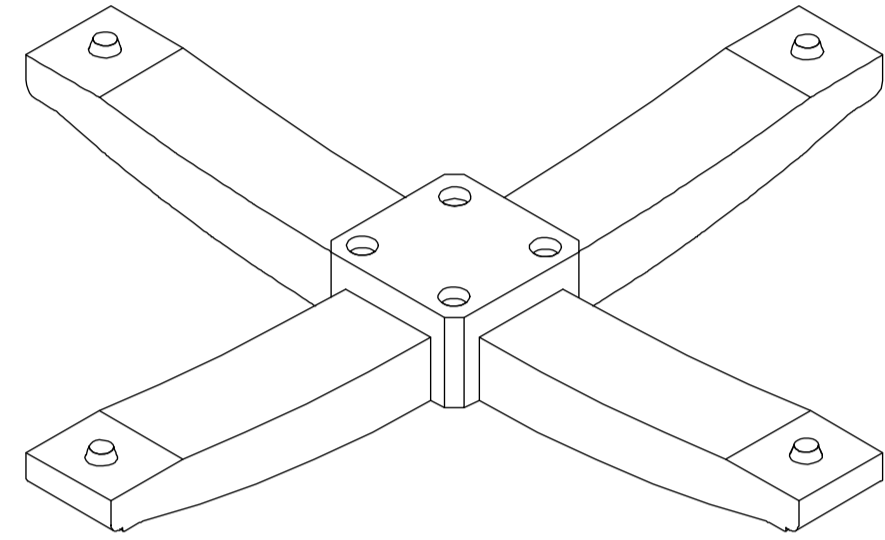

1 PC

E Pedestal Column

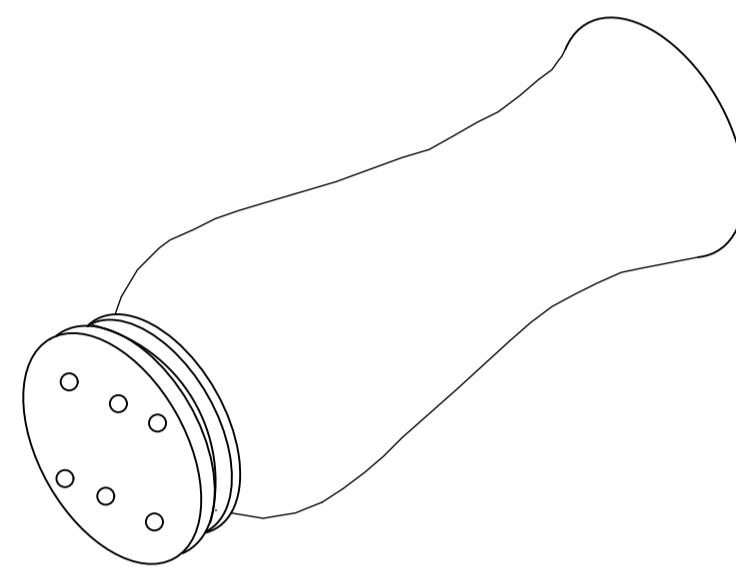

1 PC

F Bolt
Ø1/4" x 70mm

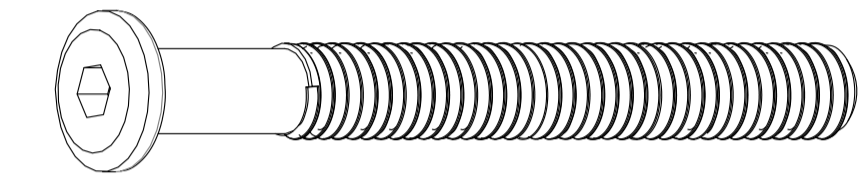

8 PCS

G Spring Washer
Ø1/4" x Ø13mm x 2mm

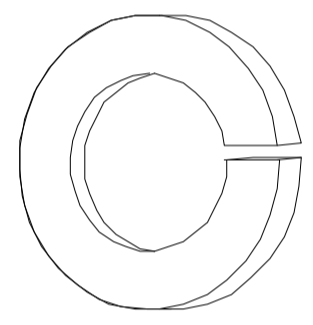

8 PCS

H Flat Washer
Ø1/4" x Ø19mm x 2mm

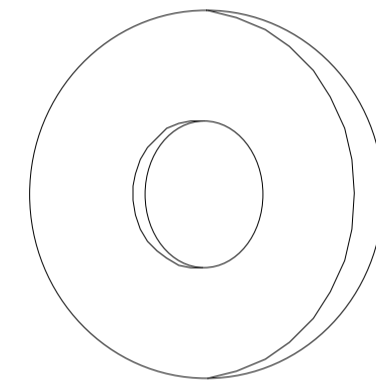

8 PCS

I Allen Wrench
4mm



1 PC

J Bolt
Ø5/16" x 35mm

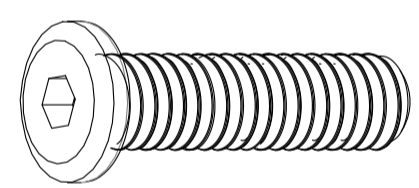

8 PCS

K Spring Washer
Ø5/16" x Ø13mm x 2mm

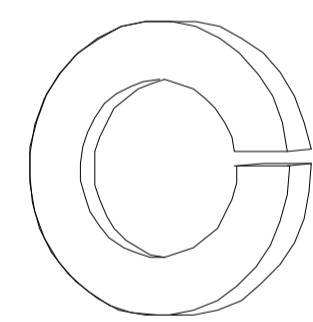

8 PCS

L Flat Washer
Ø5/16" x Ø19mm x 2mm

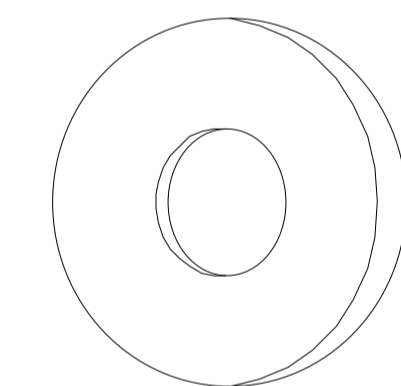

8 PCS

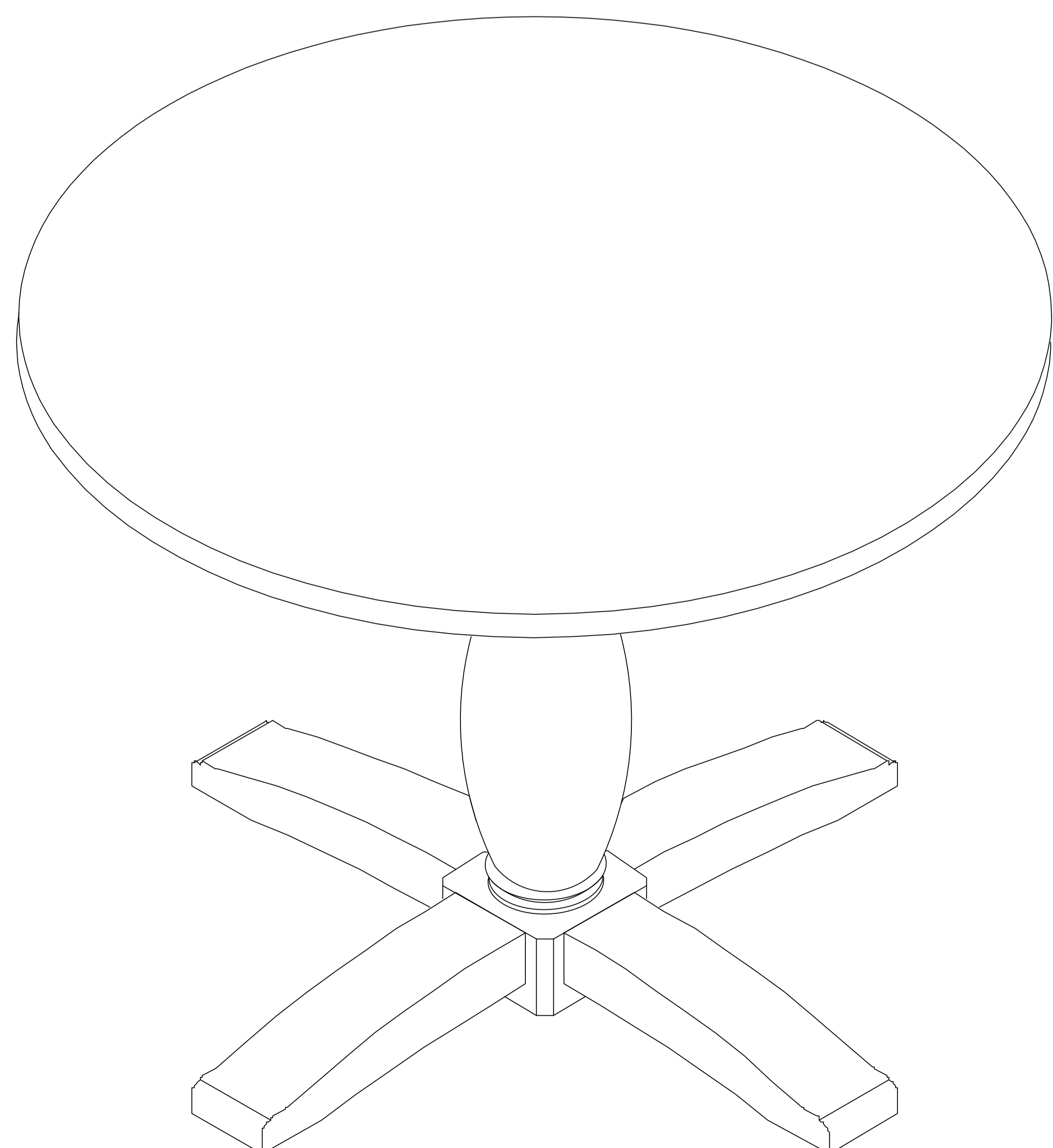

This page lists all the contents included in the box. Please take the time to identify the hardware as well as the individual components to this product. As you unpack and prepare for assembly, place the contents on a carpeted or padded area to protect them from damage.

1 Attach Table Base (D) to Pedestal Column (E) using Bolt (F), Spring Washer (G) and Flat Washer (H) with Allen Wrench (I).

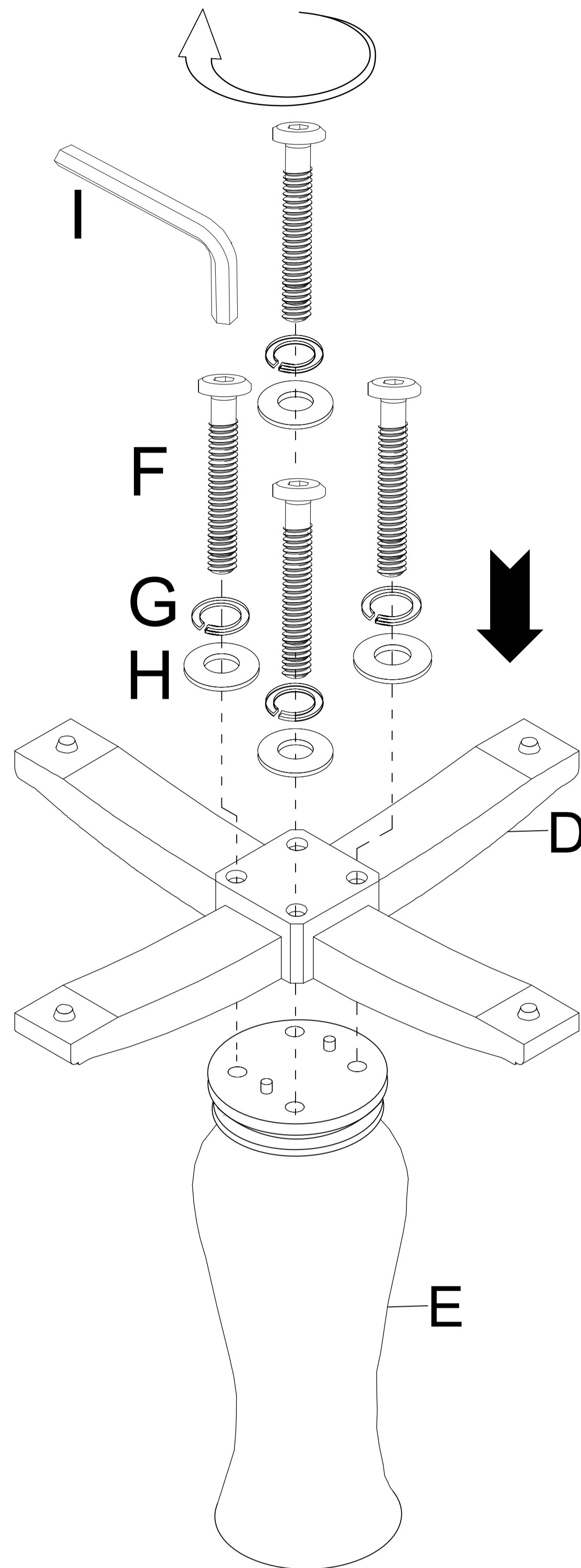

2 Attach Table Top Cross Base (B) to Pedestal Column (E) using Bolt (F), Spring Washer (G) and Flat Washer (H) with Allen Wrench (I).

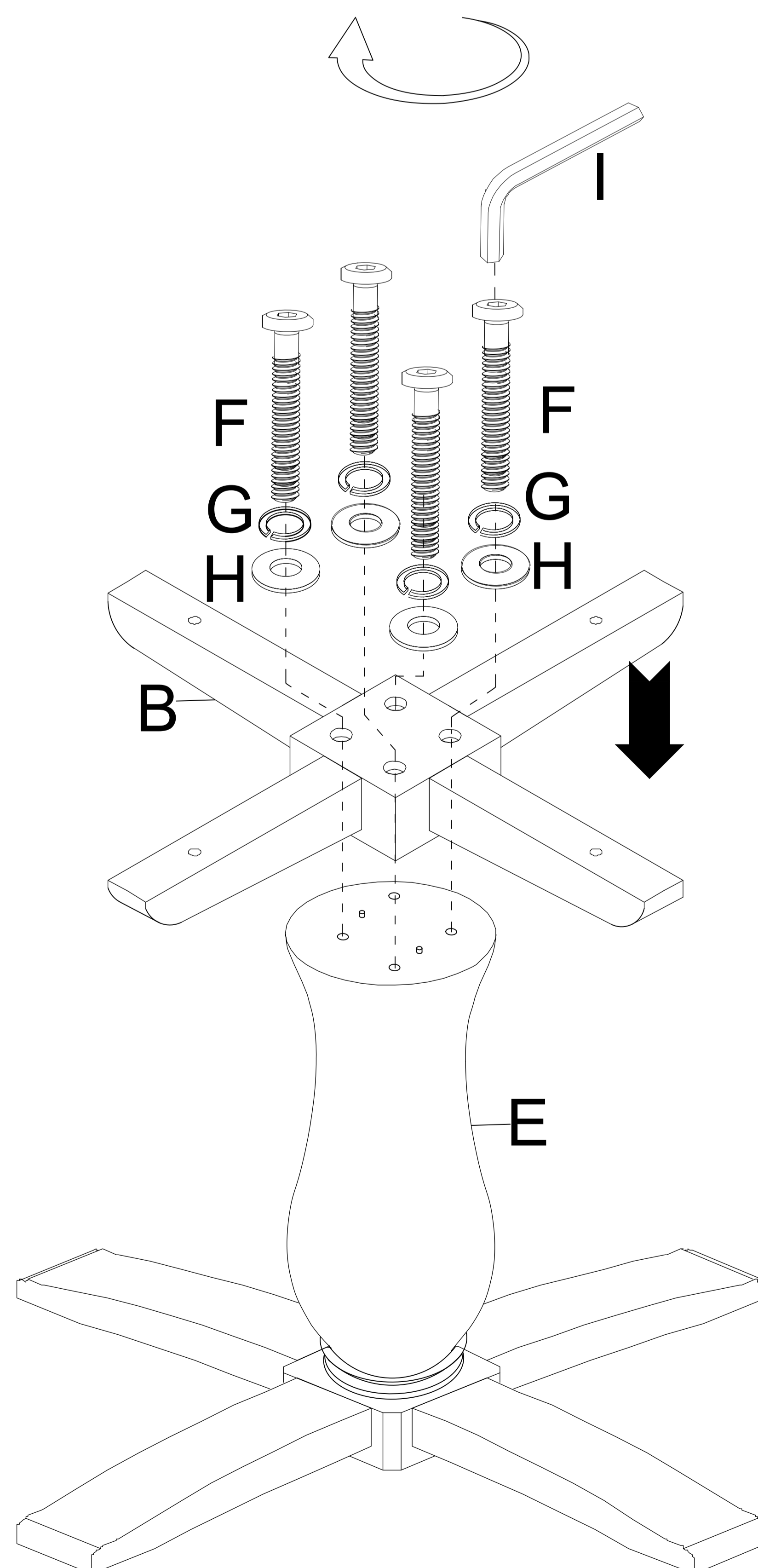

- 3** Detach Connecting Plate (C) from Table Top (A) by unfastening the bolts, spring washers and flat washers with Allen Wrench (I). Then attach Connecting Plate (C) to Table Top Cross Base (B) using Bolt (J), Spring Washer (K) and Flat Washer (L) with Allen Wrench (I).

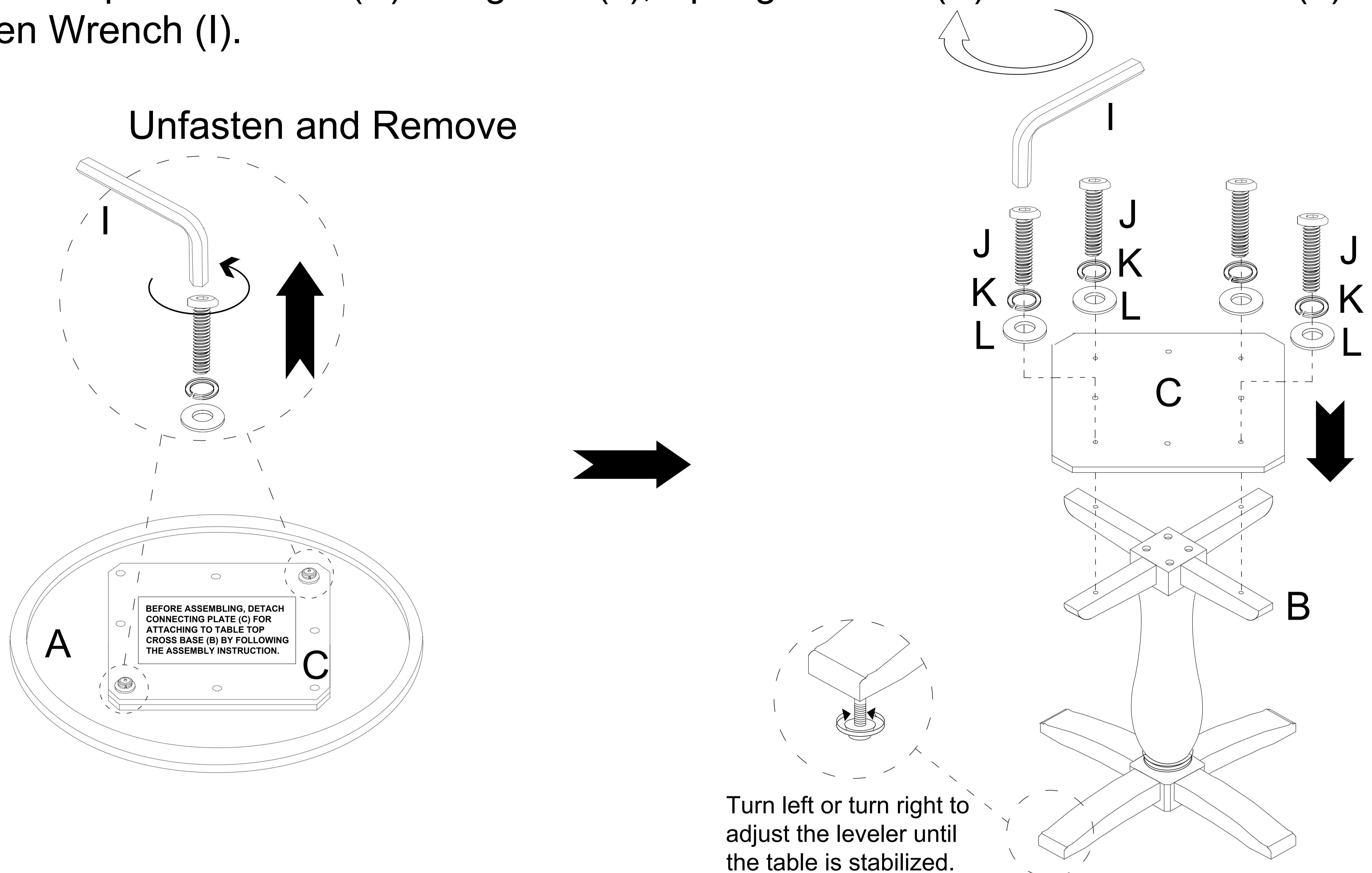

- 4** Attach Connecting Plate (C) to Table Top (A) using Bolt (J), Spring Washer (K) and Flat Washer (L) with Allen Wrench (I).

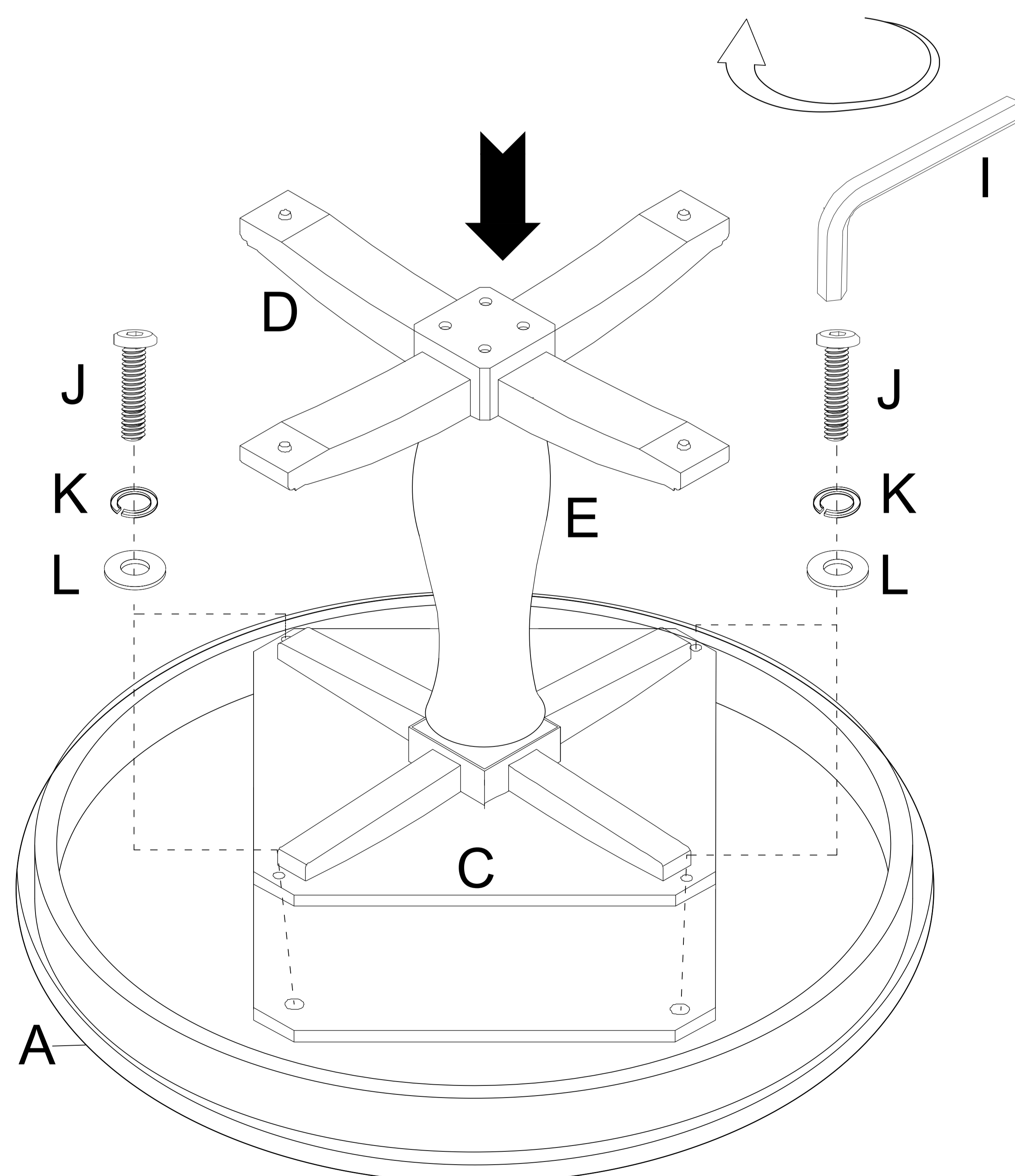

Cleaning & Care

Treat surfaces with care. Surfaces are resistant to scratches but are not scratch resistant. Clean surfaces with a dry or damp soft cloth. Do not use abrasive cleaners. Hardware may loosen over time. Periodically check that all connections are tight.

ASSEMBLY INSTRUCTION

DINING CHAIR

A Back Leg Frame

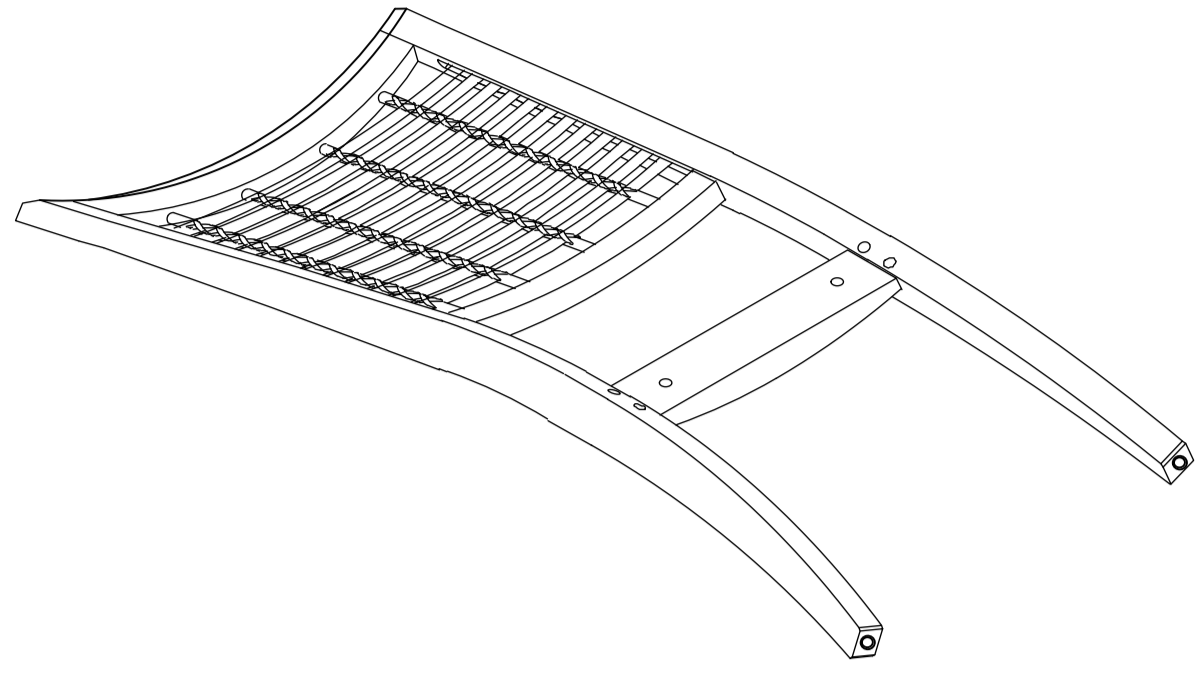

1 PC

B Seat Frame Cushion

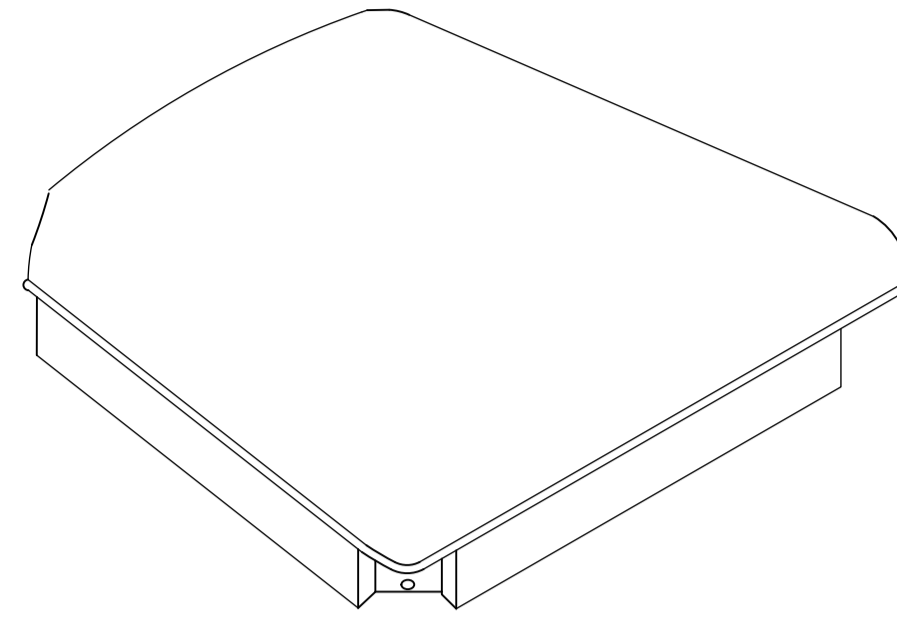

1 PC

C Front Leg

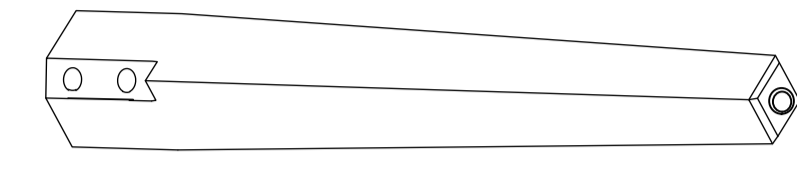

2 PCS

D Bolt
Ø1/4" x 70mm

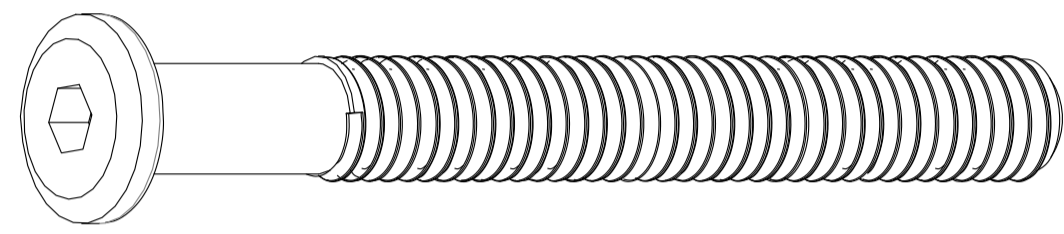

8 PCS

G Flat Washer
Ø1/4" x Ø19mm x 2mm

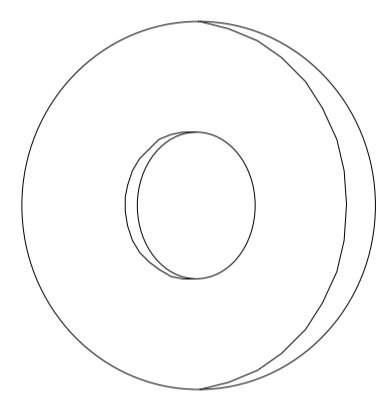

10 PCS

E Bolt
Ø1/4" x 45mm

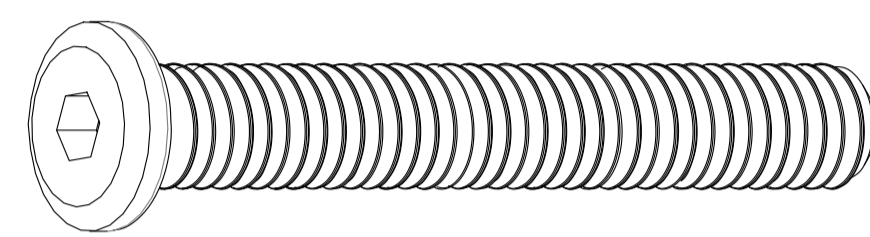

2 PCS

H Allen Wrench
4mm



1 PC

F Spring Washer
Ø1/4" x Ø13mm x 2mm

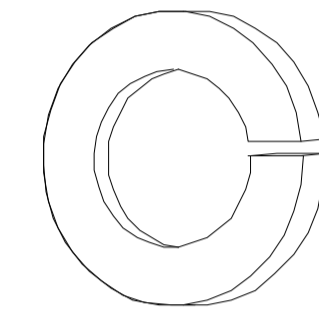

10 PCS

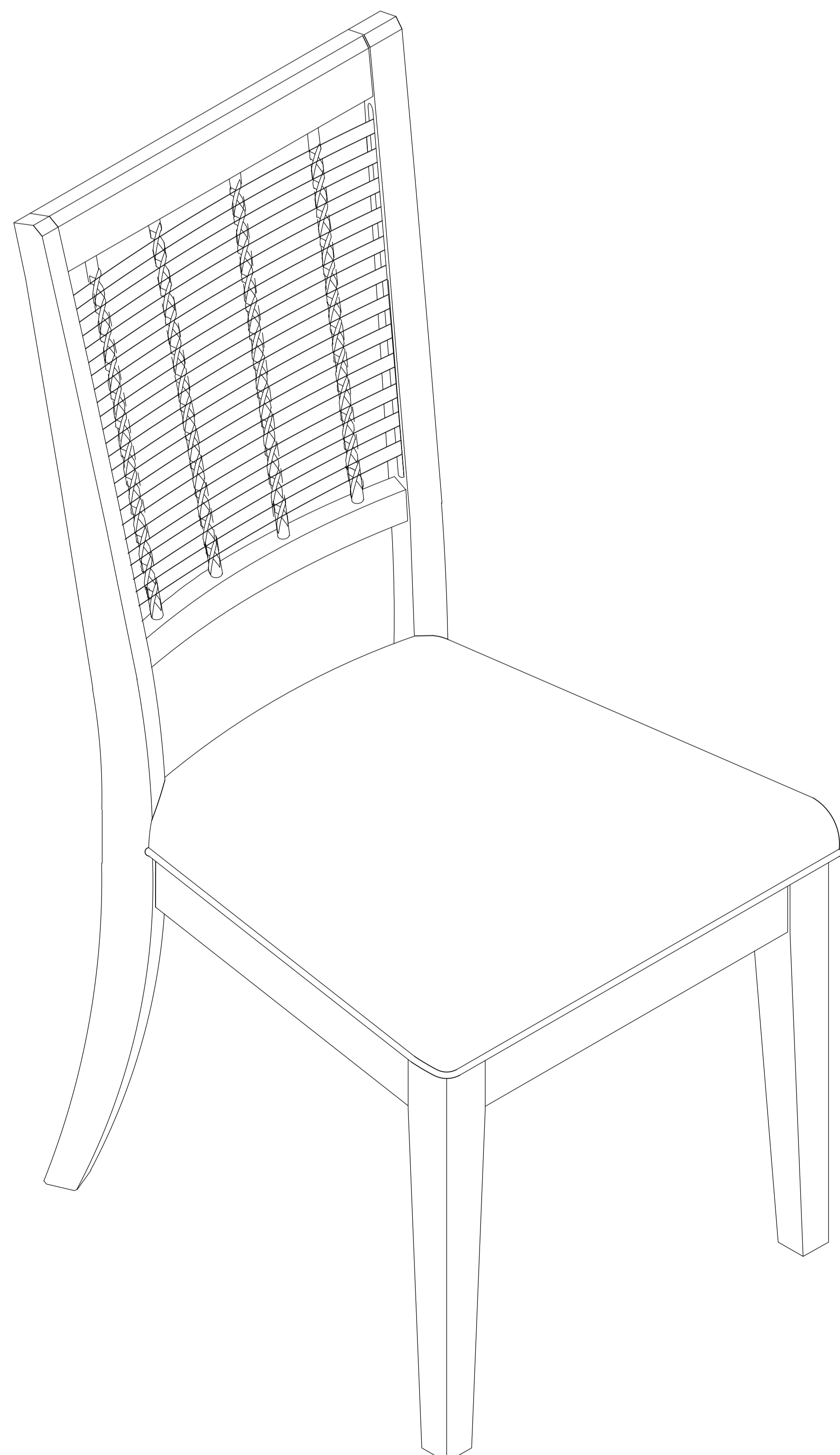

This page lists all the contents included in the box. Please take the time to identify the hardware as well as the individual components to this product. As you unpack and prepare for assembly, place the contents on a carpeted or padded area to protect them from damage.

- 1** Attach Seat Frame Cushion (B) to Back Leg Frame (A) using Bolt (D & E), Spring Washer (F) and Flat Washer (G) with Allen Wrench (H). Do not fully tighten the bolts in this step.

Take the Allen Wrench and turn the bolts until the legs are secured. **DO NOT TIGHTEN THE BOLTS COMPLETELY.** Stop when you feel you are adding force to tighten the bolt.

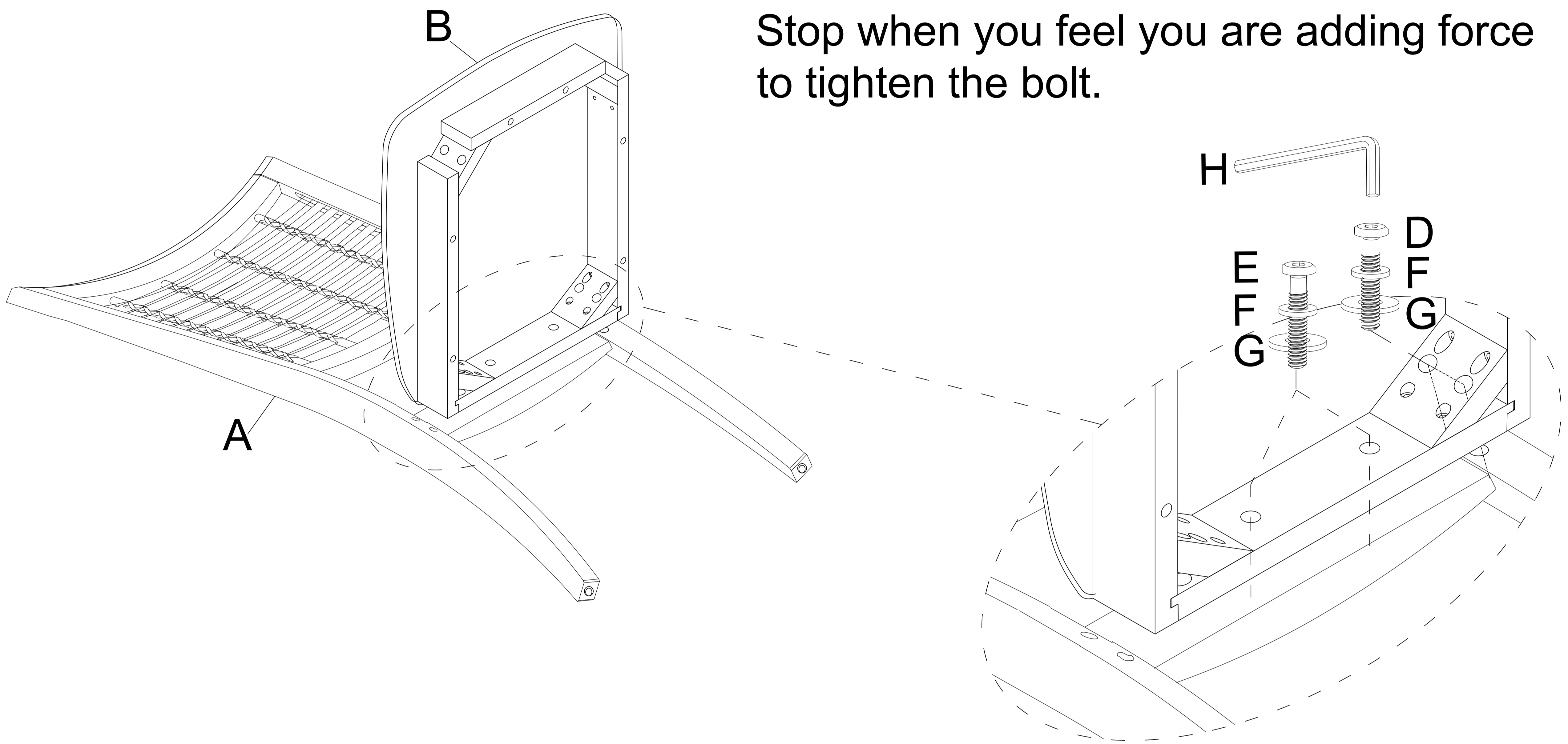

- 2** Attach Front Leg (C) to Seat Frame Cushion (B) using Bolt (D), Spring Washer (F) and Flat Washer (G) with Allen Wrench (H). Fully tighten all the bolts in this step.

Stand up the chair on an even surface and check that it is balanced. If the chair has a slight wobble, apply downward pressure on the uneven leg and tighten all bolts to fix the imbalance. If the chair is now balanced, apply downward pressure evenly in the center of the chair and tighten all bolts. Do not over-tighten beyond hole depth.

Helpful Tip: Have someone sit in the chair while tightening the bolts from underneath.

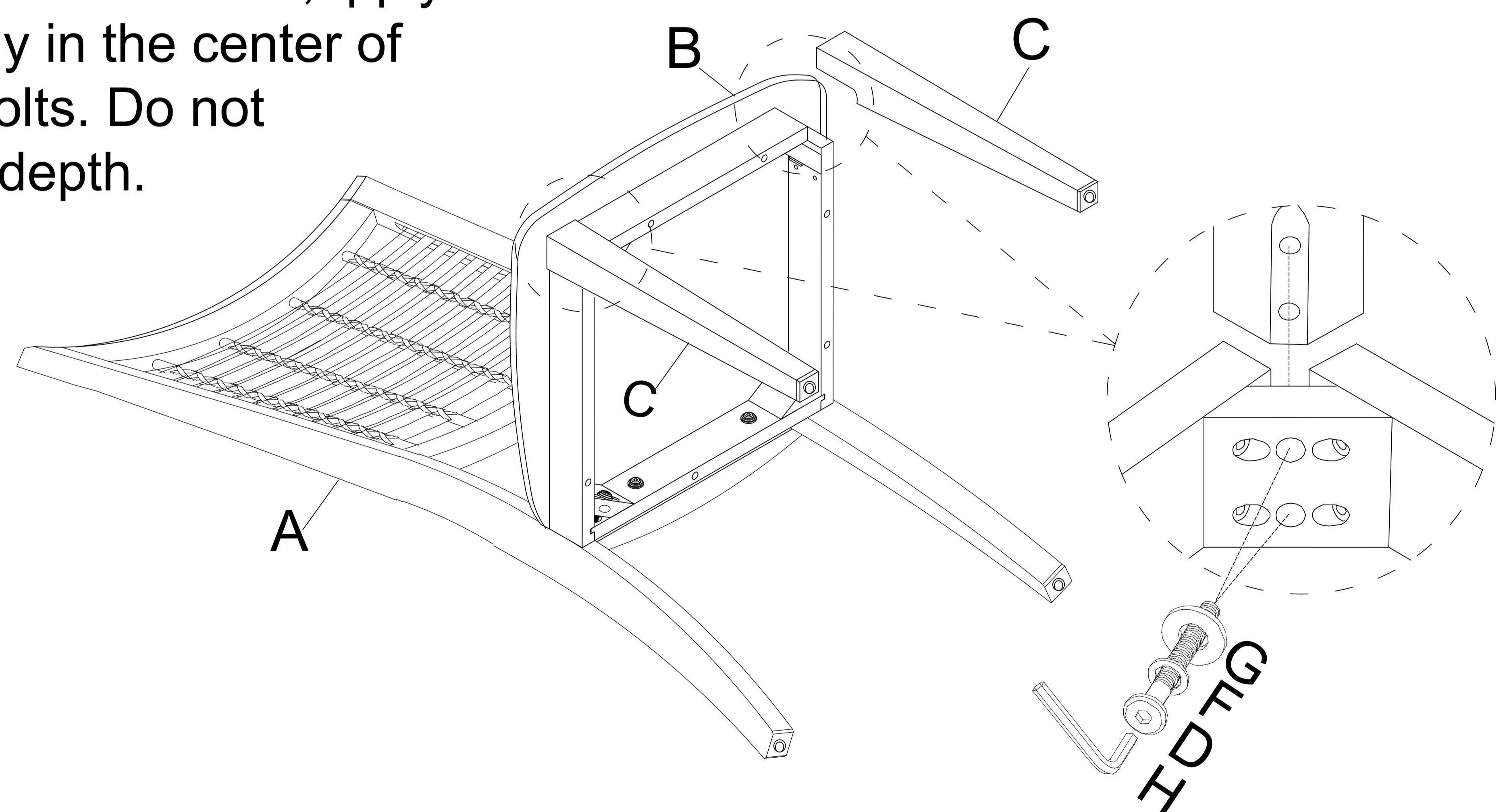

Cleaning & Care

Treat surfaces with care. Surfaces are resistant to scratches but are not scratch resistant. Clean surfaces with a dry or damp soft cloth. Do not use abrasive cleaners. Hardware may loosen over time. Periodically check that all connections are tight.