









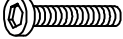

ASSEMBLY INSTRUCTION

METAL SUPPORTS COCKTAIL TABLE WITH FUNCTIONAL

WHEELS

| | | | |
|---|--|--|--|
| A Table Top  1PC | B Wheel Device  2PCS | C Small Caster  2PCS | D Big Caster  2PCS |
| E Wheel Axle  1PC | F Bolt 5/16"X1-1/2"  8PCS | G Flat Washer Ø27mm  4PCS | H Spring Washer 5/16"  8PCS |
| I Allen key 5mm  1PC | J Spanner 19mm  1PC | K Washer  2PCS | |

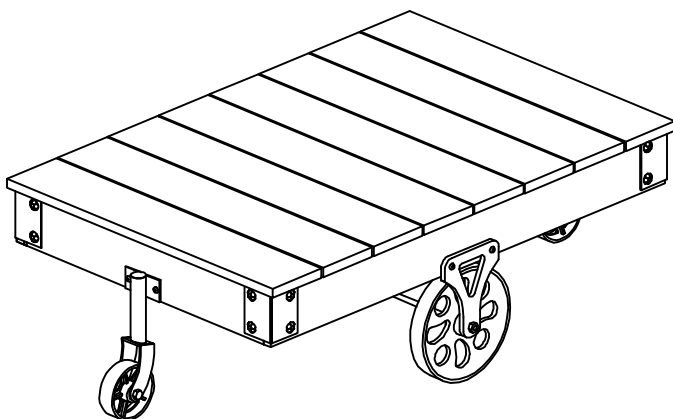

This page lists all the contents included in the box. Please take the time to identify the hardware as well as the individual components to this product. AS you unpack and prepare for assembly, place the contents on a carpeted or padded area to protect them from damage.

- 1** Attach the Wheel Device (B) to the Table Top (A) by using Spring Washer (H) and Bolt (F) with Allen Key (I).

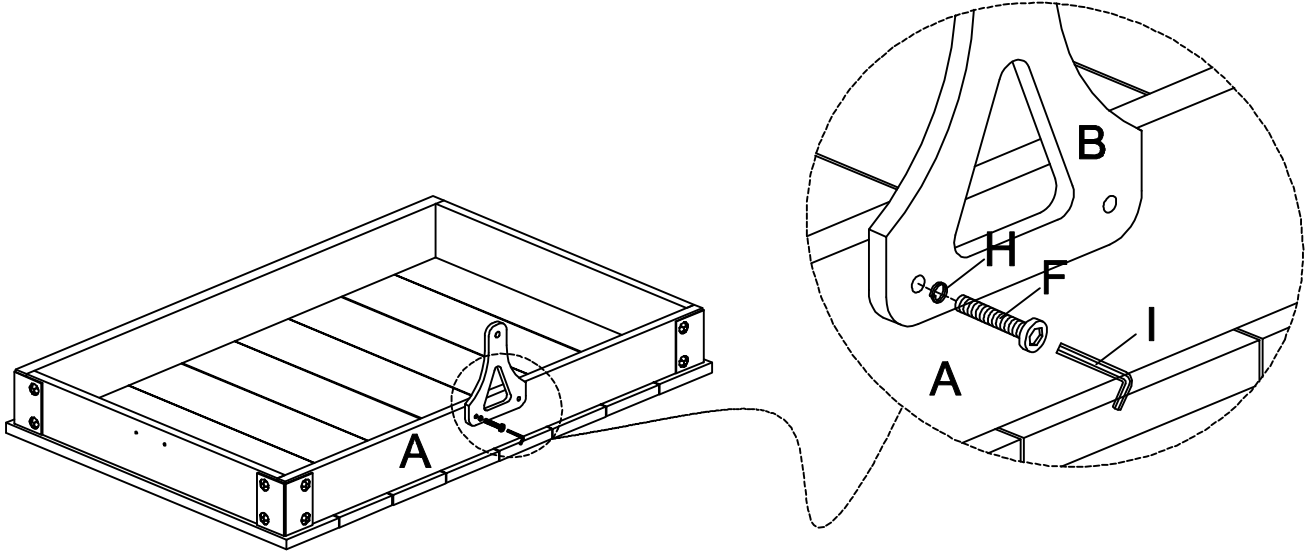

- 2** The Wheel Axle (E) with Flat Washer (G) is inserted to the Big Caster (D) with Flat Washer (G) and then attached to the Wheel Device (D) by using Washer (K) with Spanner (J).

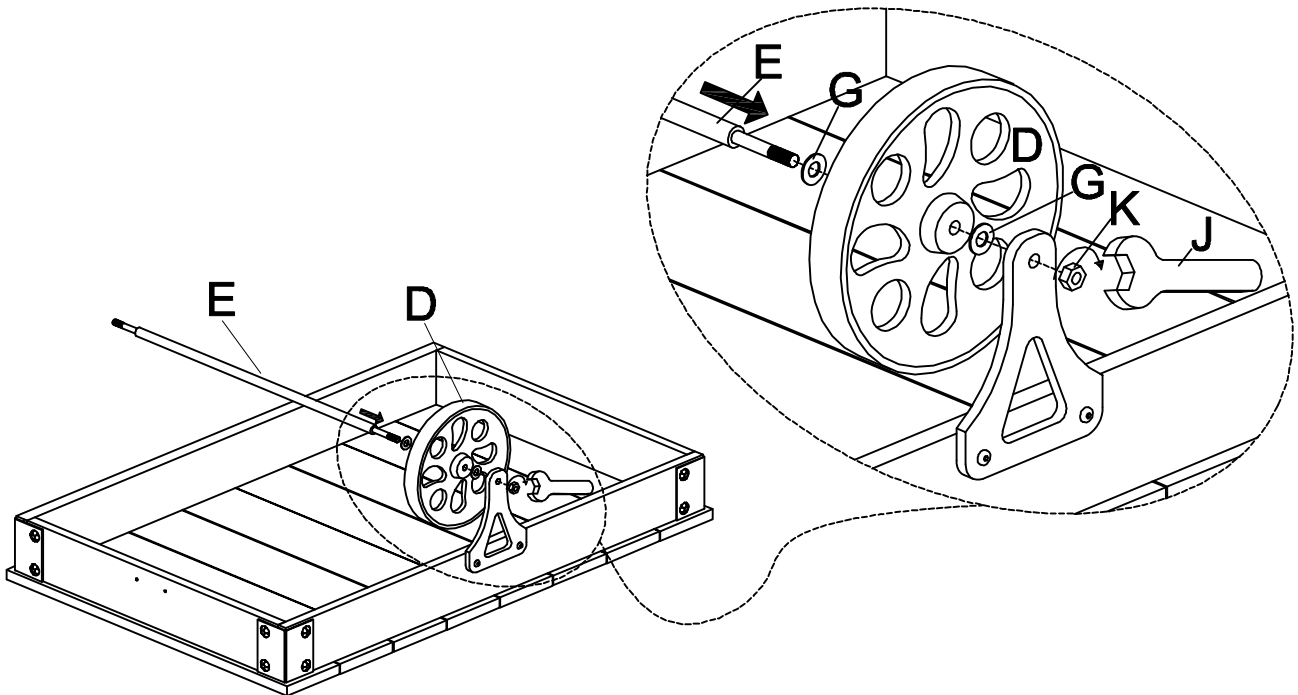

3 Attach the Big Caster (D) with Flat Washer (G) as below showing to the Wheel Axle (E).

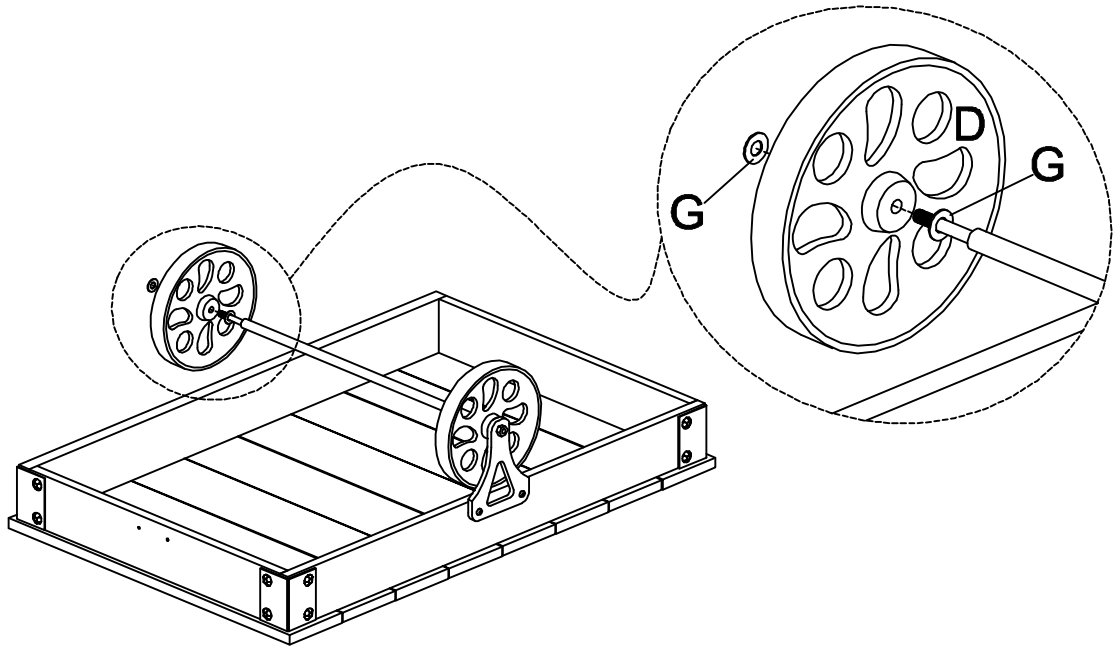

4 Attach the Big Caster (D) and Wheel Axle (E) as below showing to the Wheel Device (B) by using Washer (K) with Spanner (J), and then fixing the Wheel Device (B) to the Table Top (A) by using Spring Washer (H) and Bolt (F) with Allen Key (I).

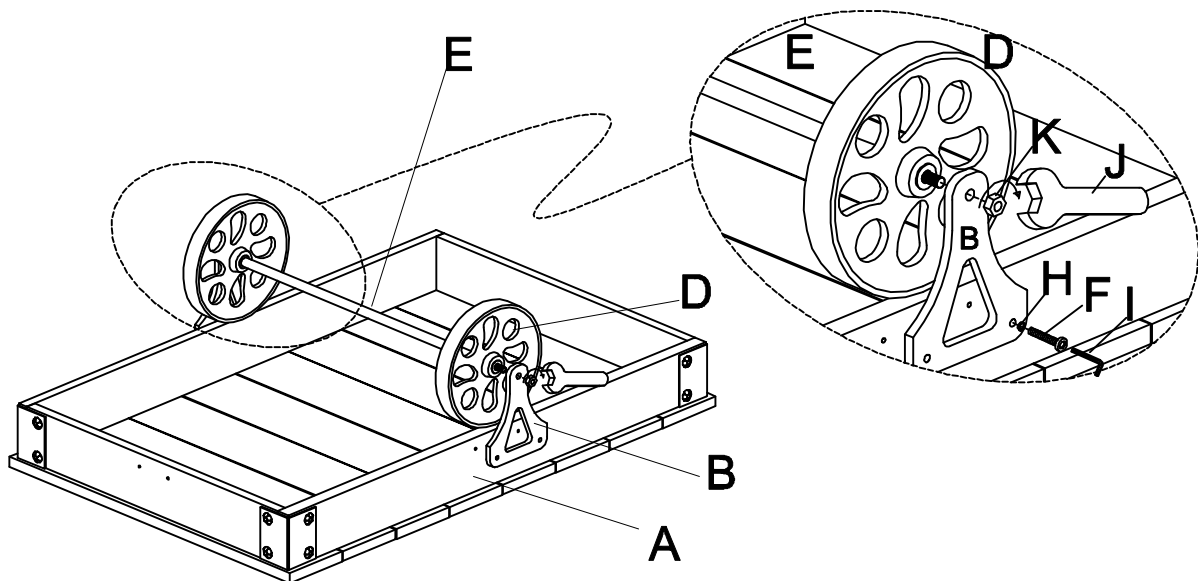

-
- 5** Attach the Small Caster (C) to the Table Top (A) by using Spring Washer (H) and Bolt (F) with Allen Key (I).

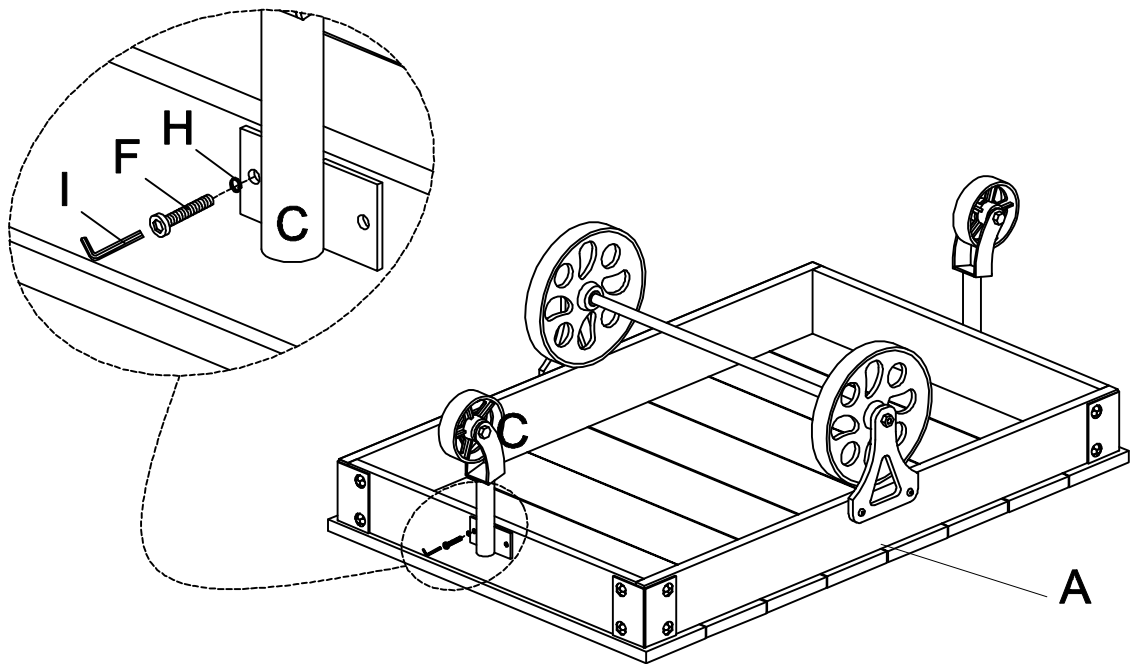

Cleaning & Care

Treat surface with care. Surface is resistant to scratches but is not scratch resistant. Clean surfaces with a dry or damp soft cloth. Do not use abrasive cleaners. Hardware may loosen over time. Periodically check that all connections are tight.