

# ASSEMBLY INSTRUCTION

## ROLLED TOP TUFTED CHAIR

**A** Chair Back

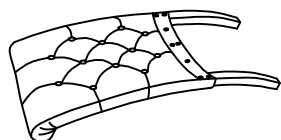

1pc

**B** Seat

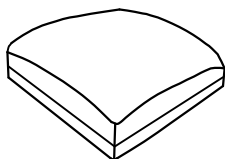

1pc

**C** Front Leg

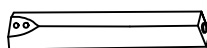

2pcs

**D** Lock Washer



11pcs

**E** Flat Washer

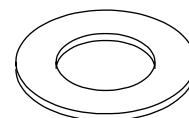

11pcs

**F** Bolt  
5/16"x3-1/2"

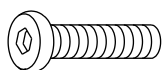

4pcs

**G** Bolt  
5/16"x2-1/2"

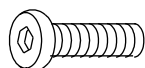

4pcs

**H** Bolt  
5/16"x2"

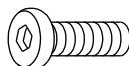

3pcs

**I** Allen Wrench



1pc

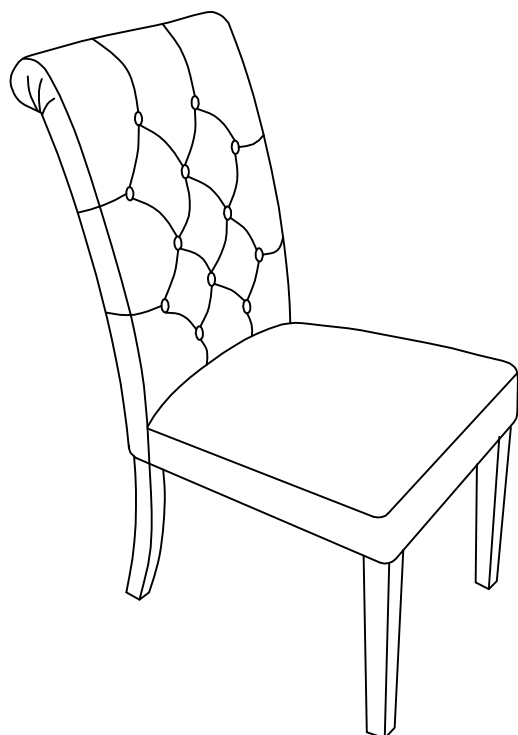

This page lists all the contents included in the box. Please take the time to identify the hardware as well as the individual components to this product. As you unpack and prepare for assembly, place the contents on a carpeted or padded area to protect them from damage.

**1**

Put the seat (B) on a smooth flat surface, attached one front leg (C) to the seat (B) use bolt (G), lock washer (D) and flat washer (E) on both of hole of seat. Turn the allen wrench (I) in bolt (G). But not too tight.

Take the Allen Wrench, and turn the bolts until the legs are secure.  
**DO NOT TIGHTEN COMPLETELY.**  
 Stop when you feel you are adding force to tighten the bolt.

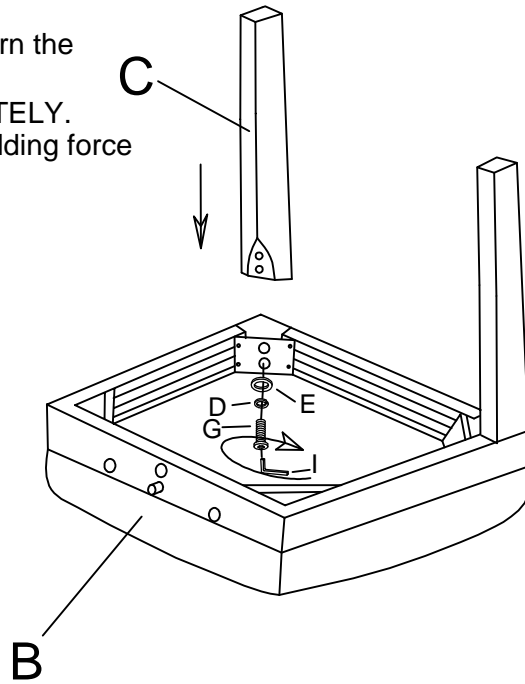
**2**

Put chair back (A) on a smooth flat surface, attached the seat (B) the chair back (A) use the bolt (F), lock washer (D), flat washer (E) in both of hole of seat (B) and chair back (A), turn the allen wrench (I) in bolt (F). But not too tight.

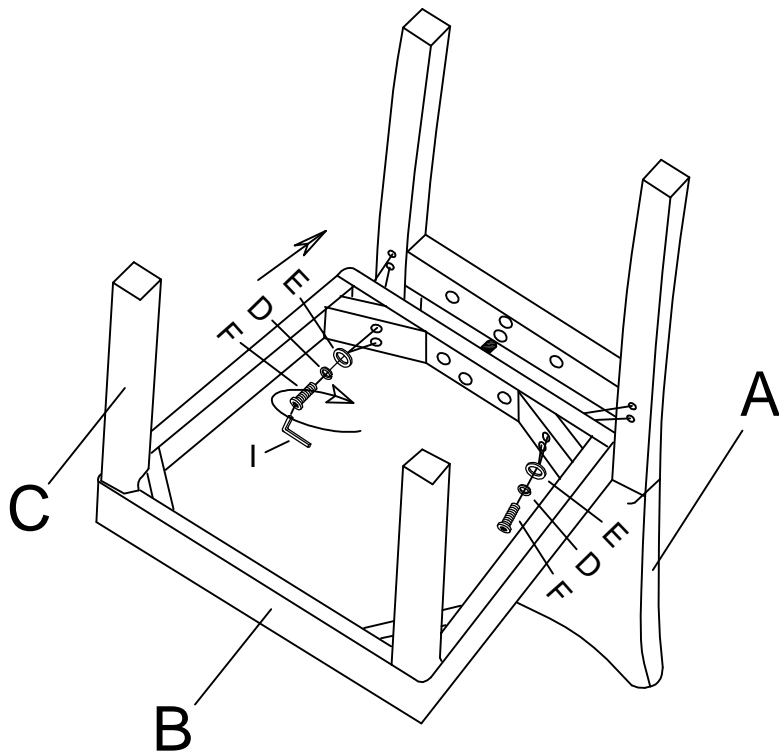

**3**

Use the bolt (H), lock washer (D), flat washer (E) in both of hole of seat (B) and chair back (A), turn the allen wrench (I) to tighten the bolt (H).

Stand chair up on an even surface and check that it is balanced.  
If there is a slight wobble, apply downward pressure in the corner where a leg is uneven. Keeping pressure in that corner, tighten all bolts.  
If balanced, apply downward pressure evenly in the center and tighten all bolts.  
Do not over-tighten beyond hole depth.

Helpful Tip:  
-Instead of applying downward pressure while reaching under to tighten bolts, have someone sit in the chair while you tighten the bolts.

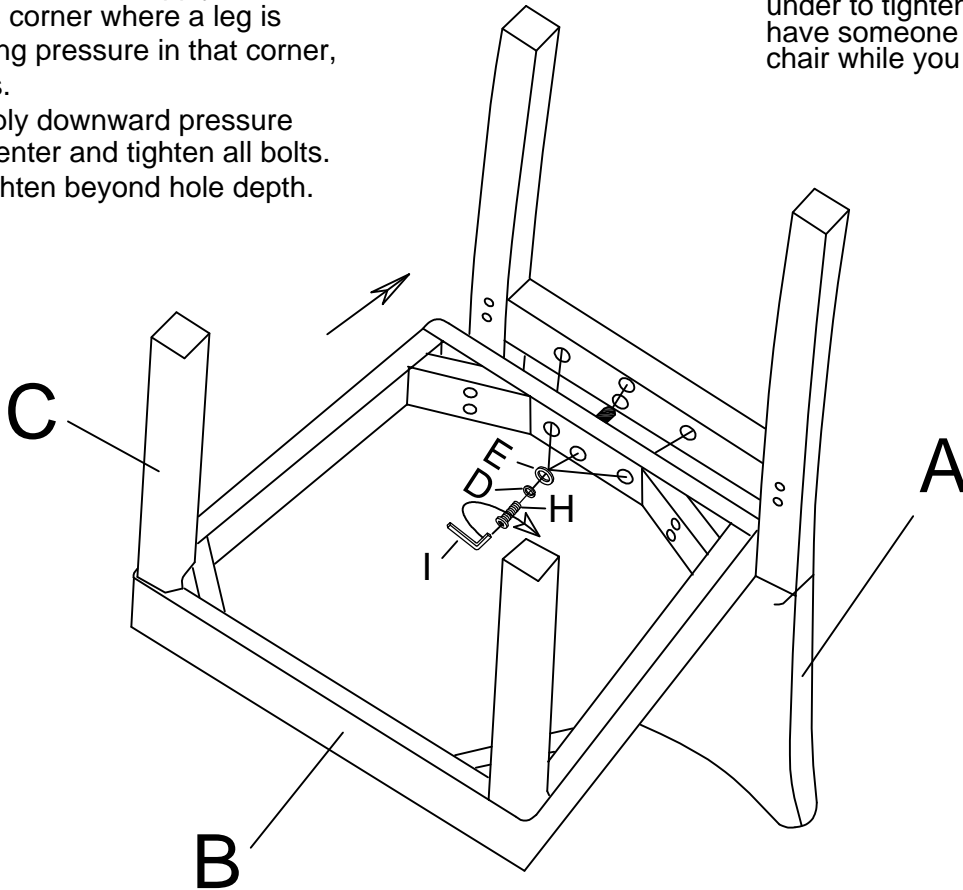

### Cleaning & Care

Treat surface with care. Surface is resistant to scratches but is not scratch resistant. Clean surfaces with a dry or damp soft cloth. Do not use abrasive cleaners. Hardware may loosen over time. Periodically check that all connections are tight.