

# *ASSEMBLY INSTRUCTIONS*



***3PC OCCASIONAL SET***

# ASSEMBLY INSTRUCTIONS

## ASSEMBLY TIPS:

1. Remove hardware from box and sort by size.
2. Please check to see that all hardware and parts are present prior to start of assembly.
3. Please follow attached instructions in the same sequence as numbered to assure fast & easy assembly.



### WARNING!





1. Don't attempt to repair or modify parts that are broken or defective. Please contact the store immediately.
2. This product is for home use only and not intended for commercial establishments.





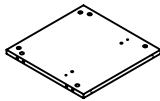
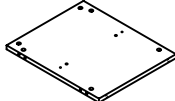

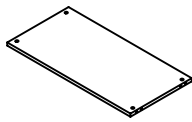
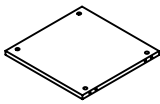
ASSEMBLY TIME

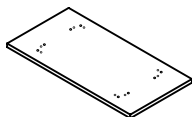
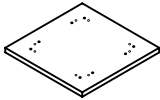
60 MINUTES

## PARTS IDENTIFICATION

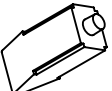
A	SHORT SIDE PANEL		2PCS	F	LONG SIDE PANEL		4PCS
B	LEFT SHORT PANEL		2PCS	G	LEFT LARGE PANEL		4PCS
C	LARGE SHELF		1PC	H	SMALL SHELF		2PCS
D	RIGHT SHORT PANEL		2PCS	I	RIGHT LARGE PANEL		4PCS
E	LARGE TOP PANEL		1PC	J	SMALL TOP PANEL		2PCS

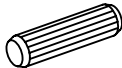
## HARDWARE IDENTIFICATION

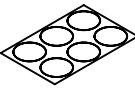
Z	NO	DESCRIPTION	FIGURE	Q'TY	NO	DESCRIPTION	FIGURE	Q'TY
	1	GLUE 40g		1PC	4	CAM BOLT Ø 7x35.5mm SR		60PCS
	2	WOODEN DOWEL Ø 8x30mm		60PCS	5	PLASTIC FEET Ø 15mm		12PCS
	3	CAM LOCK Ø 15x12mm SR		60PCS	6	STICKER Ø 20mm		10PCS

### NOTE:

Phillips head screw driver is required in the assembly process; however, manufacturer does not provide this item.



## STEP 2

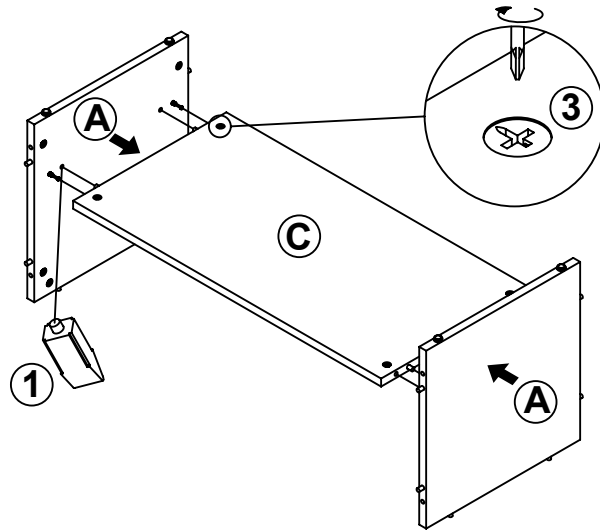

## STEP 3

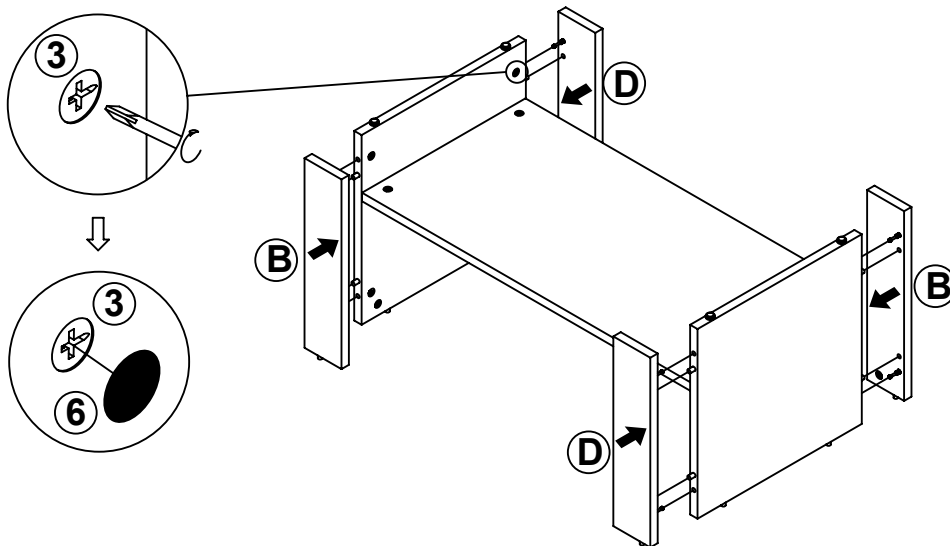

## STEP 4

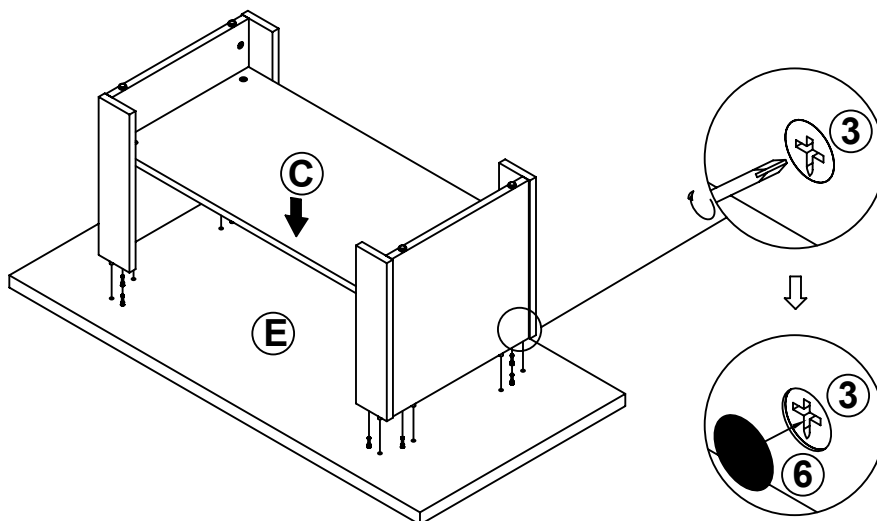

# STEP 5

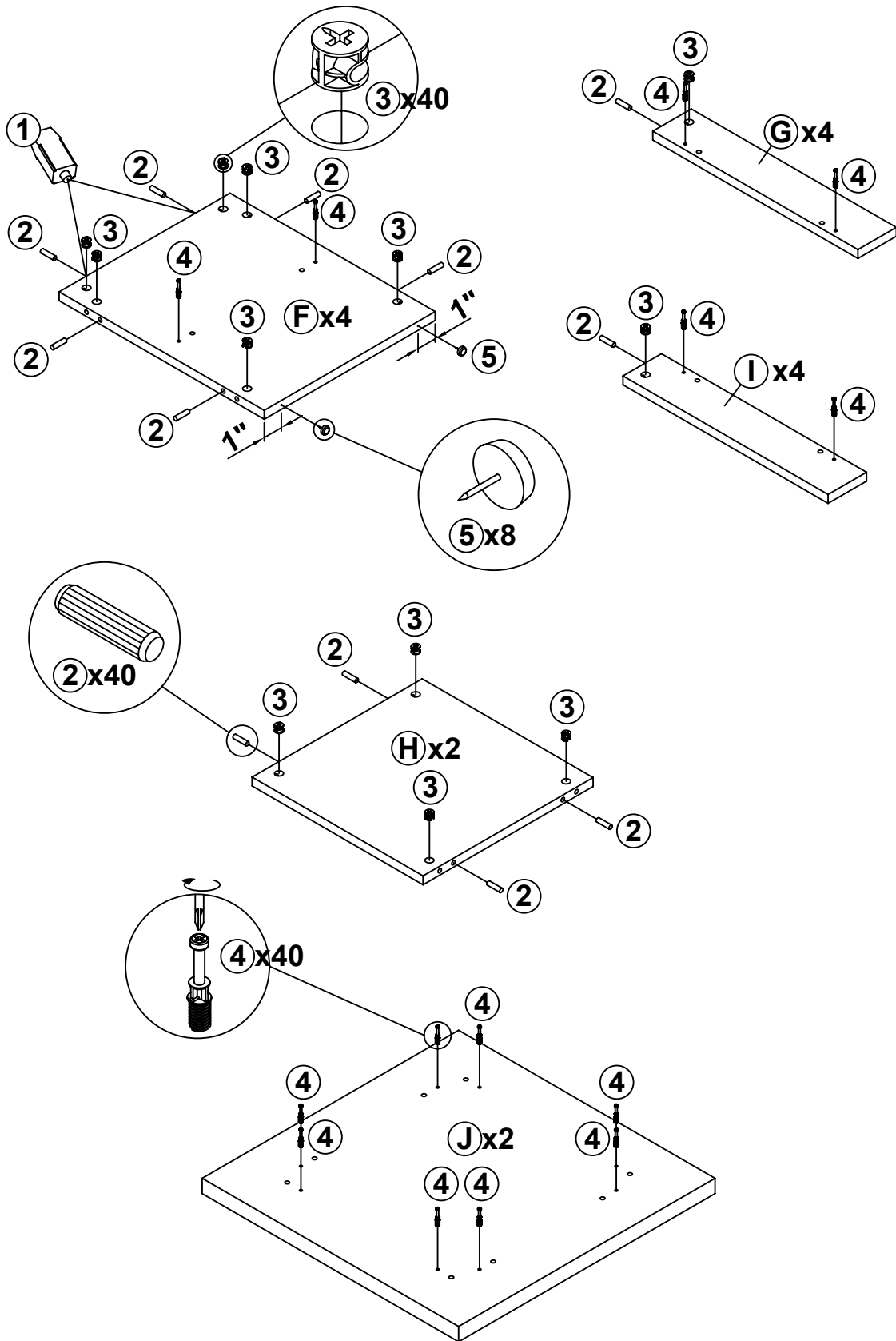

## STEP 6

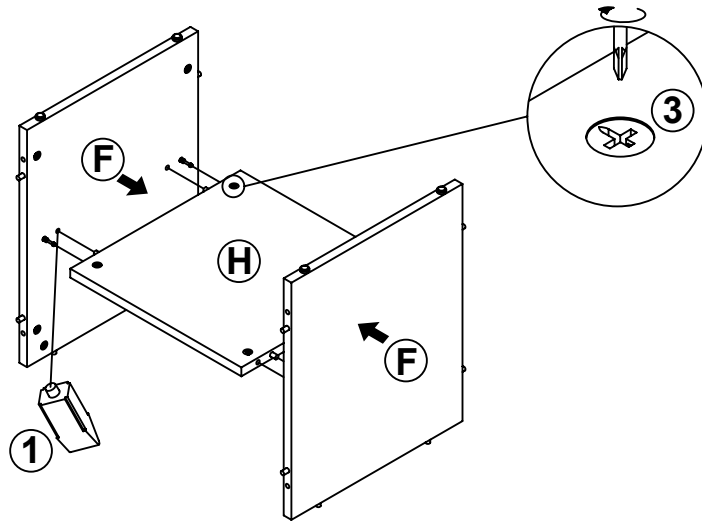

## STEP 7

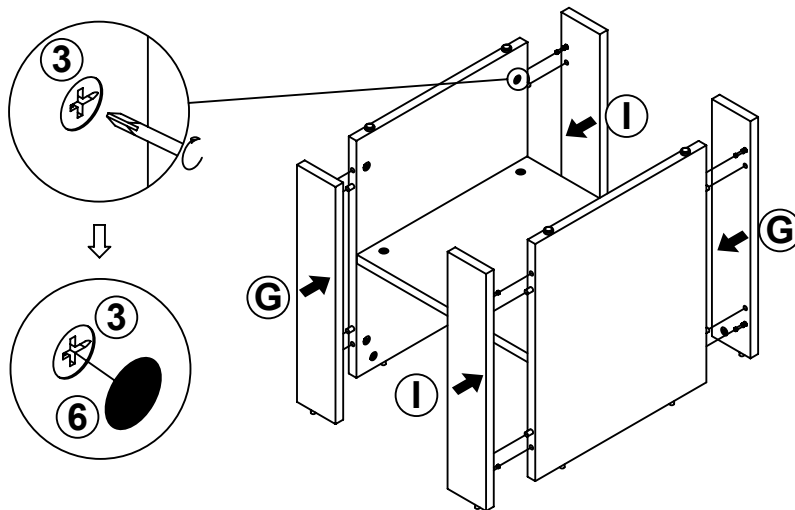

## STEP 8

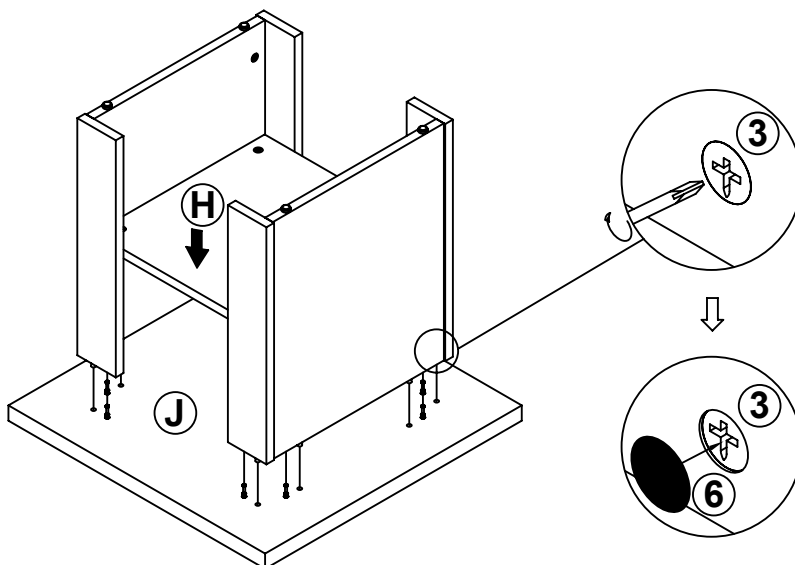

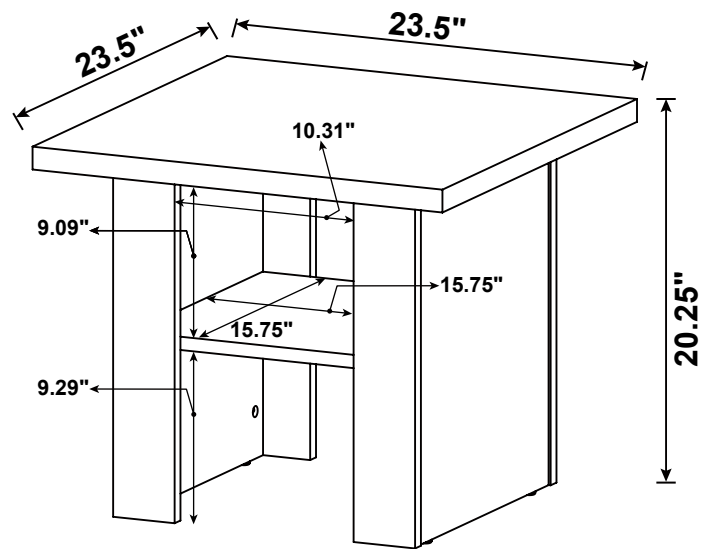
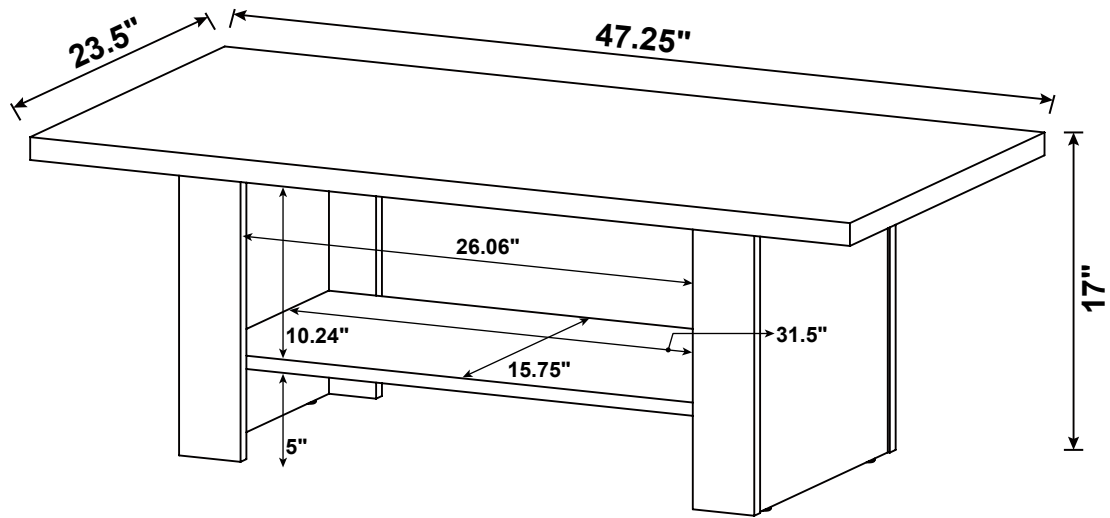

**Note :** Dimension tolerance  $\pm 5\%$