

ASSEMBLY INSTRUCTIONS & PARTS IDENTIFICATION

Parts List			
Item	Code	Description	Qty
A		Front legs	2pcs
B		Rear legs	2pcs

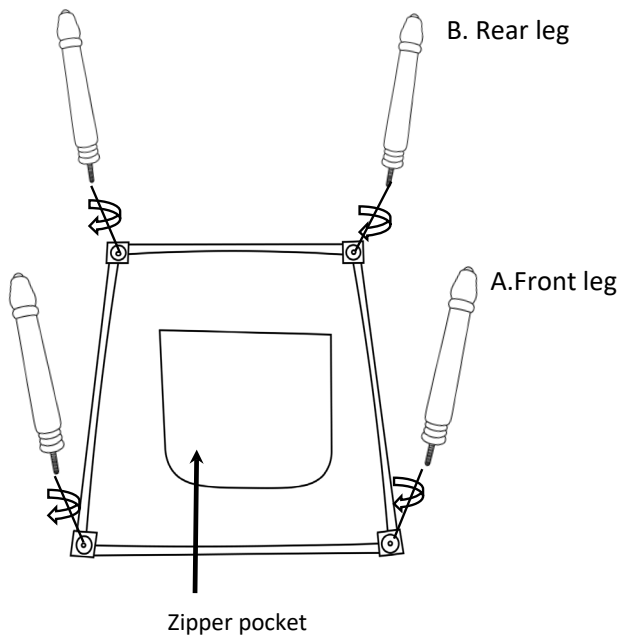
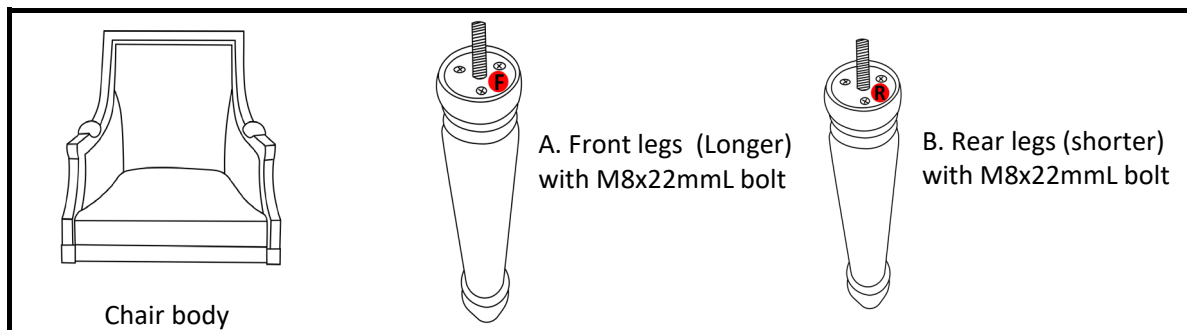
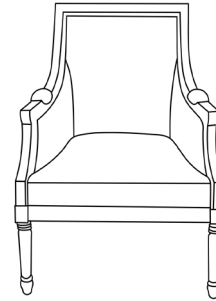

Assembly Steps:

- Step 1. Turn chair body over on a clean flat surface.
- Step 2. Remove legs from zippered pocket underneath chair.
- Step 3. Screw in front legs (item A) until they are hand tight.
- Step 4. Screw in rear legs (item B) until they are hand tight and in an outward position.
- Step 5. Turn chair to its upright position.

FABRIC CONTENT

88% polyester 12% cotton

***Cleaning Code: S

Professional cleaning recommended. Spot clean with a mild water-free solvent or dry cleaning product. Vacuum surface occasionally with an upholstery attachment. Avoid direct sunlight, water, oil, acid, sharp object etc. Do not clean with water or any