

"IMPORTANT, RETAIN FOR FUTURE REFERENCE: READ CAREFULLY"

German: WICHTIG, FÜR SPÄTERE NACHSCHLAGE AUFBEWAHREN: SORGFÄLTIG LESEN

Spanish: IMPORTANTE, GUARDAR PARA REFERENCIA FUTURA: LEER ATENTAMENTE

Italian: IMPORTANTE, CONSERVARE PER RIFERIMENTI FUTURI: LEGGERE ATTENTAMENTE

French: IMPORTANT, À CONSERVER POUR RÉFÉRENCE FUTURE : LIRE ATTENTIVEMENT



1. Periodically check that all components are tightly secured.
2. Assemble on a flat, clean, and soft surface.
3. Confirm all parts are present prior to assembly.
4. Prepare electric tools in advance for a quicker installation.







1. Prüfen Sie regelmäßig, ob alle Komponenten fest sitzen.
2. Montieren Sie das Gerät auf einer ebenen, sauberen und weichen Oberfläche.
3. Vergewissern Sie sich vor dem Zusammenbau, dass alle Teile vorhanden sind.
4. Bereiten Sie Elektrowerkzeuge im Voraus vor, um eine schnellere Installation zu ermöglichen.



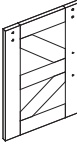

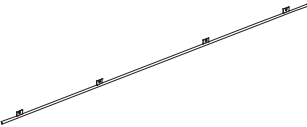
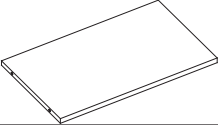
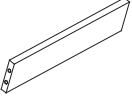
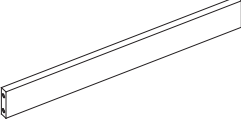
1. Vérifiez périodiquement que tous les composants sont bien fixés.
2. Assemblez le tout sur une surface plane, propre et douce.
3. Confirmez que toutes les pièces sont présentes avant l'assemblage.
4. Préparez les outils électriques à l'avance pour une installation plus rapide.

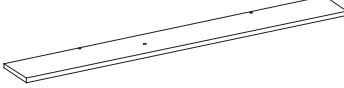



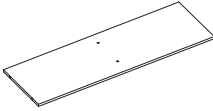
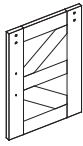
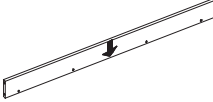
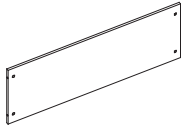
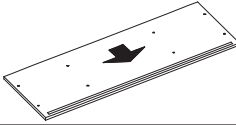
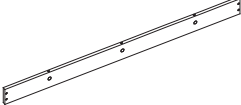
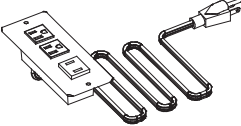

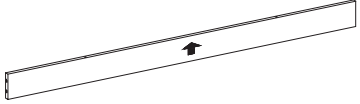

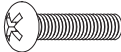
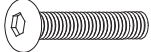

1. Controllare periodicamente che tutti i componenti siano fissati saldamente.
2. Assemblare su una superficie piana, pulita e morbida.
3. Assicurarsi che siano presenti tutte le parti prima dell'assemblaggio.
4. Preparare gli strumenti elettrici in anticipo per un'installazione più veloce.

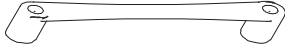
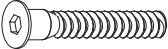
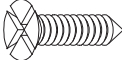
1. Revise que todos los componentes estén asegurados con regularidad.
2. Monte sobre una superficie que sea plana, limpia y suave.
3. Antes de montar el producto, revise que tenga todas las piezas a mano.
4. Para facilitar la instalación, prepare las herramientas eléctricas necesarias con tiempo.

Item no. Nr. N° d'article Articolo No. Artículo No.	Reference Image Referenzbild Image de référence Immagine di riferimento Imagen de referencia	Qty. Menge Qté. Qtà Cant.	Item no. Nr. N° d'article Articolo No. Artículo No.	Reference Image Referenzbild Image de référence Immagine di riferimento Imagen de referencia	Qty. Menge Qté. Qtà Cant.
1		X1	2		X1
3		X1	4		X1

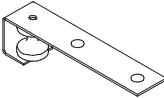
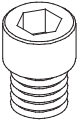
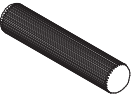
Item no. Nr. N° d'article Articolo No. Artículo No.	Reference Image Referenzbild Image de référence Immagine di riferimento Imagen de referencia	Qty. Menge Qté. Qtà Cant.
5		X1
7		X1
9		X2
11		X1
13		X1
15		X2
17		X2
19		X1
21		X1
23		X1

Item no. Nr. N° d'article Articolo No. Artículo No.	Reference Image Referenzbild Image de référence Immagine di riferimento Imagen de referencia	Qty. Menge Qté. Qtà Cant.
6		X1
8		X1
10		X1
12		X1
14		X1
16		X2
18		X1
20		X1
22		X2
24		X1

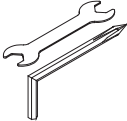
Item no. Nr. N° d'article Articolo No. Artículo No.	Reference Image Referenzbild Image de référence Immagine di riferimento Imagen de referencia	Qty. Menge Qté. Qtà Cant.	Item no. Nr. N° d'article Articolo No. Artículo No.	Reference Image Referenzbild Image de référence Immagine di riferimento Imagen de referencia	Qty. Menge Qté. Qtà Cant.
<b>A</b>	 M4*18mm	<b>X4</b>	<b>B</b>	 M6*23mm	<b>X12</b>
<b>C</b>		<b>X54</b>	<b>D</b>		<b>X2</b>
<b>E</b>	 M6.3*40mm	<b>X30</b>	<b>F</b>	 ST4*14mm	<b>X2</b>
<b>G</b>		<b>X12</b>	<b>H</b>		<b>X38</b>
<b>I</b>		<b>X16</b>	<b>J</b>		<b>X4</b>
<b>K</b>	 M6*16mm	<b>X4</b>	<b>L</b>		<b>X2</b>
<b>M</b>	 M6*25mm	<b>X2</b>	<b>N</b>	 M6*10mm	<b>X2</b>
<b>O</b>		<b>X5</b>	<b>P</b>		<b>X1</b>

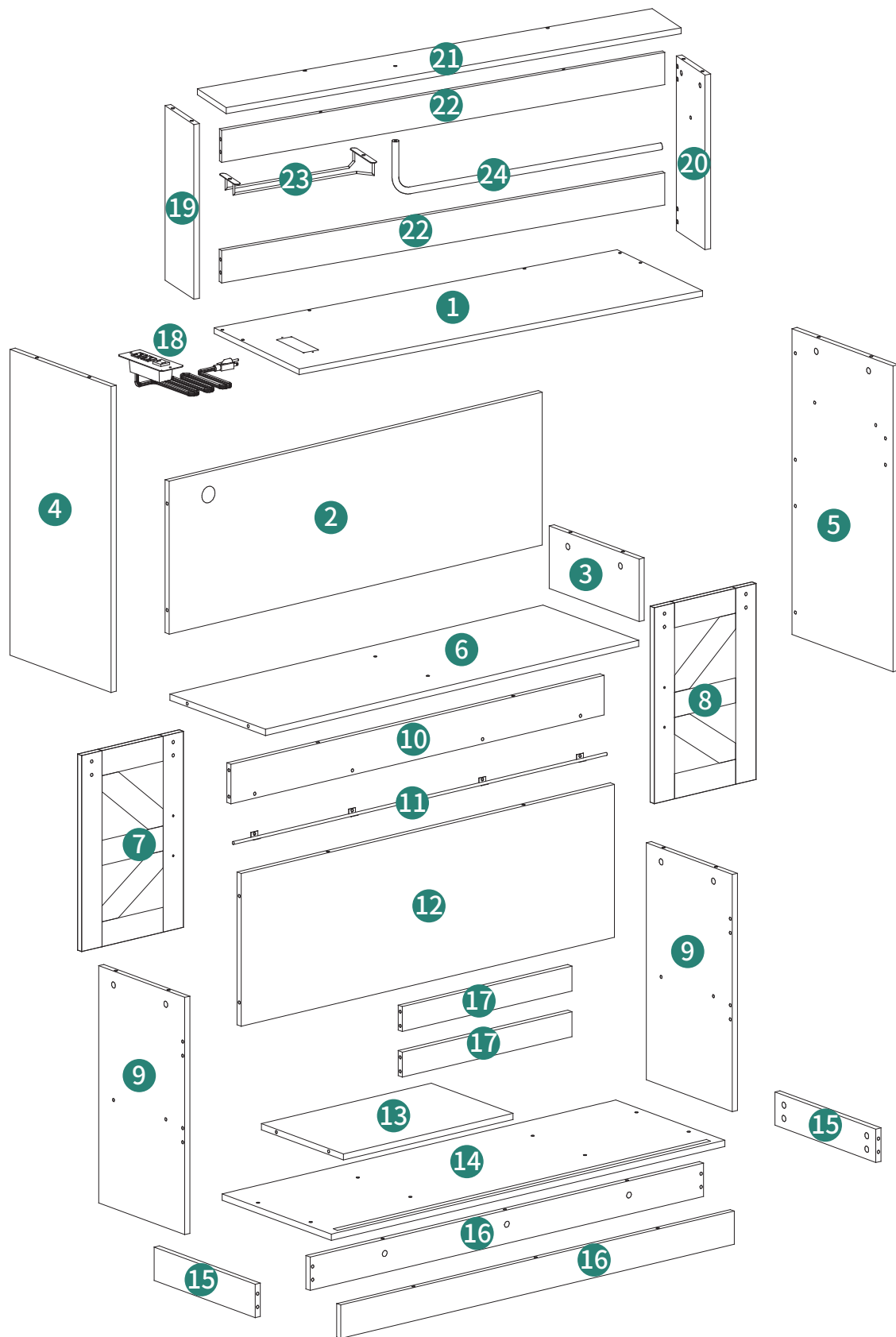

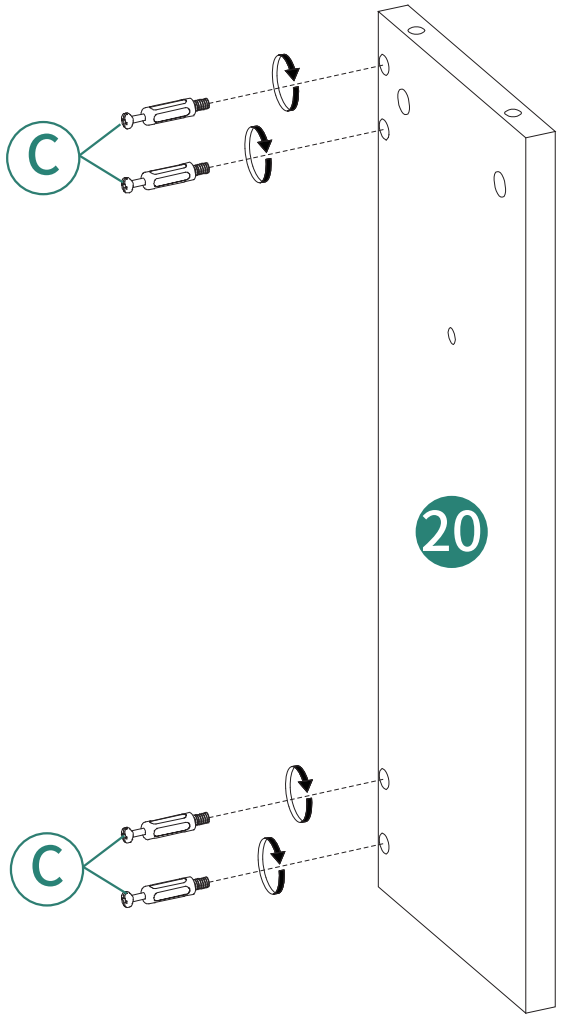
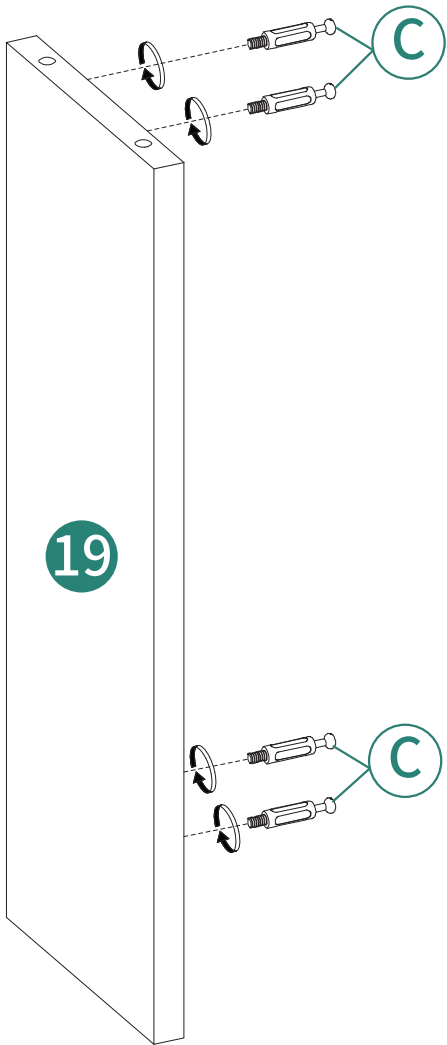
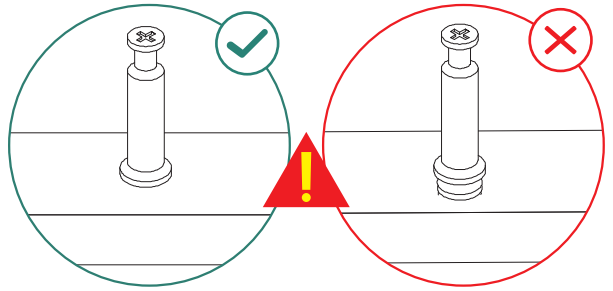
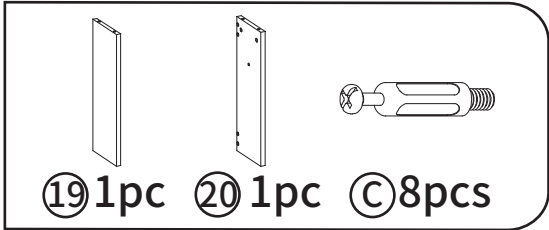

**1**

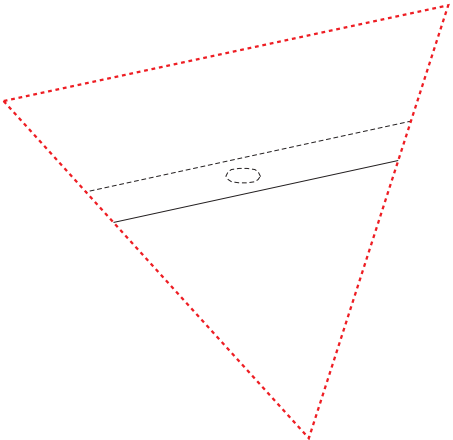
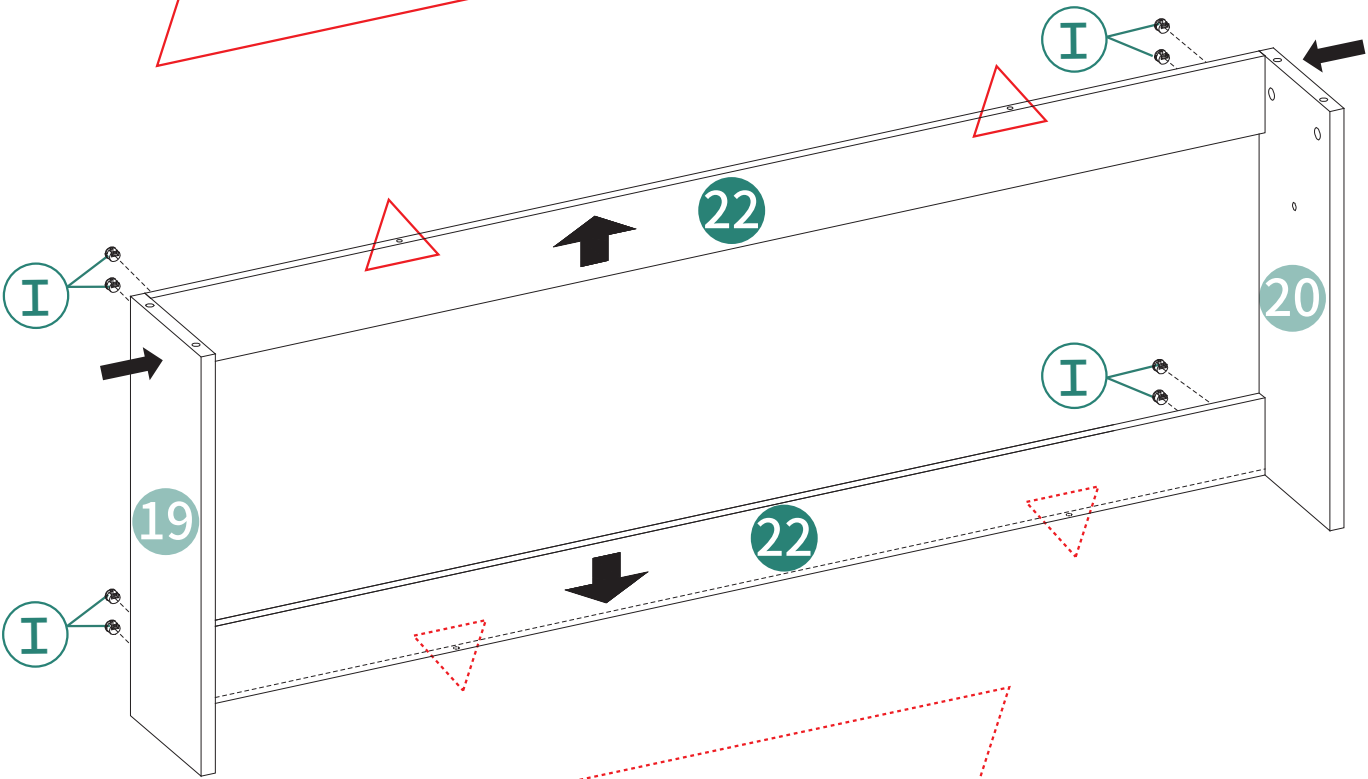
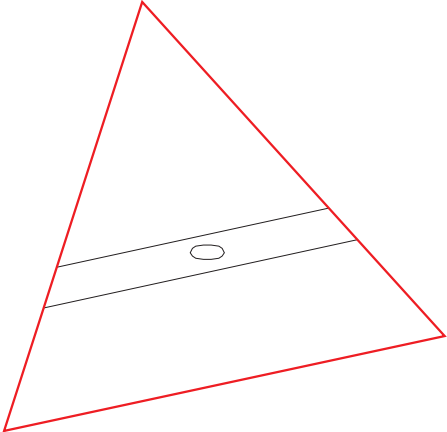
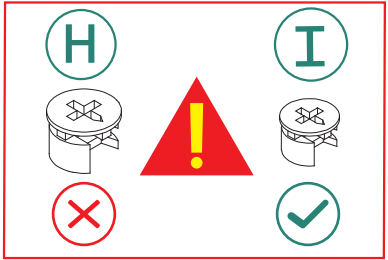

2

22 2pcs I 8pcs



# 3



②① 1pc ②③ 1pc ③ 4pcs ④ 2pcs

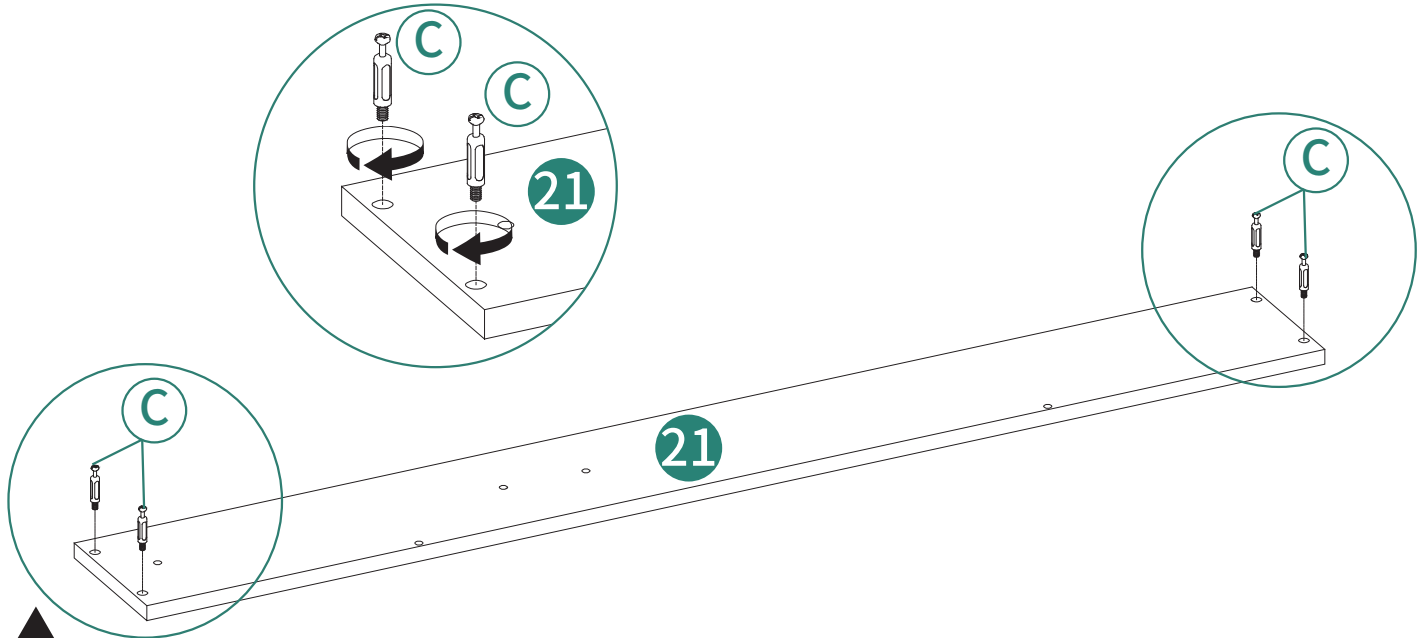
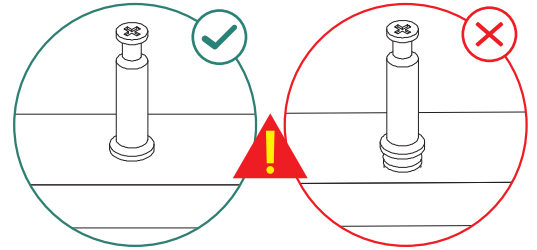

1

Pay attention to the installation direction of accessory 23.

Achten Sie auf die Installationsrichtung von Zubehör 23.

Faites attention à la direction d'installation de l'accessoire 23.

Fare attenzione alla direzione di installazione dell'accessorio 23.

Preste atención a la dirección de instalación del accesorio 23.

2

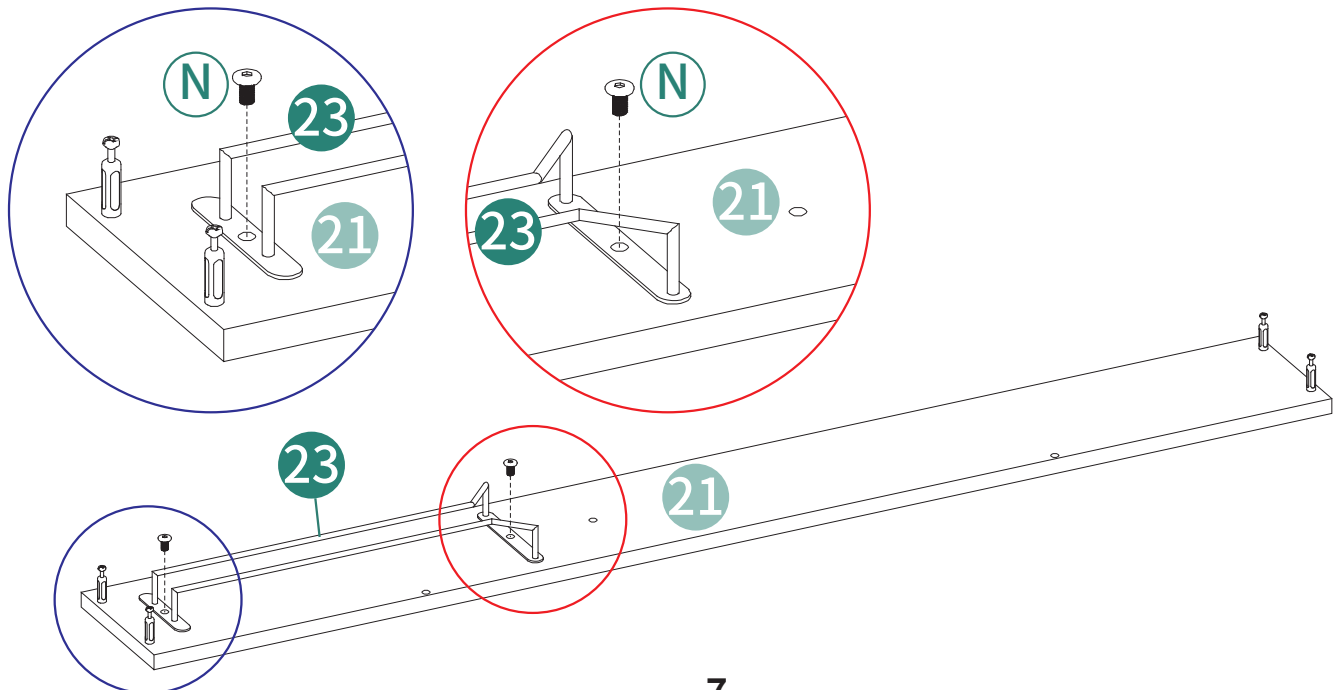



# 5

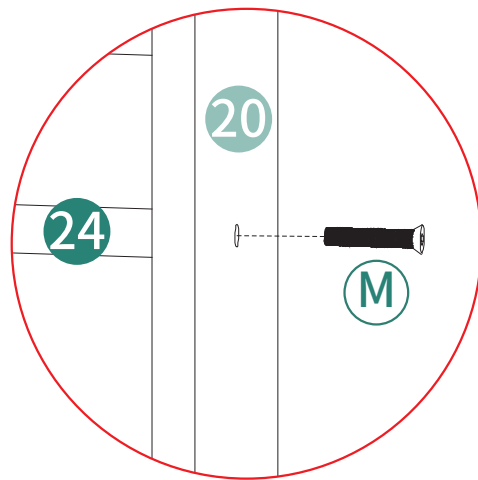
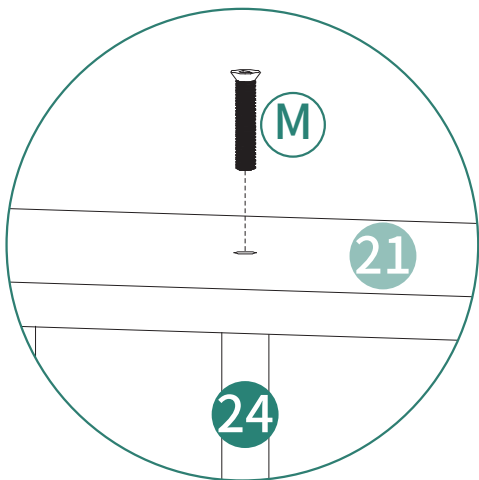
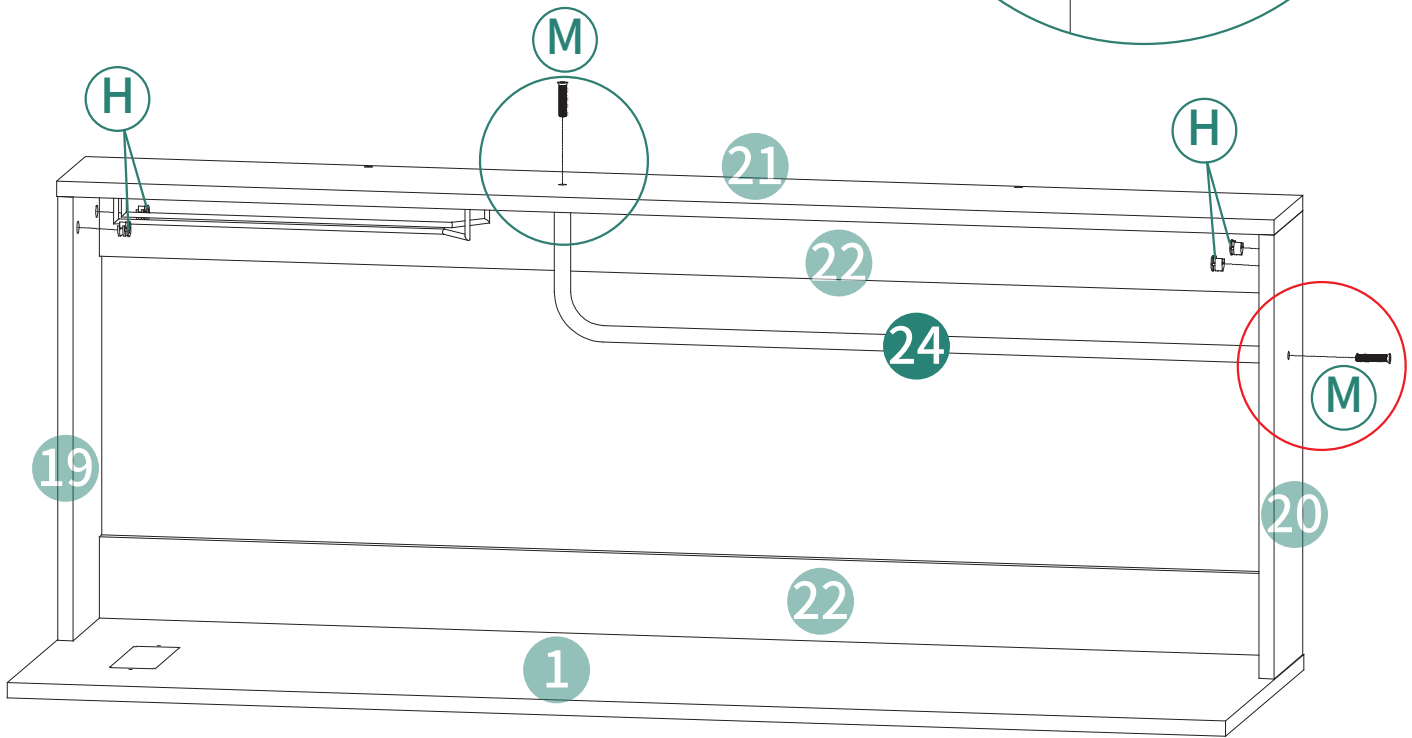
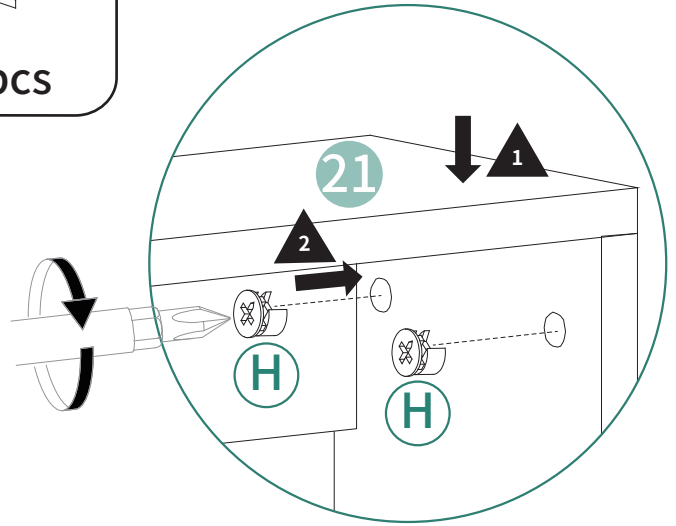
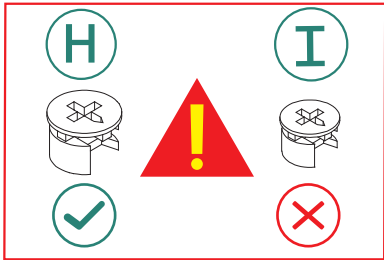
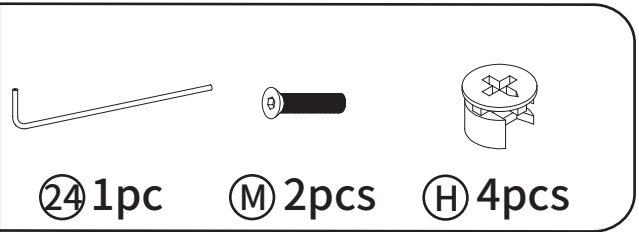

# 6

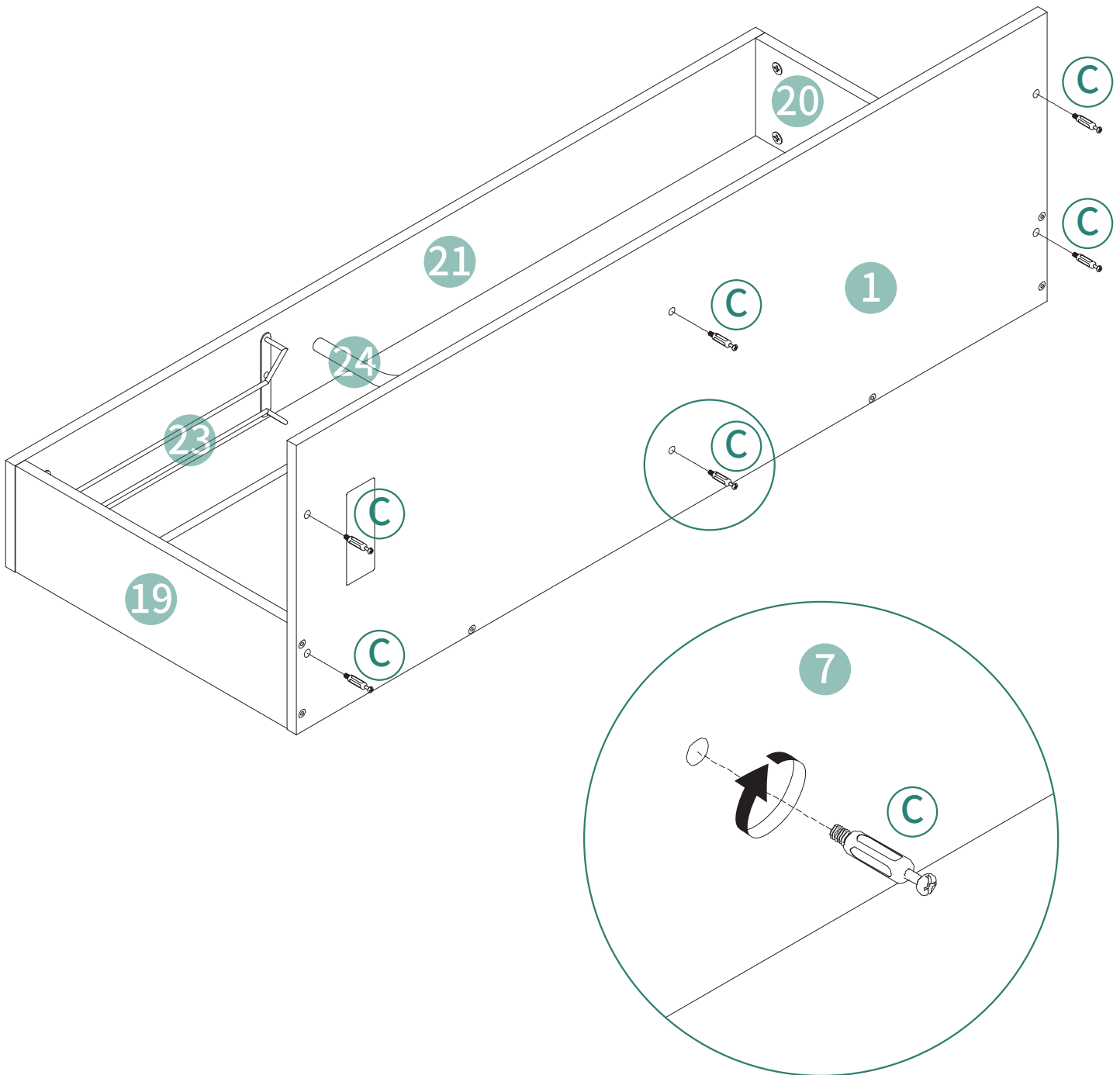
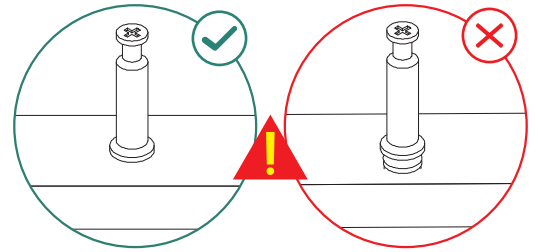
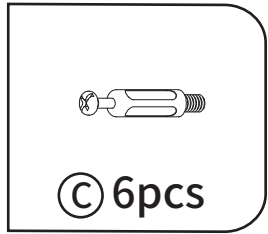



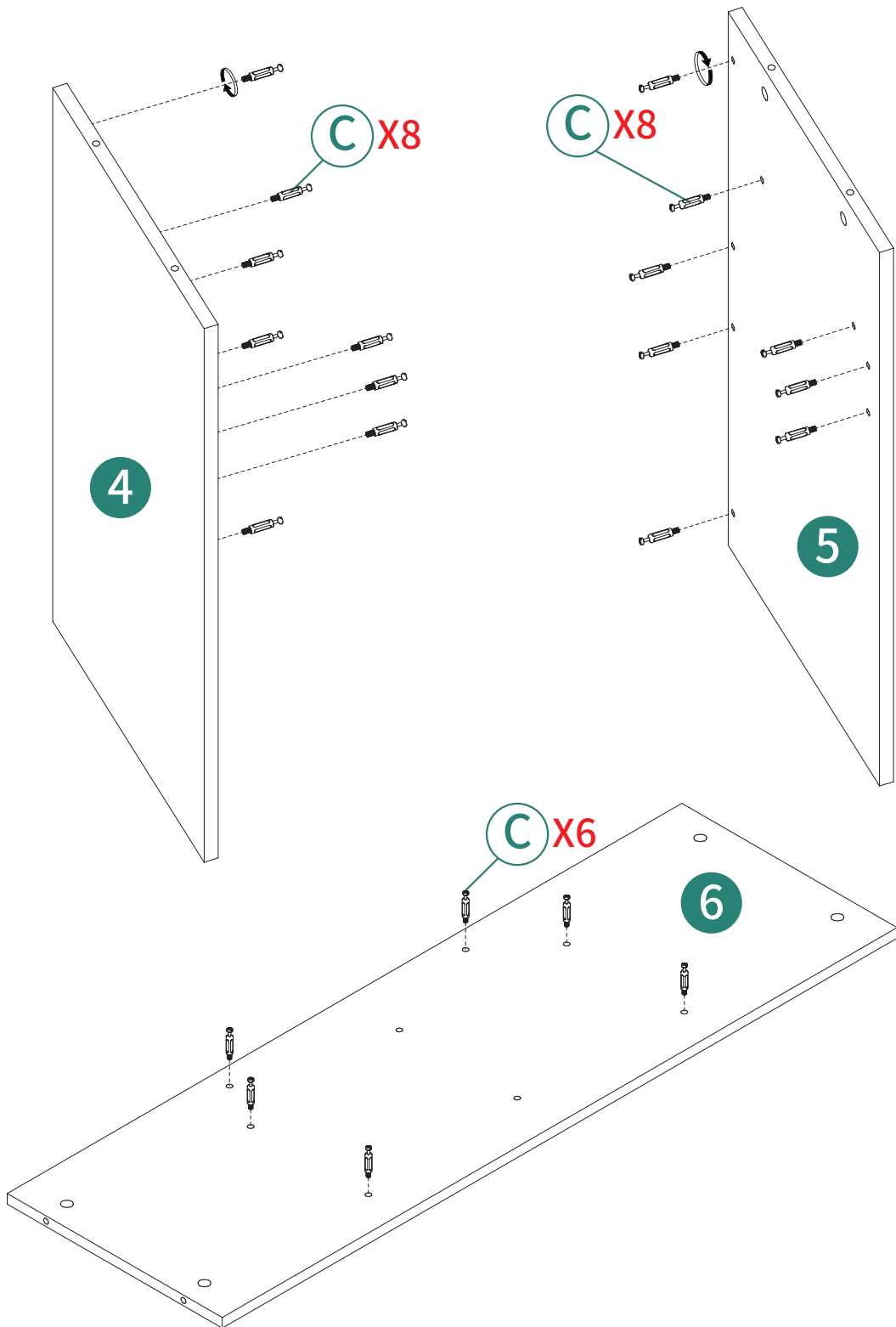
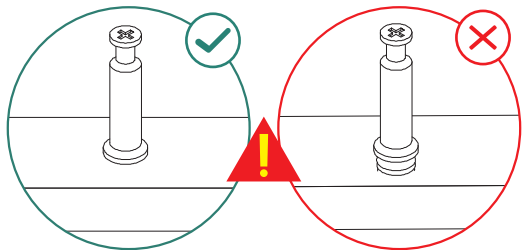

# 7

④ 1pc   ⑤ 1pc   ⑥ 1pc   ① 22pcs



8

-  ⑩ 1pc
-  ⑪ 1pc
-  ② 4pcs
-  ③ 4pcs

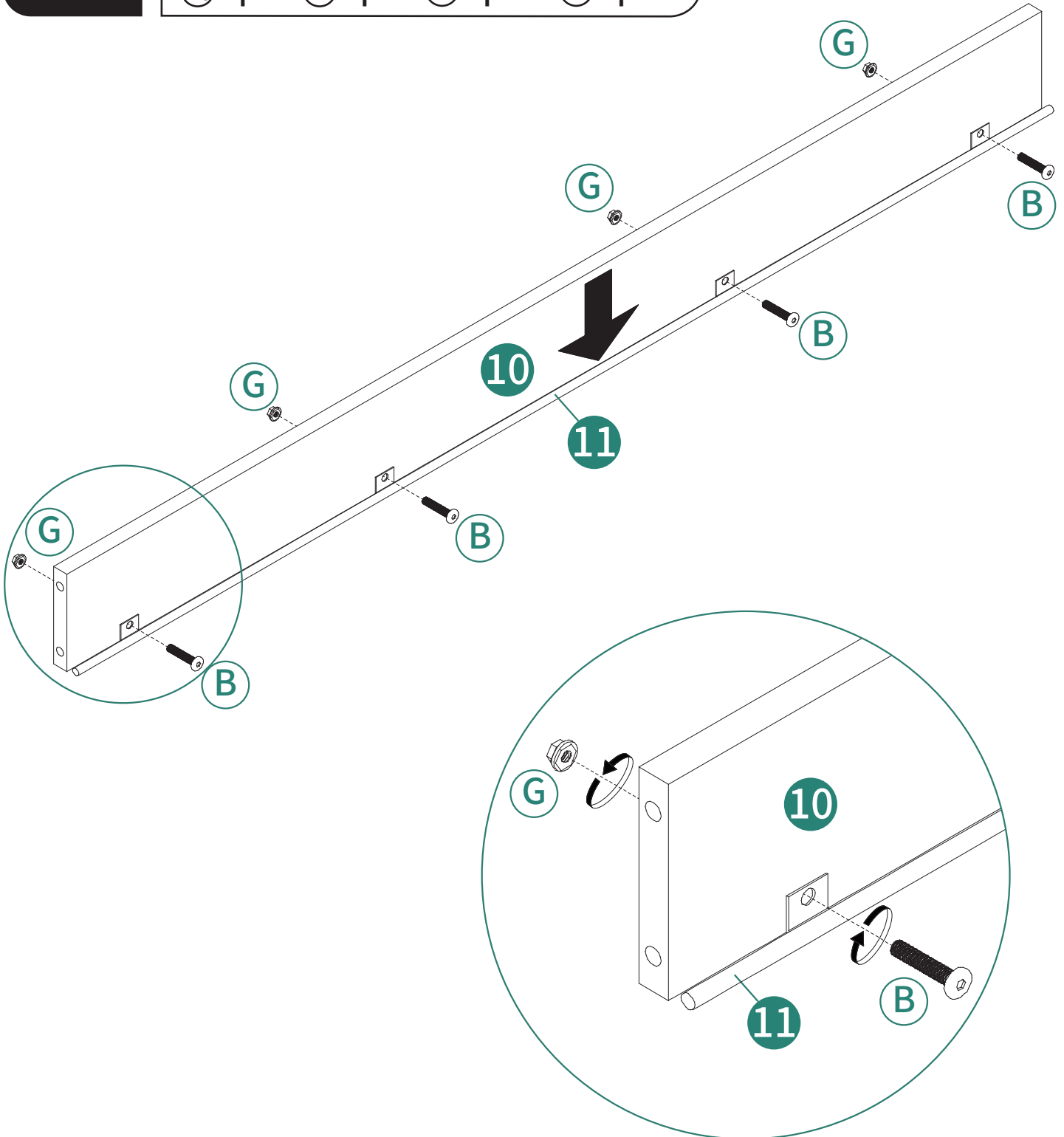

9

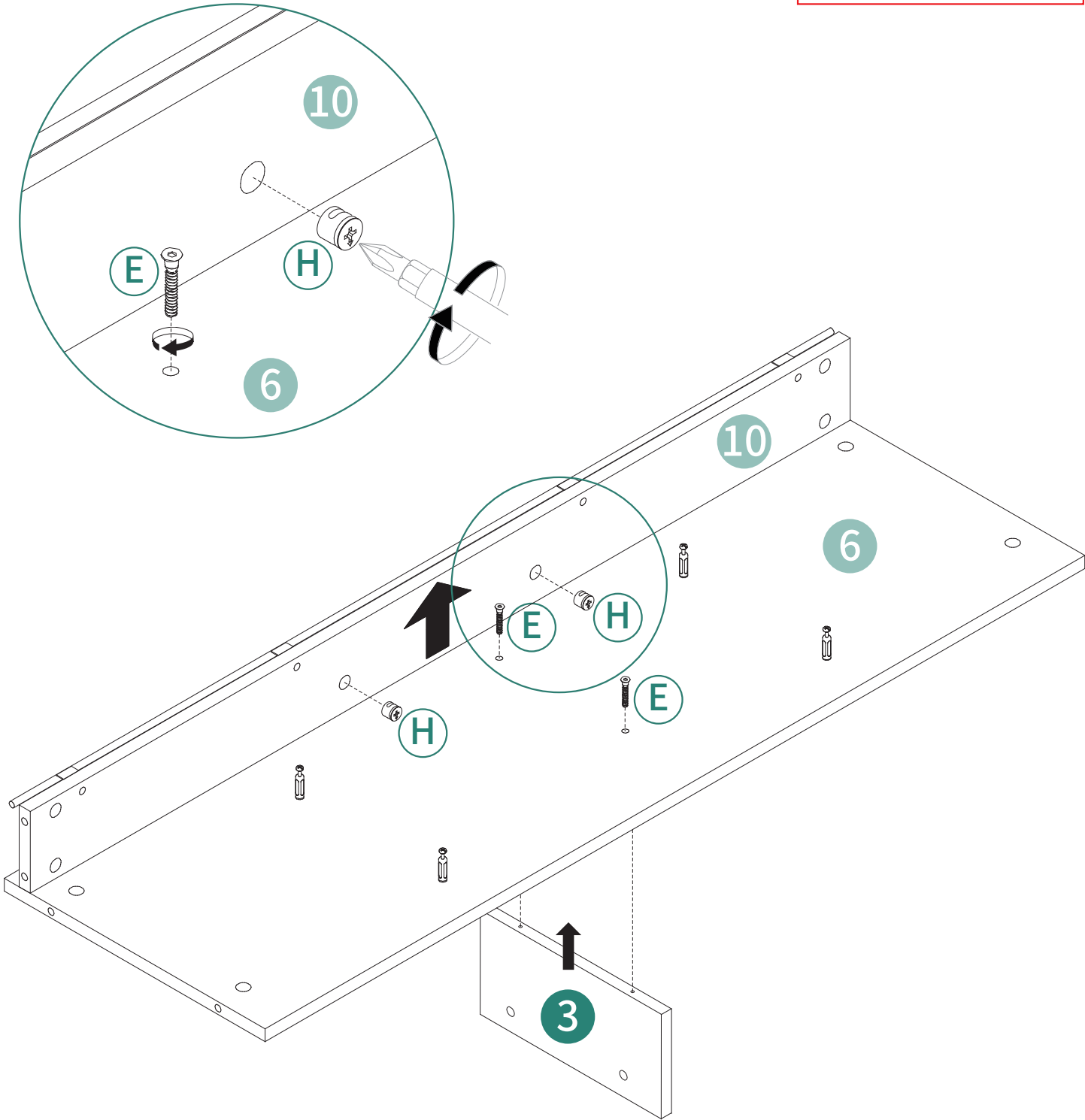
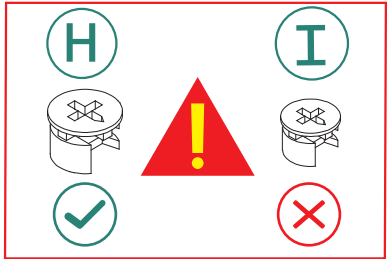
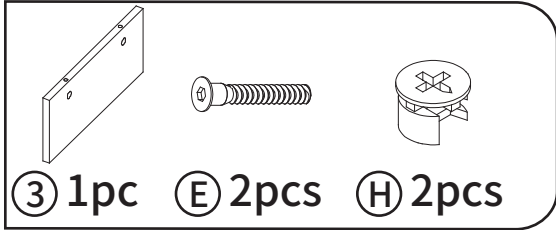

# 10

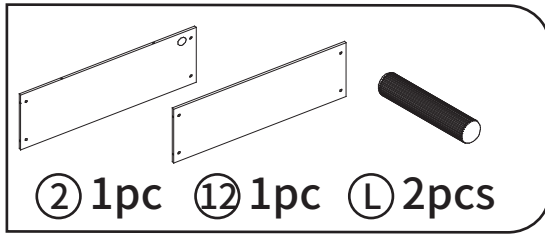

Note: Make sure the positions marked by triangles are facing the same direction.

Hinweis: Stellen Sie sicher, dass die Positionen, die durch Dreiecke markiert sind, in die gleiche Richtung zeigen.

Note : Assurez-vous que les positions marquées par des triangles sont orientées dans la même direction.

Nota: Assicurati che le posizioni contrassegnate da triangoli siano rivolte nella stessa direzione.

Nota: Asegúrate de que las posiciones marcadas con triángulos estén orientadas en la misma dirección.

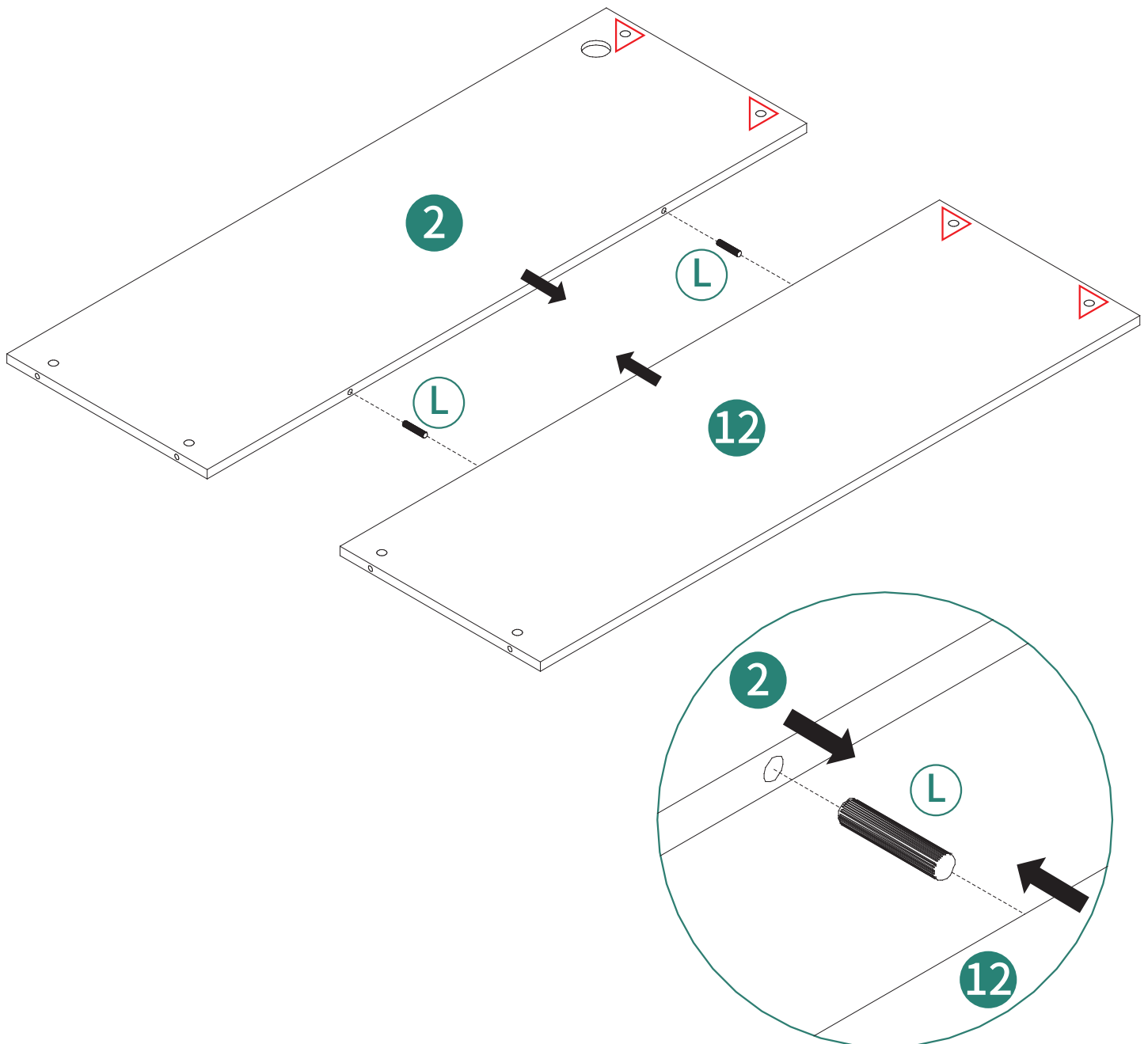

# 11

(H) 8pcs

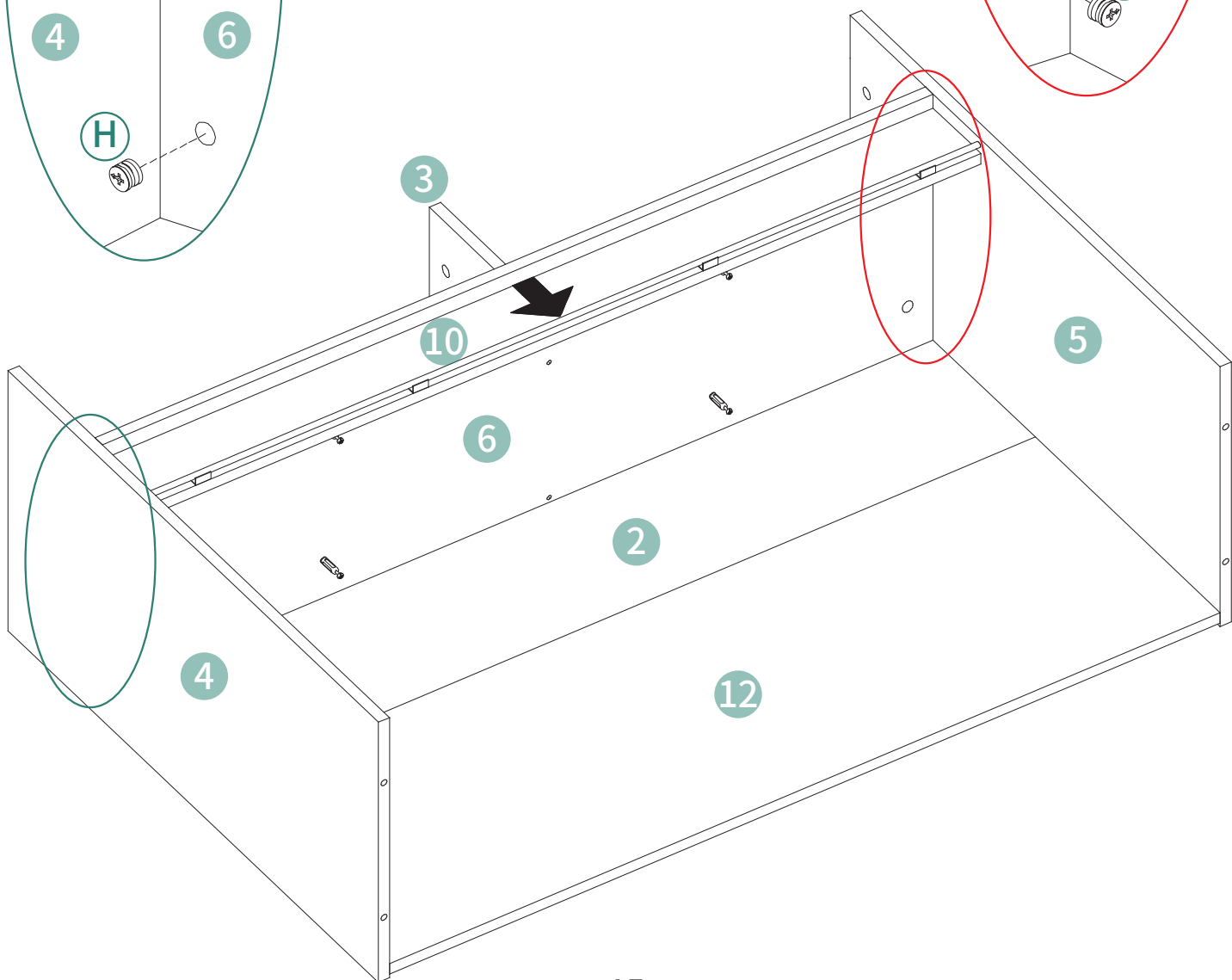
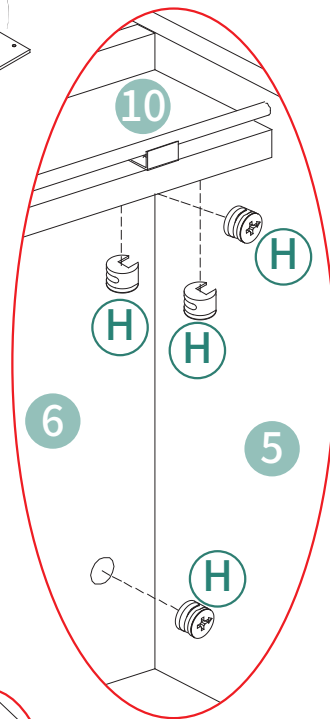
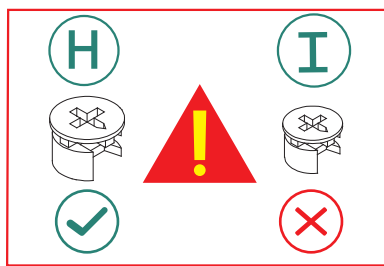
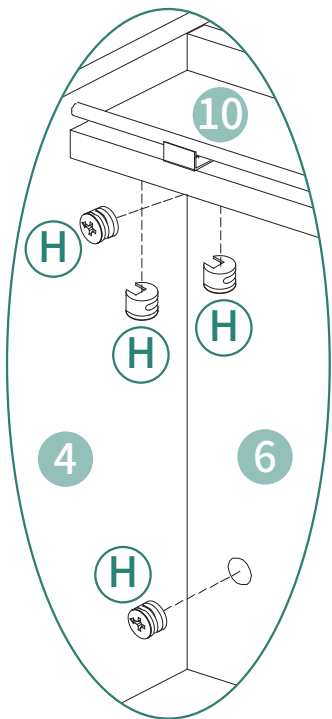
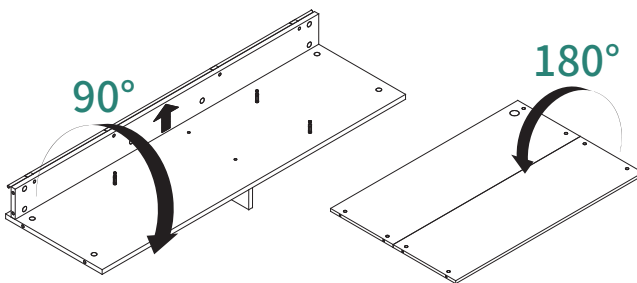

# 12

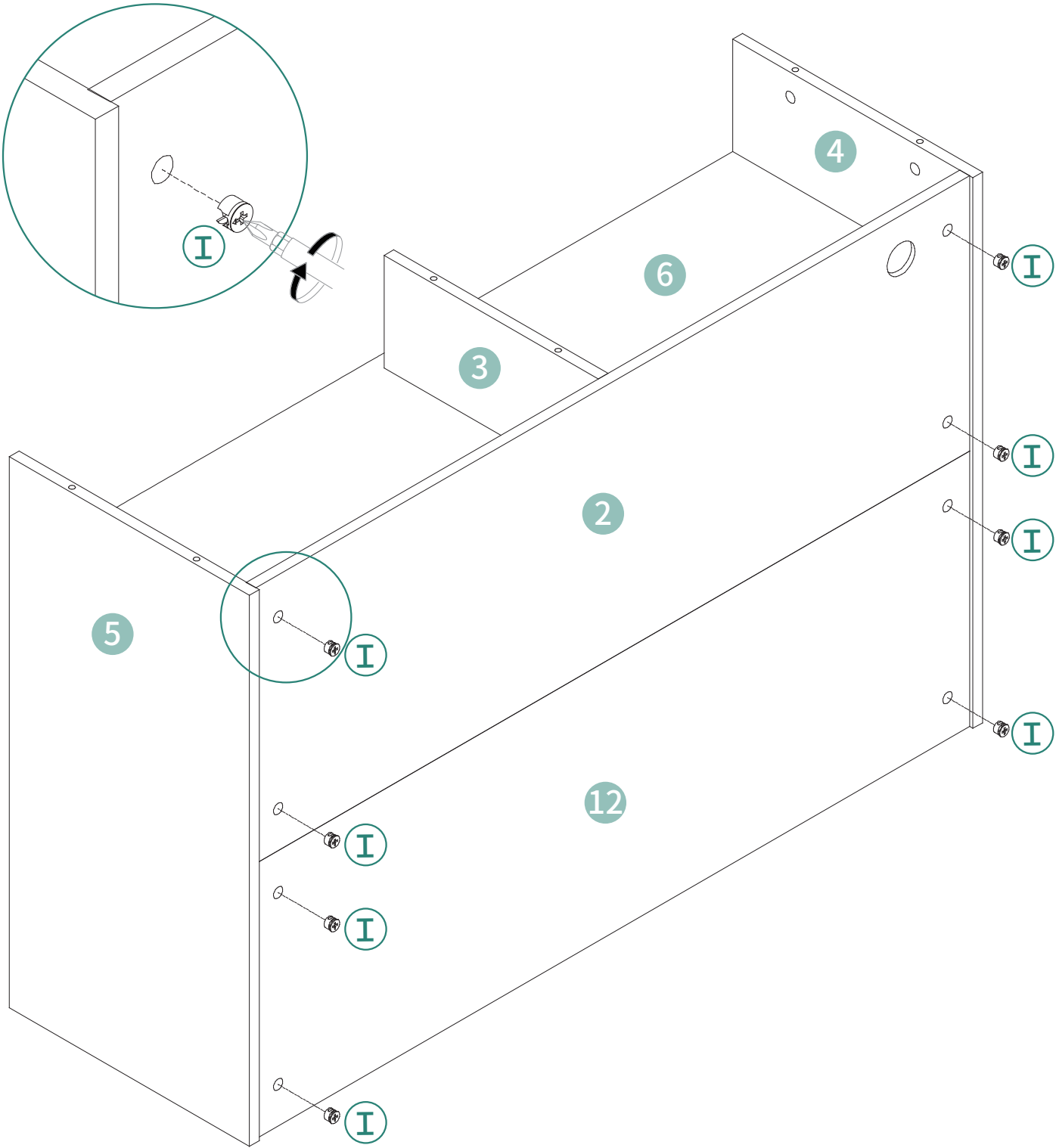
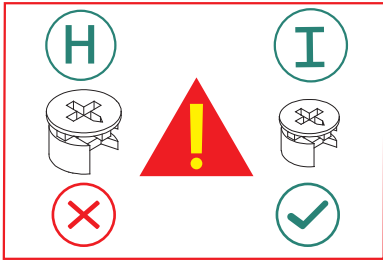
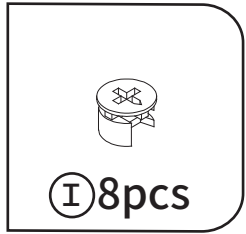

# 13



⑨ 2pcs

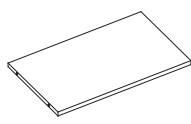

⑬ 1pc

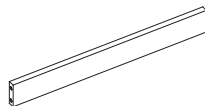

⑰ 2pcs



ⓔ 12pcs

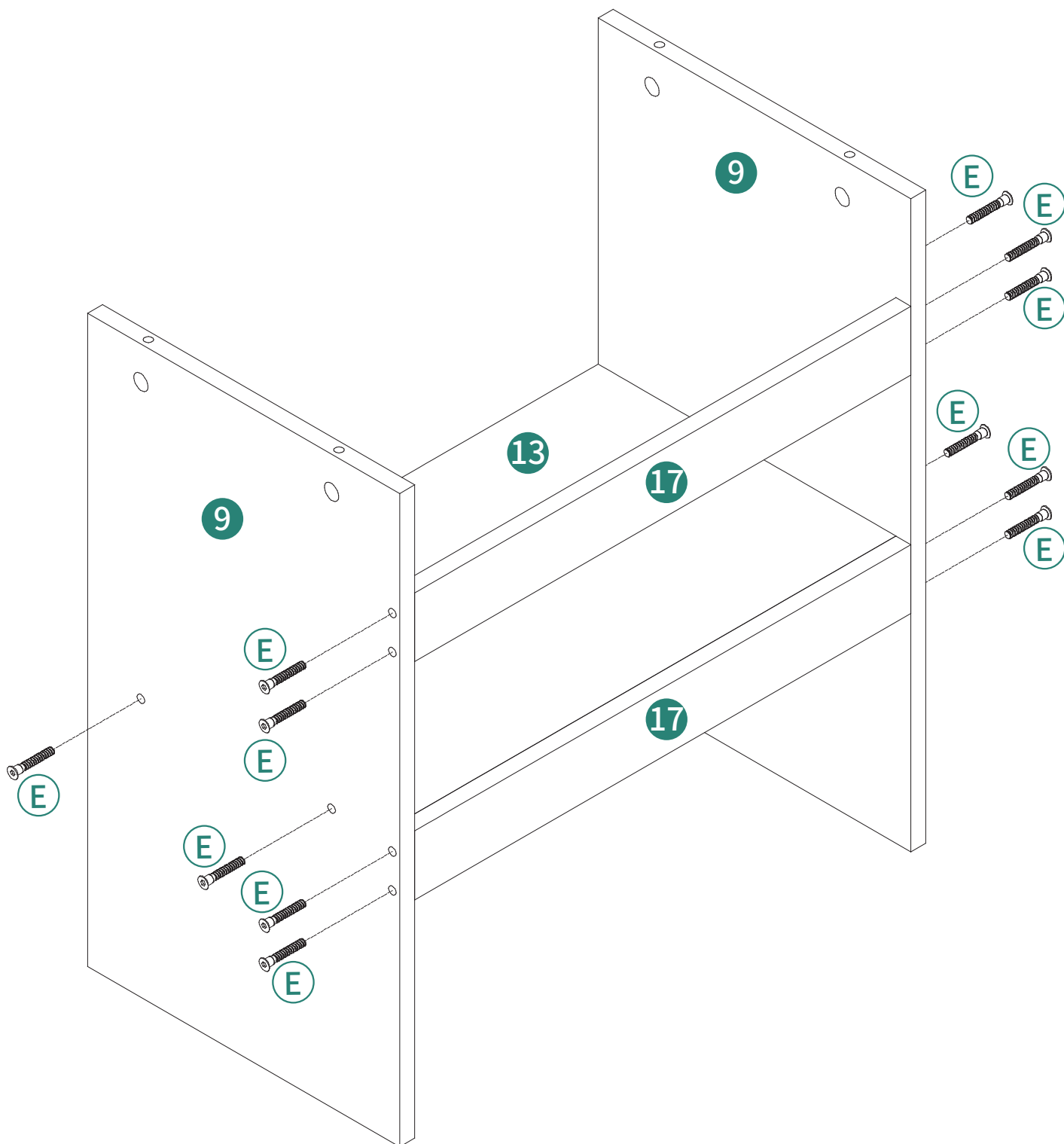

# 14

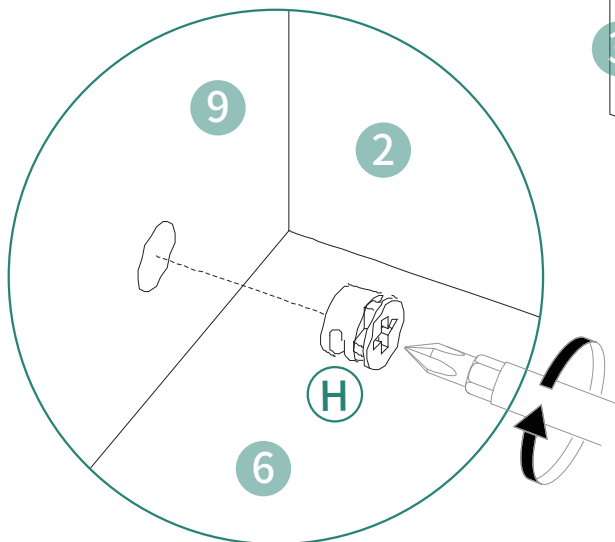
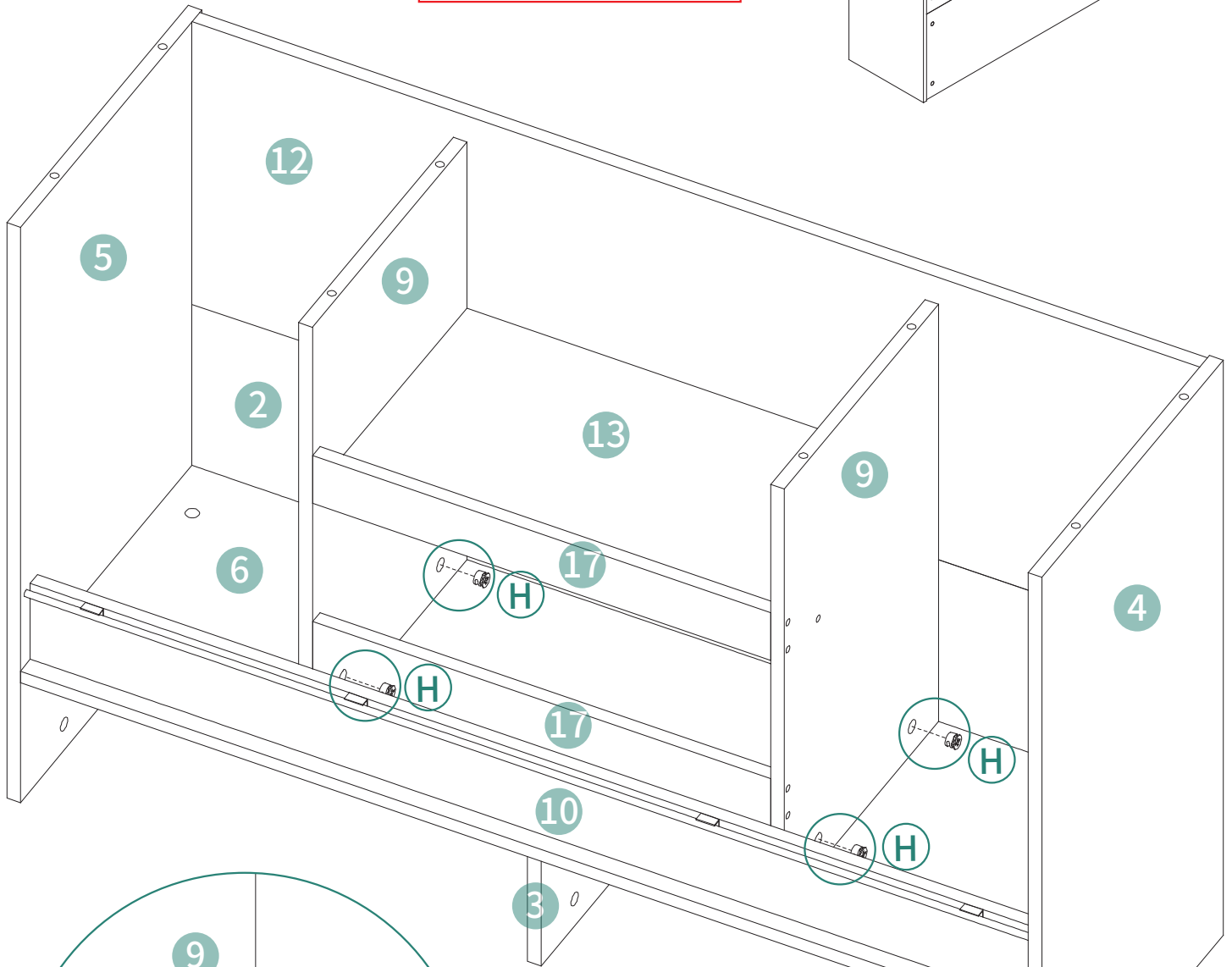
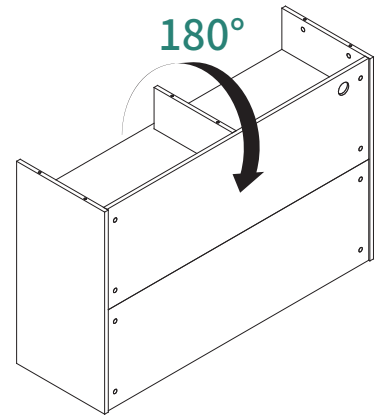
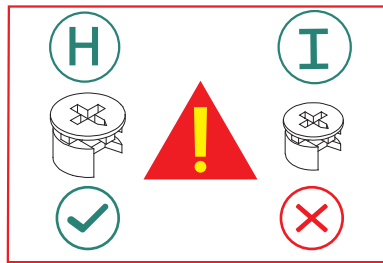
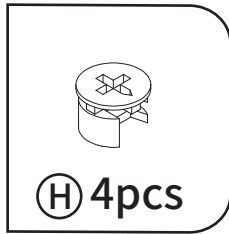

15

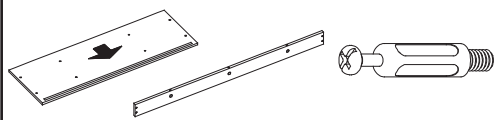

⑭ 1pc ⑯ 2pcs ⑰ 14pcs

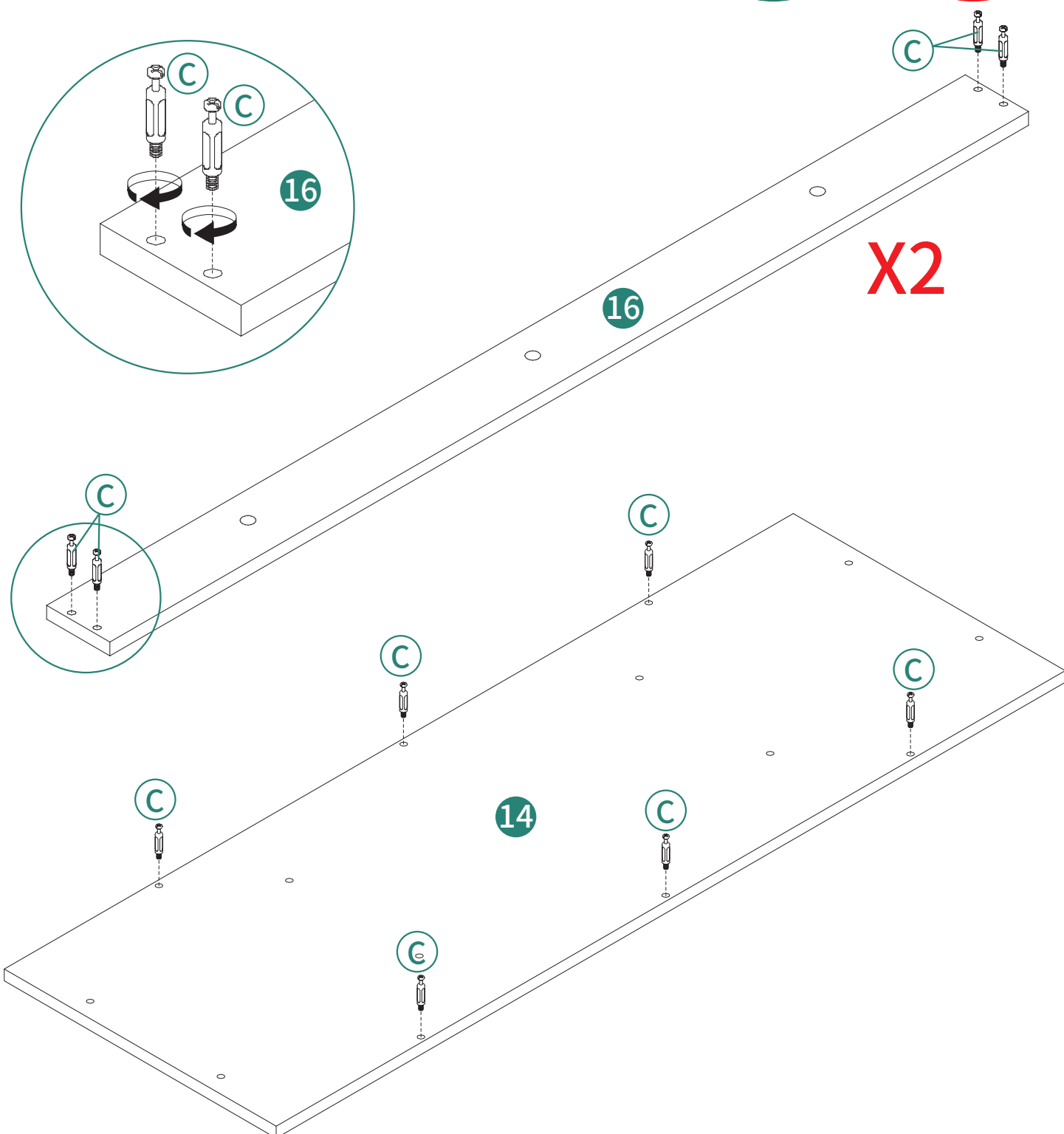
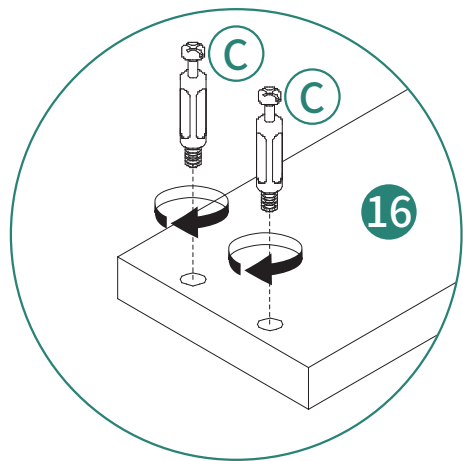
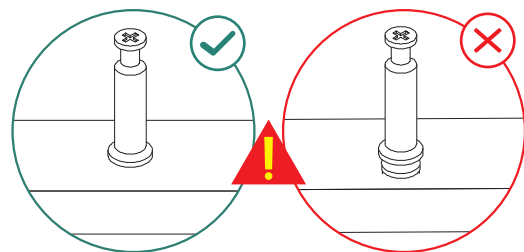

# 16

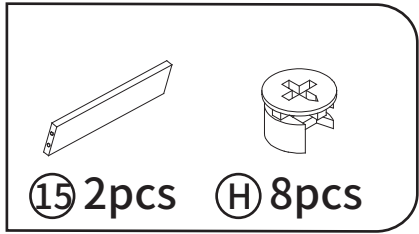

⑮ 2pcs    Ⓜ 8pcs

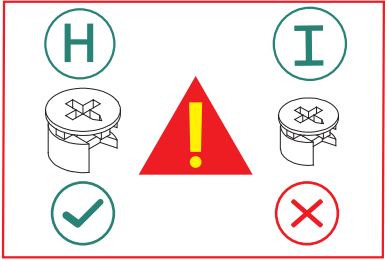

Ⓜ    Ⓜ  
Ⓜ    ⚠    Ⓜ  
✓    ✗

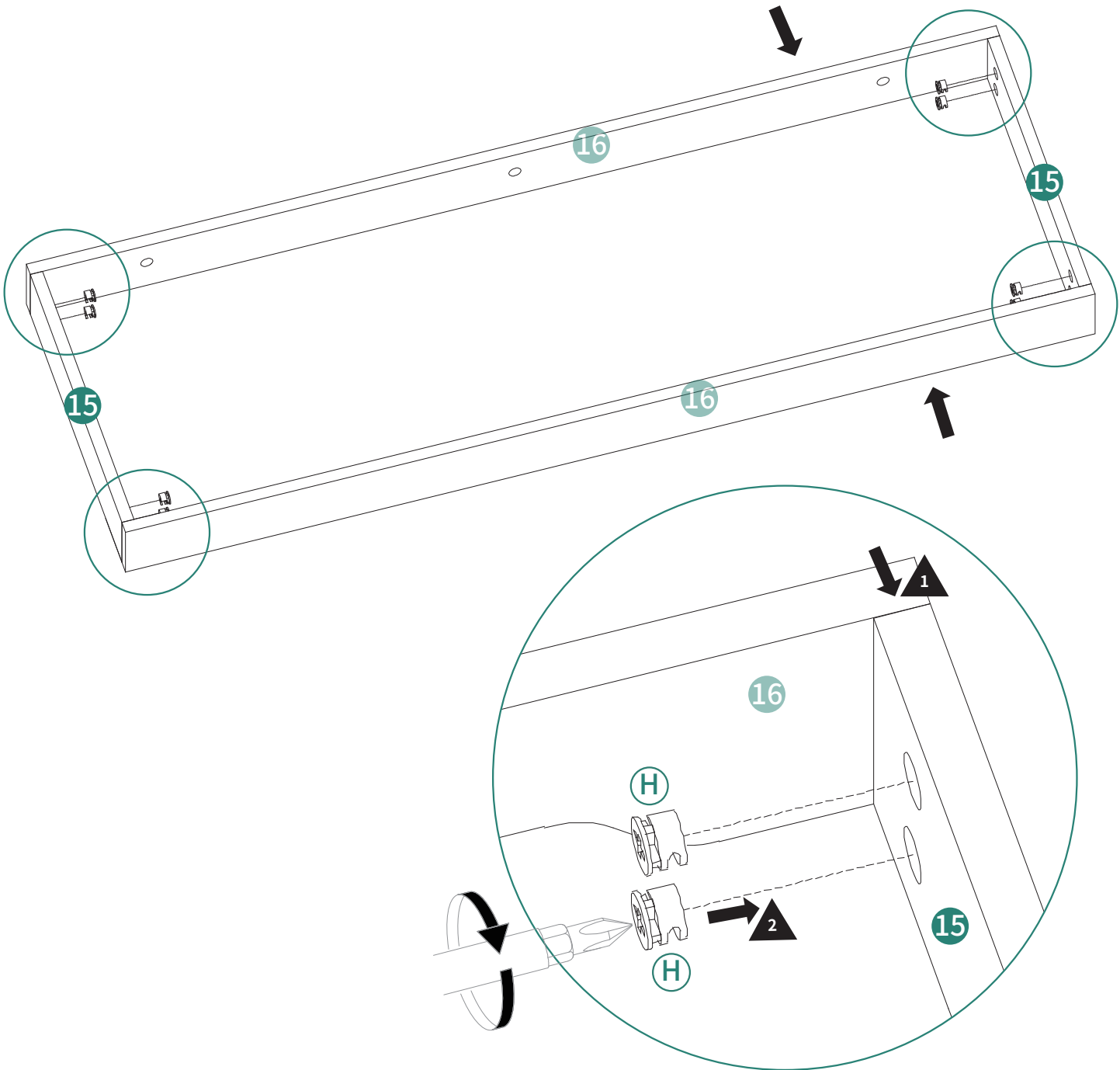

# 17

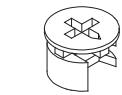

(H) 6pcs

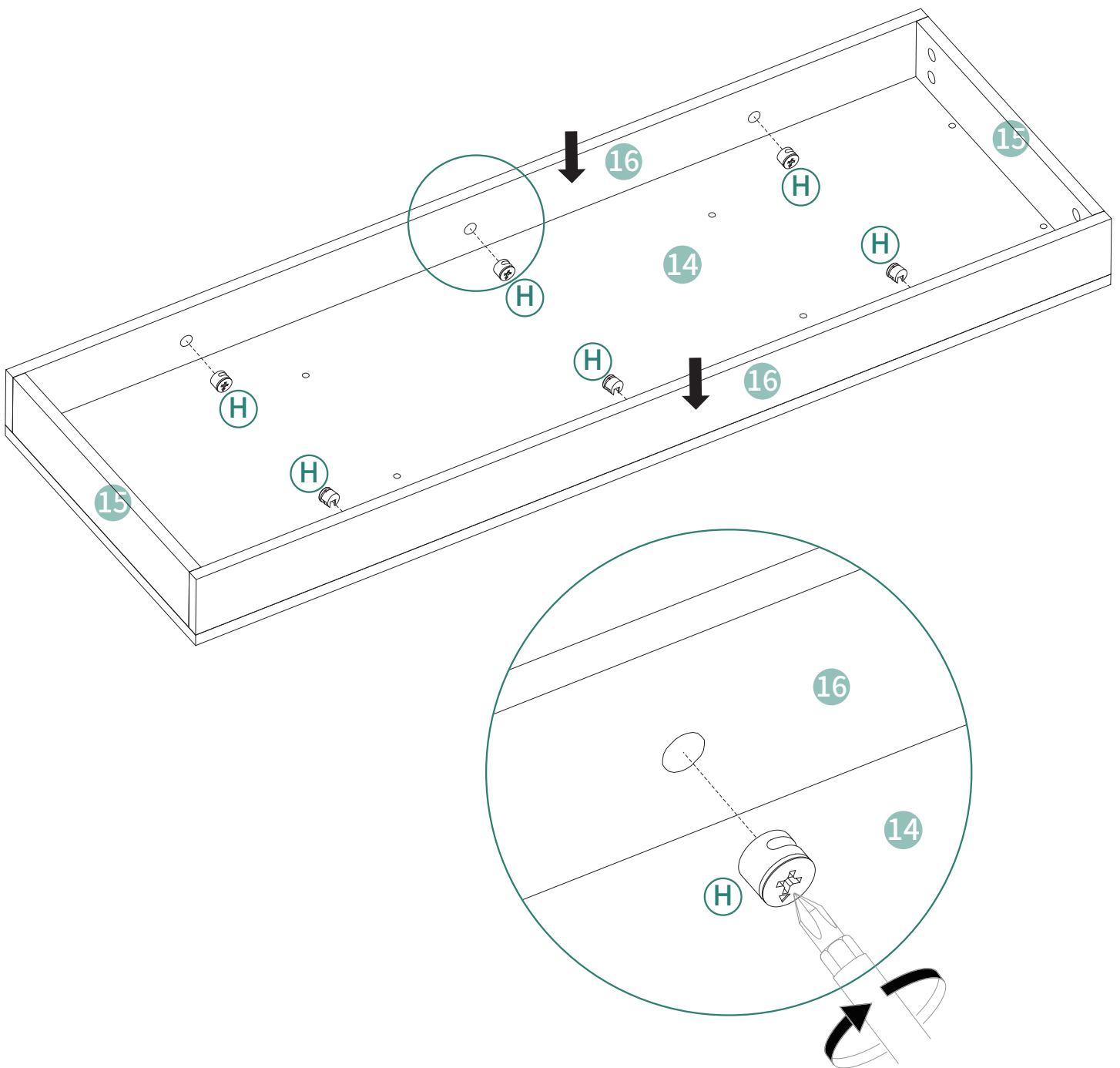
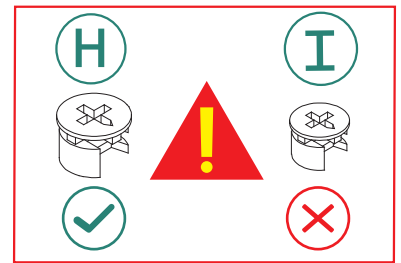

# 18



(E) 8pcs

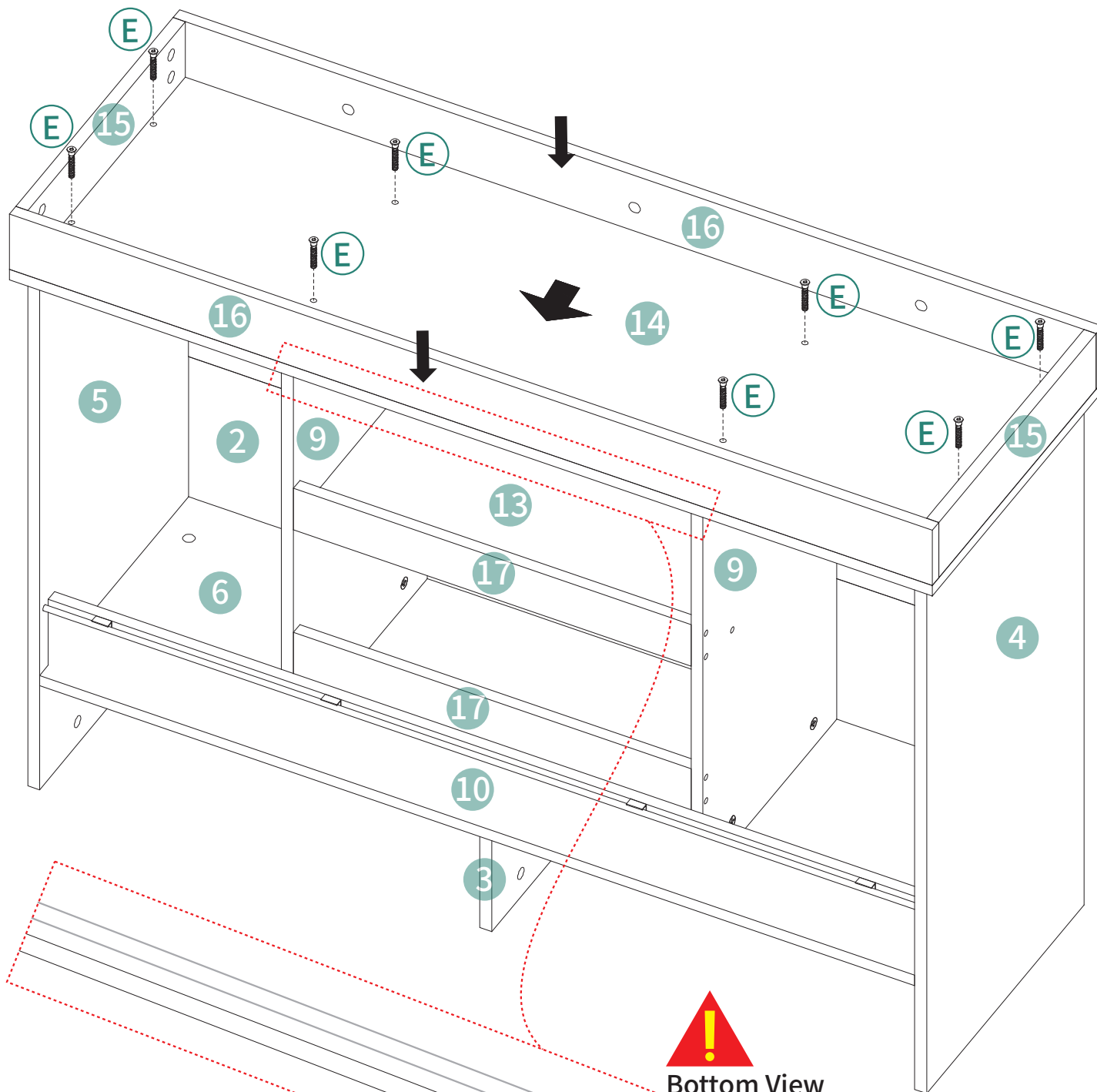

Bottom View  
Unteransicht  
Vue du bas  
Vista dal basso  
Vista inferior

# 19

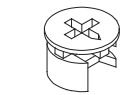

(H) 6pcs

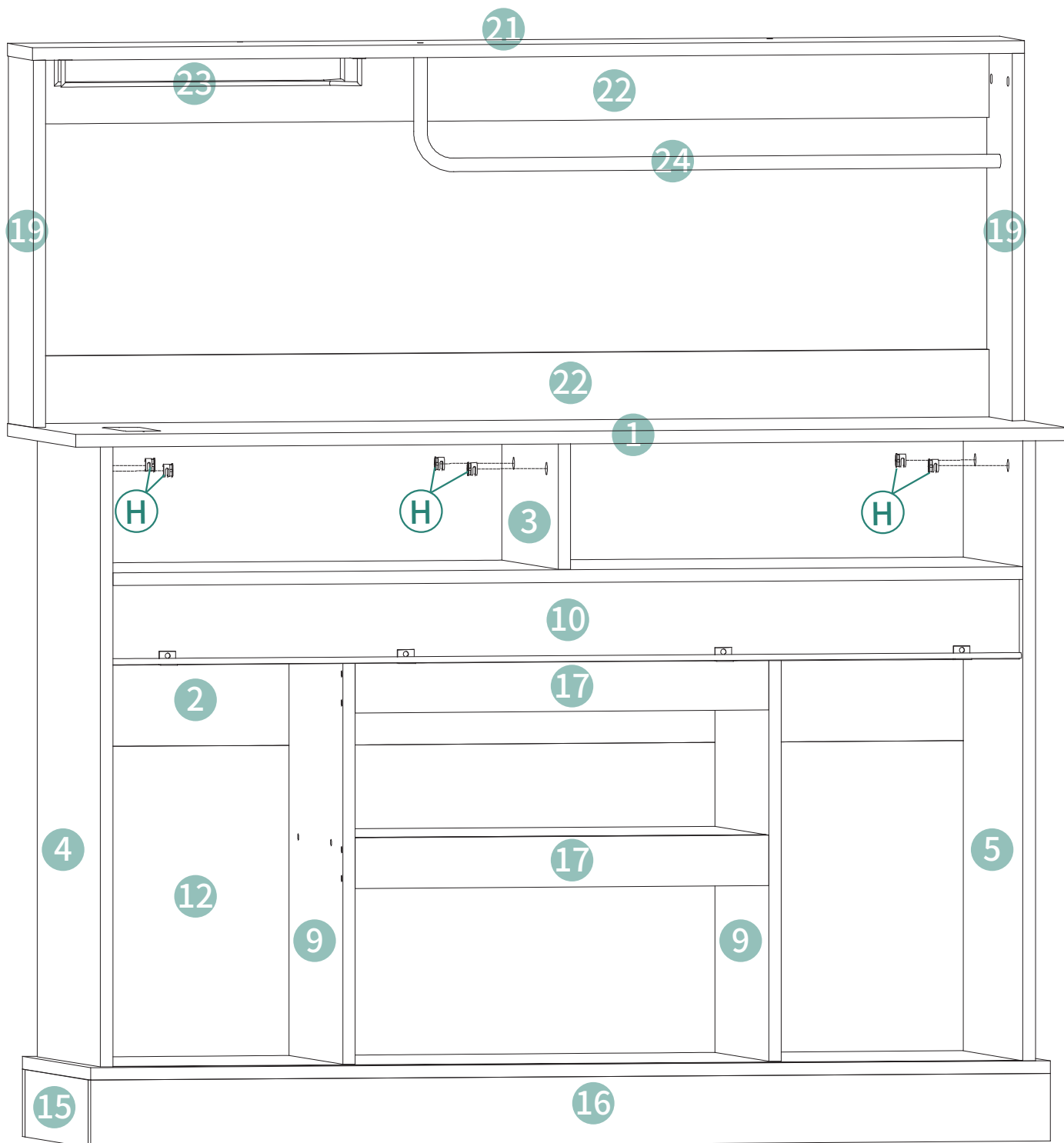
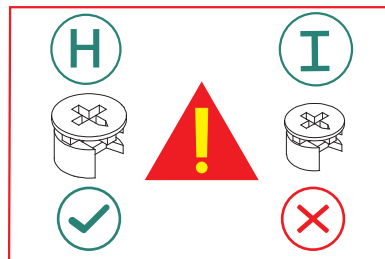

20

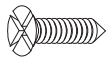
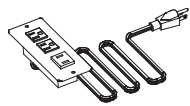

18 1pc

F 2pcs

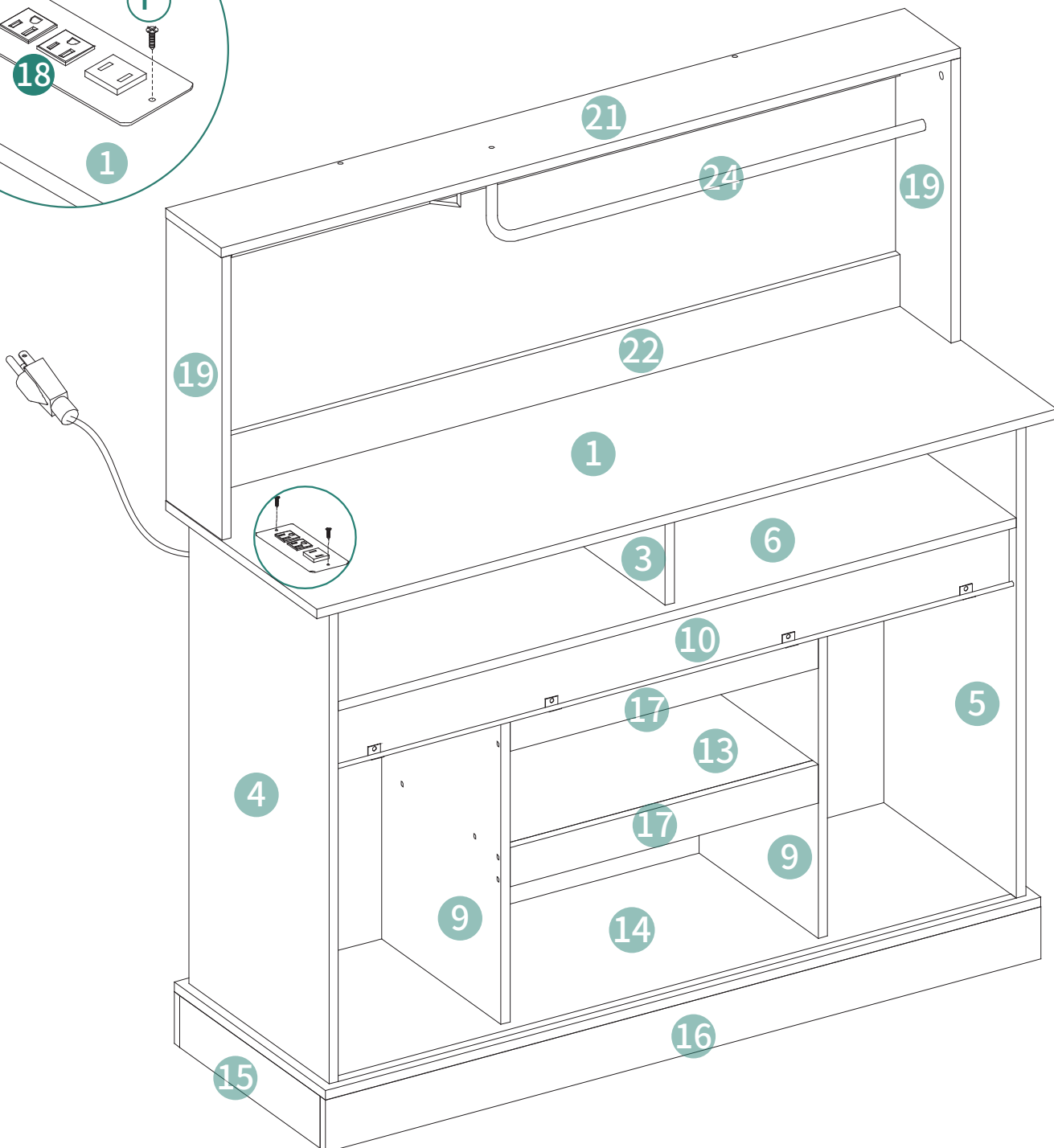
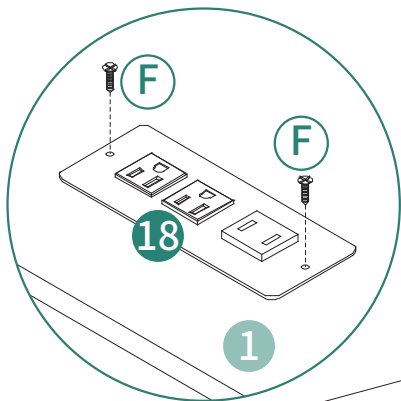

# 21

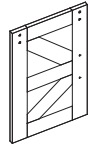

⑦ 1pc

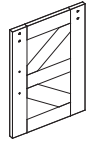

⑧ 1pc



① B 8pcs



② G 8pcs

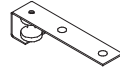

③ J 4pcs

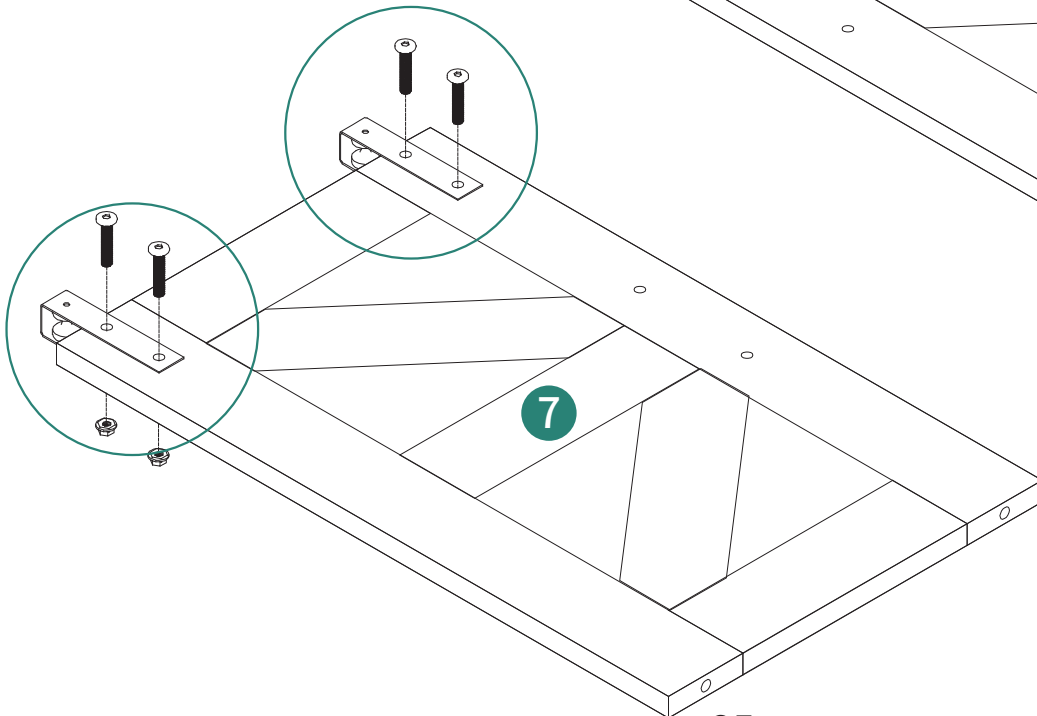
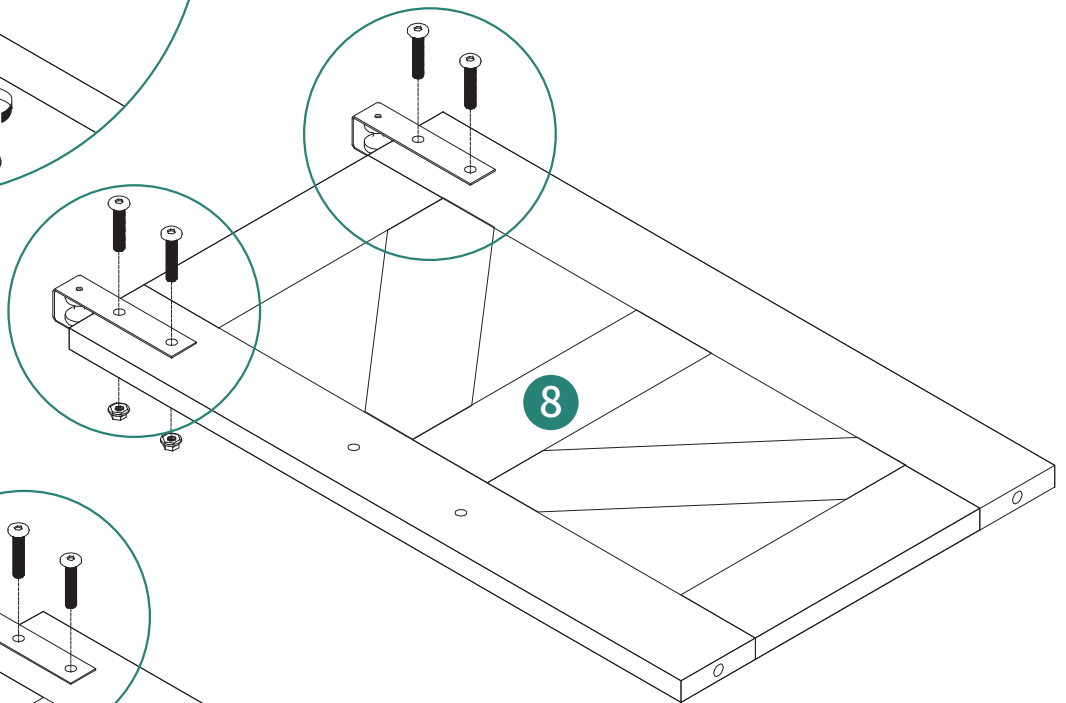
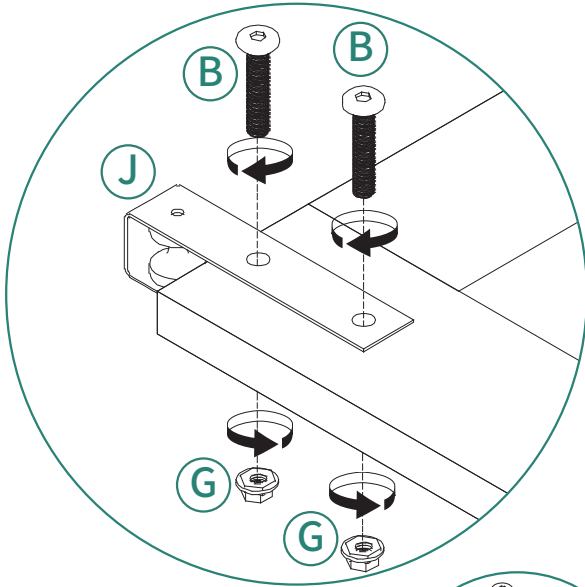

# 22

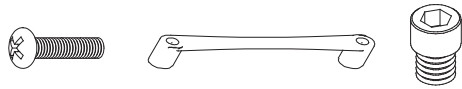

Ⓐ 4pcs Ⓓ 2pcs Ⓚ 4pcs

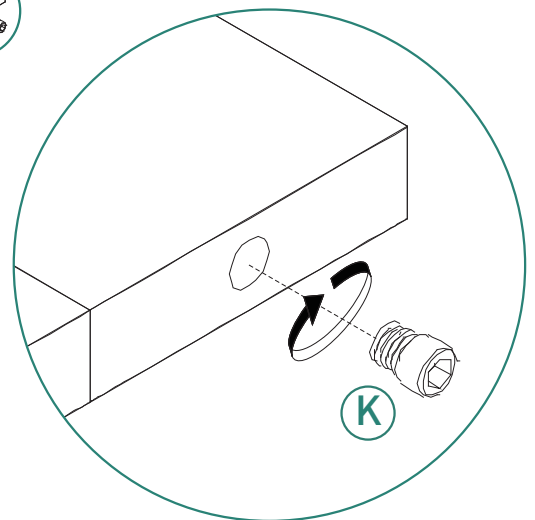
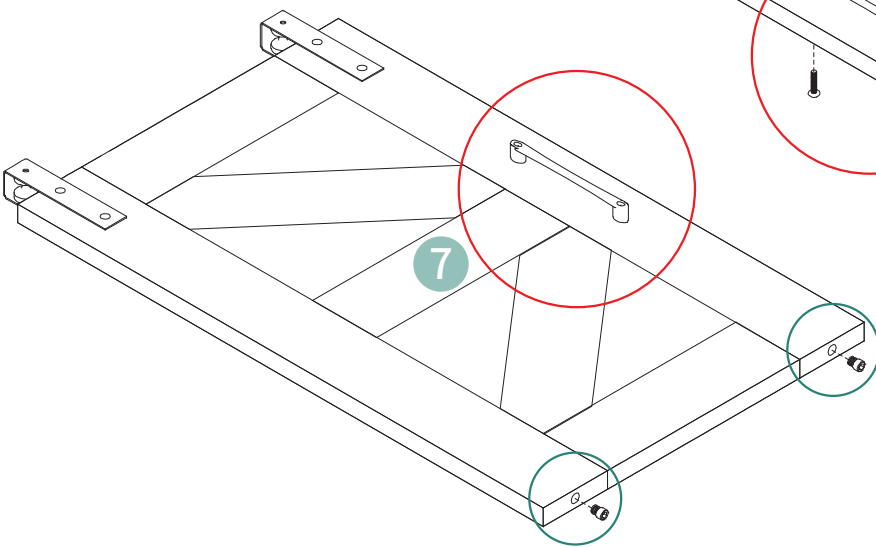
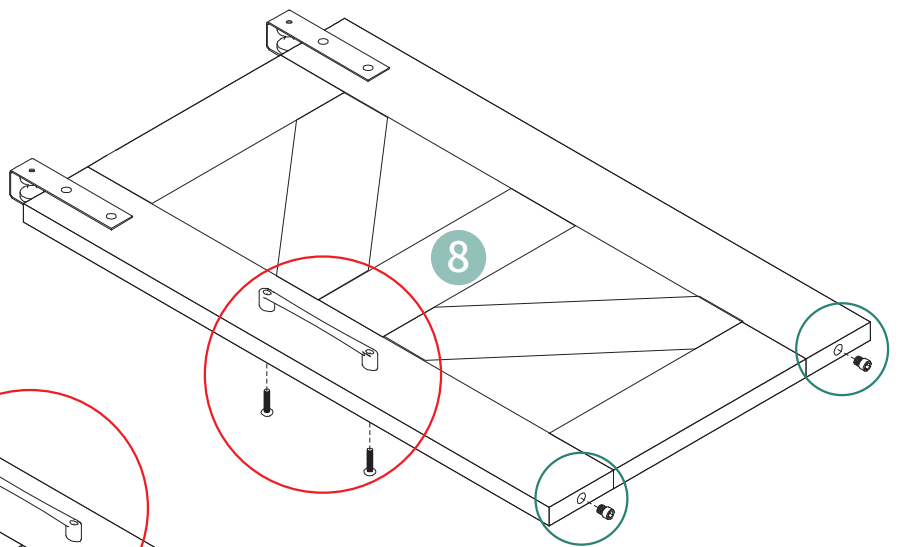
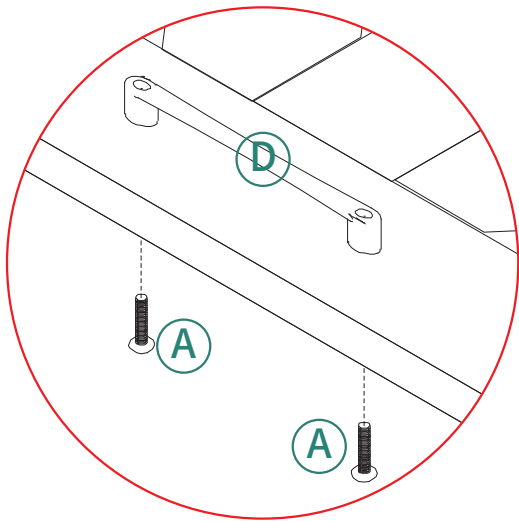

# 23

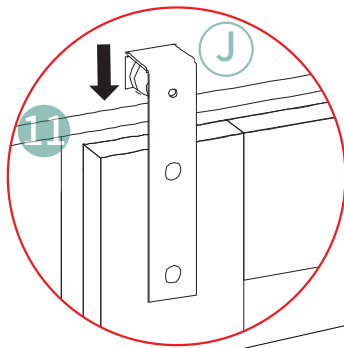
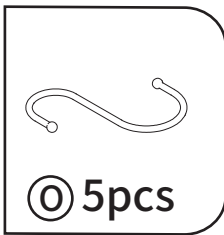

Not included  
Nicht enthalten  
Non inclus  
Non incluso  
No incluido

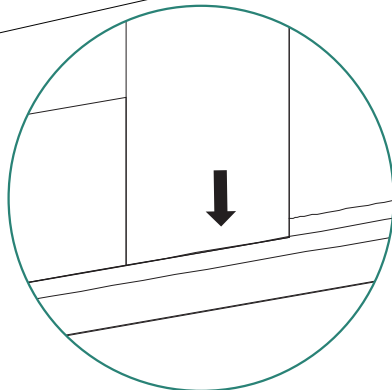
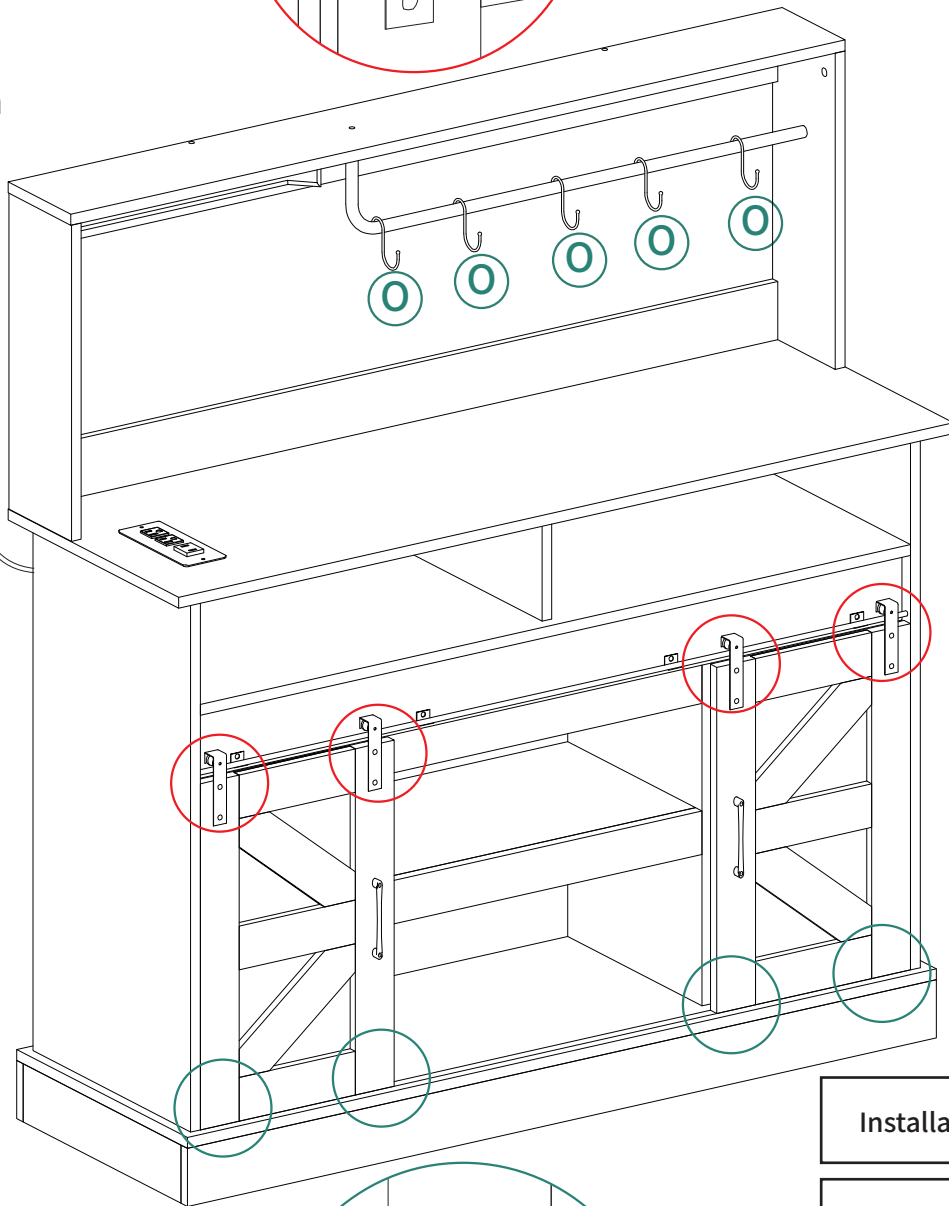

Installation Completed

Installation abgeschlossen

Installation complétée

Installazione completata

Instalación completada