

ORIGINAL INSTRUCTION MANUAL

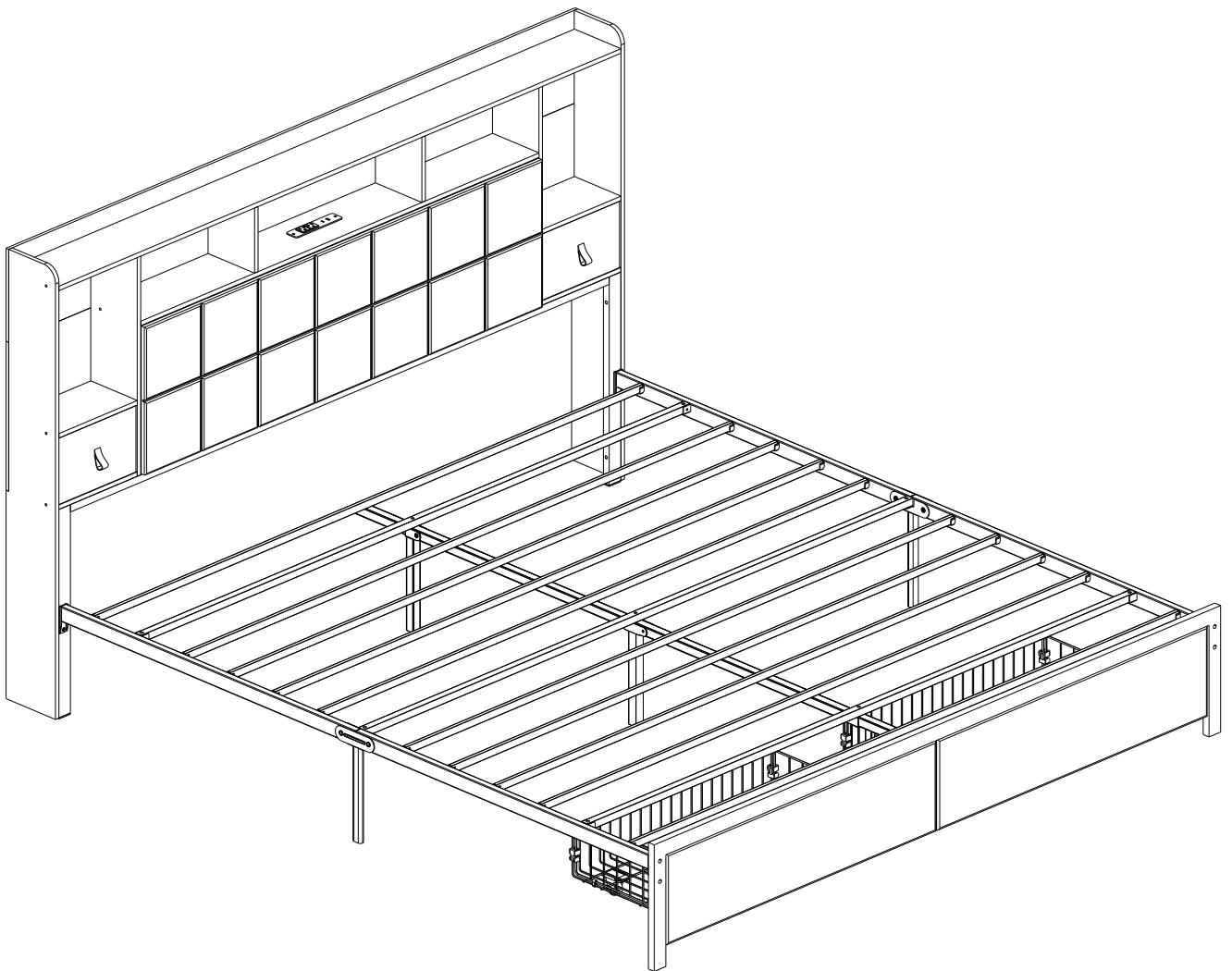

Important Note

HARDWARE NOTE :

1. Two or more people are required for assembly
2. Do not screw on the bolts too tight unless the installation is done. Make sure all bolts are tightly screwed before you use it.

Assembly Instruction

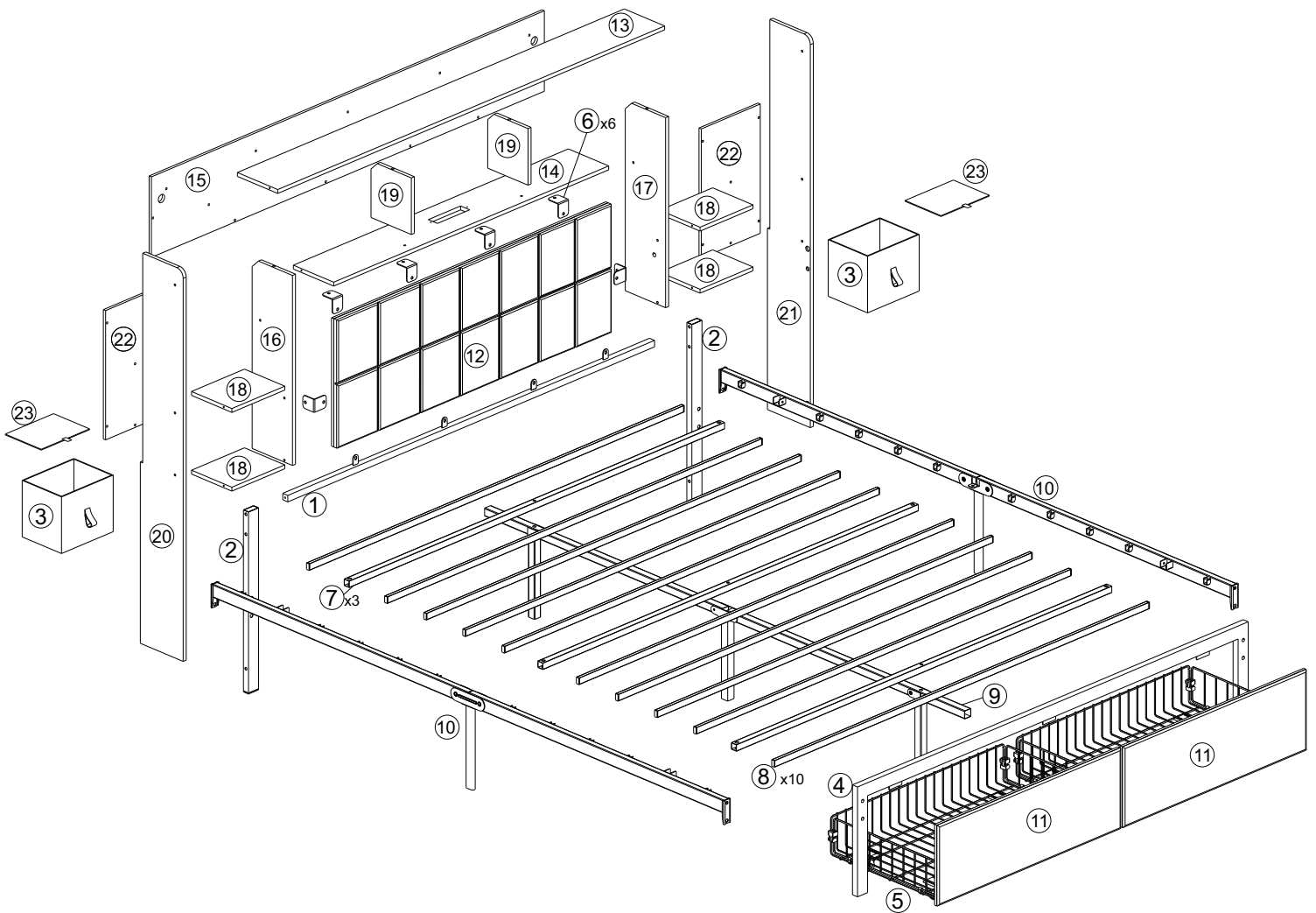

Important Note

HARDWARE NOTE :

1. Two or more people are required for assembly
2. Do not screw on the bolts too tight unless the installation is done. Make sure all bolts are tightly screwed before you use it.

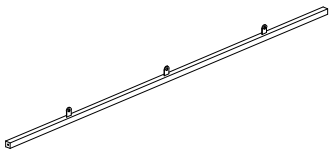

① × 1pc

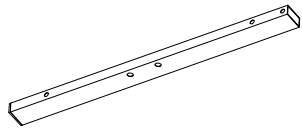

② × 2pcs

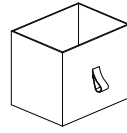

③ × 2pcs

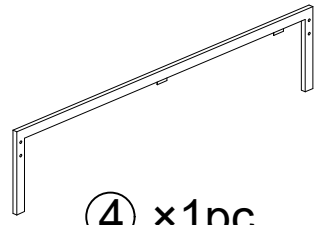

④ × 1pc

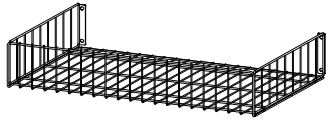

⑤ × 2pcs

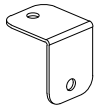

⑥ × 6pcs

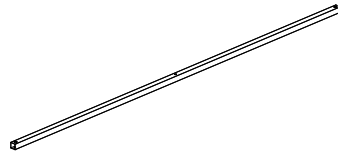

⑦ × 3pcs

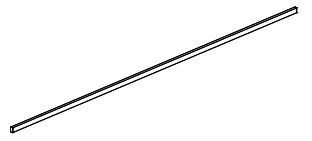

⑧ × 10pcs

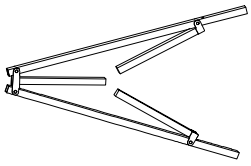

⑨ × 1pc

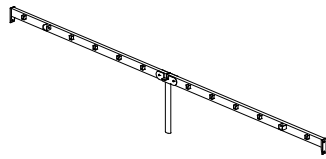

⑩ × 2pcs

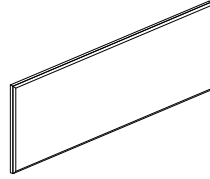

⑪ × 2pcs

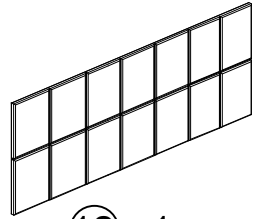

⑫ × 1pc

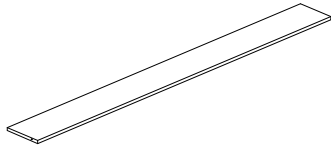

⑬ × 1pc

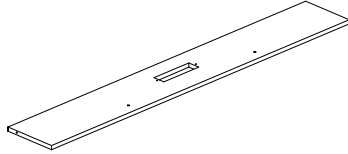

⑭ × 1pc

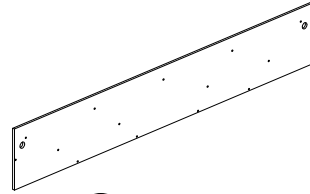

⑮ × 1pc

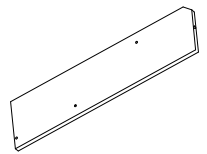

⑯ × 1pc

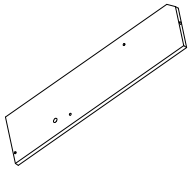

⑰ × 1pc

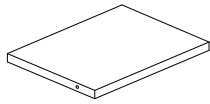

⑱ × 4pcs

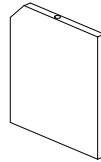

⑲ × 2pcs

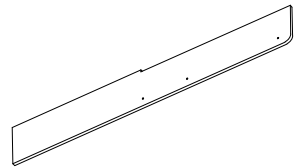

⑳ × 1pc

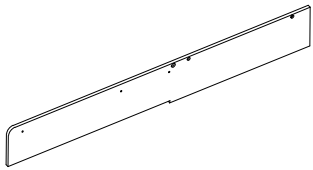

㉑ × 1pc

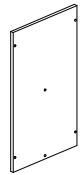



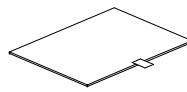





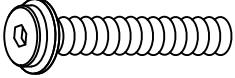
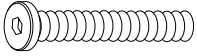
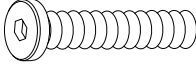
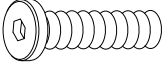
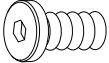
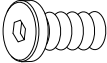

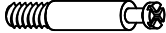
㉒ × 2pcs

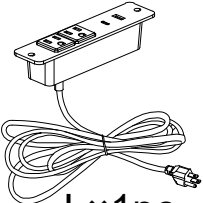
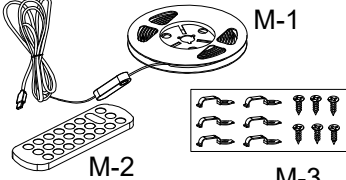

㉓ × 2pcs

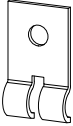
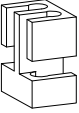
Hardware

 <p>M8×40mm A×8pcs+1pc</p>	 <p>M6×60mm B×5pcs+1pc</p>	 <p>M6×48mm C×4pcs+1pc</p>	 <p>M6×32mm D×6pcs+1pc</p>
 <p>M6×15mm E×20pcs+1pc</p>	 <p>M6×10mm F×6pcs+1pc</p>	 <p>M5×40mm G×41pcs+2pcs</p>	 <p>M6×35mm H×4pcs+1pc</p>
 <p>Ø15×10mm I×4pcs+1pc</p>	 <p>J-1 3MM 4MM J x 1pc</p>	 <p>M3.5×12mm K×2pcs+1pc</p>	 <p>L×1pc</p>
 <p>M-1 M-2 M-3 M×1pc</p>	 <p>N×1pc</p>	 <p>O×2pcs</p>	 <p>R×4pcs+1pc</p>
 <p>S×8pcs</p>			

1



M5x40mm

Gx2pcs

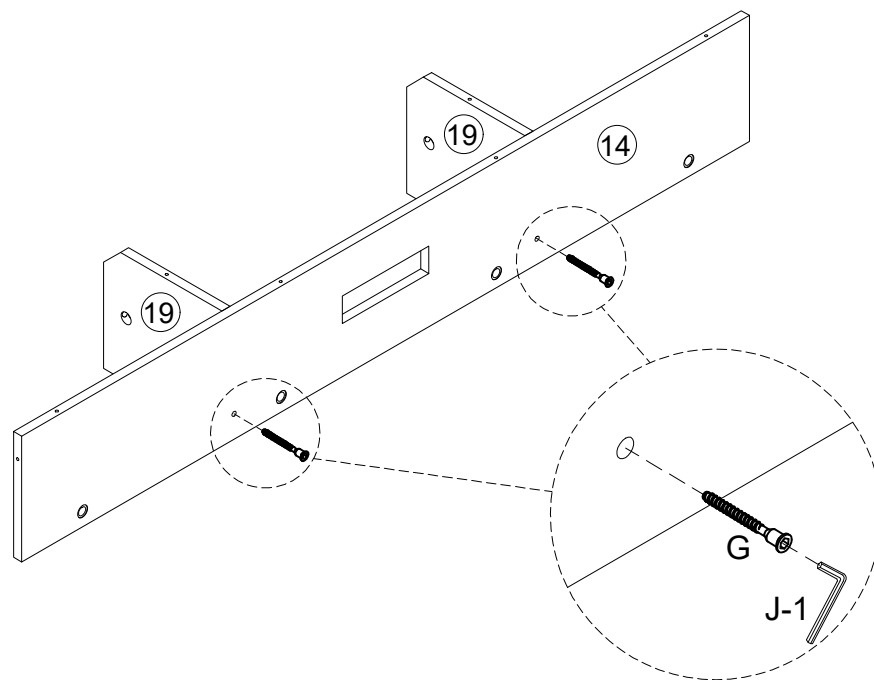

2



M5x40mm

Gx2pcs

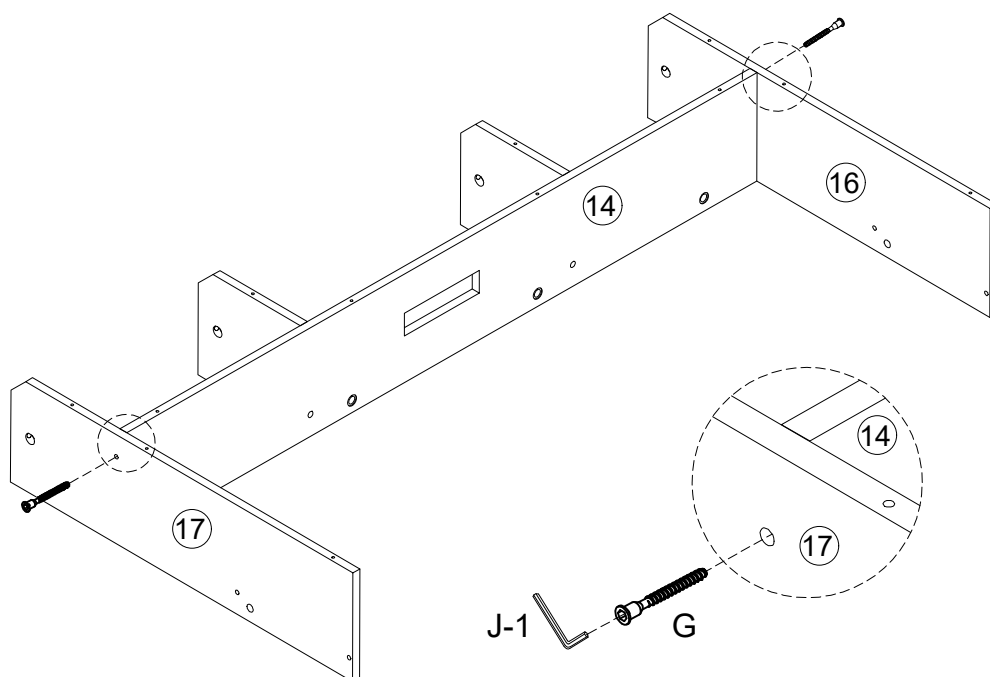

3



M5×40mm

G×4pcs

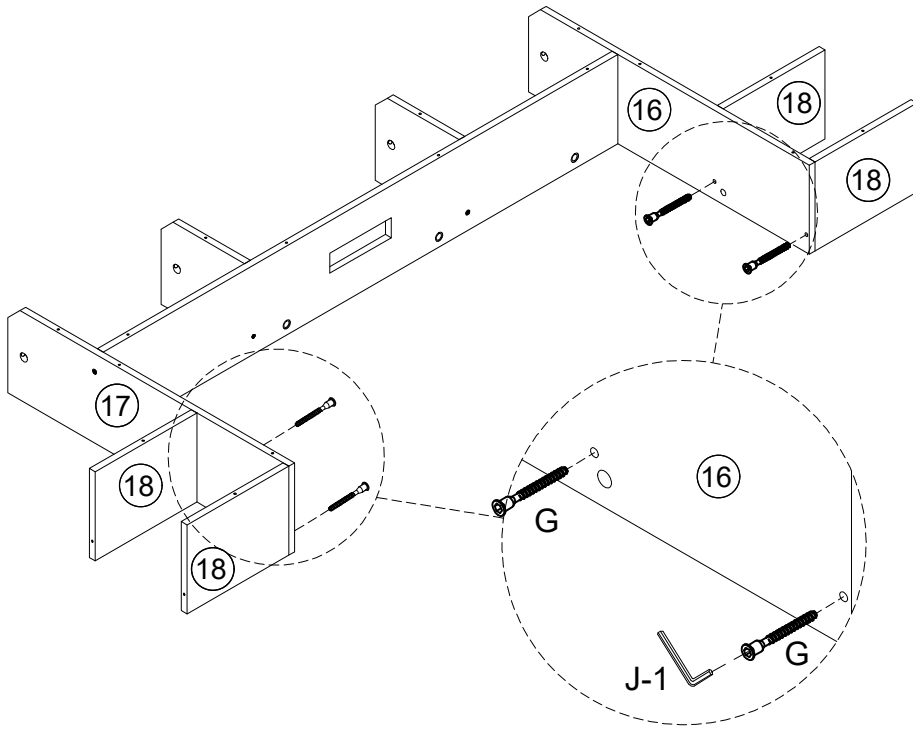

4

Step 1

Tear double-sided adhesive tape apar

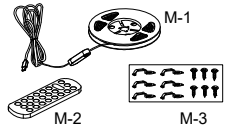

M×1pc

Step 2

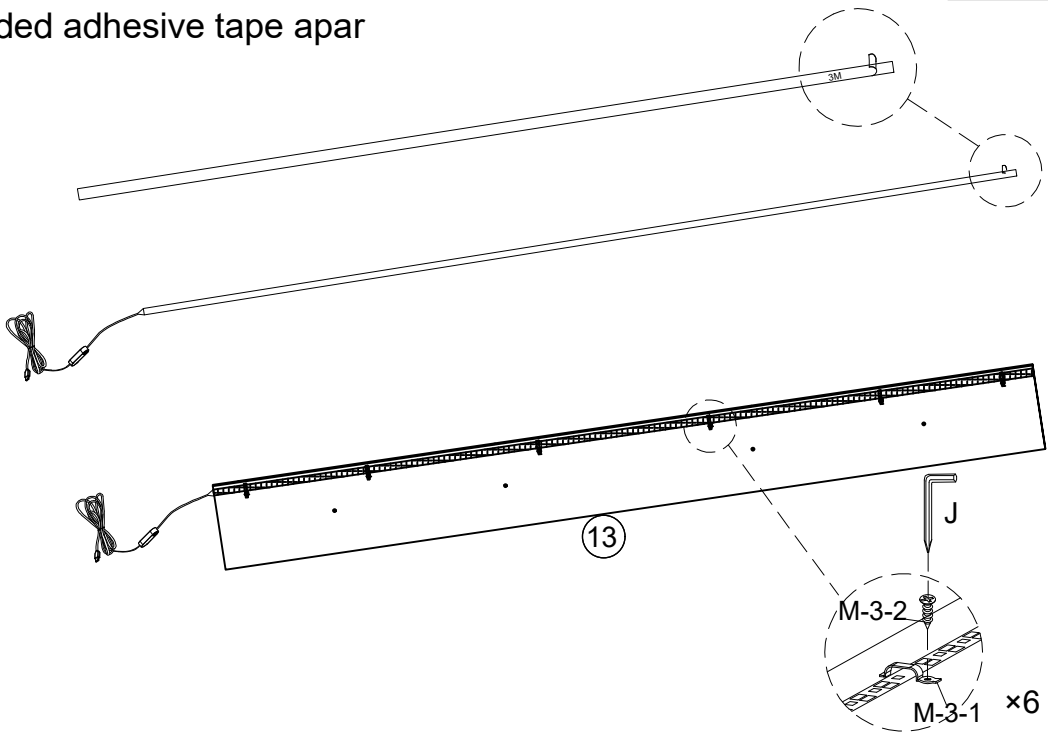

5

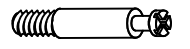

M6×35mm

H×4pcs

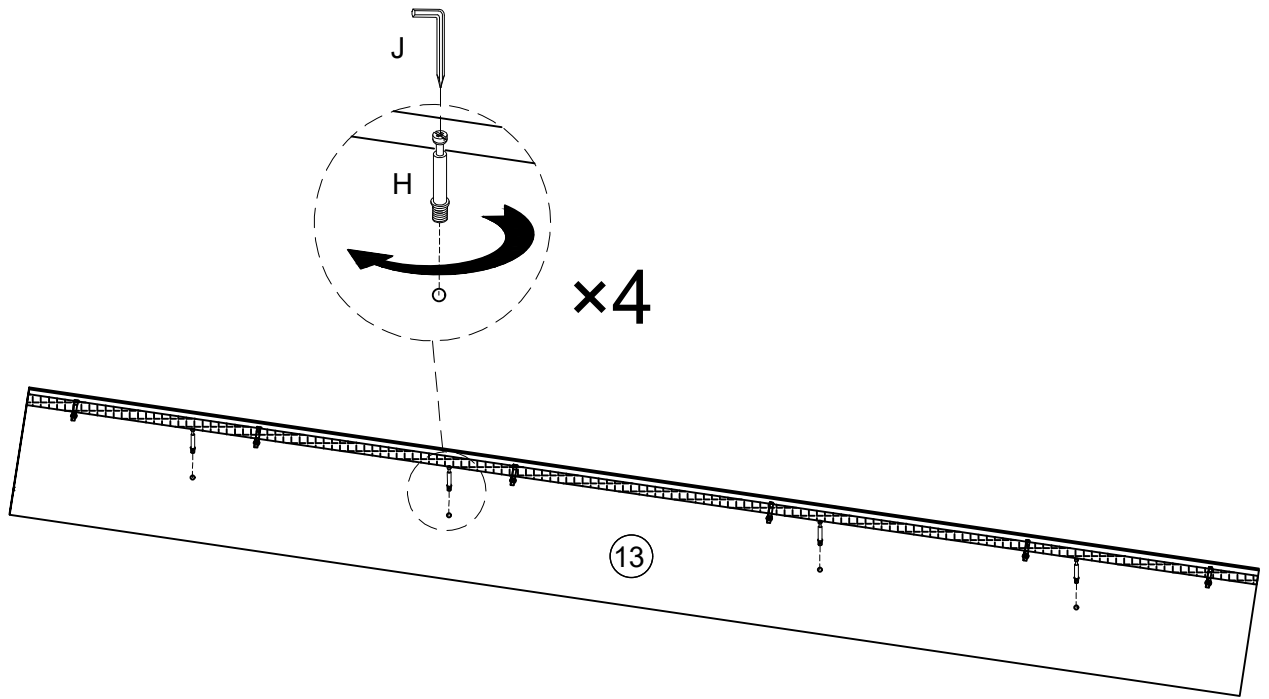

6



Ø15×10mm

I×4pcs

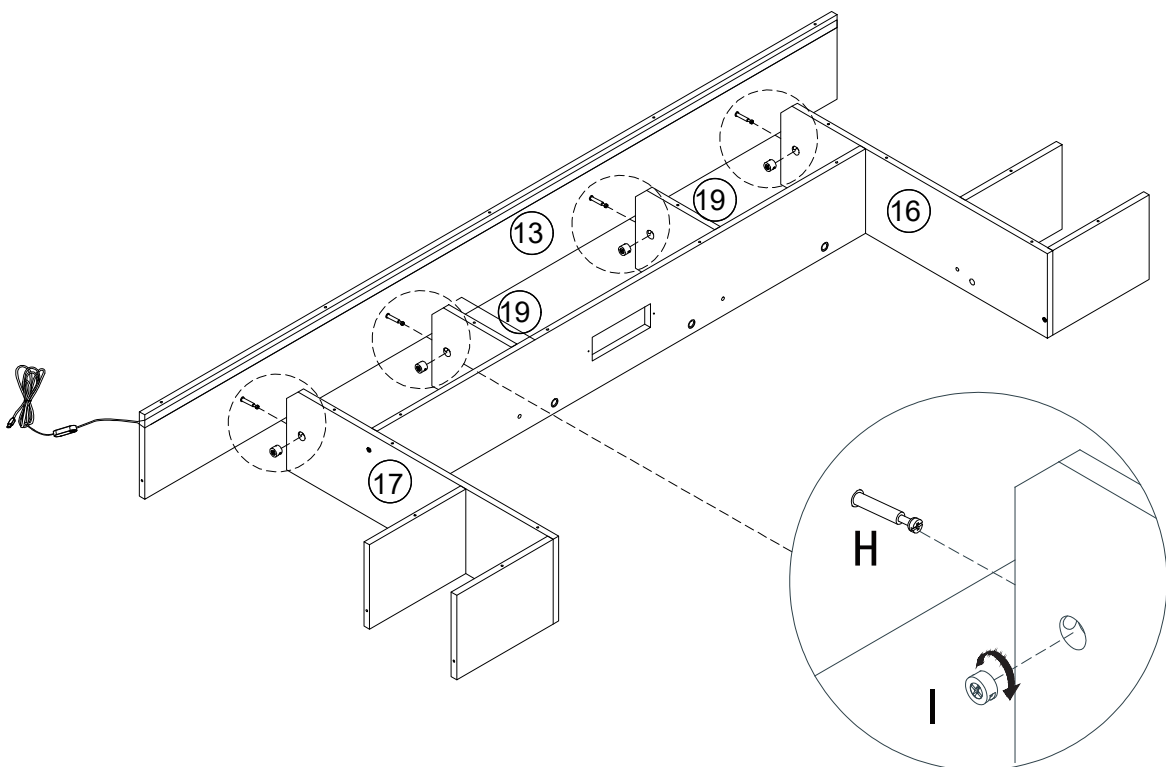

7

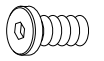

M6×10mm
F×6pcs

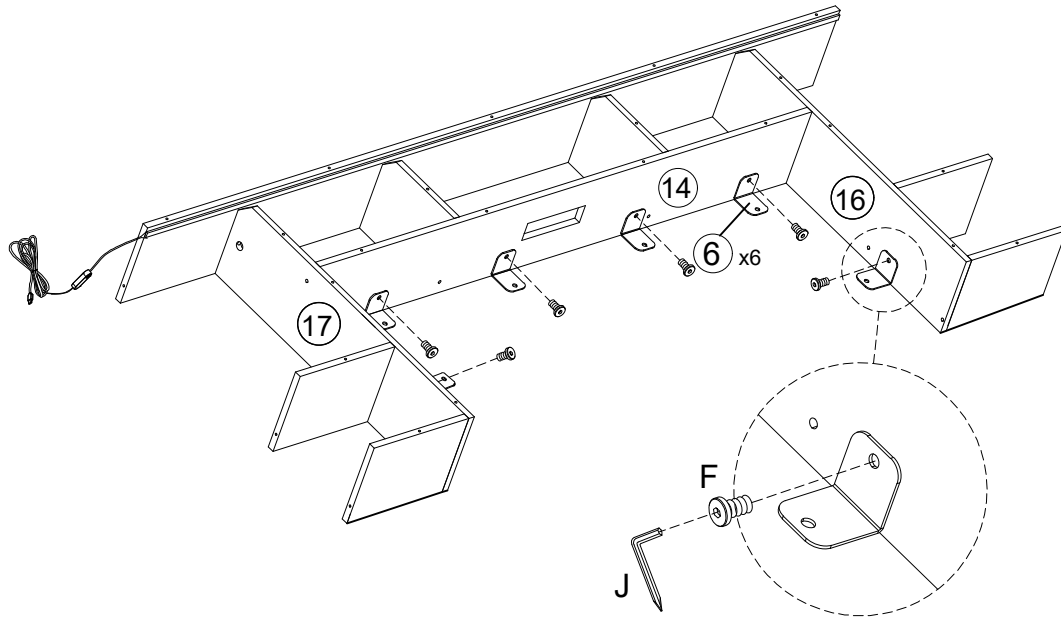

8

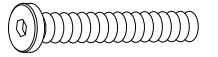

M6×60mm
B×2pcs

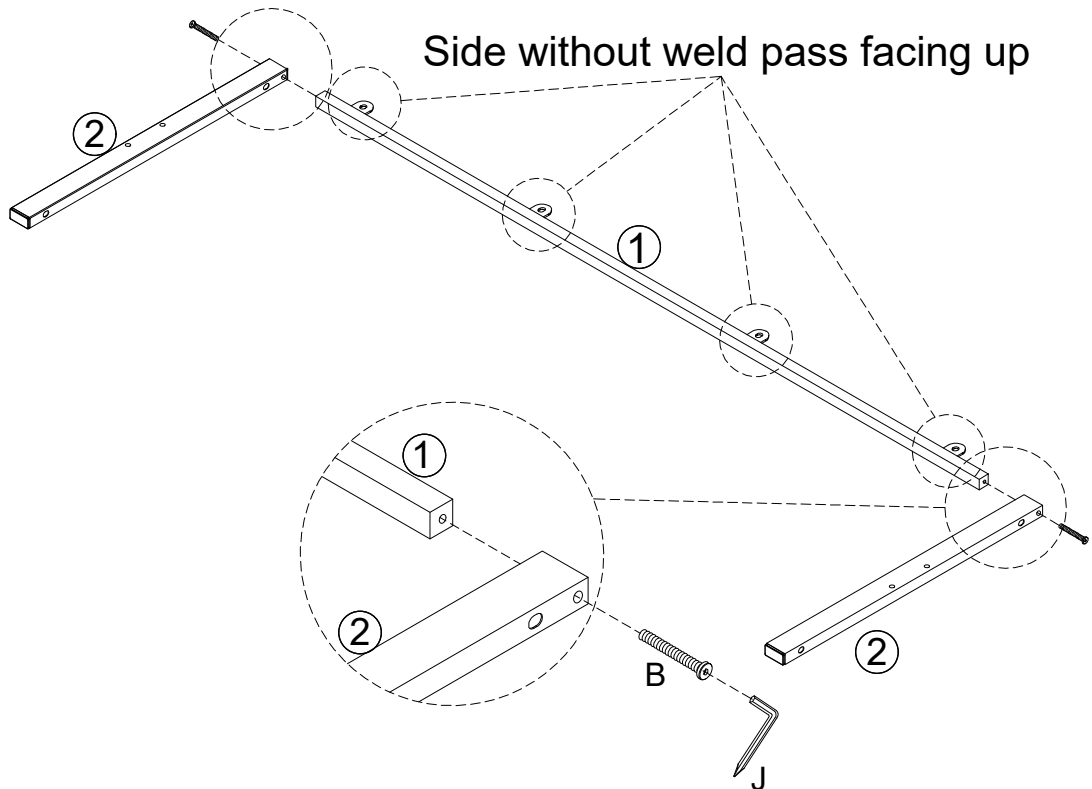

9

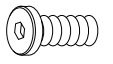

M6×15mm
E×10pcs

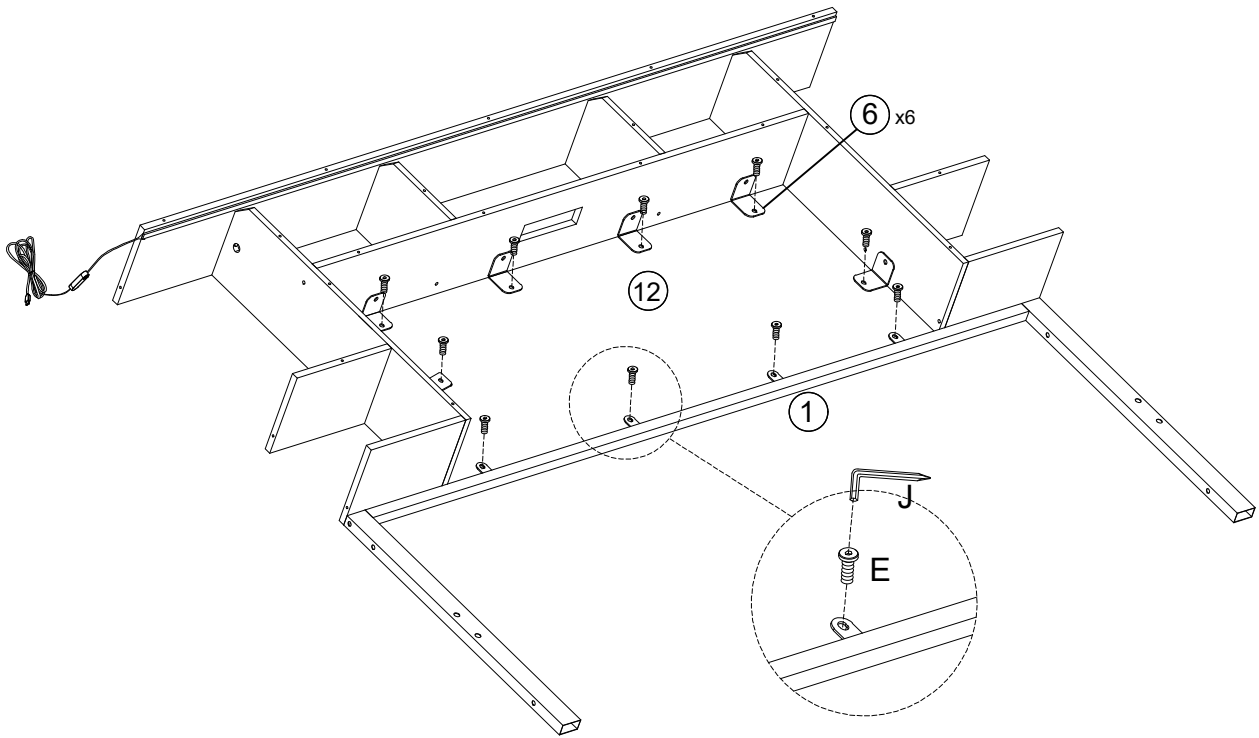

10



M5×40mm
G×13pcs

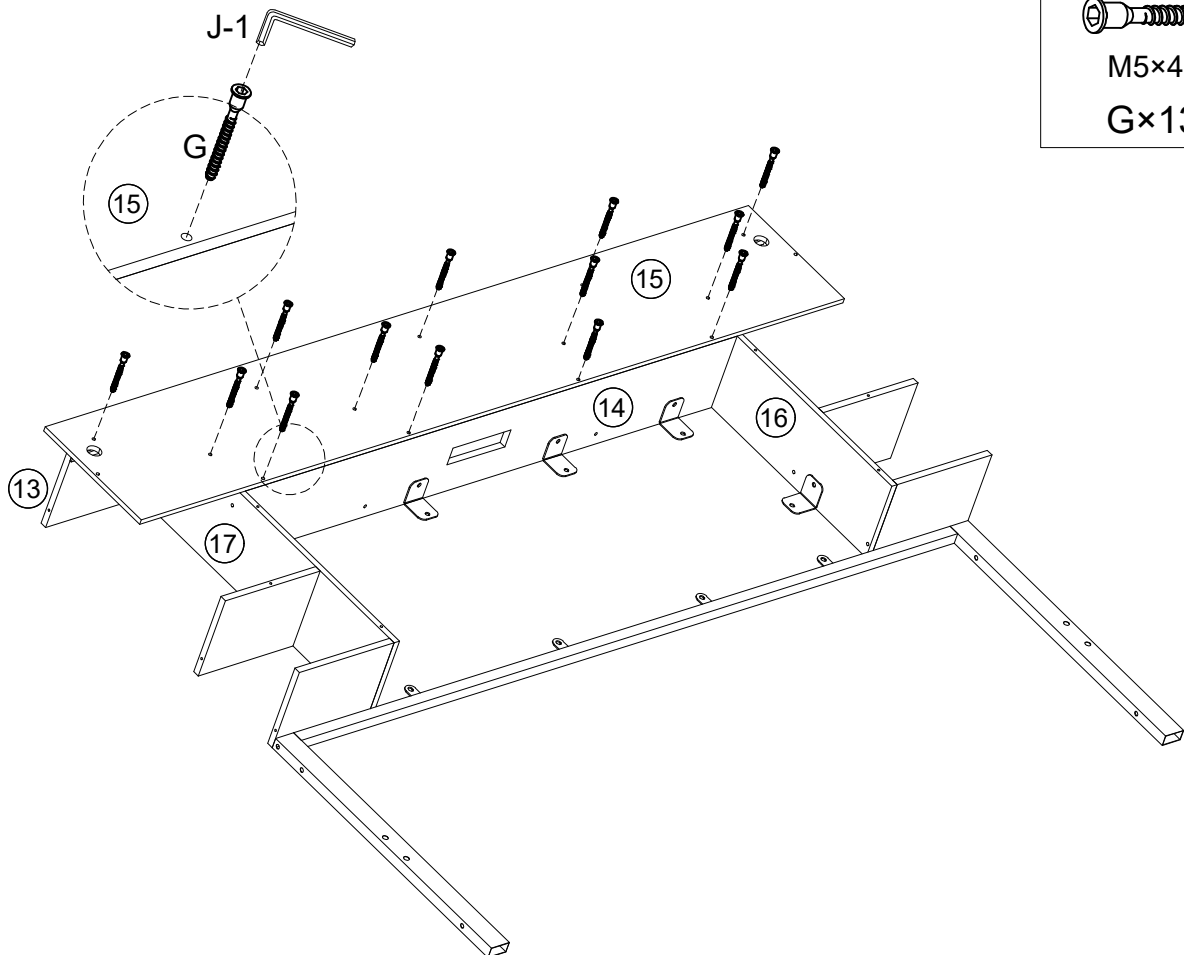

11

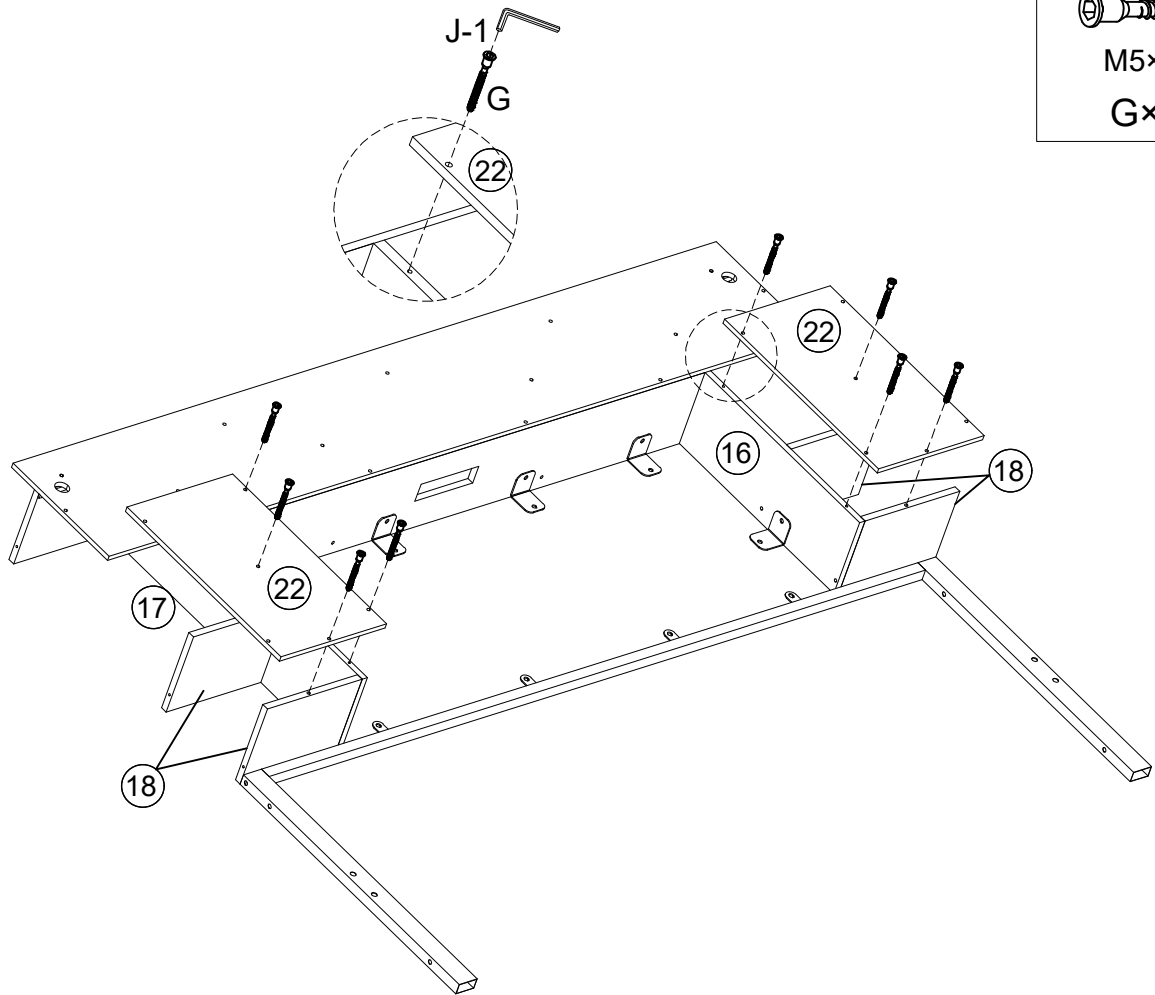

12

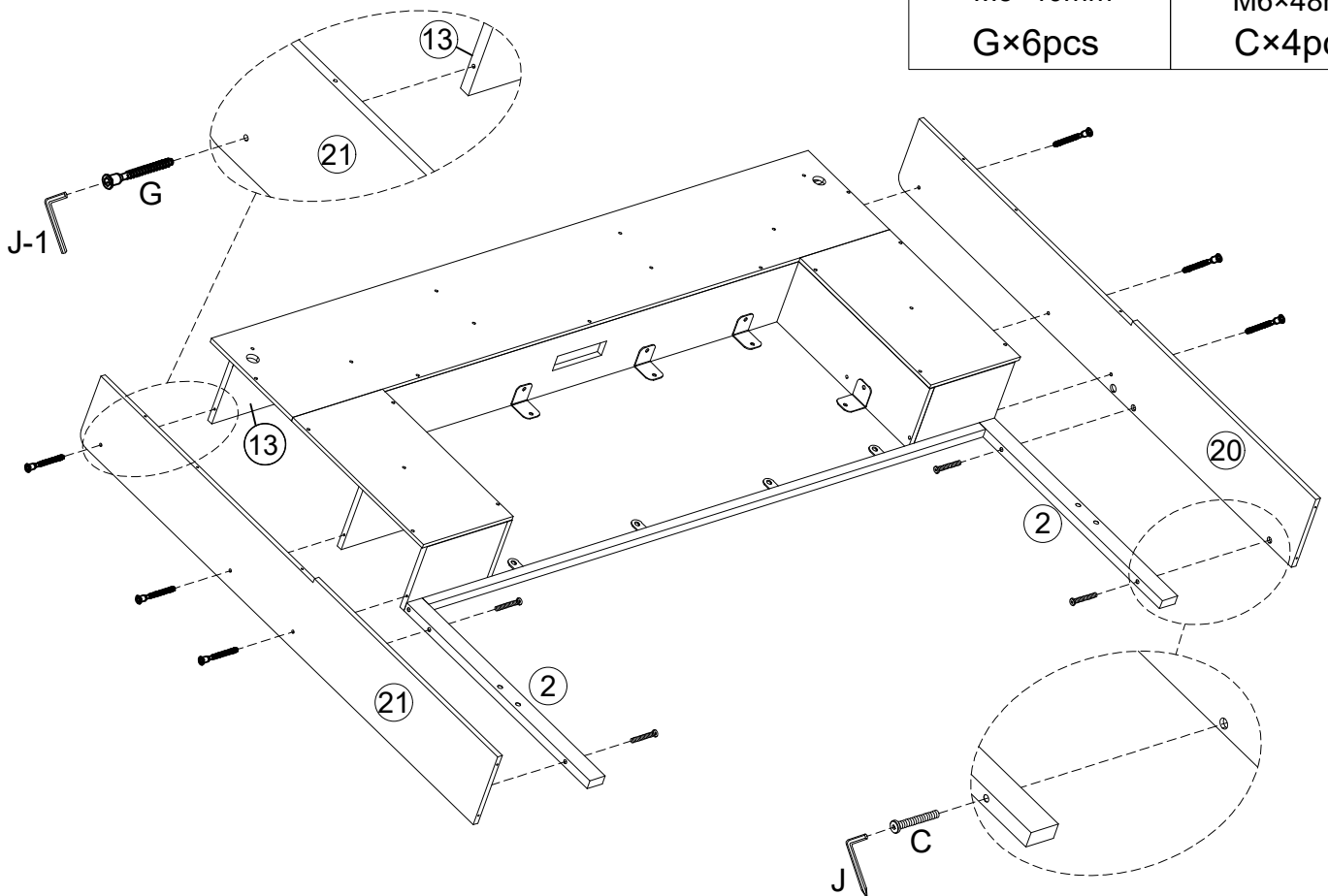

13

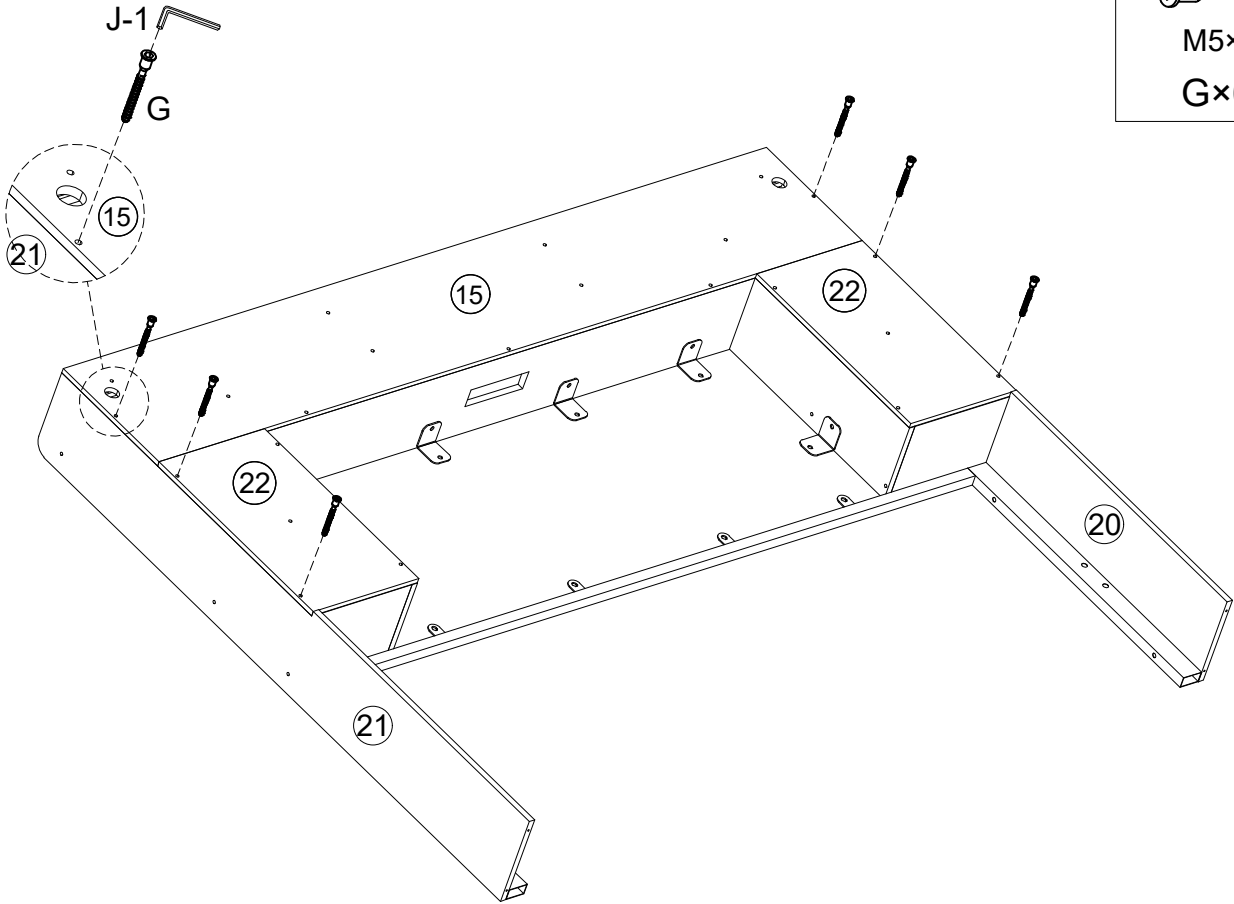

M5×40mm
G×6pcs

14

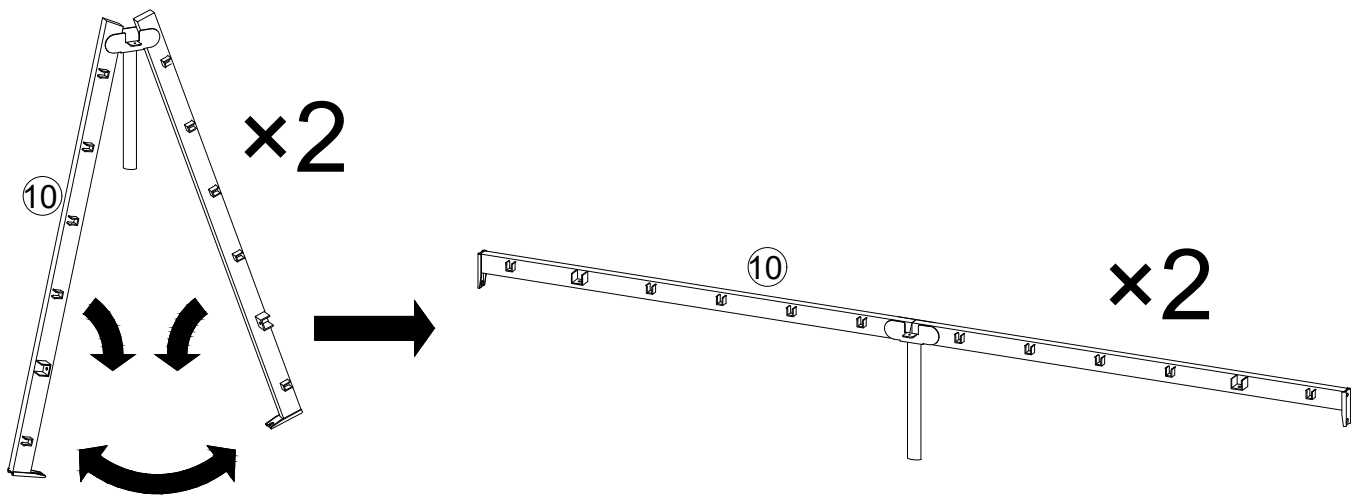

15



M8x40mm
A×4pcs

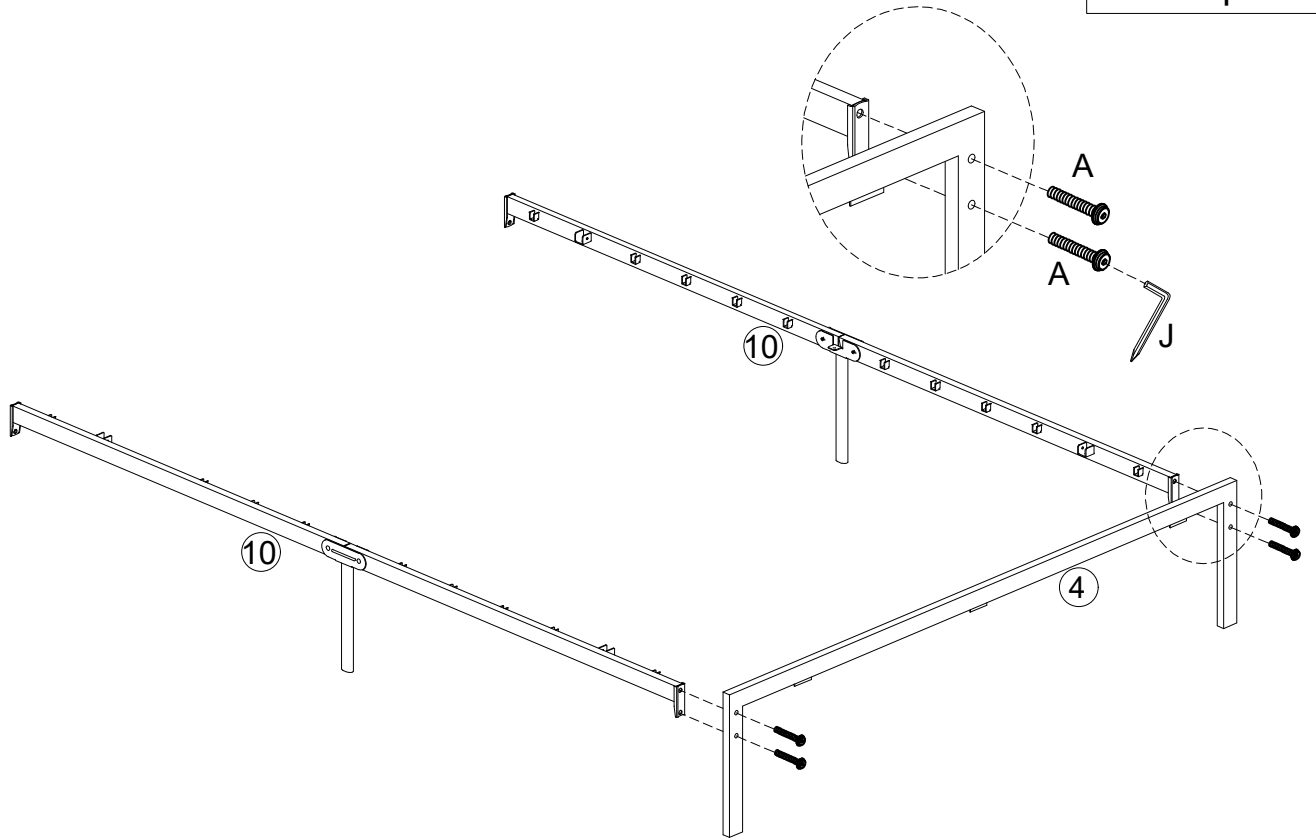

16

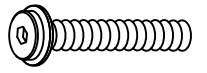

M8x40mm
A×4pcs

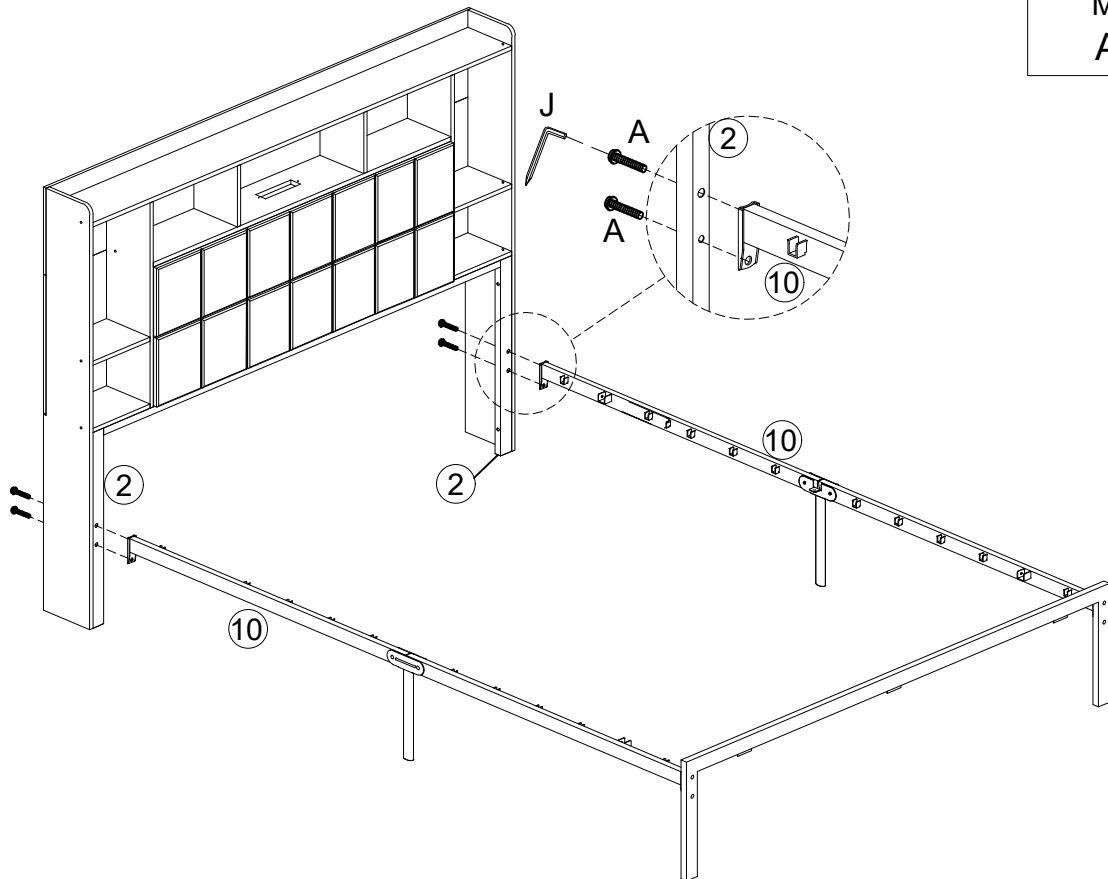

17



L×1pc



M3.5×12mm

K×2pcs

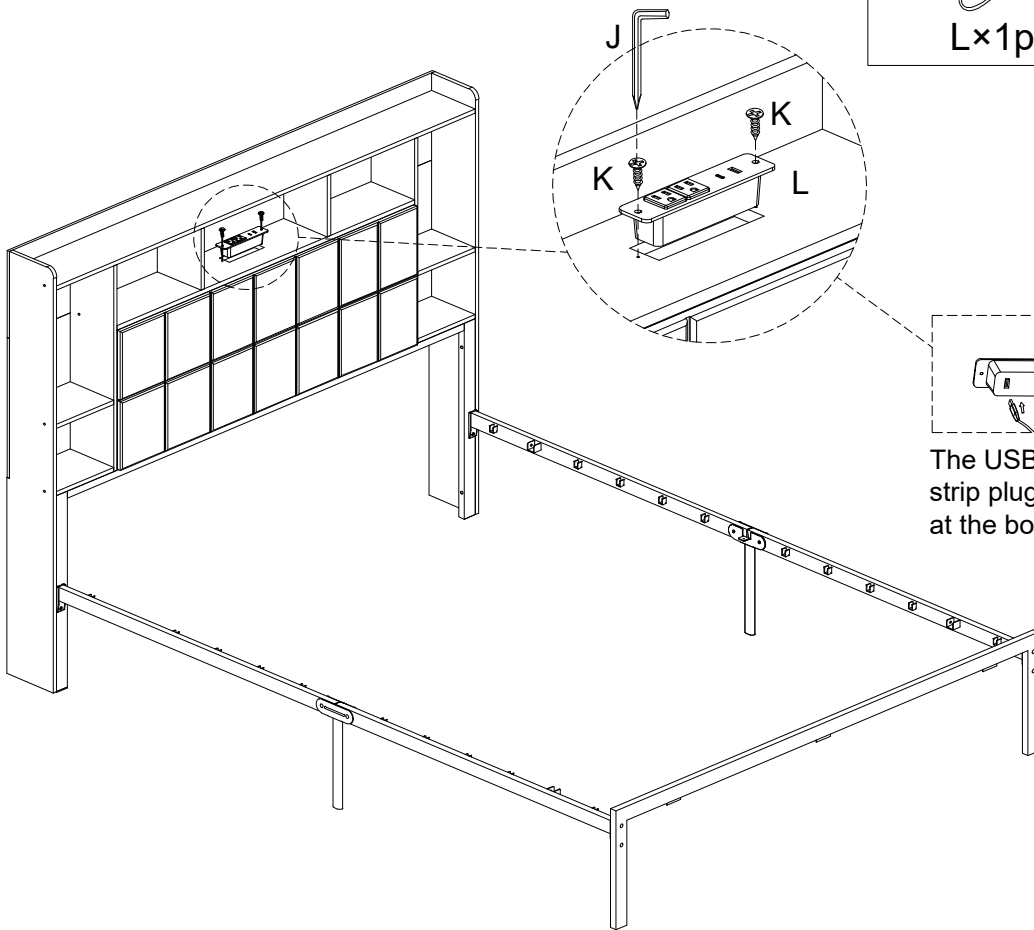

The USB port of the light strip plugs into the USB port at the bottom of the socket

18

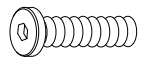

M6×32mm

D×6pcs

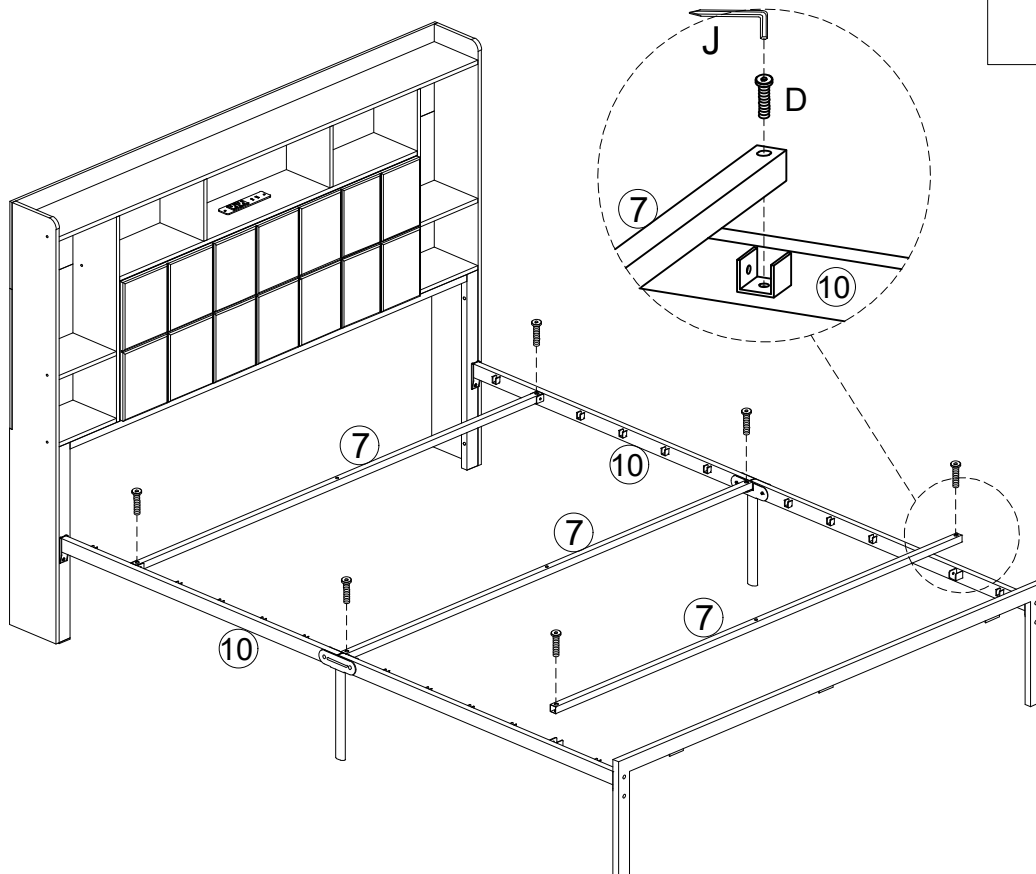

19

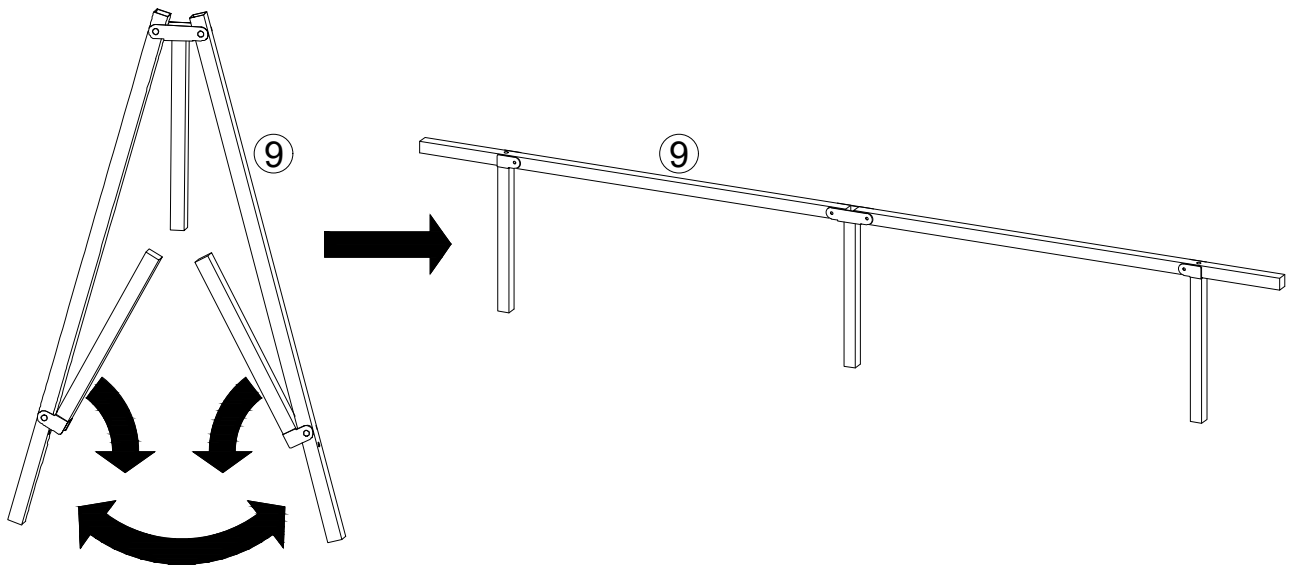

20

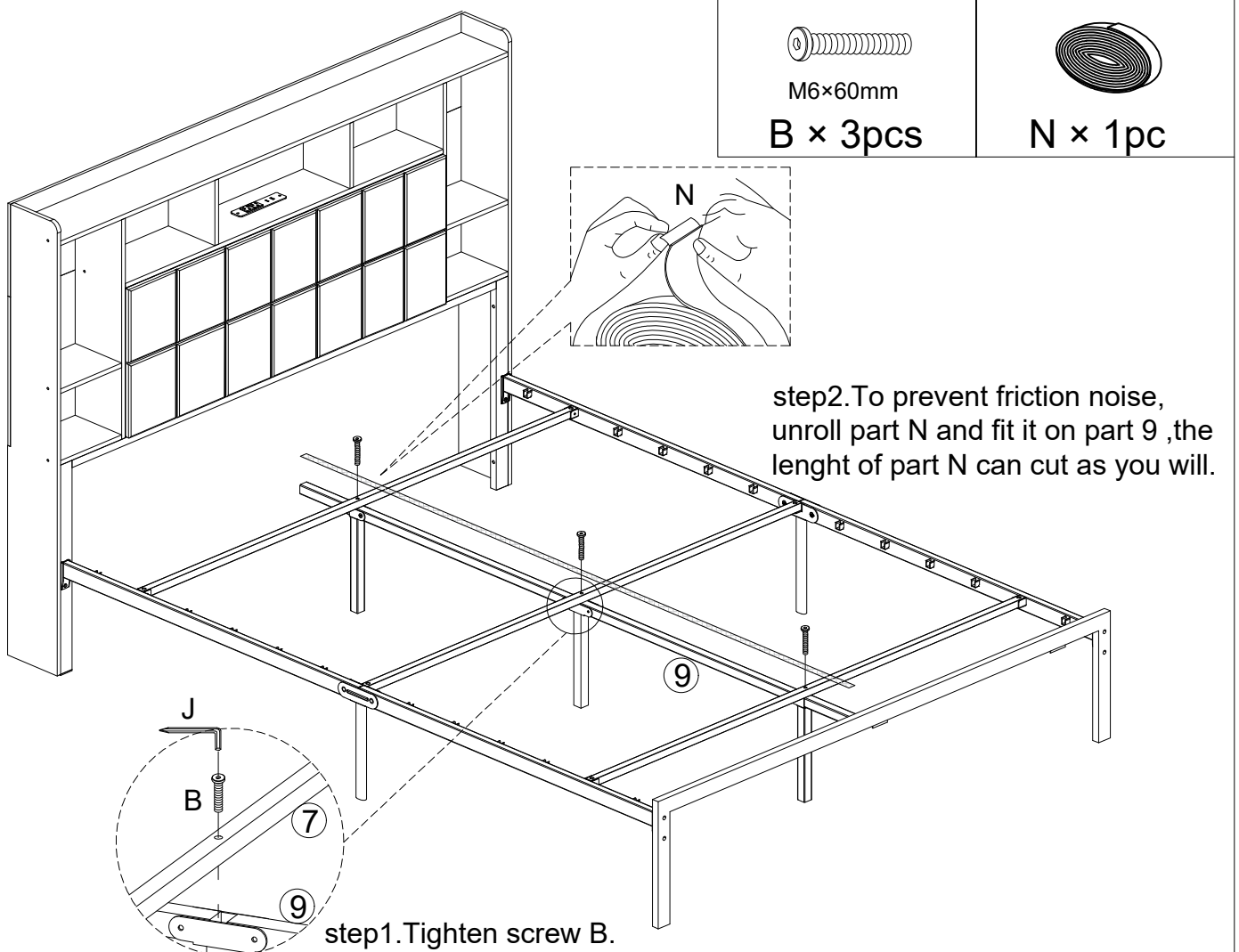

21

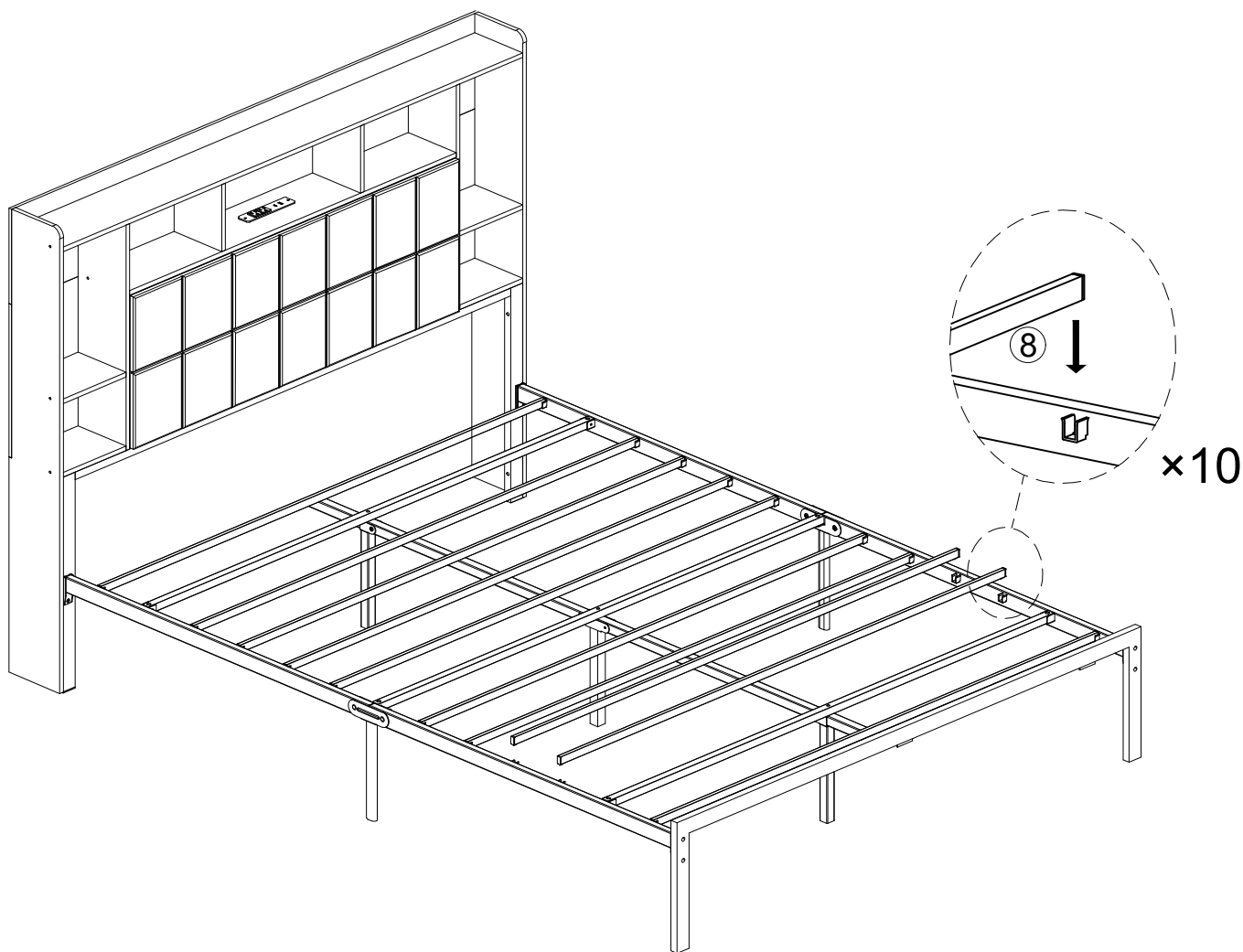

22



R \times 4pcs

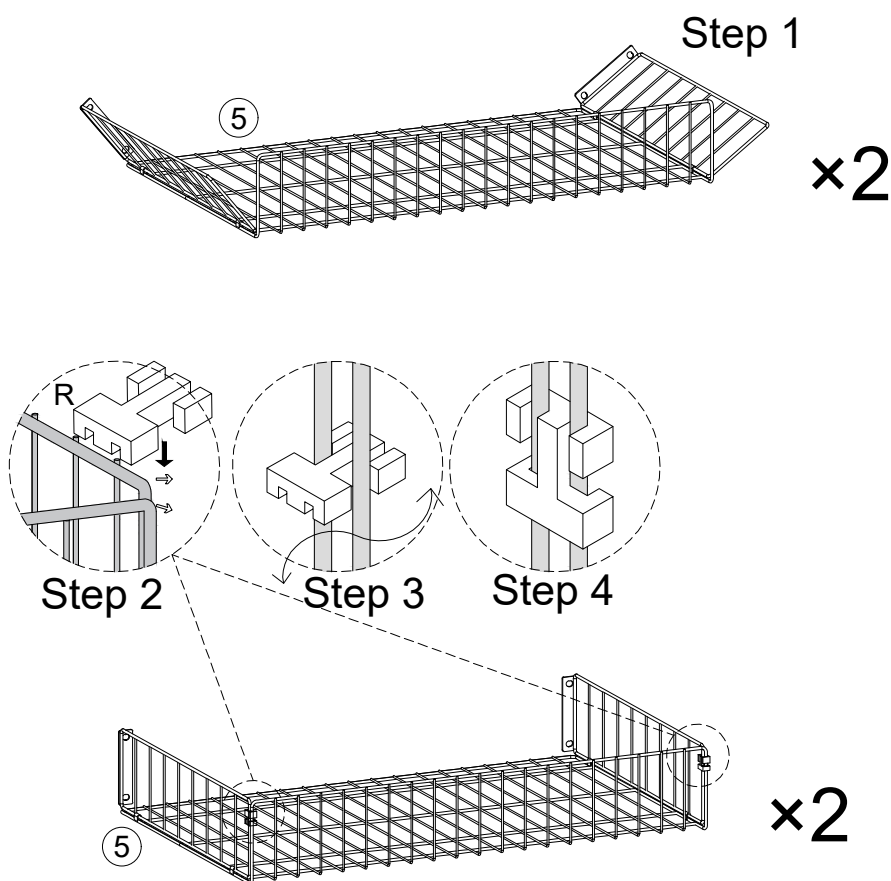

23



M6×15mm
E×10pcs



O × 2pcs

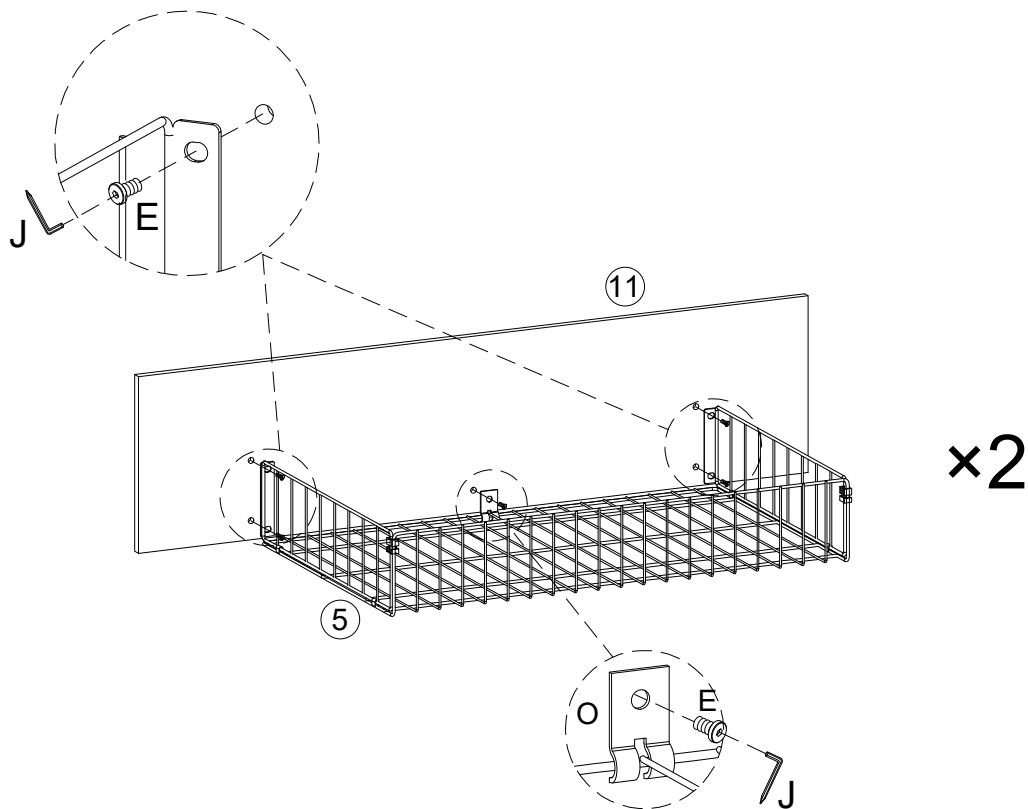

24



S × 8pcs

Clamp the wire with the opening of the front end of the wheel and press down to tighten the wire.

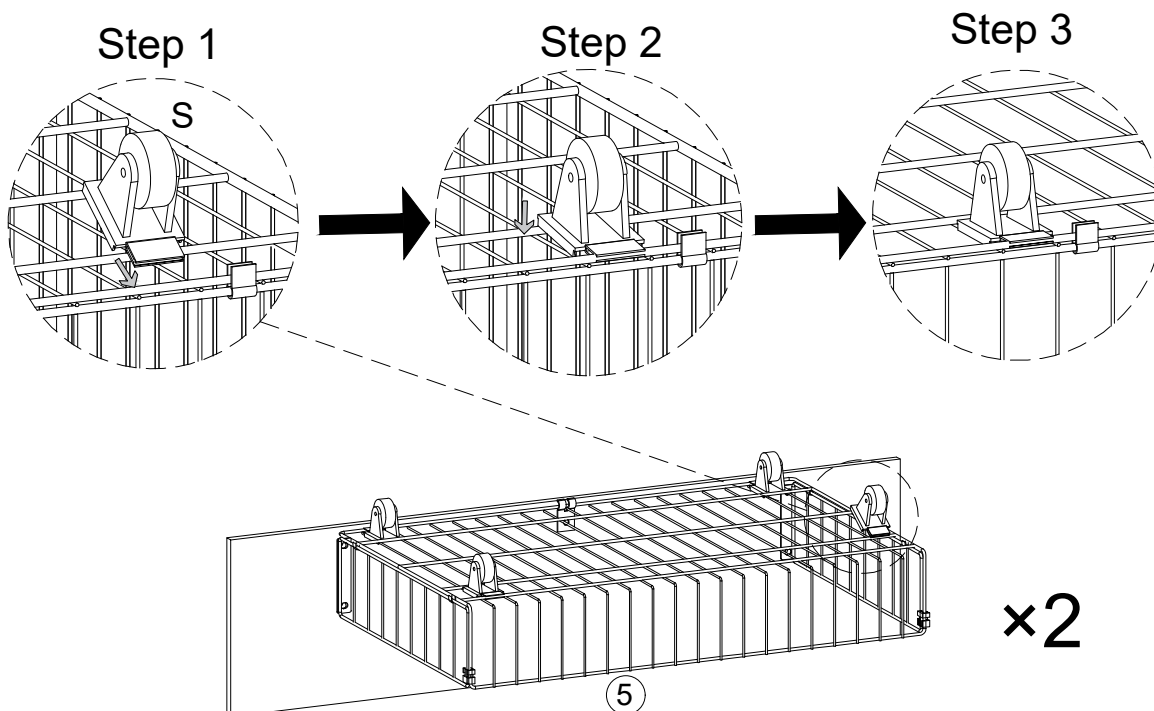

25

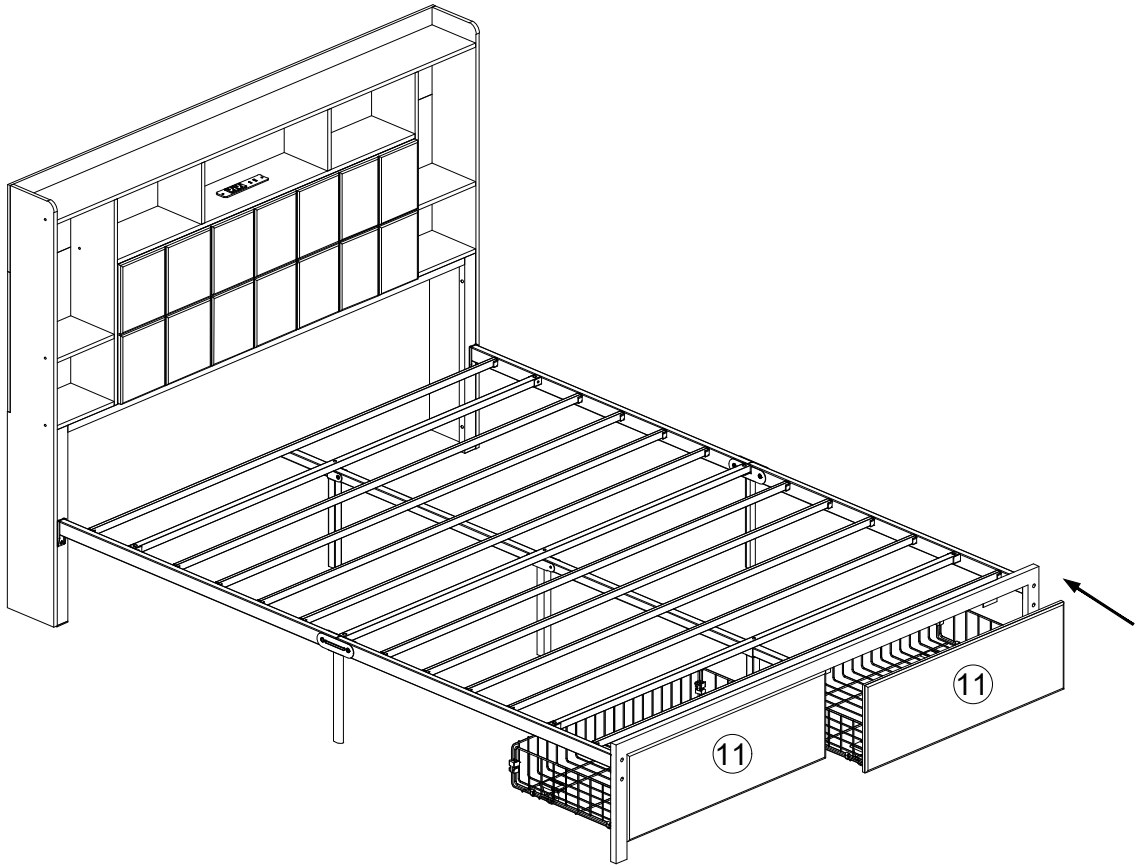

26

