

ASSEMBLY INSTRUCTIONS

Customer Service : cs@nbrehome.com

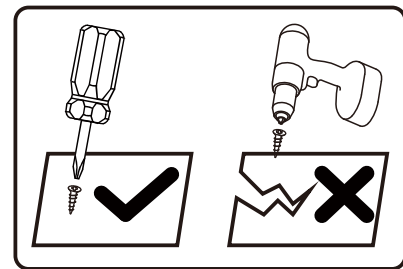
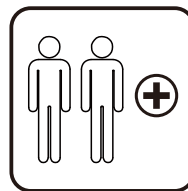
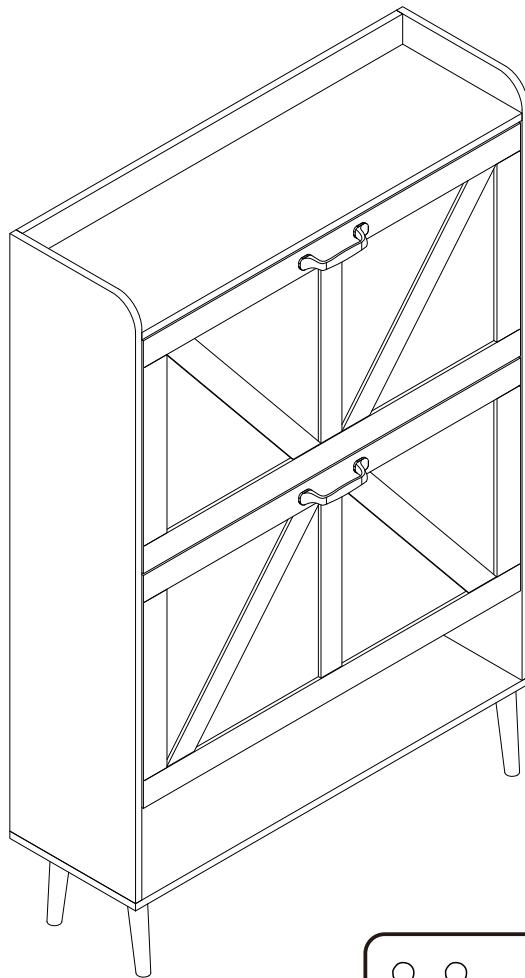

Tools Recommended

THIS INSTRUCTIONS CONTAINS IMPORTANT SAFETY INFORMATION.
PLEASE READ BEFORE ASSEMBLY AND KEEP FOR FUTURE REFERENCE.

Need Parts or Assistance? Email us : cs@nbrehome.com

IMPORTANT NOTICE

-This product contains small components, please ensure that they are kept away from small children.

-THIS INSTRUCTIONS CONTAINS IMPORTANT SAFETY INFORMATION.
PLEASE READ BEFORE ASSEMBLY AND KEEP FOR FUTURE REFERENCE.

-Read each step carefully. It is very important that each step of instruction is performed in the correct order. If these steps are not followed in sequence, assembly difficulties will occur.

-Make sure all parts are included. Most parts are labelled or stamped on the raw edge.

-Work in spacious area, preferably on a carpet, near the place the unit will be used.

-Do not use power tools to assemble your furniture. Power tools may strip or damage the parts.

-Move your new furniture carefully, with two people lift and carry the unit to it's new location.

-Never push, drag or pull your furniture (especially on carpet)



PLEASE DO NOT RETURN PRODUCT TO US IMMEDIATELY









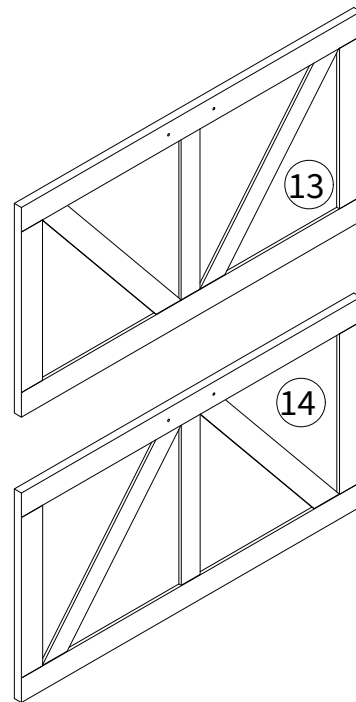
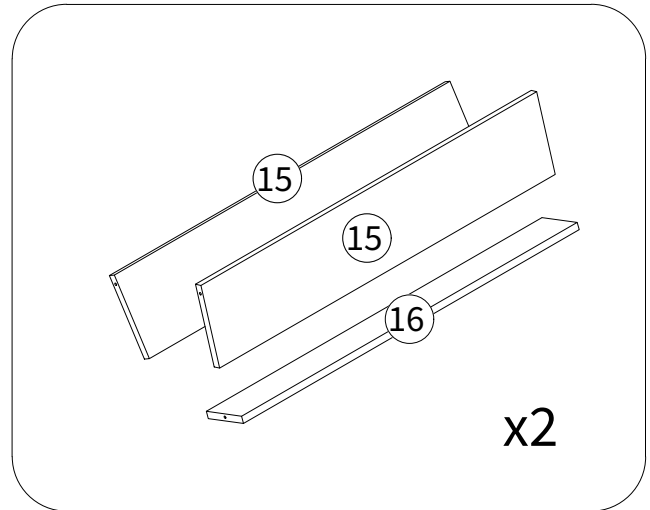
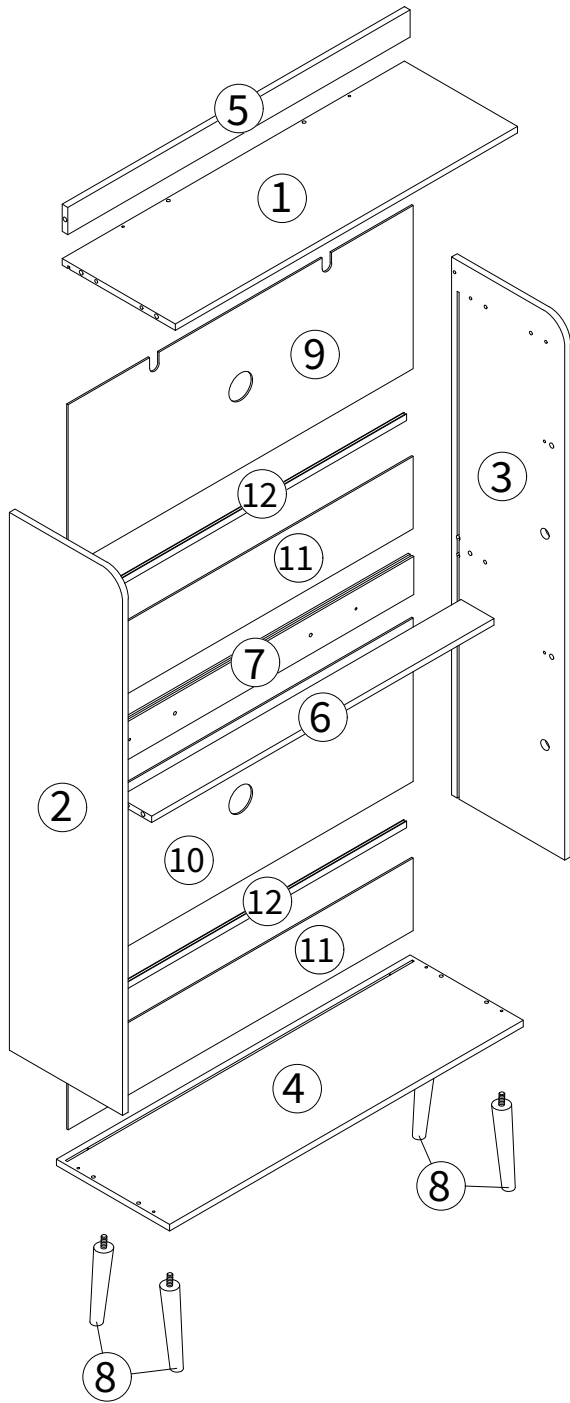









If a part is missing or damaged, email our customer service.
We will gladly ship your replacement parts FREE of charge.

Need Parts or Assistance? Email us : cs@nbrehome.com

For Prompt, reliable service, please have your assemble instruction ready

 WARNING	
	Children have died from furniture tipover. To reduce the risk of furniture tipover: <ul style="list-style-type: none">• ALWAYS install anti-tip device provided.• NEVER put a TV on this product.• NEVER allow children to stand, climb or hang on any drawers, doors, or shelves.• NEVER open more than one drawer at a time.• Place heaviest items in the lowest drawers.
	<p>This is a permanent label. Do not remove!</p>



 A x 2	 B x 2	 C x 4	 D x 4
 E x 4	 F x 10 M6x35mm	 G x 16 M6x30mm	 H x 10 M4x35mm
 I x 10 M15x10mm	 J x 2	 K x 24 M4x12mm	 L x 4
 M x 8	 N x 8 M3x16mm	 O x 28 M4x12mm	 P x 2
 Q x 4 M4x18mm	 R x 2	 S x 4 M4x8mm	

Step 1

First use hammer to fix part (D) to panel ② and ③, and then use screw (O) to lock part (E) to them, positions as shown below.

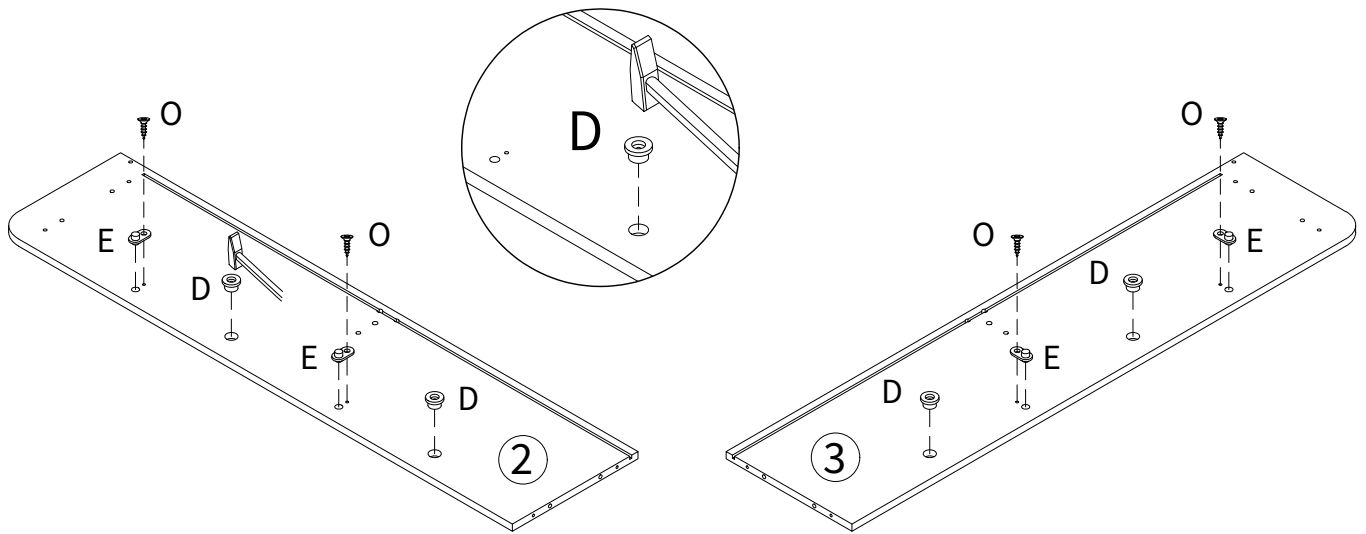

Step 2

Lock part (F) into panel ② and ③, positions as shown below.

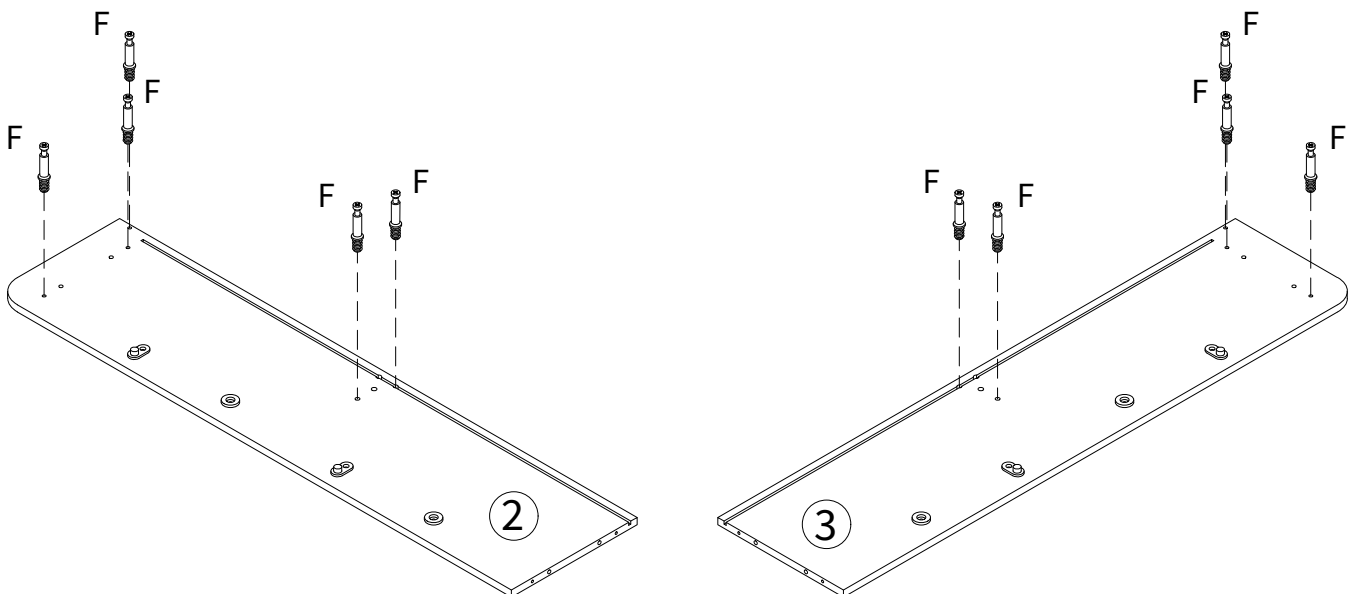

Step 3

Insert the dowels (G) into panel ⑤ and use screw (H) to lock panel ① to panel ⑤. Positions as shown below.

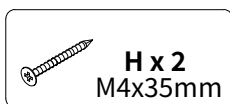
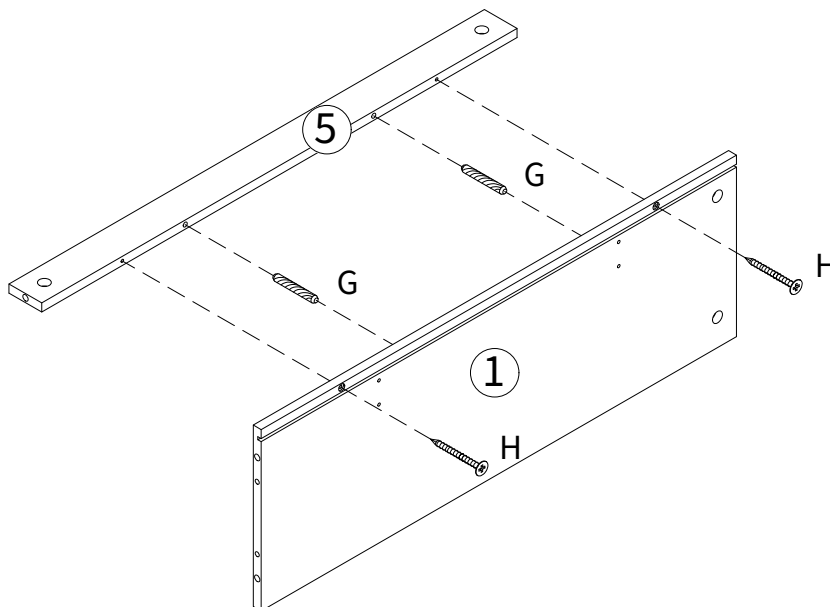

Step 4

Insert the dowels (G) into panel ⑥ and use screw (H) to lock panel ⑦ to panel ⑥. Positions as shown below.

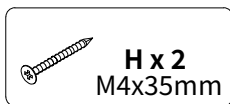
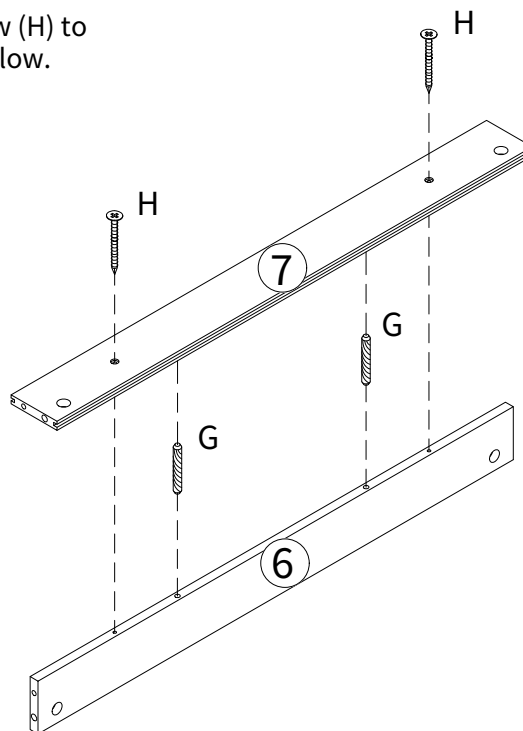

Step 5

Insert the dowels (G) into panel ② and assemble panel ① ⑤ ⑥ ⑦ to panel ②, then put part (I) to the holes and use a flat-blade screwdriver to turn it clockwise to tighten. Positions are as shown below.

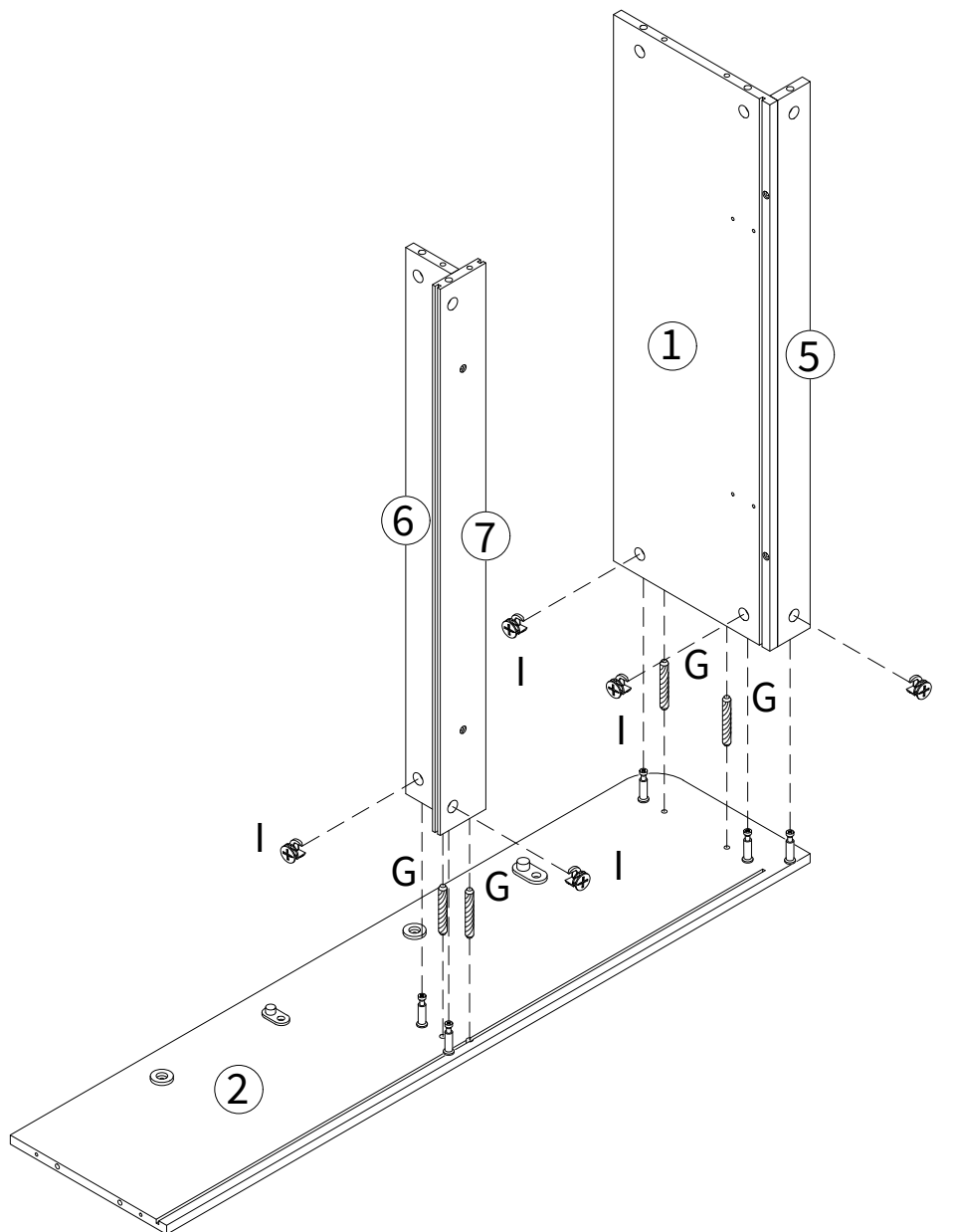

G x 4
M6x30mm



I x 5
M15x10mm

Step 6

Connect panel ⑨ and ⑪ with rail ⑫, and then insert along the slot. Positions are as shown below.

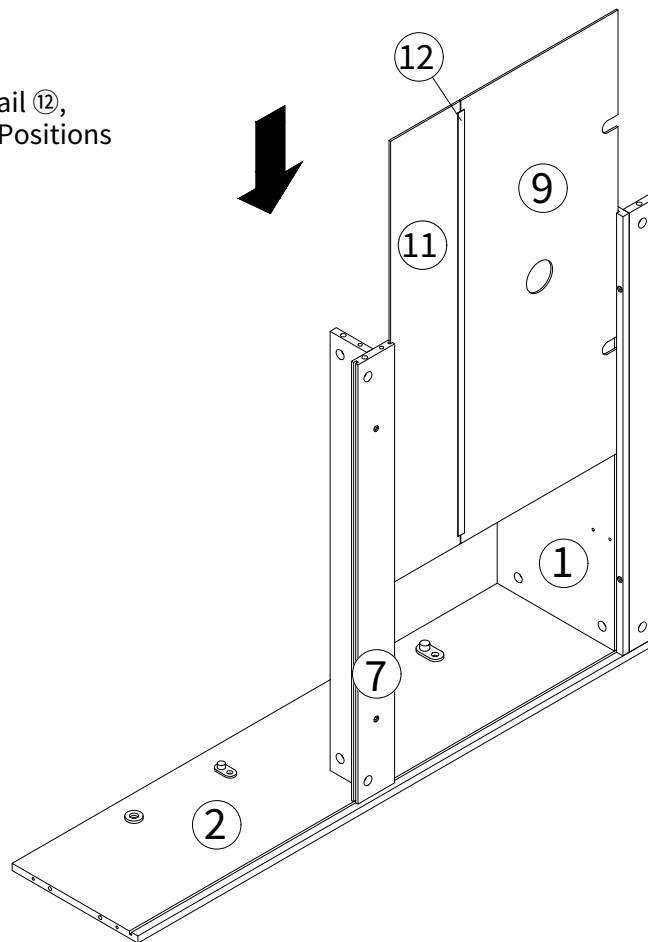

Step 7

Use screw (K) to lock part (J) to panel ①. Positions are as shown below.

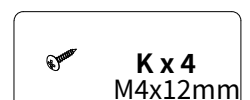
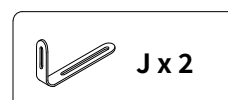
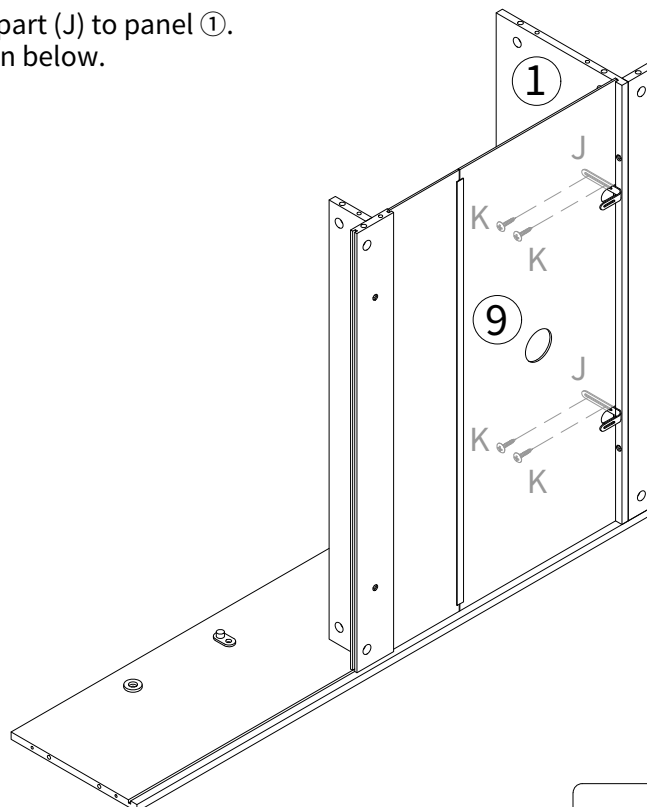

Step 8

Insert the dowels (G) into panel ① ⑥ ⑦ and connect panel ③ with panels ① ⑤ ⑥ ⑦, then put part (I) to the holes and use a flat-blade screwdriver to turn it clockwise to tighten. Positions are as shown below.

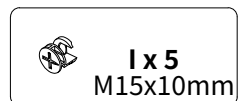
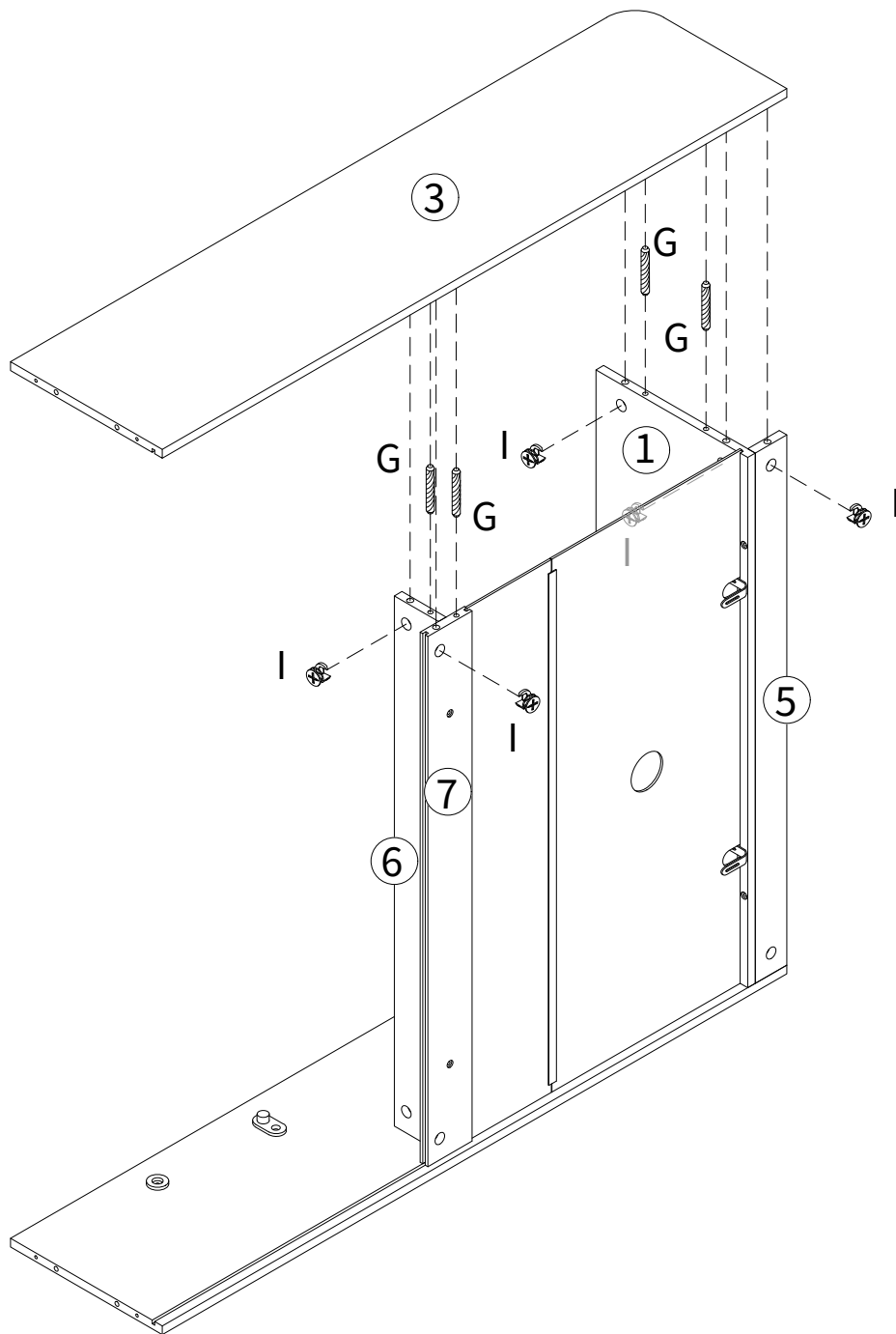

Step 9

Connect panel ⑩ and ⑪ with rail ⑫, and then insert along the slot. Positions are as shown below.

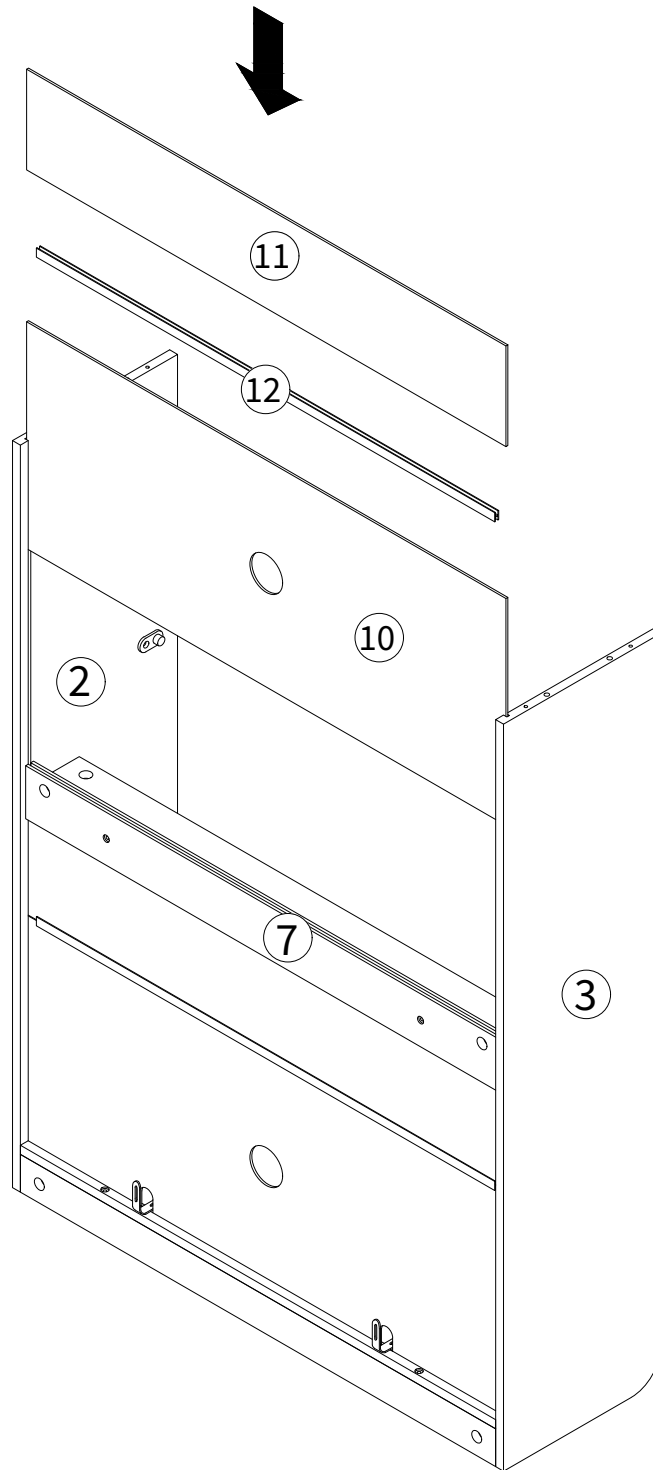

Step 10

Insert the dowels (G) into panel ② and ③, and use screw (H) to lock panel ④ to panel ② and ③. Positions as shown below.

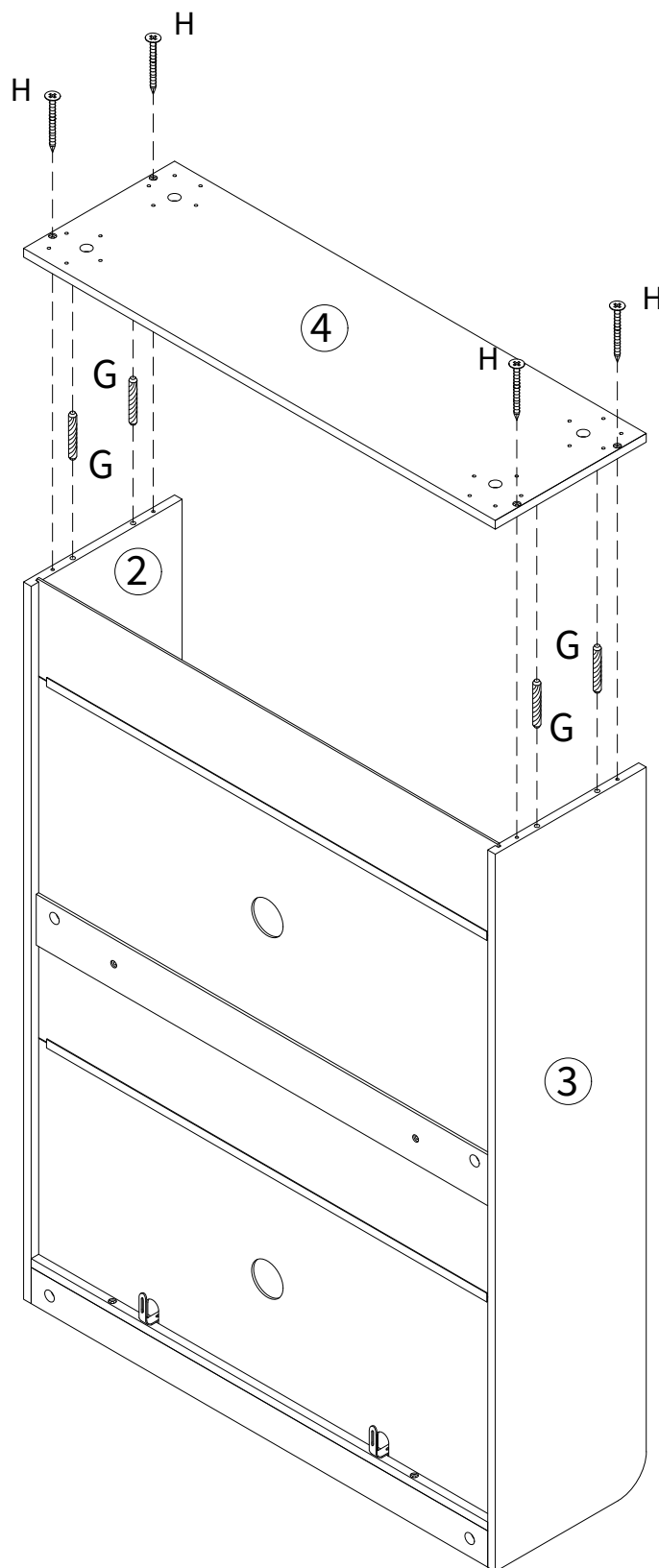

Step 11

Lock part (L) to panel ④ by using screw (K). Positions are as shown below.

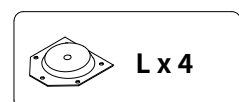
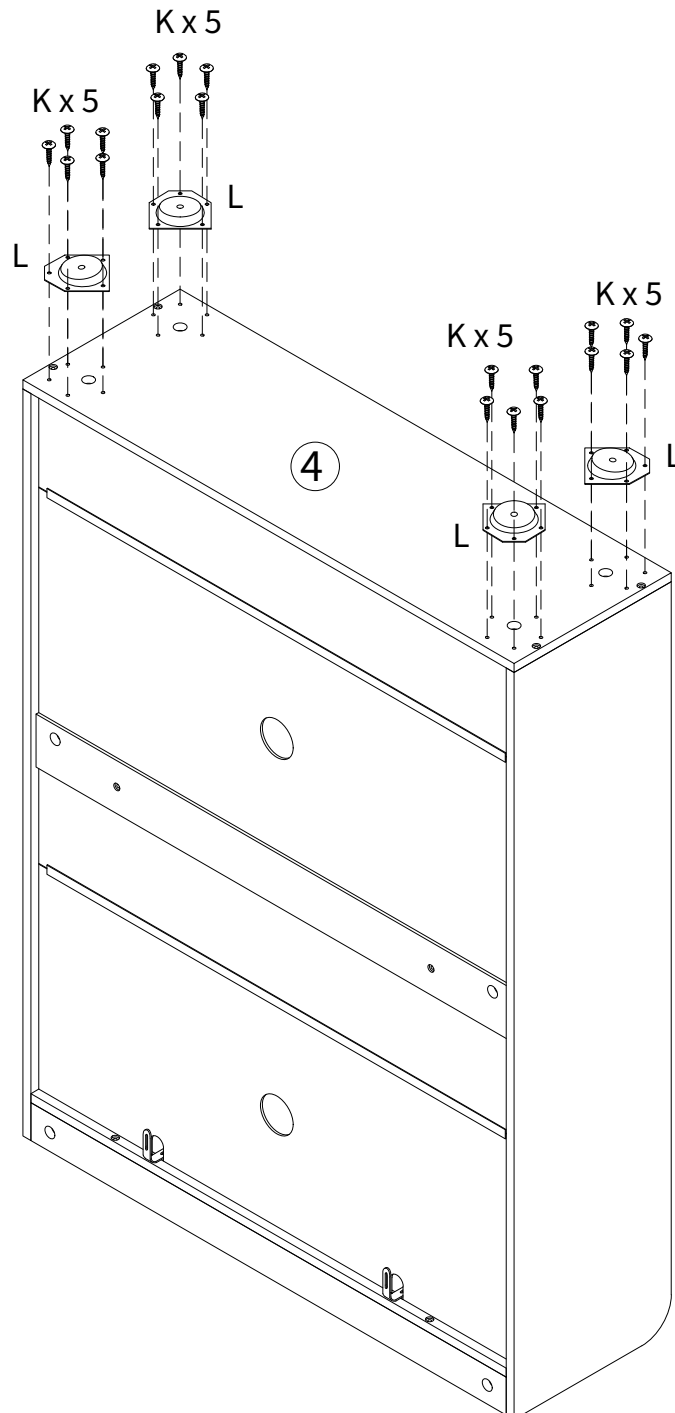

Step 12

Assemble feet ⑧ to the positions as below shown.

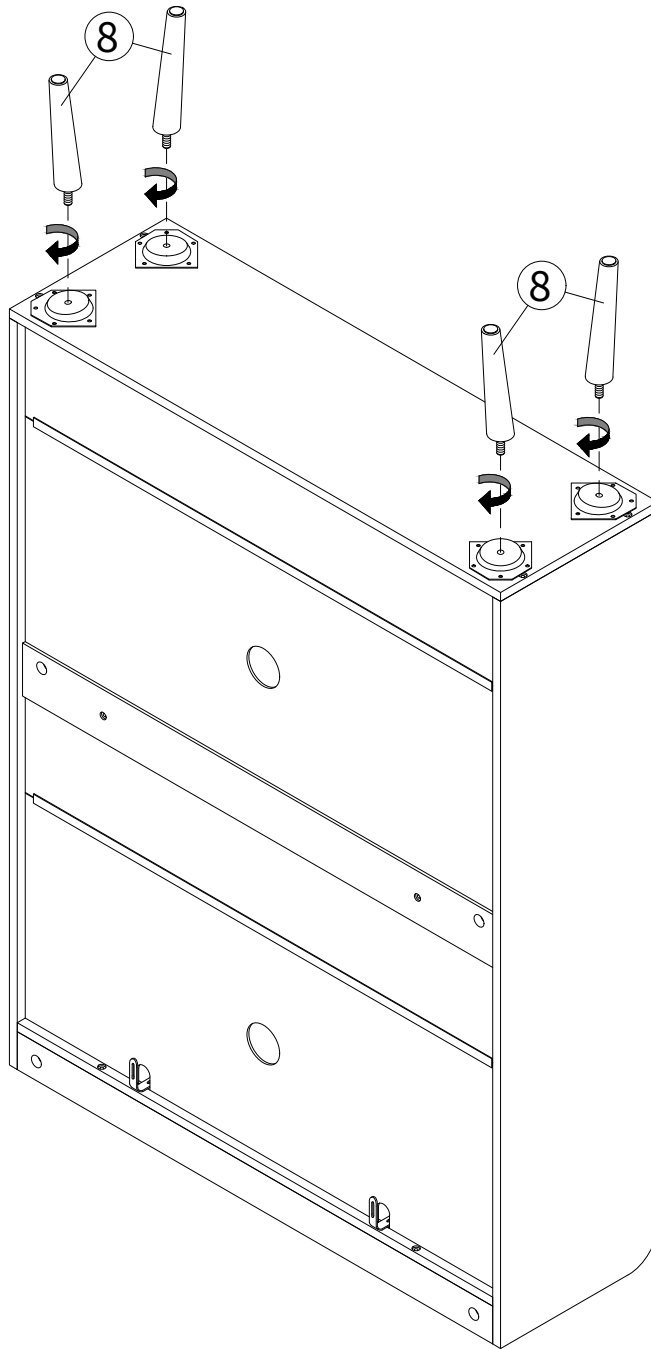

Step 13

Assemble part (M) to the corners and use screw (N) to lock them. Positions are as shown below.

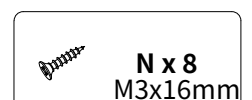
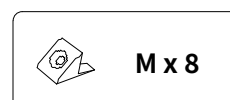
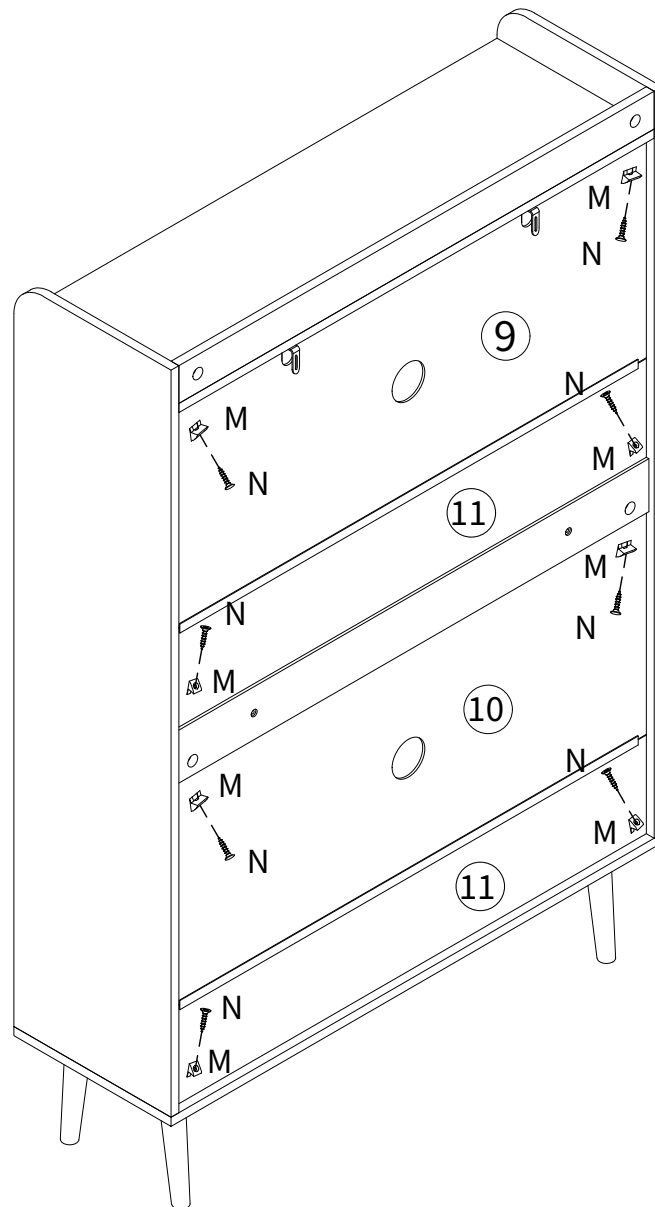

Step 14

Use screw (O) to lock part (A) and (B) to panel ⑬ and ⑭. Positions are as shown below.

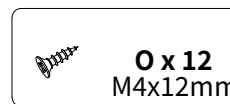
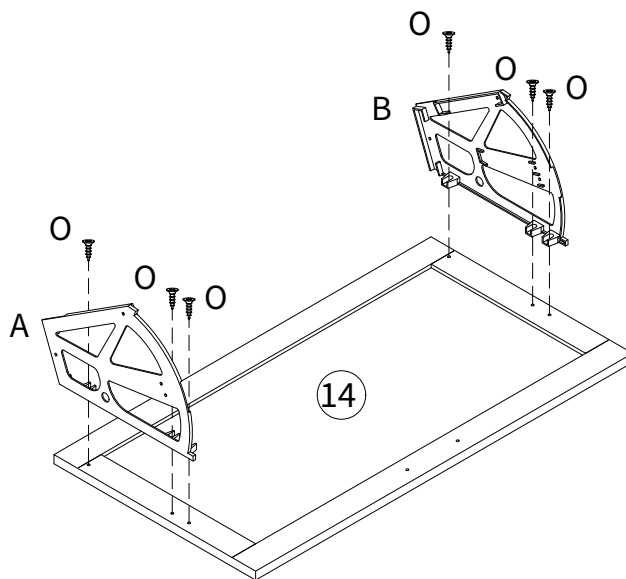
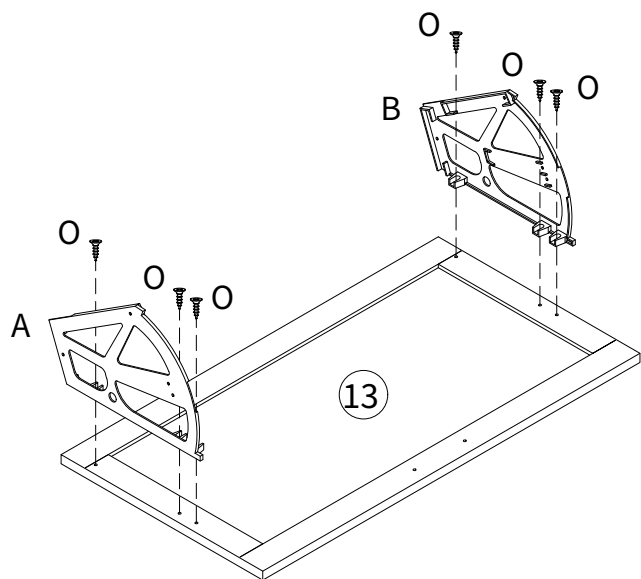

Step 15

Use screw (O) to lock panel ⑯ to part (A) and (B). Positions are as shown below.

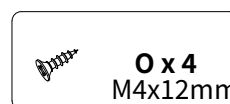
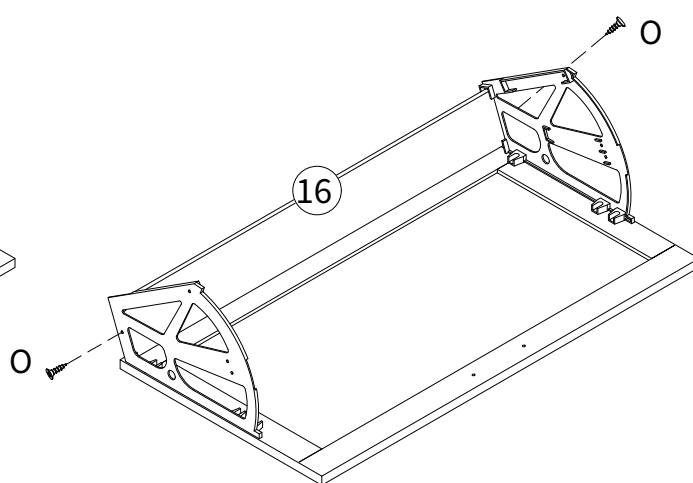
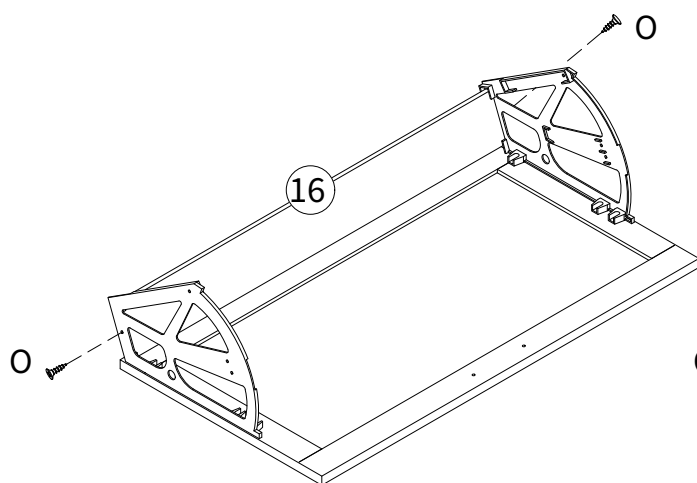

Step 16

Use screw (O) to lock panel 15 to part (A) and (B). Positions are as shown below.

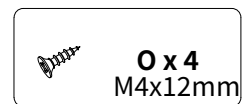
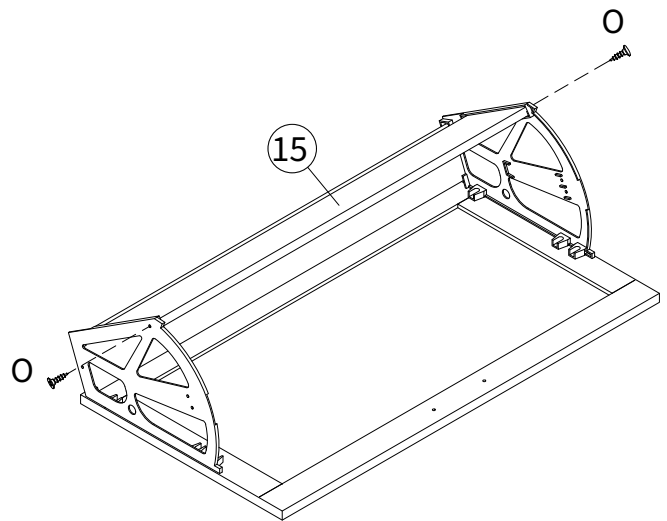
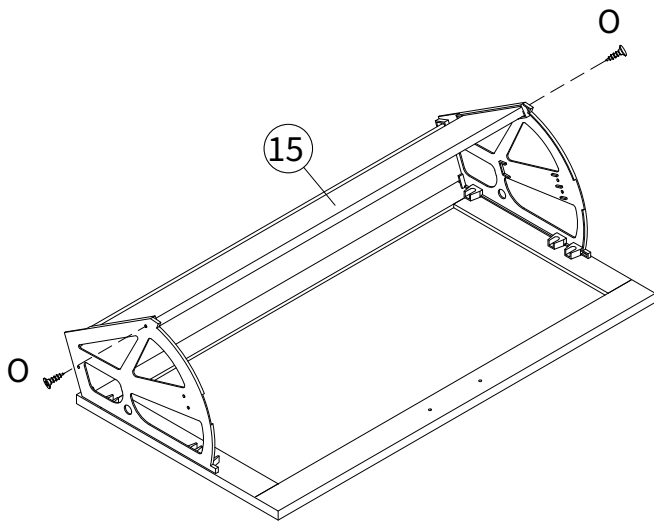

Step 17

Lock handle (P) with bolt (Q). Positions are as shown below.

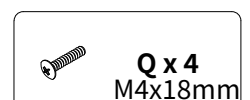
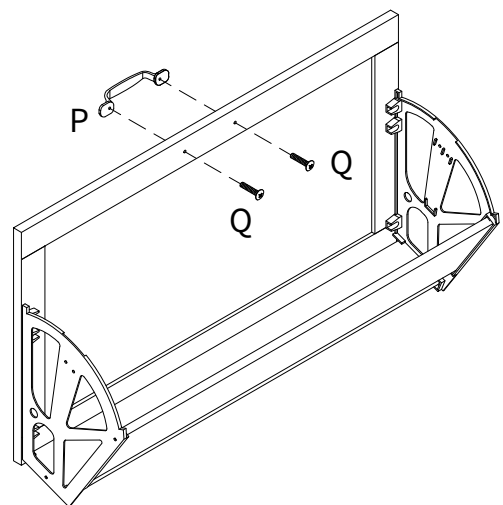
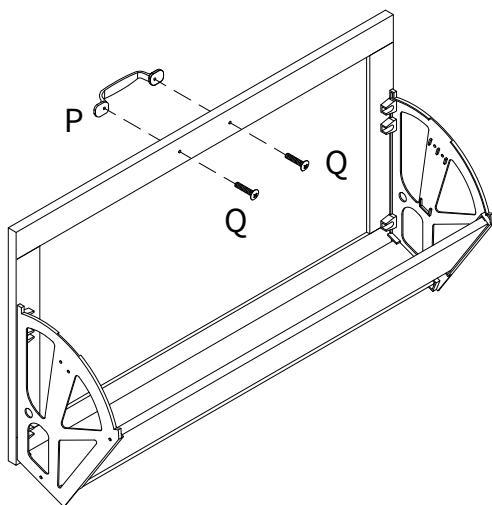

Step 18

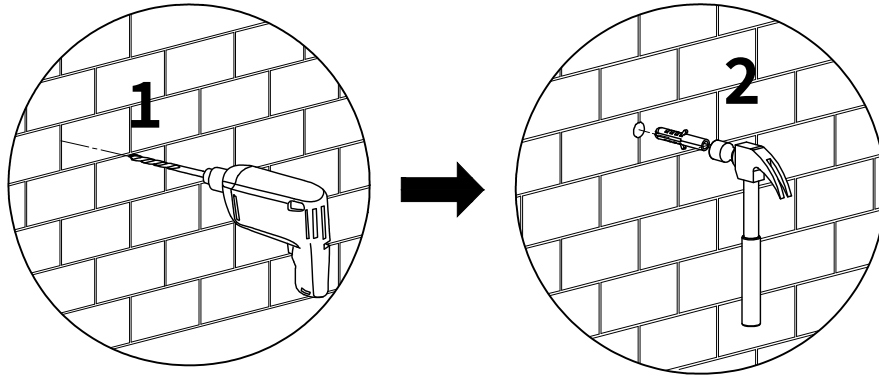

Drill two holes on the wall and fix part (R) to the holes by using screw (H) through part (J). Positions are as shown below.

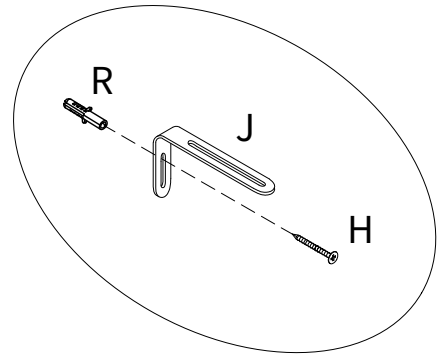
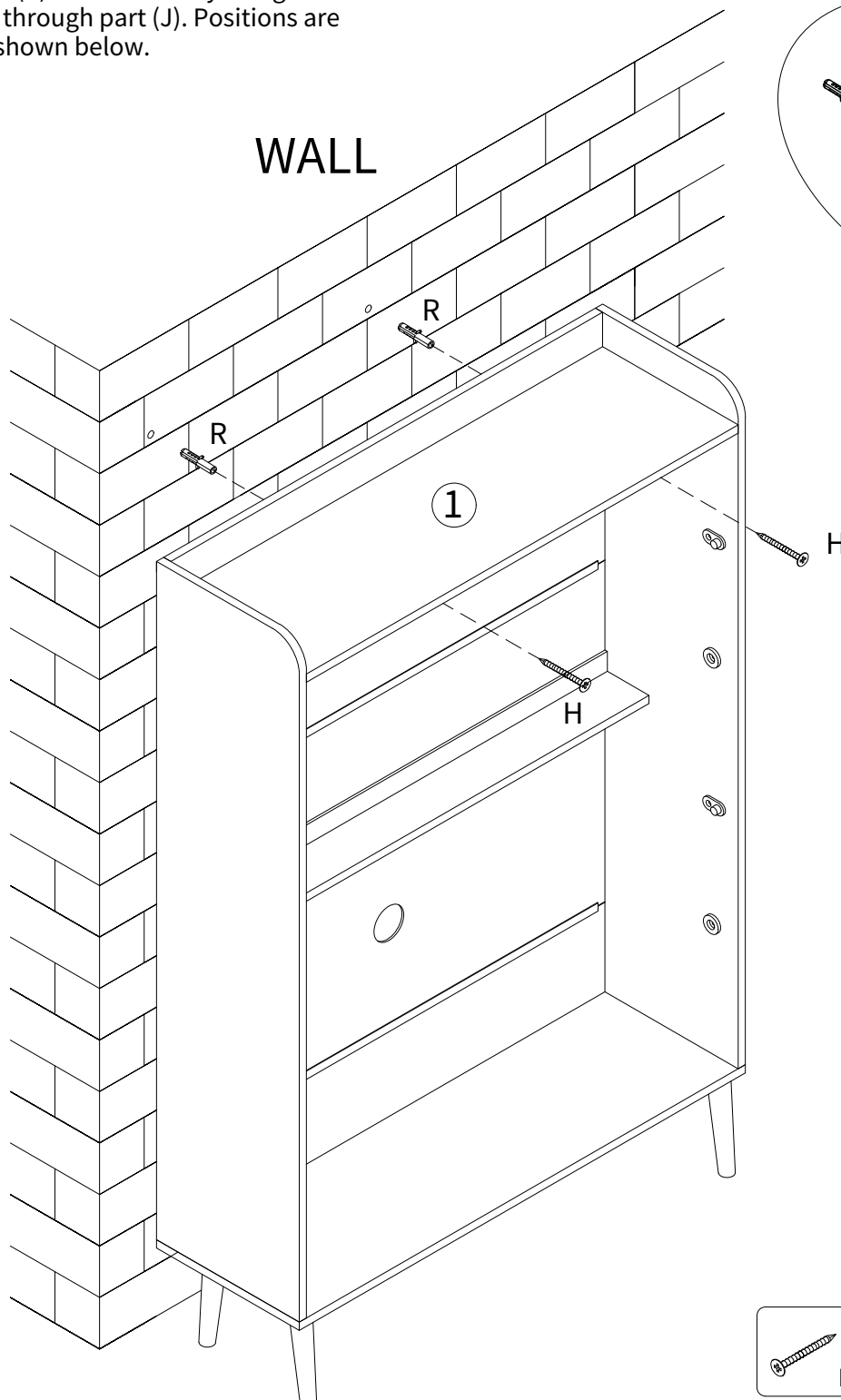

Step 19

Use screw (S) to lock part (C) to panel ② and ③. Positions are as shown below.

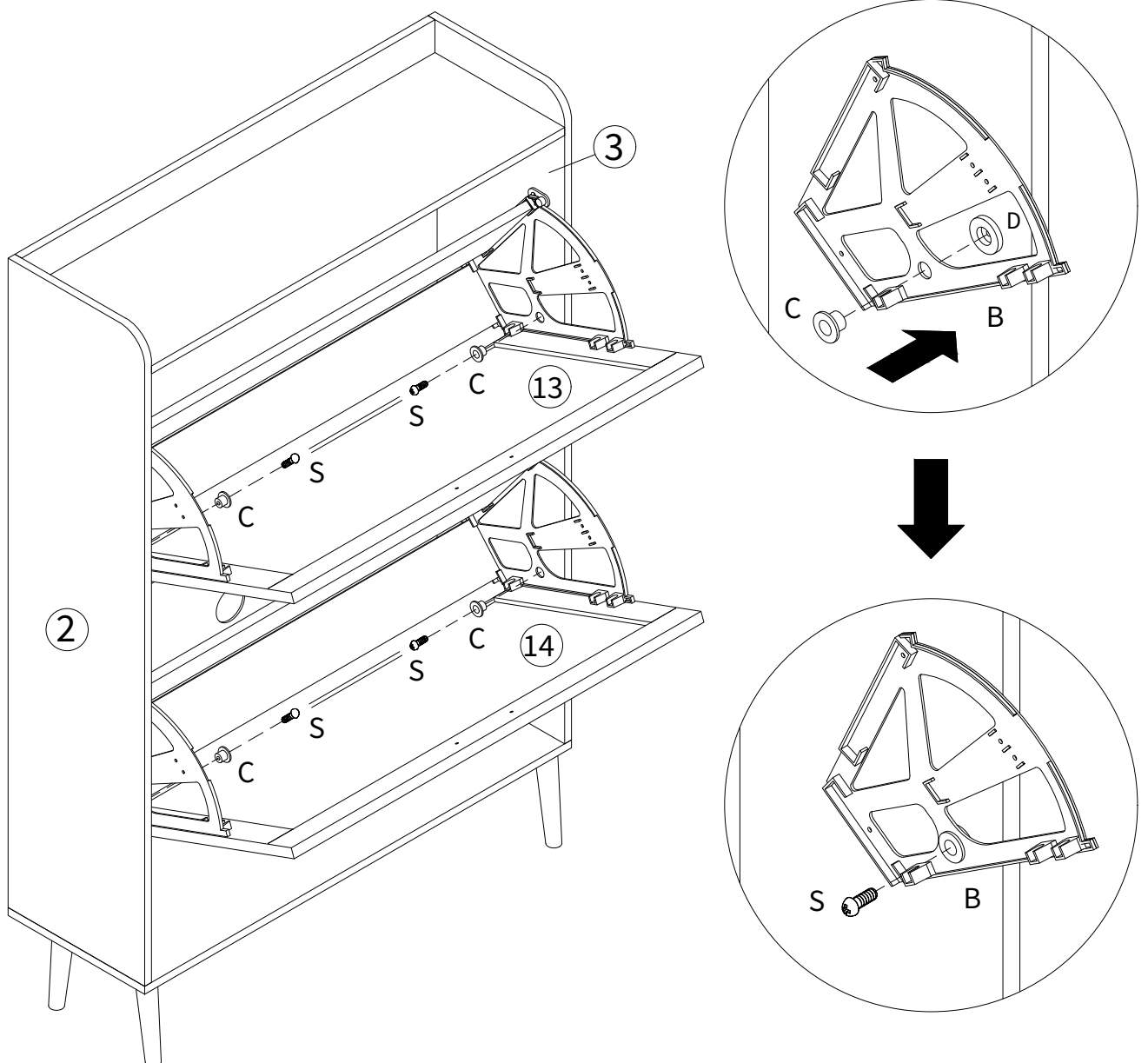

Step 20

Use screw (O) to lock panel ⑮. Positions are as shown below.

