

ADULT ASSEMBLY REQUIRED

KD 3-SHELF STORAGE: 1526308, KD SECTIONAL CUBBY: 1537048

BIRD•IN•HAND

Woodworks, Inc.

Lancaster, Pennsylvania
A member of the School Specialty Family

Product Guide - General Instructions and Information

Customer Service:

P.O. Box 1579, Appleton, WI 54912-1579

Phone: 1-888-388-3224

Customer Care Website:

<https://help.schoolspecialty.com/s/>

Warning:

This product is for children. Supervision is required at all times.

Warning:

Manufacturer is not responsible for changes made to our products by customers.

Cleaning:

Use a mild soap and water solution. Be sure to wipe all water from the wood surface.

Important:

Keep these instructions for future reference.

STEP 1: ASSEMBLE SHELVES TO SIDE PANEL

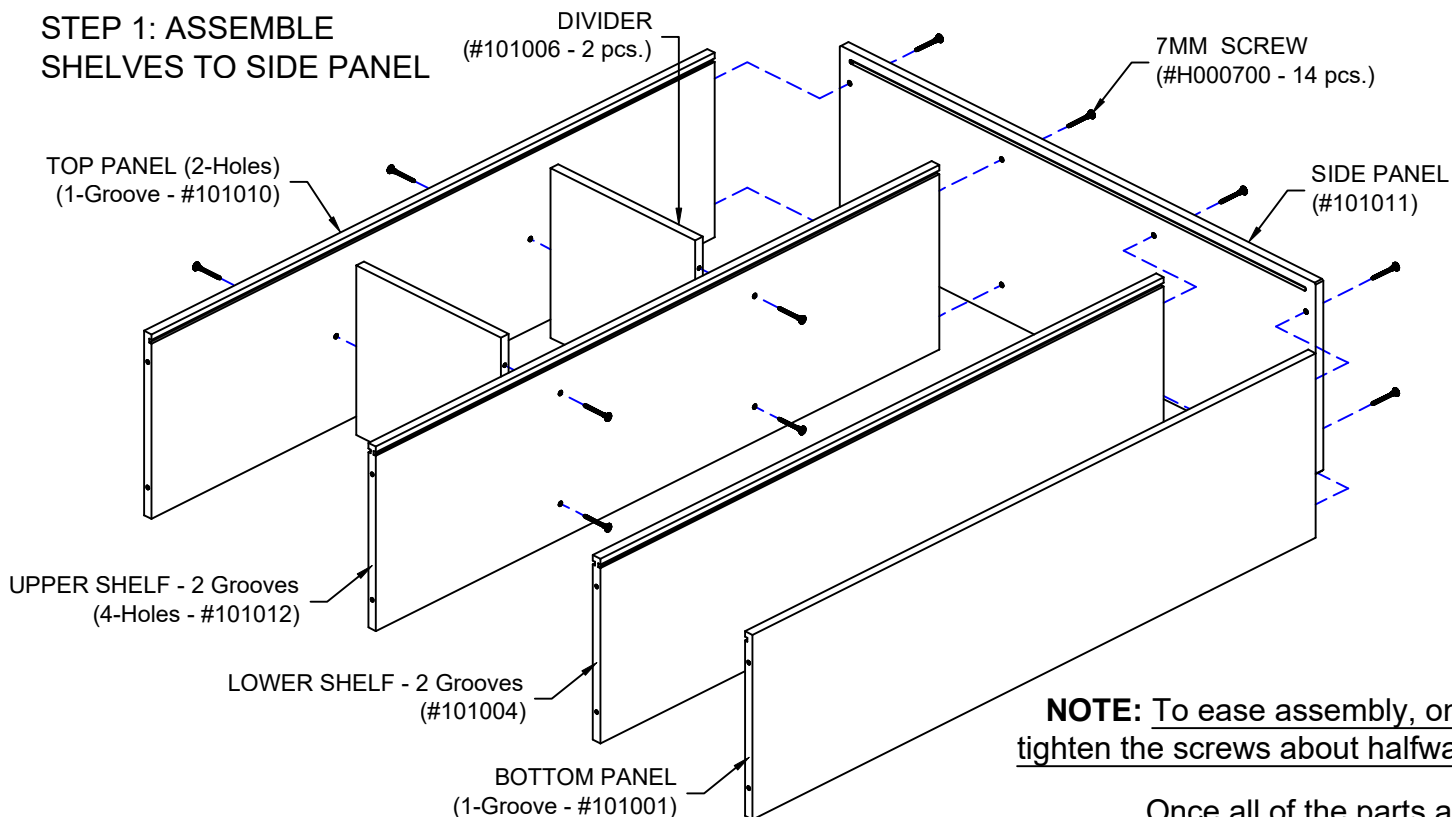

NOTE: To ease assembly, only tighten the screws about halfway!

Once all of the parts are together, then finish tightening the screws using the supplied allen wrench. Do not over-tighten the screws! This can cause the screws to strip out, which will weaken the assembled unit.

STEP 2: INSERT BACK PANELS

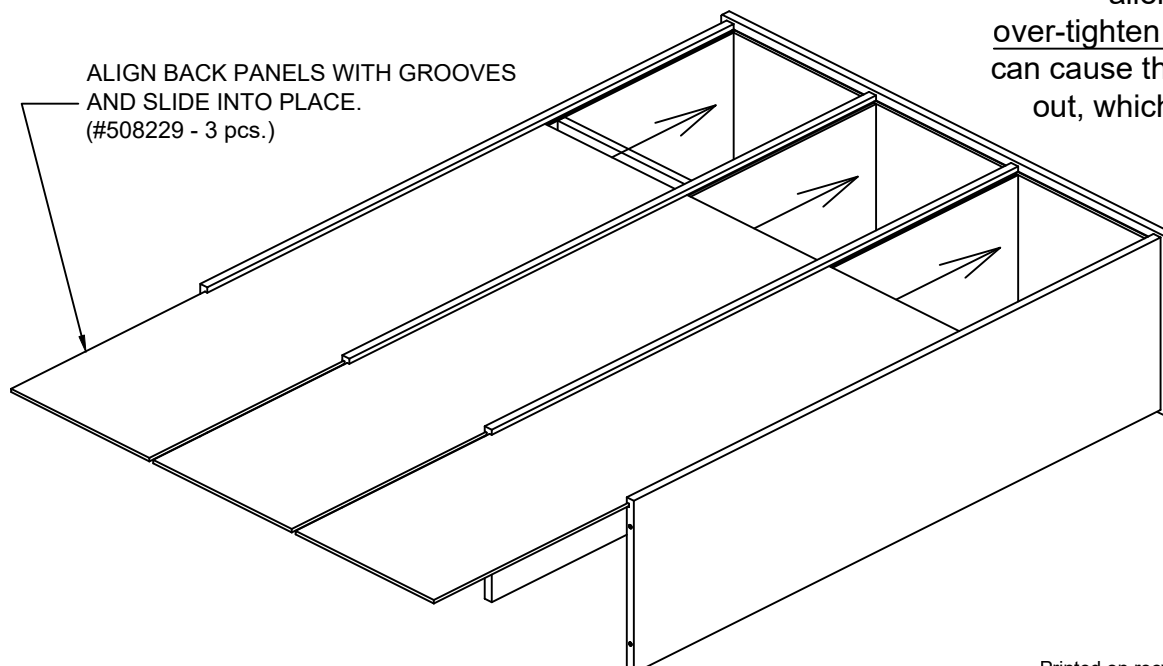

ADULT ASSEMBLY REQUIRED

KD 3-SHELF STORAGE & SECTIONAL STORAGE

BIRD•IN•HAND

Woodworks, Inc.

Lancaster, Pennsylvania
A member of the School Specialty Family

Product Guide - General Instructions and Information

STEP 3: ATTACH REMAINING SIDE PANEL

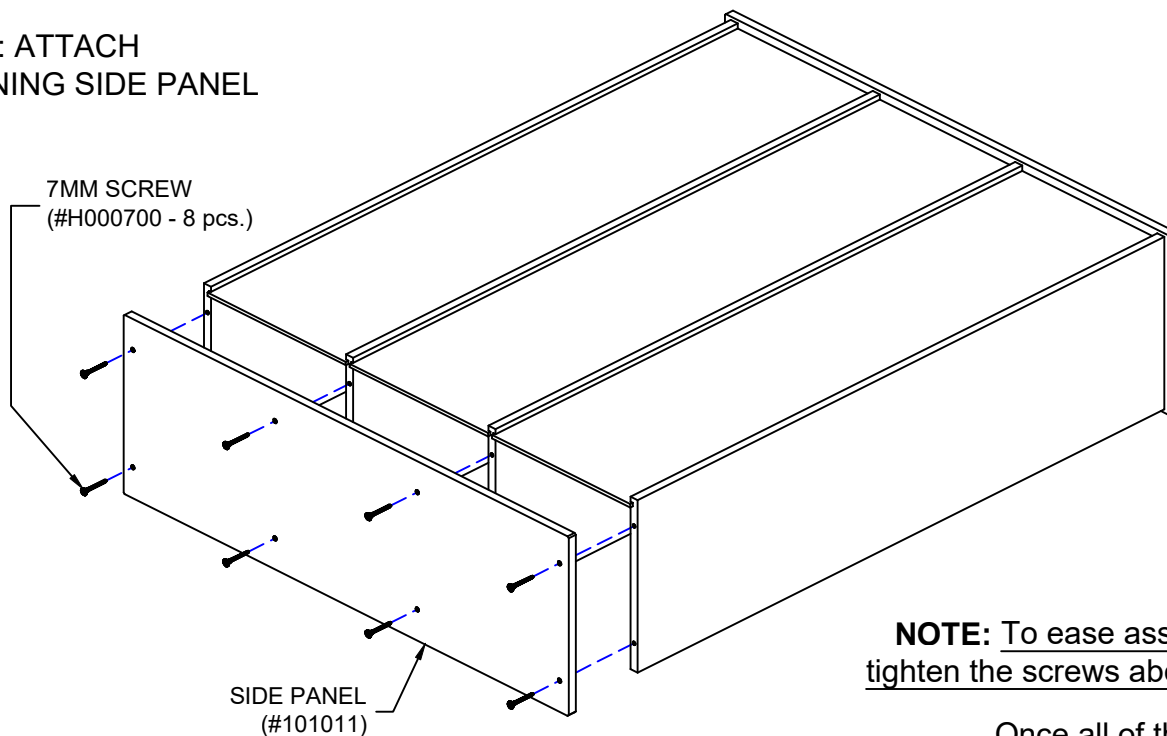

NOTE: To ease assembly, only tighten the screws about halfway!

Once all of the parts are together, then finish tightening the screws using the supplied allen wrench. Do not over-tighten the screws! This can cause the screws to strip out, which will weaken the assembled unit.

STEP 4: ATTACH FEET TO BOTTOM PANEL

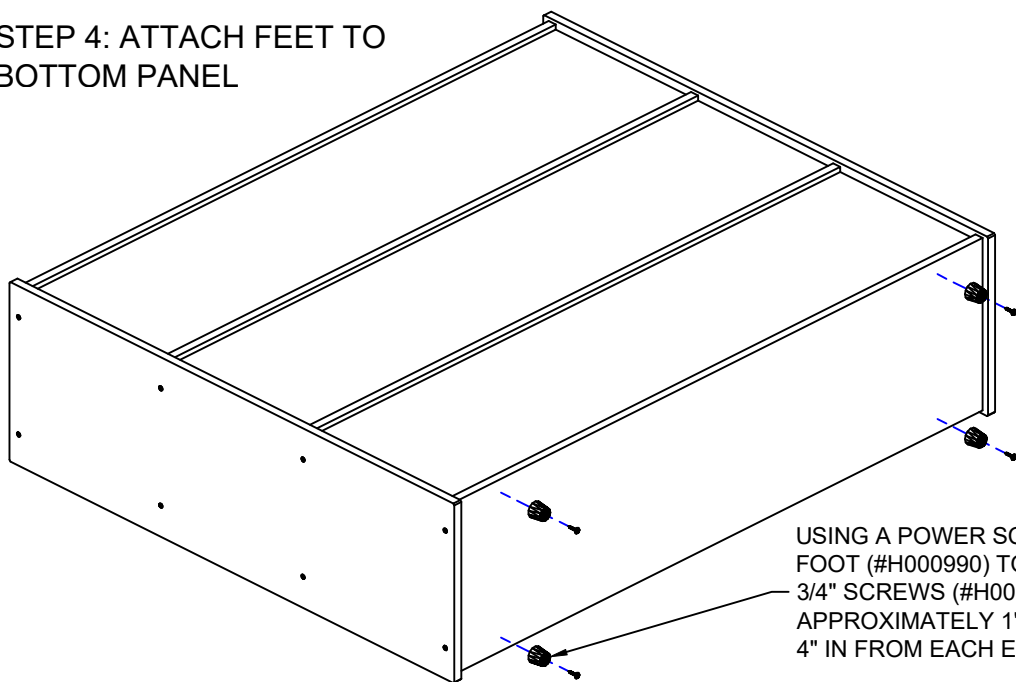

NOTE: If you purchased the 3-Shelf Storage unit, your assembly is complete. If you purchased a Sectional Cubby unit, the instructions are continued on the next page.

ADULT ASSEMBLY REQUIRED

KD 3-SHELF STORAGE & SECTIONAL STORAGE

BIRD•IN•HAND

Woodworks, Inc.

Lancaster, Pennsylvania
A member of the School Specialty Family

Product Guide - General Instructions and Information

STEP 5: ADD CUBBY TRAY INSERTS

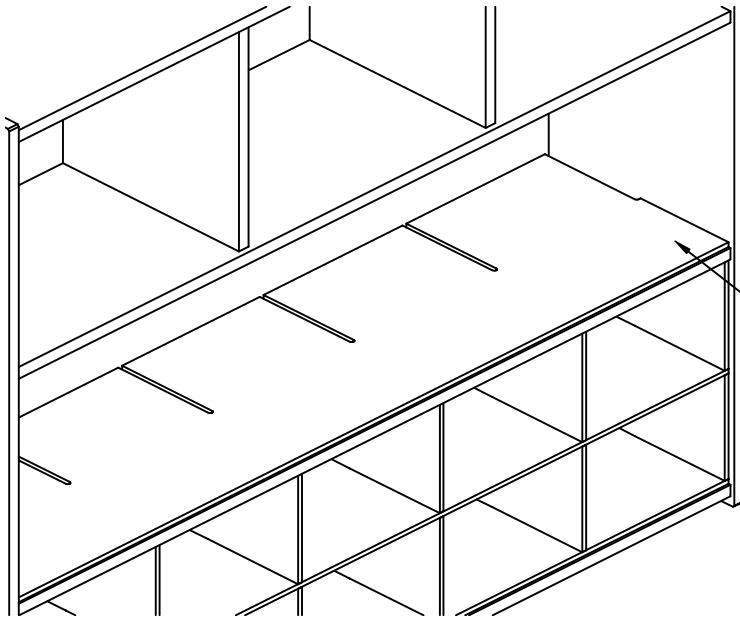

A: LAY ONE CUBBY SHELF (#508236) IN PLACE AS SHOWN WITH SLOTS FACING TOWARDS THE BACK PANEL.

B: PLACE THE CUBBY DIVIDERS (#508237) AS SHOWN SO THAT THE SLOTS ARE FACING FORWARD. START BY INSERTING EACH DIVIDER AT AN ANGLE SO THAT THE BOTTOM TAB FITS INTO THE SLOTS OF THE SHELF, AND THEN TURN THEM UNTIL THEY ARE UPRIGHT.

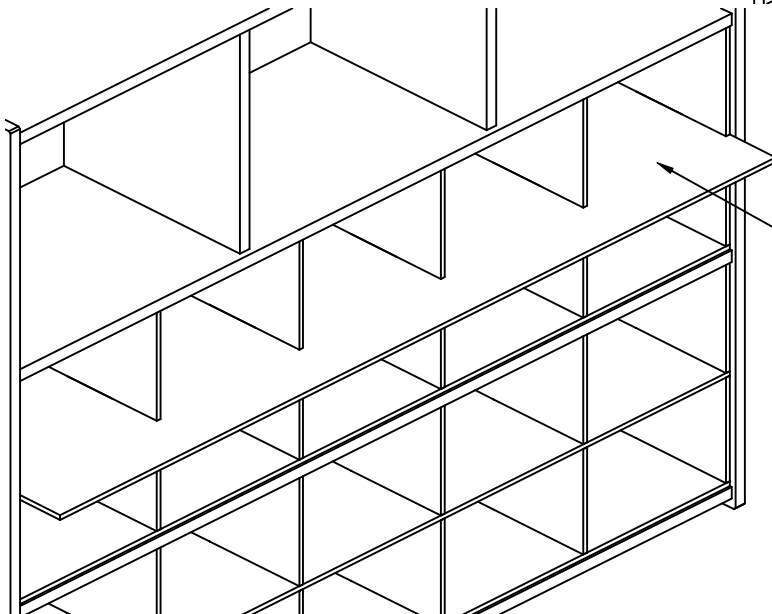
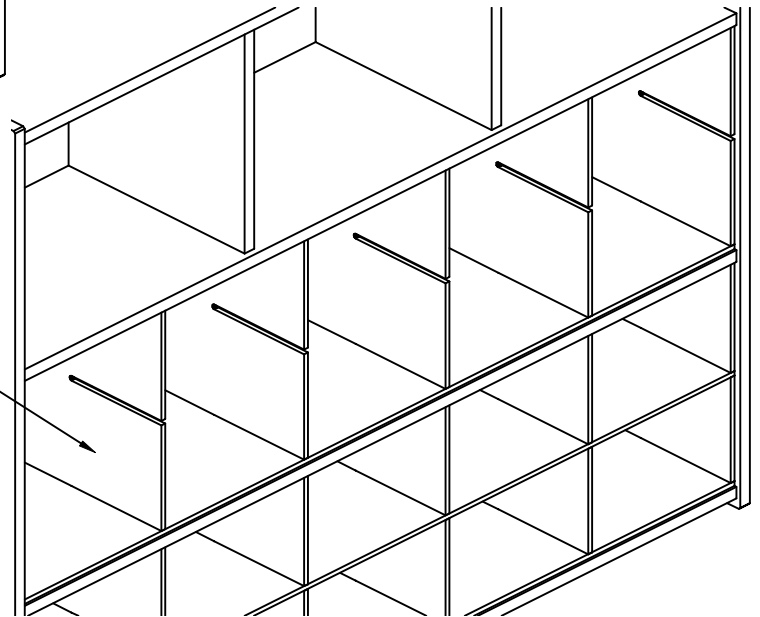

C: SLIDE THE REMAINING SHELF (#508236) IN PLACE TO FINISH BUILDING THE CUBBY. (IT MIGHT BE NECESSARY TO JIGGLE THE SHELF SLIGHTLY TO ALIGN IT WITH THE DIVIDERS.)

ADULT ASSEMBLY REQUIRED

KD 3-SHELF STORAGE & SECTIONAL STORAGE

BIRD•IN•HAND

Woodworks, Inc.

Lancaster, Pennsylvania
A member of the School Specialty Family

Product Guide - General Instructions and Information

STEP 6: ADD END SHELVES

A: INSERT SHELF
SUPPORTS INTO
OPENING
(#508231 - 4 pcs.)

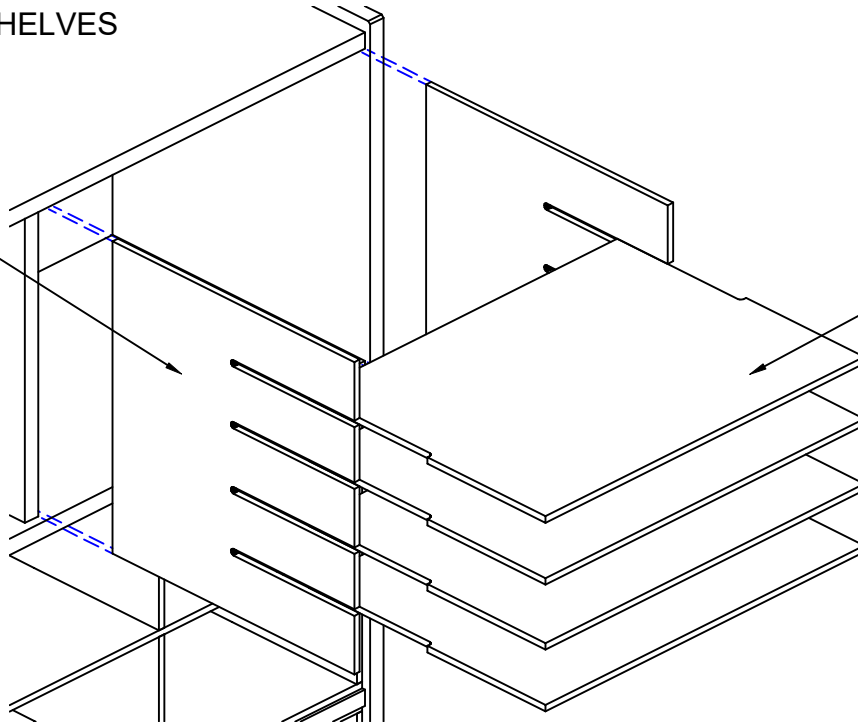

B: SLIDE SHELVES
INTO SUPPORTS
(#508232 - 8 PCS.)

STEP 7: ADD CENTER DIVIDERS

A: INSERT BOTTOM
DIVIDER INTO
OPENING
(#508233)

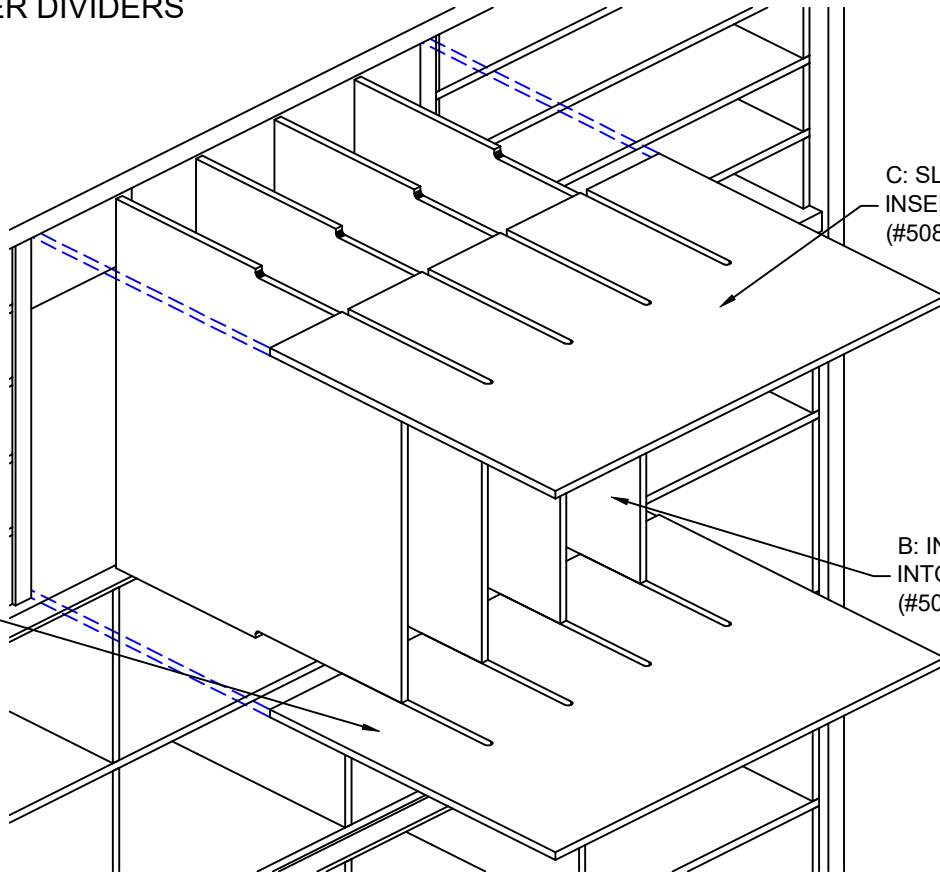

C: SLIDE TOP DIVIDER
INSERT OVER DIVIDERS
(#508233)

B: INSERT DIVIDERS
INTO BOTTOM SUPPORT
(#508234)