

ASSEMBLY INSTRUCTIONS
INSTRUCTIONS DE MONTAGE
INSTRUCCIONES DE ENSAMBLAJE

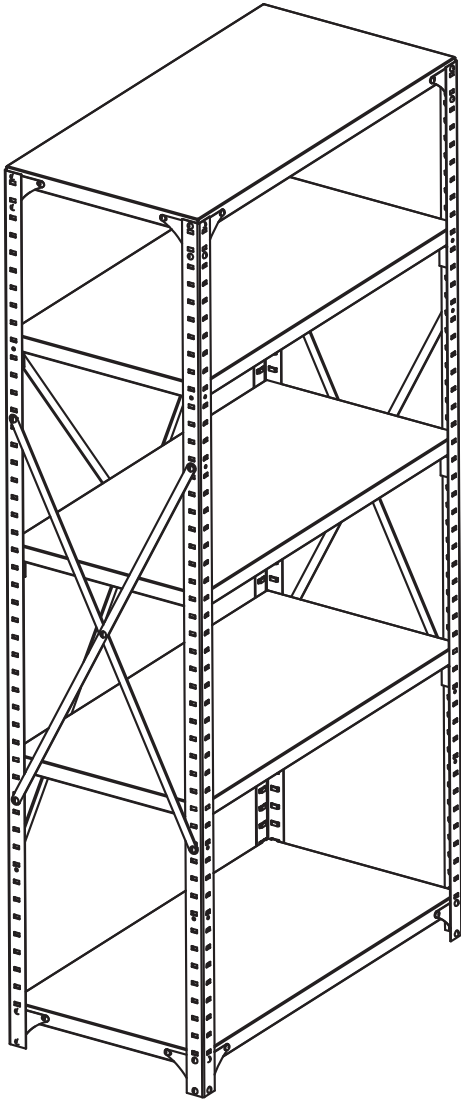

Commercial Shelving

Étagères industrielle
Estantería industrial





**Two people
recommended**
*Deux personnes ont
recommandé*
Dos personas
recomendadas

TOOLS REQUIRED: Screwdriver; Rubber Mallet

PARTS LIST

CODE	DESCRIPTION	QTY	PART NO.
(A)	Post 75" high	4	
(B)	Steel Shelf Top and Bottom 12" x 36" 18" x 36" 24" x 36"	2	
(C)	Steel Shelf center 12" x 36" 18" x 36" 24" x 36"	3	
(D)	Long Brace	2	
(E)	Short Brace	4	

HARDWARE PACK

F  Corner Clip Qty: 12	G  Screw Qty: 63	H  Nut Qty: 63	I  Plastic Foot Qty: 4	J  Corner Plate Qty: 16
---	---	---	---	--

§ Note: When corresponding about the product don't forget to mention the shelf size.





To ensure that you have enough screws and nuts, extras have been included.

OUTILS REQUIS : Tournevis; Maillet du caoutchouc

LISTE DES PIÈCES

CODE	DESCRIPTION	QTY	PART NO.
(A)	Poste 75" de haut	4	
(B)	Étagère en acier haut et en bas 12" x 36" 18" x 36" 24" x 36"	2	
(C)	Étagère en acier Centre 12" x 36" 18" x 36" 24" x 36"	3	
(D)	longue étréssillon	2	
(E)	Court étréssillon	4	

PAQUET MATERIAL

F  Coin équerre Qté: 12	G  Vis Qté: 63	H  Écrou Qté: 63	I  Plastique pied Qté: 4	J  Coin plaque Qté: 16
--	---	---	---	---

§ Noter: Lorsque vous correspondez au sujet du produit, n'oubliez pas de mentionner la taille du Étagère.





Pour veiller à ce que vous avez suffisamment de vis et les écrous, les suppléments ont été inclus.

HERRAMIENTAS REQUERIDAS: Destornillador ;Mazo de caucho

LISTA DE PIEZAS

CODE	DESCRIPTION	QTY	PART NO.
(A)	Post 75" de alto	4	
(B)	Estante de acero parte superior e inferior 12" x 36" 18" x 36" 24" x 36"	2	
(C)	Estante de acero Centro 12" x 36" 18" x 36" 24" x 36"	3	
(D)	Puntal largo	2	
(E)	Corto puntal	4	





PAQUETE MATERIAL

F  Soporte de esquina Cant: 12	G  Tornillo Cant: 63	H  Tuerca Cant: 63	I  Pie de plástico Cant: 4	J  Esquina placa Cant: 16
---	---	---	---	--

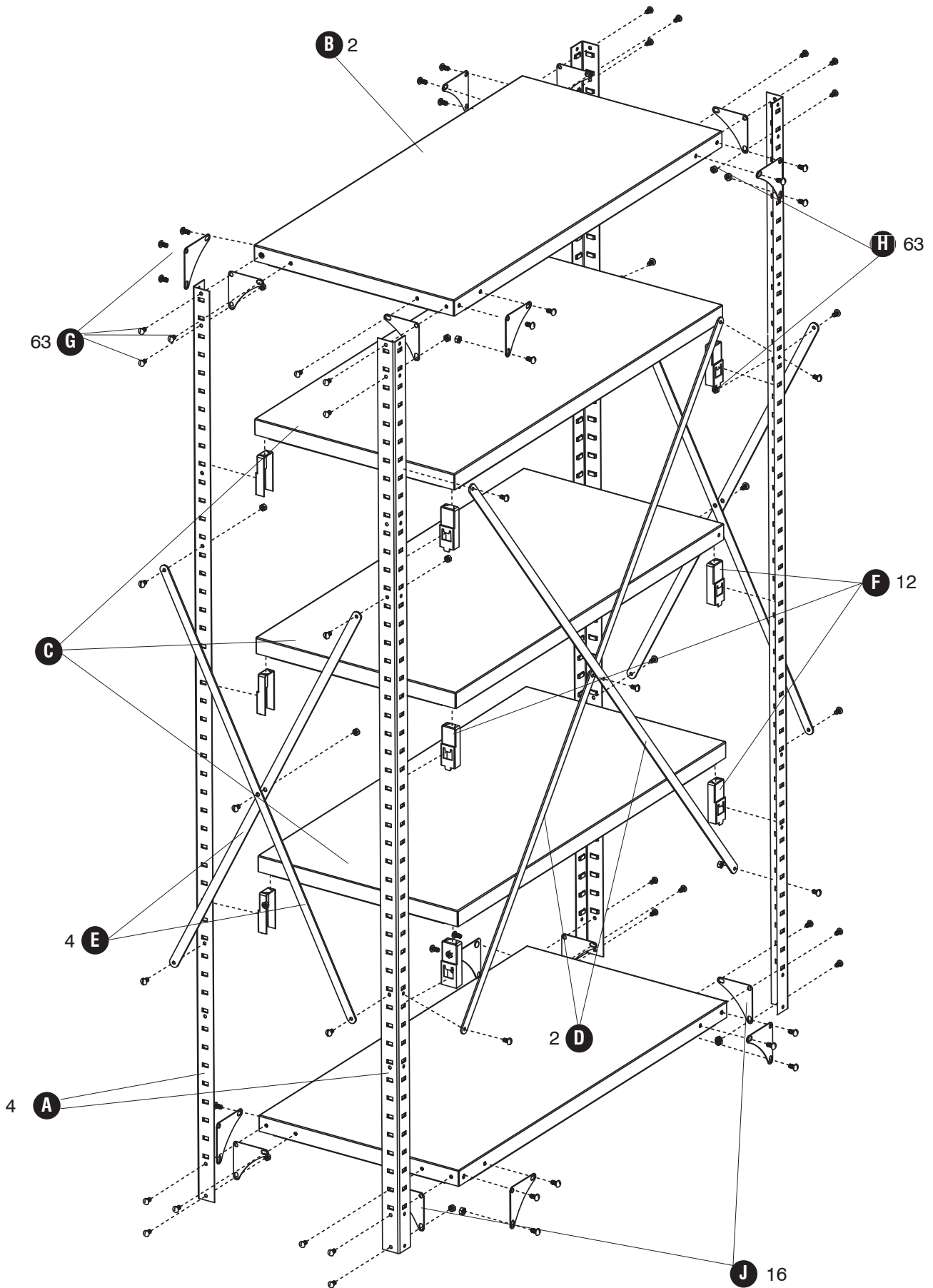
§ Nota: Cuando correspondientes sobre el producto no se olvide de mencionar el tamaño de la Estante.

Para asegurarse de que tiene suficiente tornillos y tuercas, los extras se han incluido.



- 1 **G**  24 **H**  24 **I**  4 **J**  8

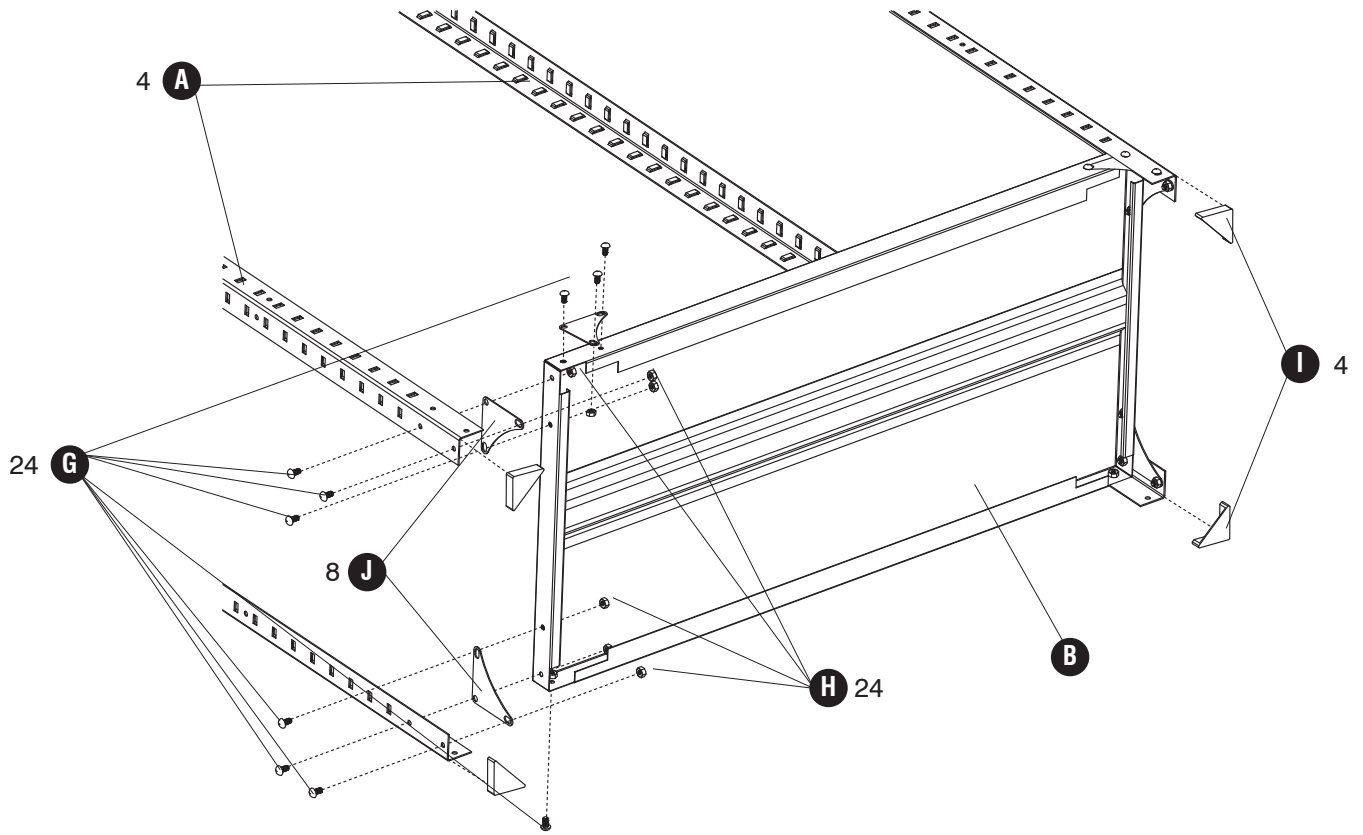

- 2 **G**  24 **H**  24 **J**  8

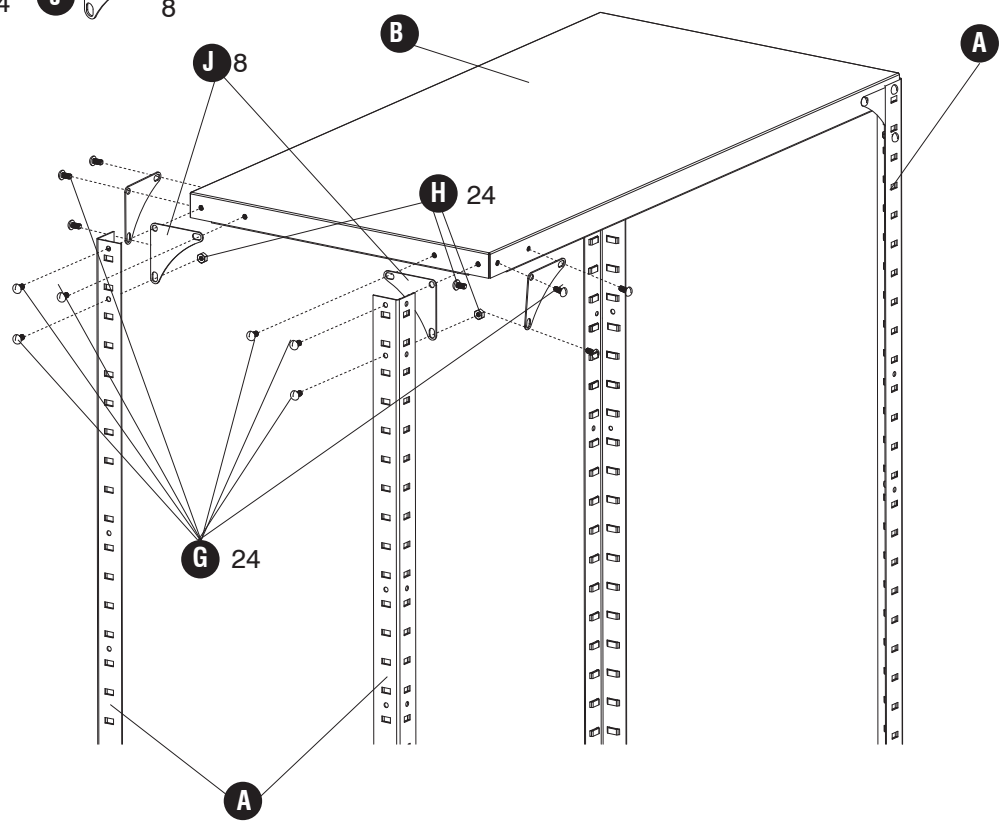

3 G 15 H 15

NOTE: Refer to the chart below for placement of braces on the different size shelving units.

NOTER: Consultez le tableau ci-dessous pour le placement des renforts sur la différents taille des étagères.

NOTA: Consulte la tabla de abajo para la colocación de soporte para el tamaño de diferentes estanterías

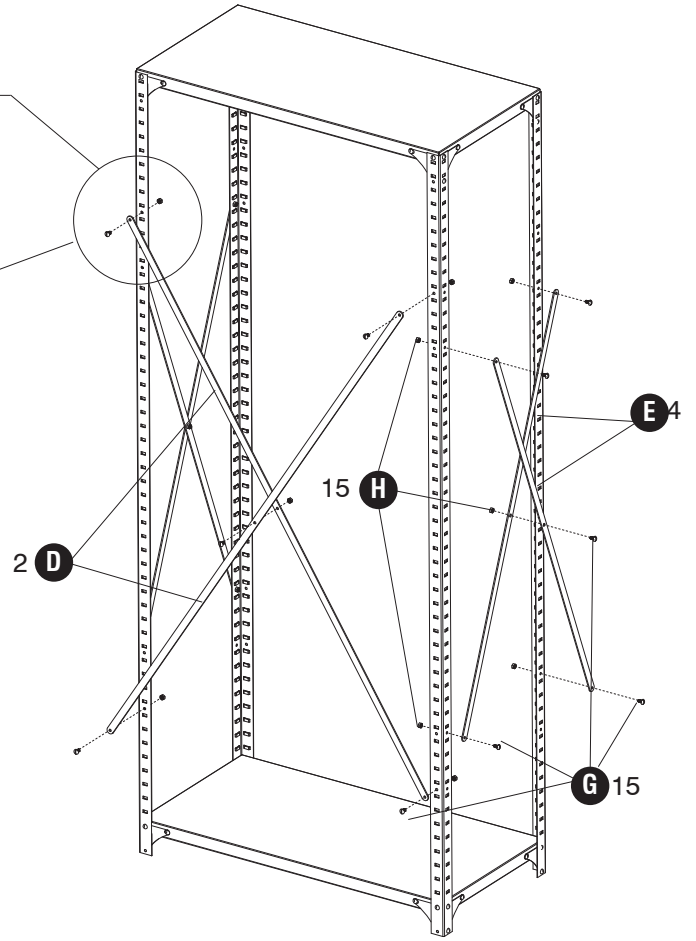
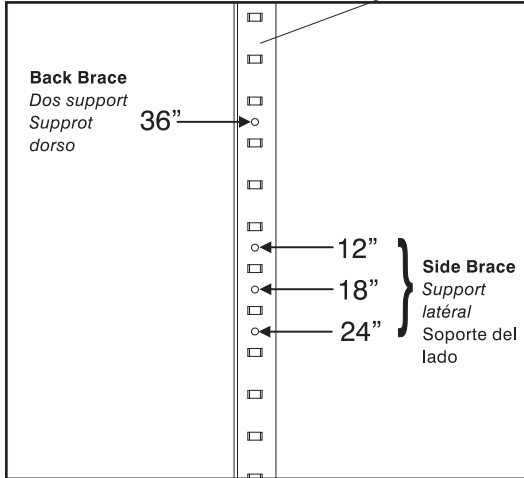

4

