

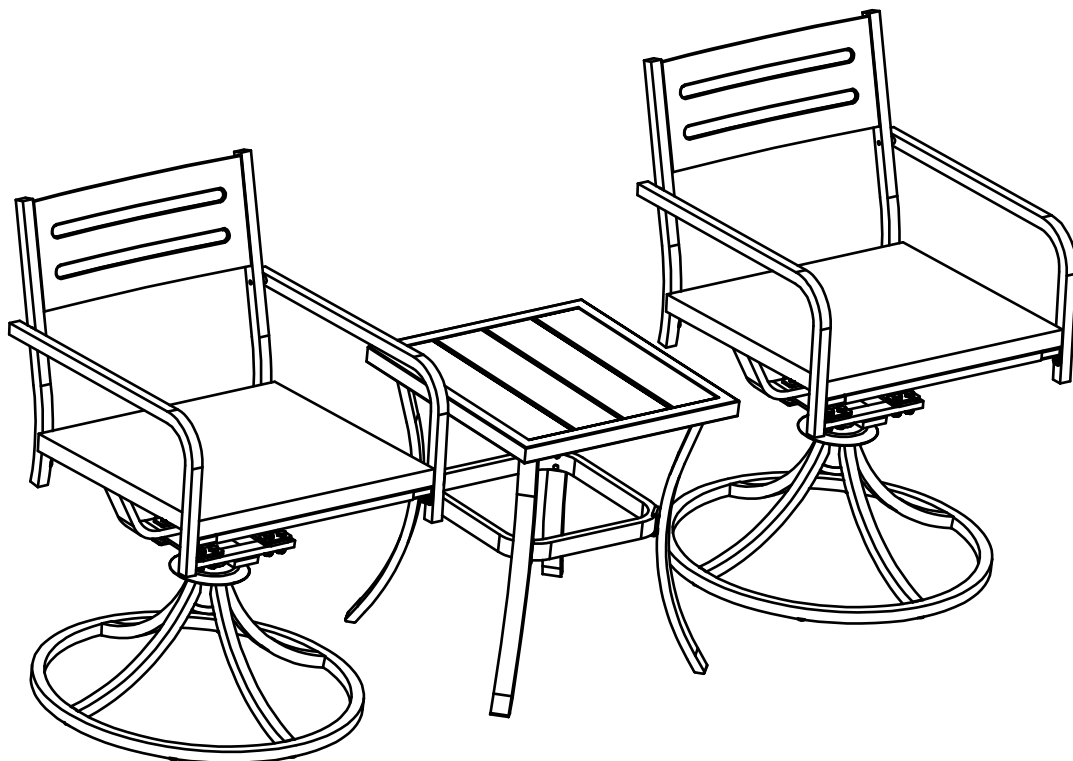

Outdoor Swivel Dining Chairs with Small Table

ASSEMBLY MANUAL



MODEL#: LCCF0490A-ST

Missing part? Damaged? Contact us via email at

service@domioutdoorliving.com

www.domioutdoorliving.com

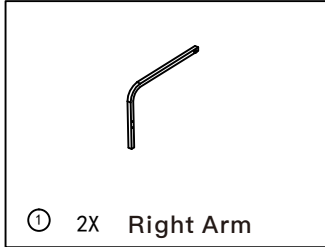

① 2X Right Arm

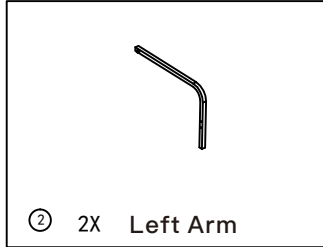

② 2X Left Arm

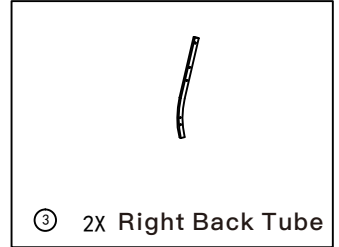

③ 2X Right Back Tube

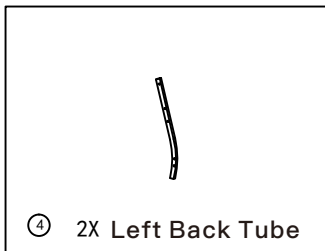

④ 2X Left Back Tube

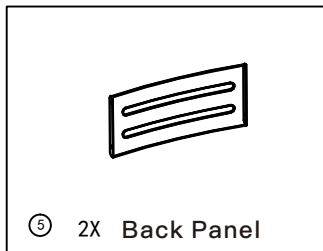

⑤ 2X Back Panel

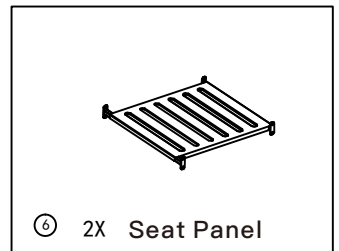

⑥ 2X Seat Panel

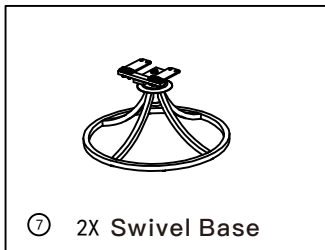

⑦ 2X Swivel Base

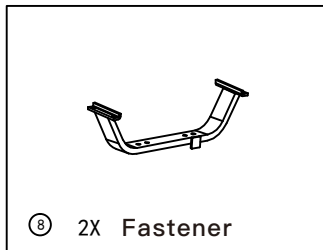

⑧ 2X Fastener

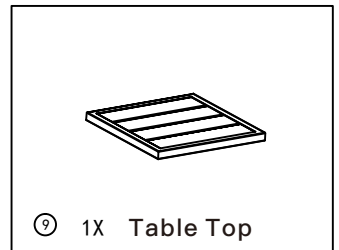

⑨ 1X Table Top



⑩ 1X Leg Brace

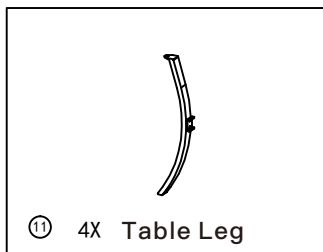

⑪ 4X Table Leg

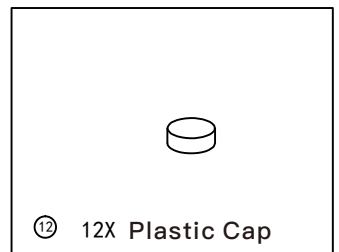

⑫ 12X Plastic Cap

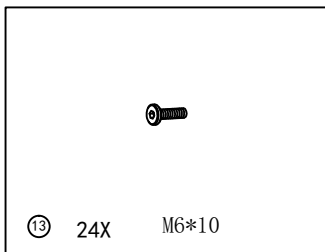

⑬ 24X M6*10

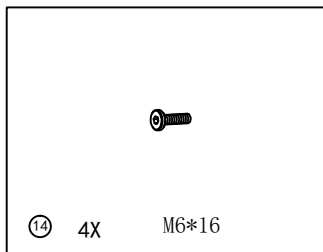

⑭ 4X M6*16

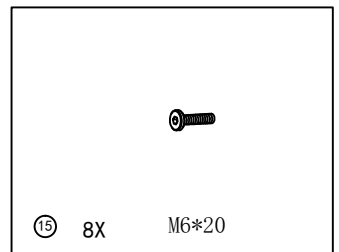

⑮ 8X M6*20

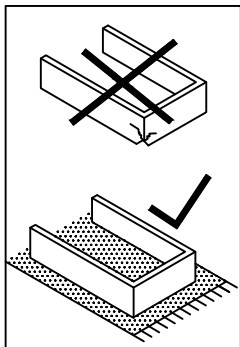

1

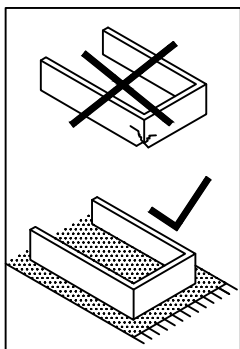
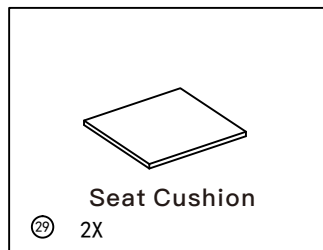
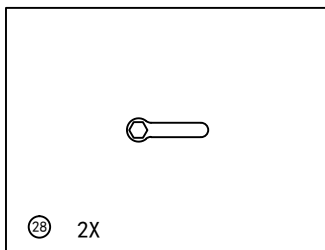
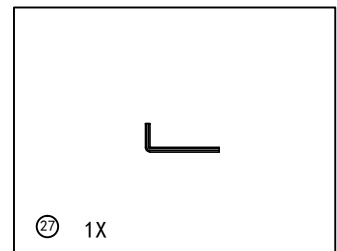
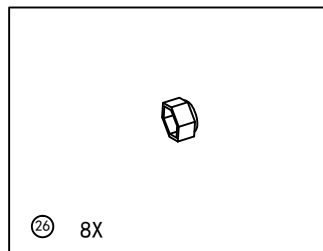
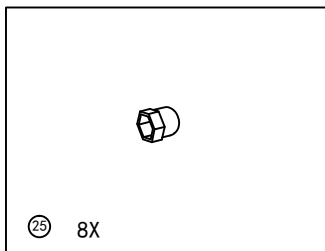
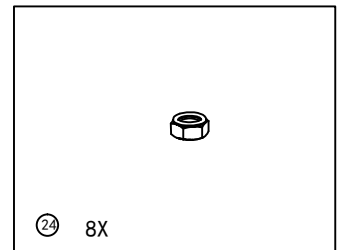
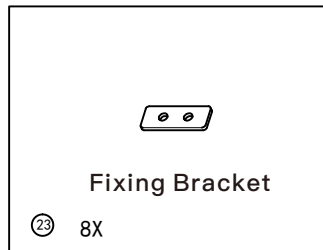
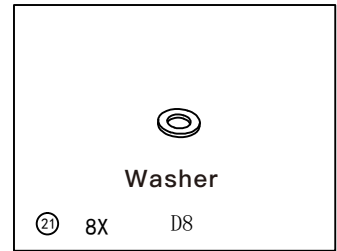
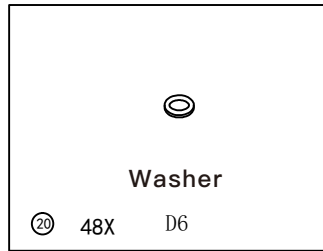
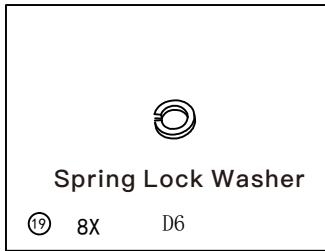
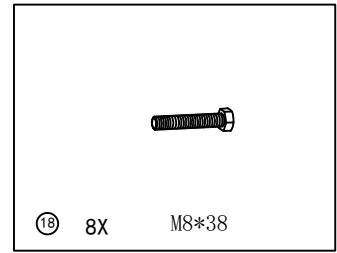
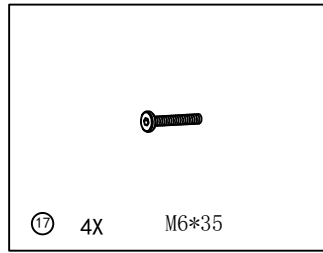
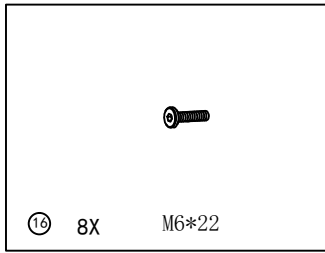





2



READ & SAVE BELOW INSTRUCTIONS BEFORE ASSEMBLY





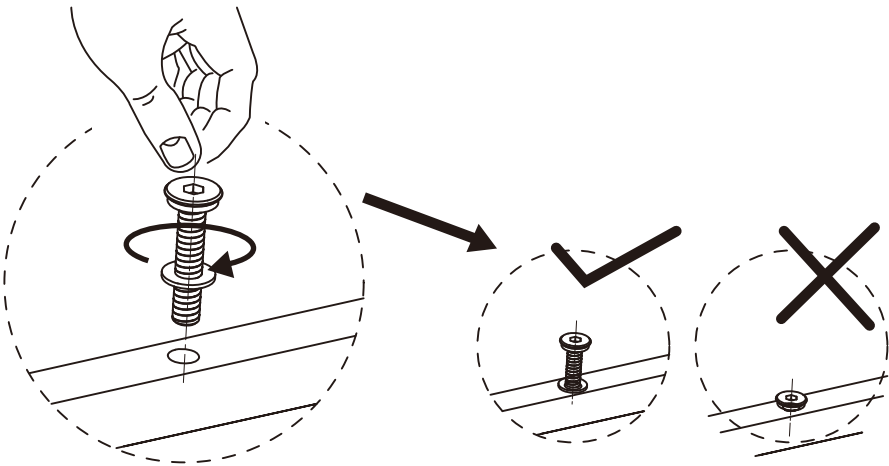
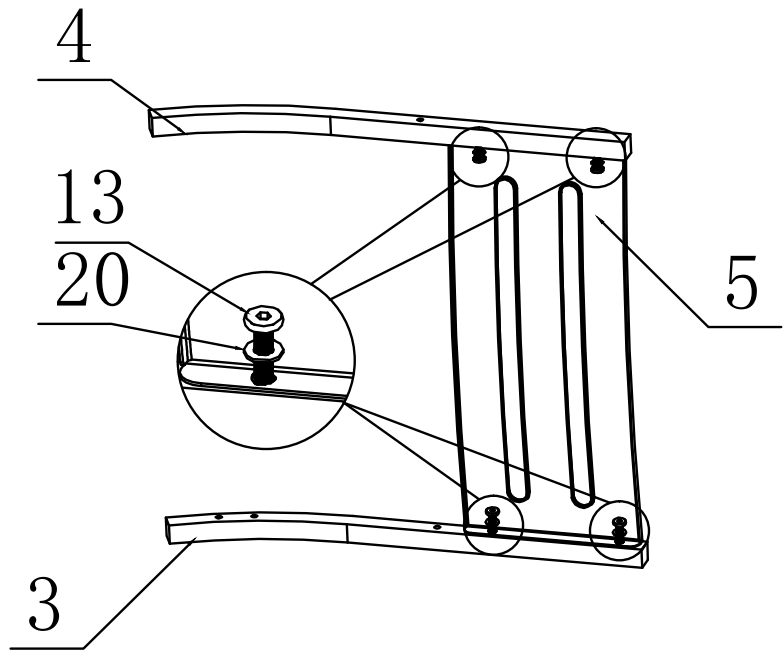

1. PLEASE SEPARATE AND IDENTIFY ALL PARTS, MAKING SURE THAT YOU HAVE ALL OF THE PARTS LISTED.
2. TO AVOID ANY SCRATCH DURING ASSEMBLY, PLEASE ASSEMBLE ON A SOFT MAT OR SIMILAR.
3. PLEASE ASSEMBLE STEP BY STEP AND FOLLOW THE INSTRUCTIONS.
4. WASHERS MUST BE USED.
5. WHILE EACH SCREW AND NUT IS PROPERLY FASTENED, DO NOT OVER FASTEN IT.
6. DO NOT COMPLETELY FASTEN EACH SCREW AND NUT UNTIL ALL THE SCREWS ARE PROPERLY FIXED.

③	/	1X
④	\	1X
⑤		1X
⑬		4X M6*10
⑳		4X
㉗		1X



Attach the Left Back Tube #4 & Right Back Tube #3 to the Back Panel #5 by securing with 4 M6*10 Bolts #13 and Washers #20.



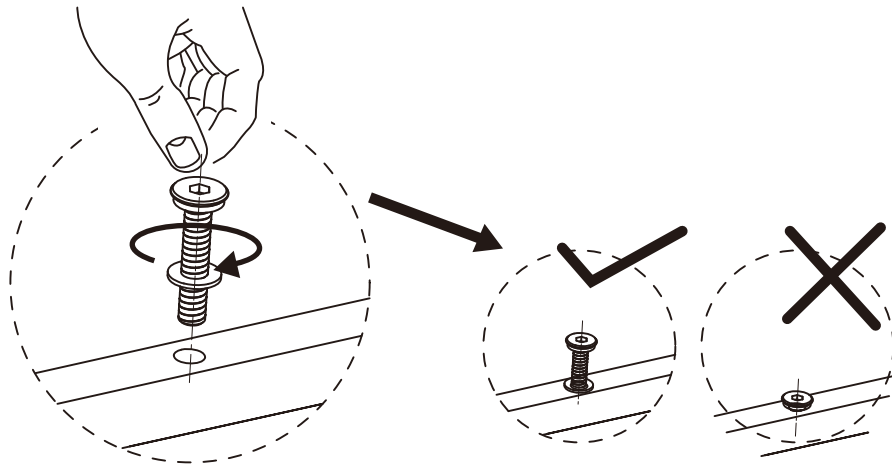
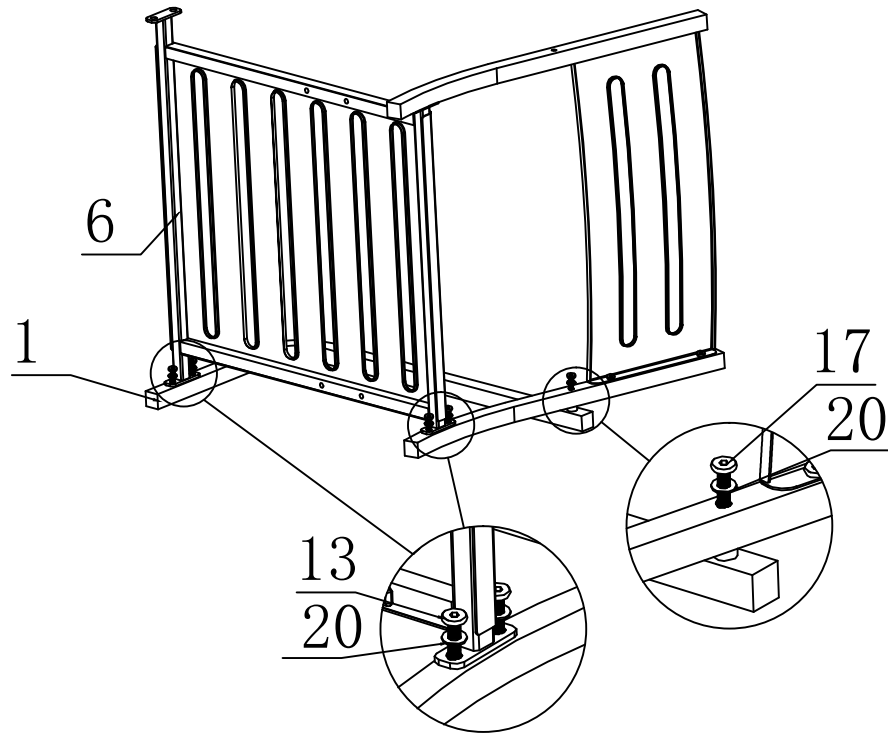

NOTE:DO NOT TIGHTEN THE BOLTS COMPLETELY.

- ① 1X 
- ⑥ 1X 
- ⑬ 4X M6*10 
- ⑰ 1X M6*35 
- ⑳ 5X 
- ㉗ 1X 



Attach the Right Arm #1 to the Right Back Tube by securing with 1 M6*35 Bolt #17 and Washer #20; Attach the Seat Panel #6 to the Right Back Tube by securing with 2 M6*10 Bolts #13 and Washers #20; Attach the Seat Panel #6 to the Right Arm #1 by securing with 2 M6*10 Bolts #13 and Washers #20.

NOTE:DO NOT TIGHTEN THE BOLTS COMPLETELY.

- ② 1X 
- ⑬ 4X M6*10 
- ⑰ 1X M6*35 
- ⑳ 5X 
- ㉓ 1X 

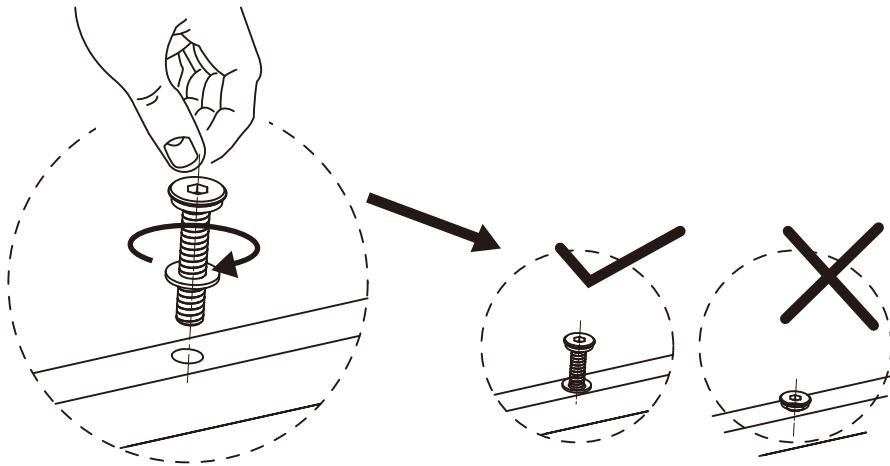
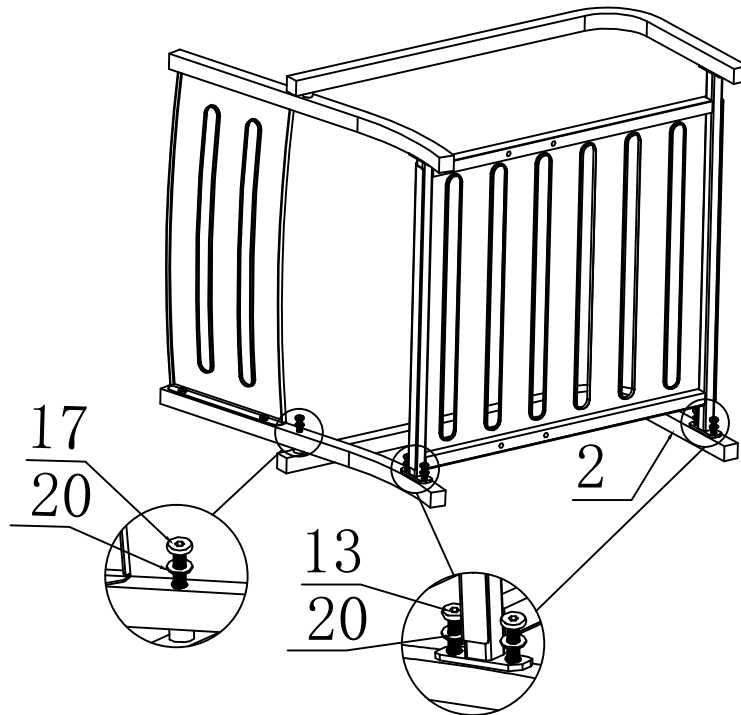

Attach the Left Arm #2 to the Left Back Tube by securing with 1 M6*35 Bolt #17 and Washer #20; Attach the Seat Panel #6 to the Left Back Tube by securing with 2 M6*10 Bolts #13 and Washers #20; Attach the Seat Panel #6 to the Left Arm #2 by securing with 2 M6*10 Bolts #13 and Washers #20.

NOTE:DO NOT TIGHTEN THE BOLTS COMPLETELY.

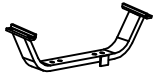

⑧ 1X



⑮ 4X M6*20



⑰ 4X



⑳ 4X





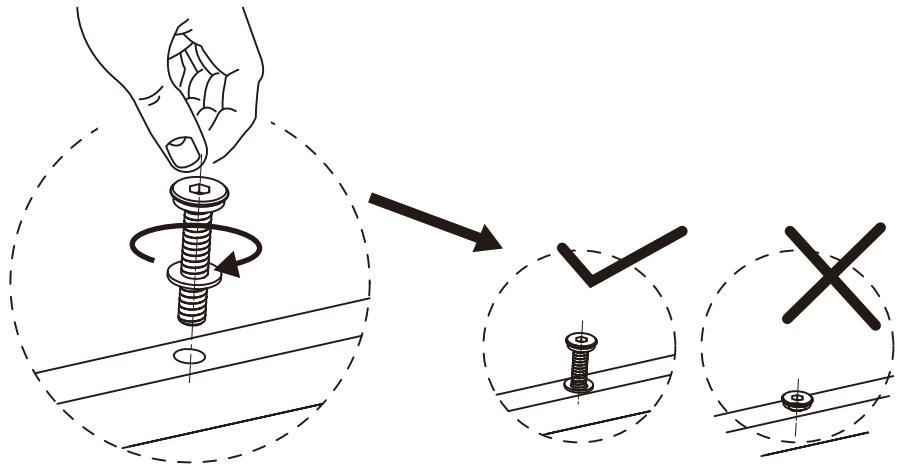
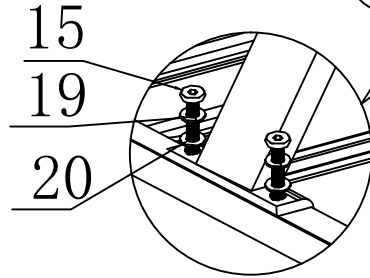
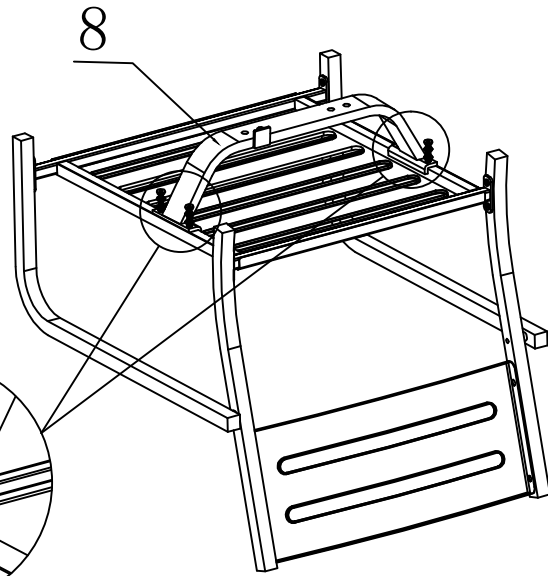





㉗ 1X



Use 4 M6 x 20 Bolts #15, 4 Spring Lock Washers #19 and 4 Washers #20 to secure the Fastener #8 to the Seat Panel.

(Spring Lock Washer #19 should be placed between Bolt #15 and the Washer #20.)

NOTE:DO NOT TIGHTEN THE BOLTS COMPLETELY.

- ⑦ 1X 
- ⑱ 4X M8*38 
- ⑳ 4X 
- ㉑ 4X 
- ㉒ 4X 
- ㉓ 4X 
- ㉔ 4X 
- ㉕ 2X 

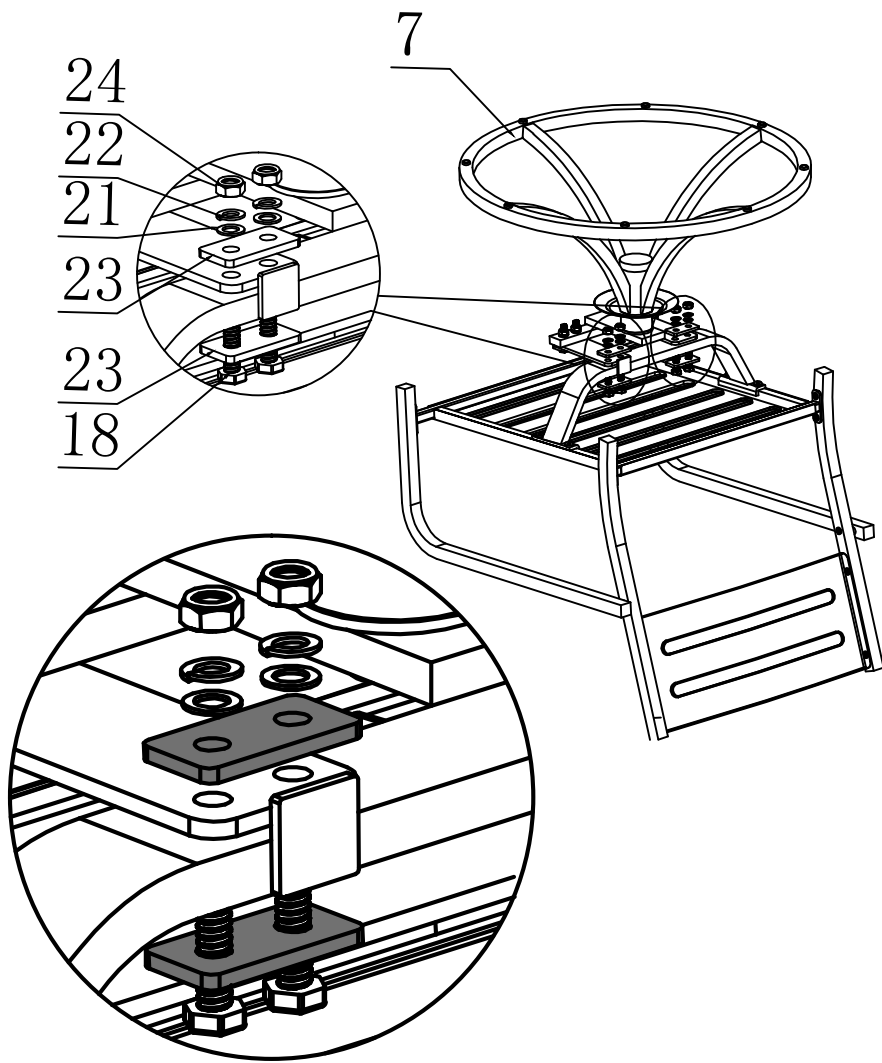

Step 1: Place the Base #7 on the Fastener #8;
 Step 2: Use 2 Fixing Brackets #23, 2 Washers #21 ,
 2 Spring Lock Washers #22 and 2 Nuts #24 to
 secure the Base #7 to the Fastener #8.
 (Please be aware of the installation position
 of the Brackets and Washers)
 Repeat Step 2 to assemble another side.

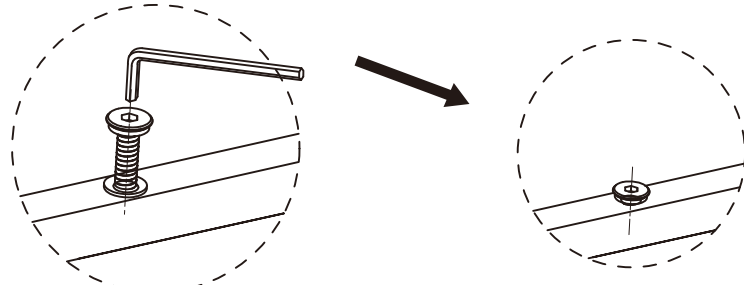

Tighten all the Bolts into Place.



25 4X



26 4X

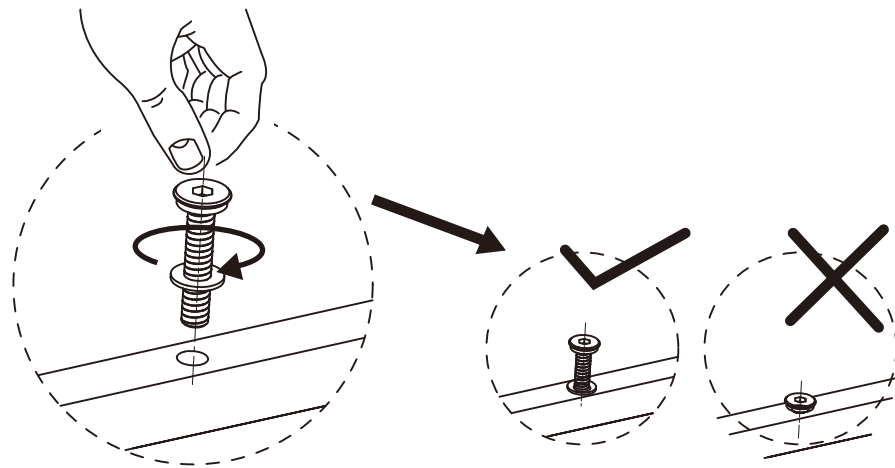
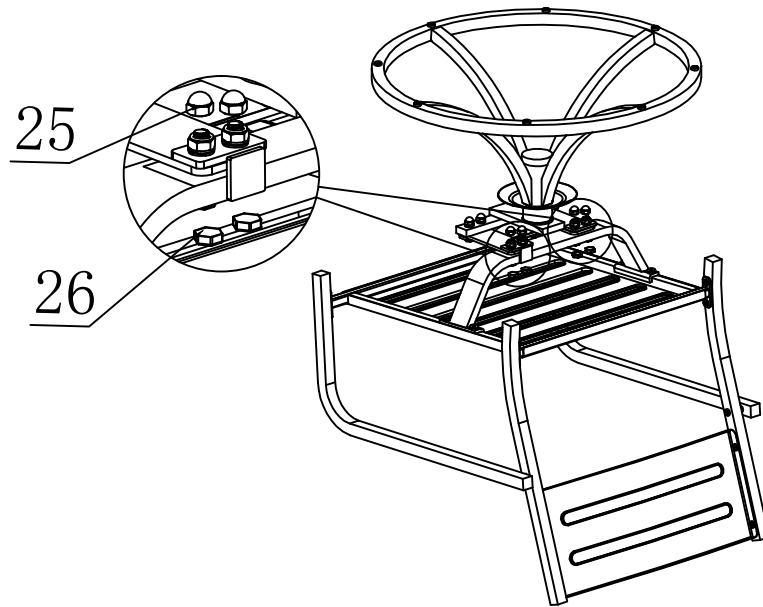

Cover the Plastic Cap #25 on the Nuts;
Cover the Plastic Cap #26 on the Bolts.



⑨ 1X



⑪ 4X



⑭ 4X M6*16



⑳ 4X



㉗ 1X

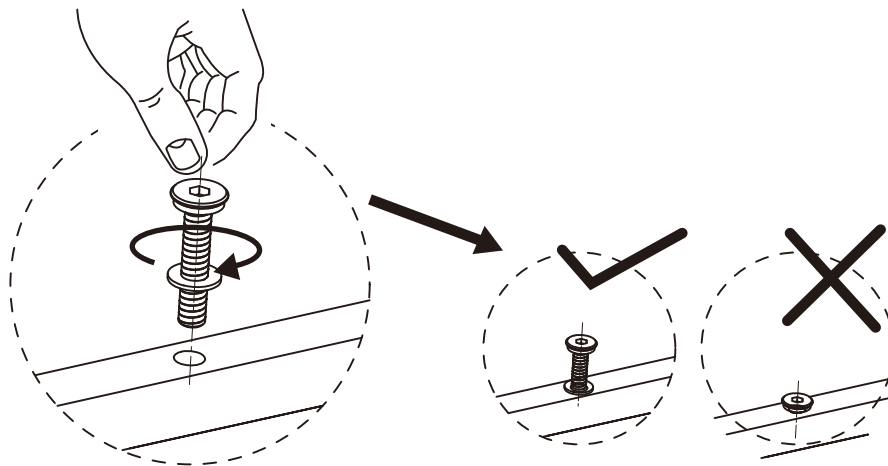
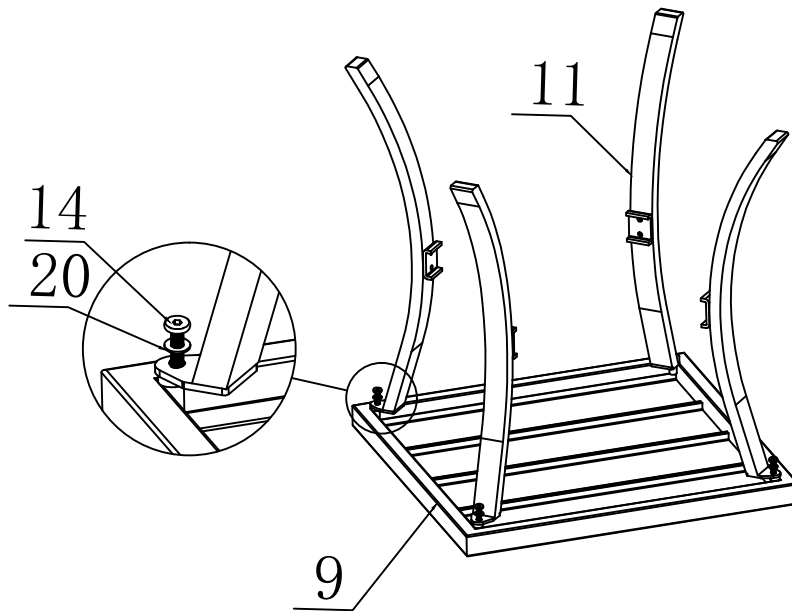

Use 4 M6 x 16 Bolts #14, 4 Washers #20 to Secure the Table Leg #11 to the Table Top #9.

NOTE:DO NOT TIGHTEN THE BOLTS COMPLETELY.



⑩ 1X



⑩ 8X M6*22



⑩ 8X



⑩ 1X

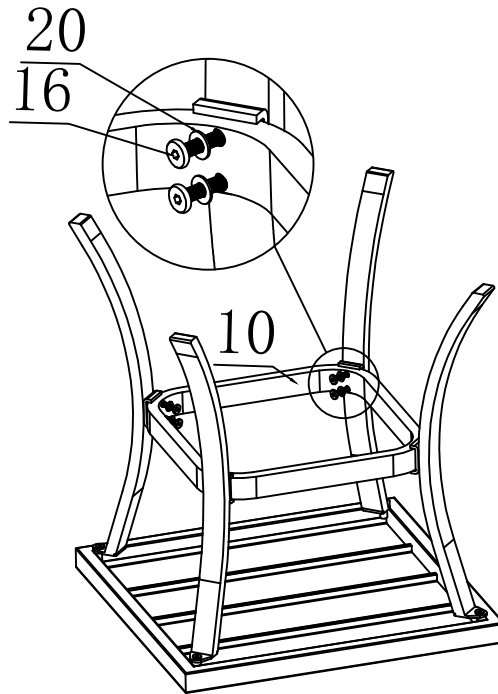

Use 8 M6 x 22 Bolts #16, 8 Washers #20 to secure the Leg Brace #10 to the Table Leg #11.

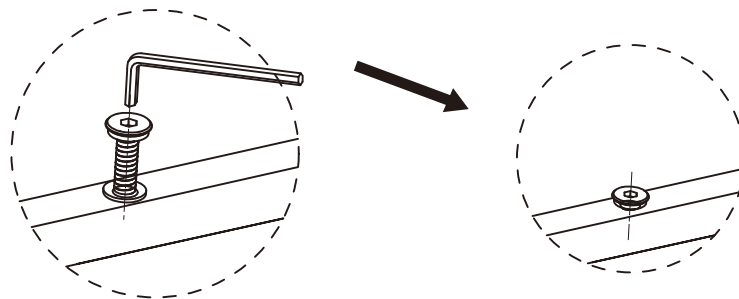

10

Tighten all the Bolts into Place.



⑫ 12X

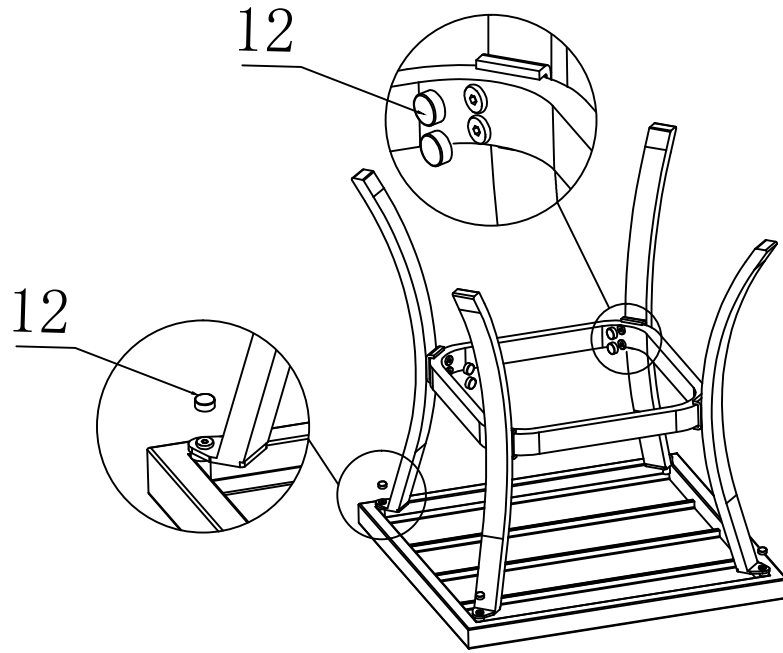

Cover the Plastic Cap #12 on the Bolts.

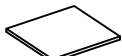

29

2X

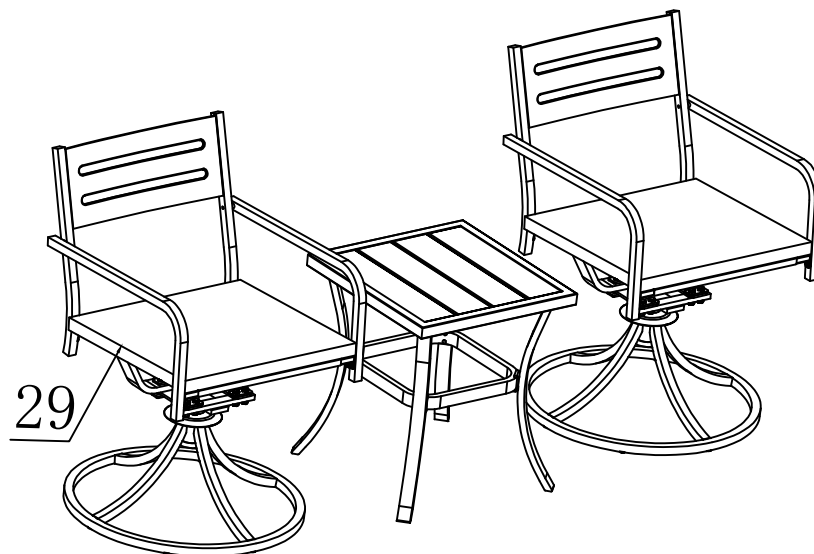

Place #29 Seat Cushion on the Seat Panel.

NOTE: IF ANY SCREW HOLES CANNOT BE ALIGNED, LOOSEN ALL THE SCREWS AND GO BACK TO THE FIRST STEP AND RESTART ASSEMBLY.



Thanks for your purchase.

At domi outdoor living, we believe in our products.

That's why we provide a 12-month warranty and friendly, easy-to-reach after-sales service. So, if you have any questions about our product or assembly, please feel free to contact us. We are here for you.

Support:  

After-sales contact email:

service@domioutdoorliving.com

Business cooperation contact email:

marketing@domioutdoorliving.com

Please have your order ID available if you reach out for support.

If you have damaged parts or product, please send us photos for an immediate response.