

Owner Manual

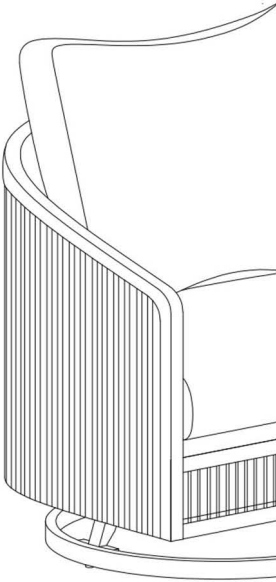

WARRANTY

We strive to offer high quality product and we also try our best to satisfy each customer that order from us, no matter on products or services as needed. Each customer receives a record of their order, such as the order number or item receipt. For any items that are out of warranty period, you may still be able to purchase the replacement parts from our company if they are available.



MAINTENANCE AND WARNING

Please read the manual thoroughly
before you start installing.

Please keep the product away from
sharp object.

Packaging and small parts may have
chocking hazard, please keep them away
from children and pets.

Please clean the product according to each
clean code, check the product description
for more information.

Please keep the product away from
fire.

If you have any other questions, please
contact us, we will be glad to help you out.

If the product is placed under direct
sunlight, the pattern or color might fade
away overtime.

Check the product periodically to make
sure everything is secured and tightened.

Always use proper tools for installation.

Do not jump on the product.



Two people



0-3

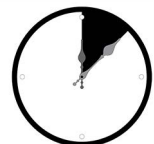

Around 60 min

PRODUCT DESCRIPTION



Metal structure is very stable, allowing for three person to use at the same time.

Soft cushions provide ultimate comfort, designed for long time sitting.

Hollow caved design adding aesthetic to the overall appearance.

Metal made chair has quality of weather resistant, perfect for harsh outdoor environments.

Easy to install, the instruction is very clear.

EXPLODED VIEW

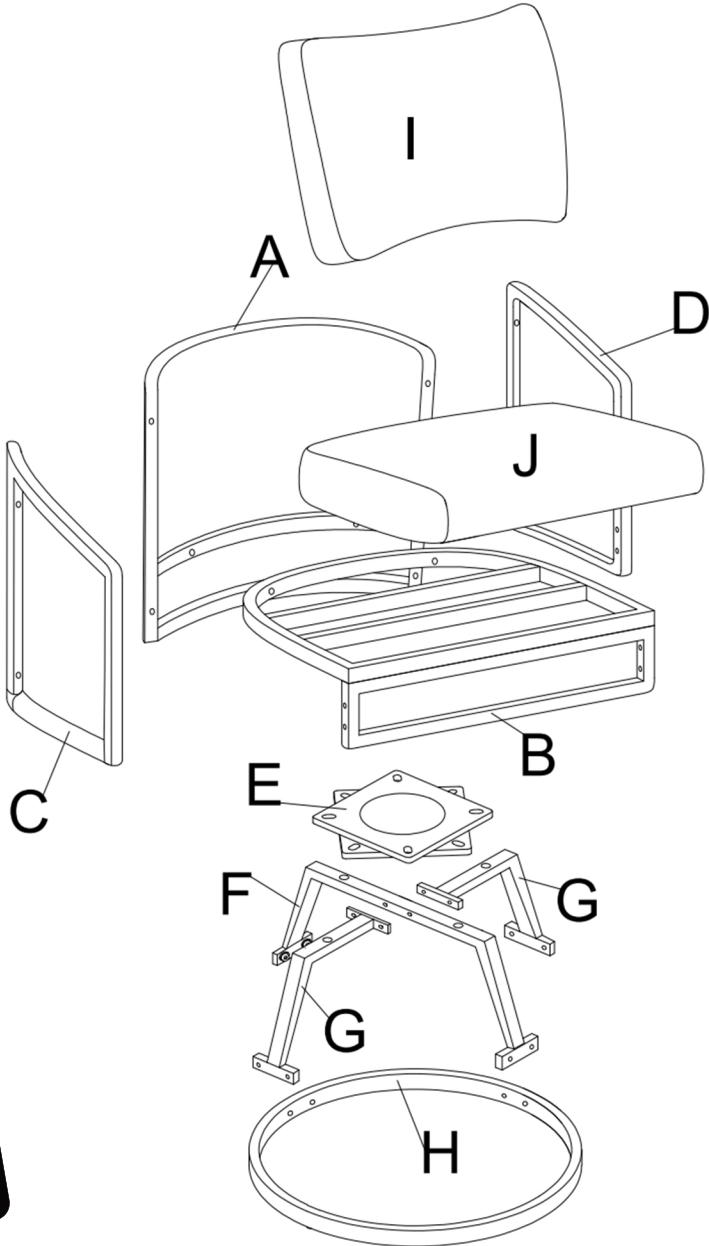

PARTS

A*2

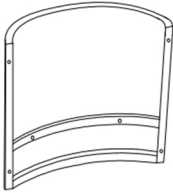

Backrest

B*2

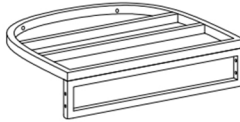

Seat frame

C*2



Right frame

D*2



Left frame

E*2

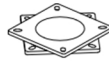

The rotary base

F*2

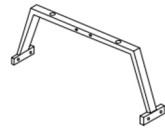

Supporting bar

G*4



Supporting bar

H*2

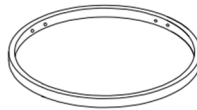

The base ring

I*2

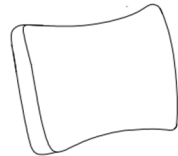

Back cushion

J*2



Seat cushion

HARDWARE

TOOL LIST

NOTE: Designated with (★) We provide additional spare parts in the hardware package

①*16

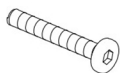

★ M6*40mm
Bolt

②*16

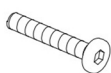

★ M6*35mm
Bolt

③*16



★ M6*20mm
Bolt

④*8



★ M6*15mm
Bolt

⑤*68



★ Flat washer

⑥*12



★ Nut

⑦*1



Hexagon
wrench

⑧*1



Allen key

Please make sure all hardware&packing material fitting the list.

Especially some small accessories may be missing during transportation. Please contact us if you have any question.

step 1

Take out the cushions (J) from the compression bags, and allow it to recover to its original shape, it might take up to 24 hours to be fully recovered, you may gently slap on them to speed up the process.

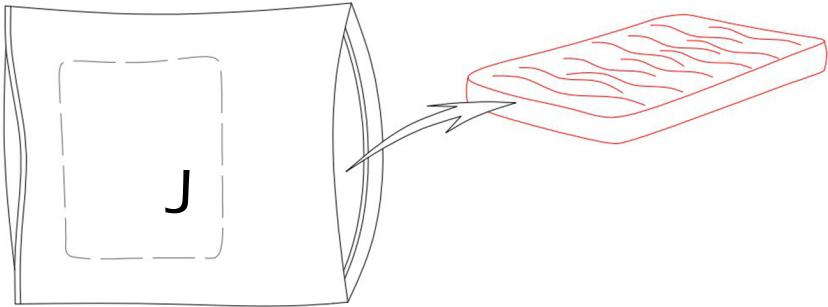

X2

step 2

Connect the back frame (A) with the seat frame (B). Place one flat washer (5) onto each bolt (2), then use the allen wrench (8) to tighten the bolts as shown. Make sure all the bolts are fully tightened.

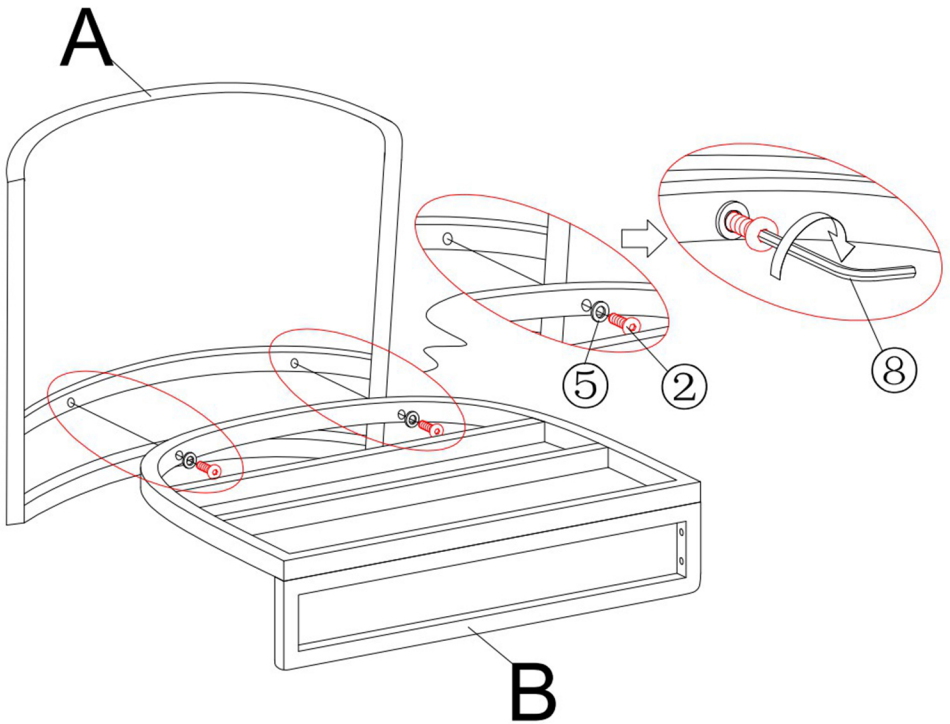

X2

You may place the backrest flat on the ground to install.

step 3

Install left and right armrest (C & D) to the seat frame as shown. Place one flat washer (5) onto each bolt (1), and use the allen wrench provided to tighten the bolts, make sure they are all fully tightened before next step.

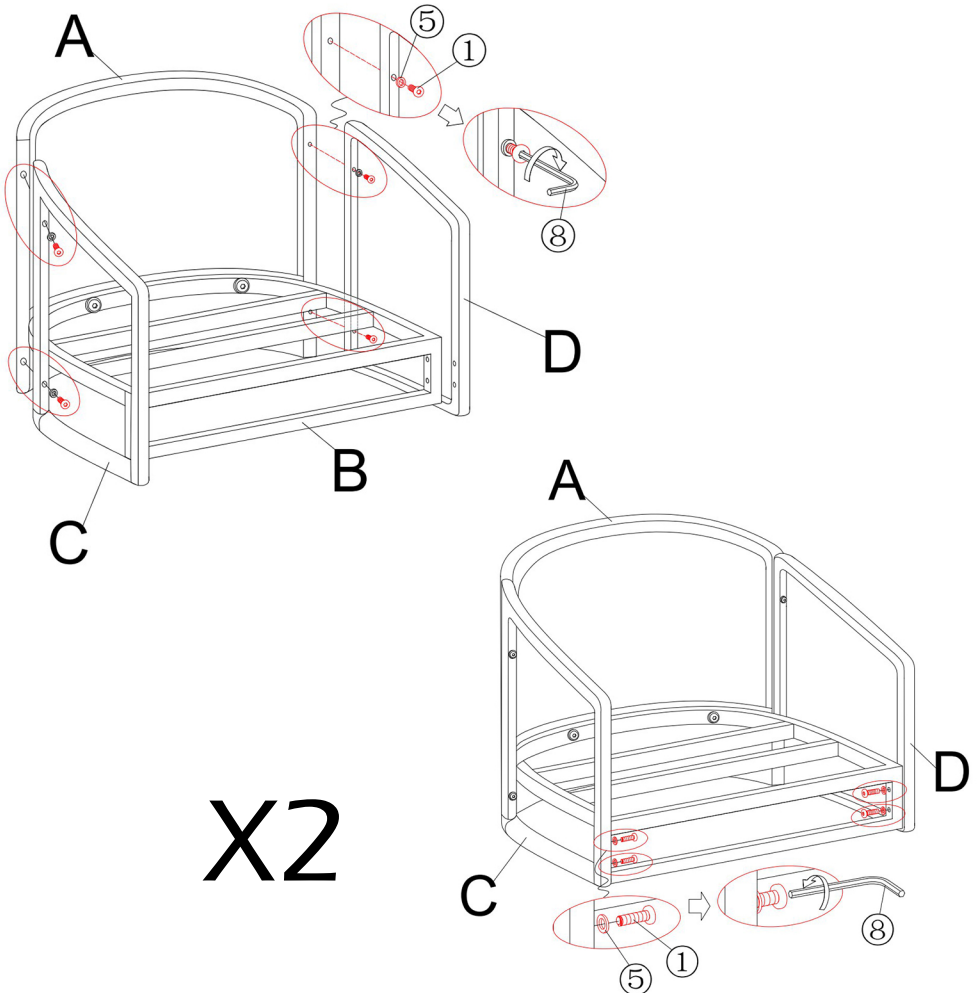

Note: We suggest tighten all bolts by 30-50% first, check all bolts are in correct position before fully tighten.

step 4

Install the supporting bar (F) onto the base ring (H) as shown. Place one flat washer (5) onto each bolt (3), then use the allen wrench provided to tighten all the bolts.

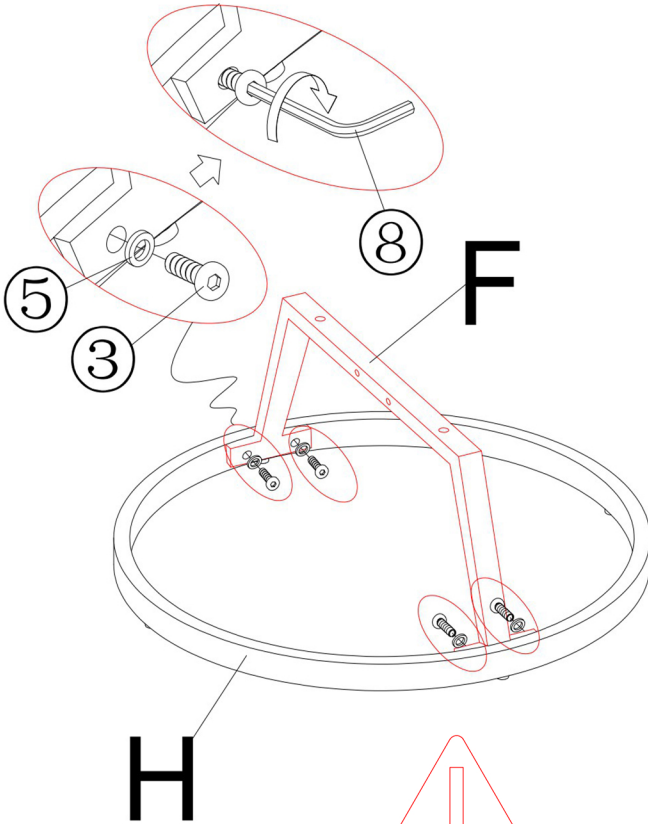

X2

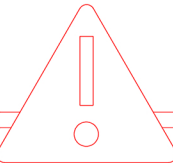

When installing the part F, you can install one side with the screws first, then press the other side hard to align the screw holes, and tighten all screws with the allen wrench provided.

step 5

Connect the supporting bars (G) onto the previous part as shown. The parts that connect to the base ring (H) need two bolts (3) on each sides, and make sure to place one flat washer (5) before tighten. The parts that connect to the supporting bar (F), please use the bolts (2) to connect both supporting bars (G) as shown. Use the allen wrench (8) provided to tighten the bolts, and use the hexagon wrench (7) provided to fix the nuts on the other side. Make sure you placed one flat washer (5) on each bolt and nut before tighten.

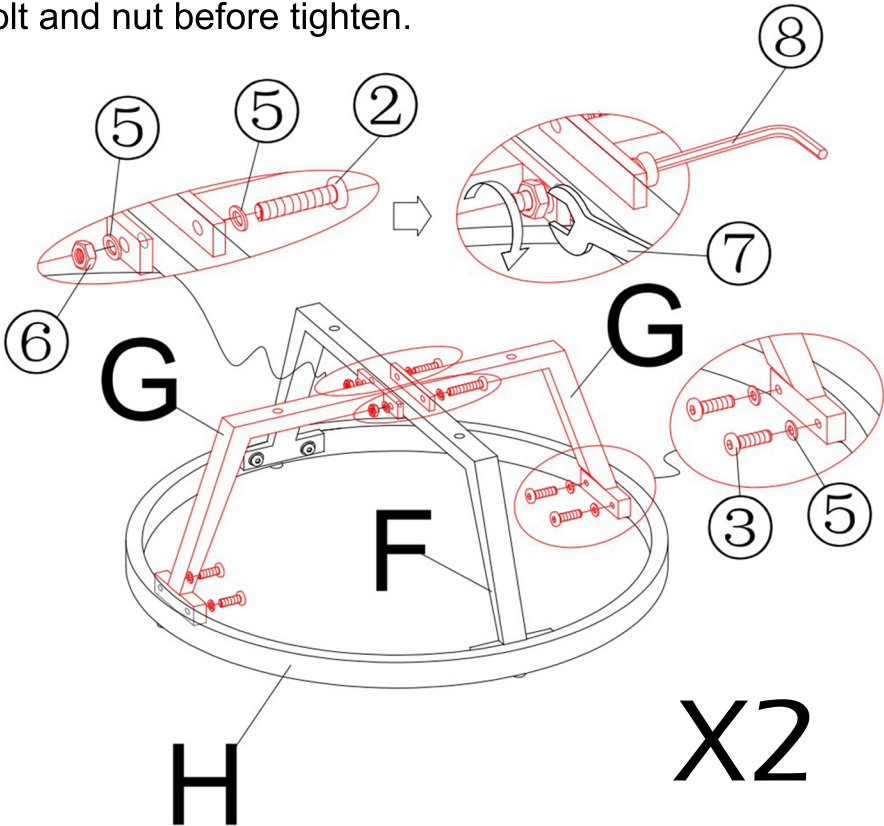

Note: We suggest tighten all bolts by 30-50% first, check all bolts are in correct position before fully tighten. 12 ↗

step 6

Connect the rotary base (E) onto the supporting bar as shown. Place one nut (6)&flat washer(5) underneath to fix each bolt (2)&flat washer(5), use the allen wrench (8) provided to tighten all the bolts while using the hexagon wrench (7) to fix the nuts.

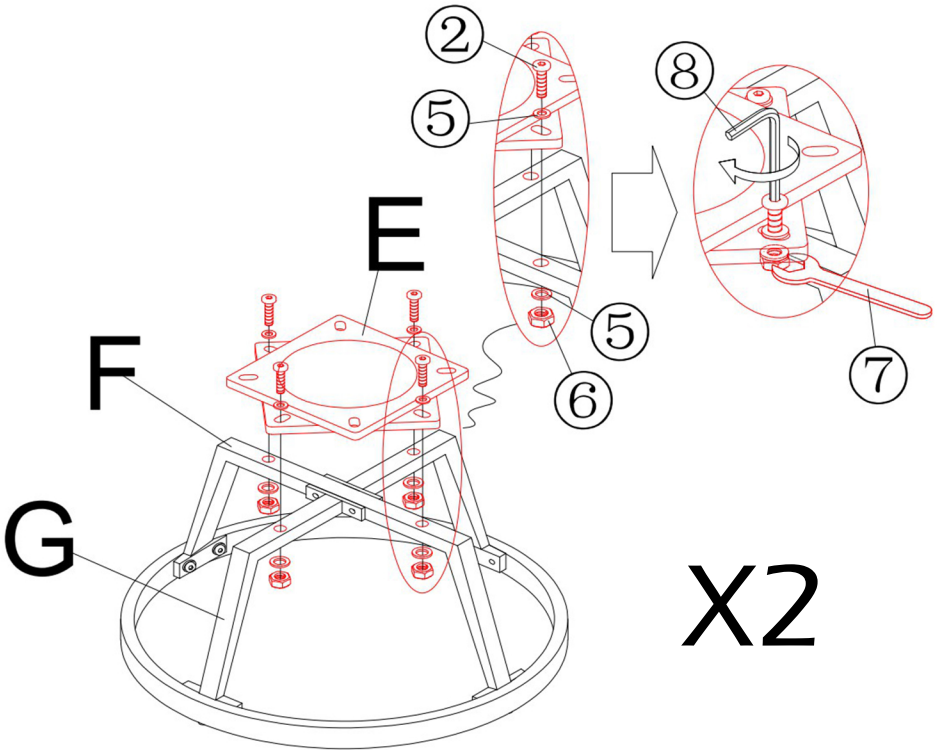

step 7

Align the seat frame onto the rotary base as shown, make sure they are correctly aligned. Then place one flat washer (5) onto each bolt (4), and use the allen wrench (8) provided to tighten all the bolts.

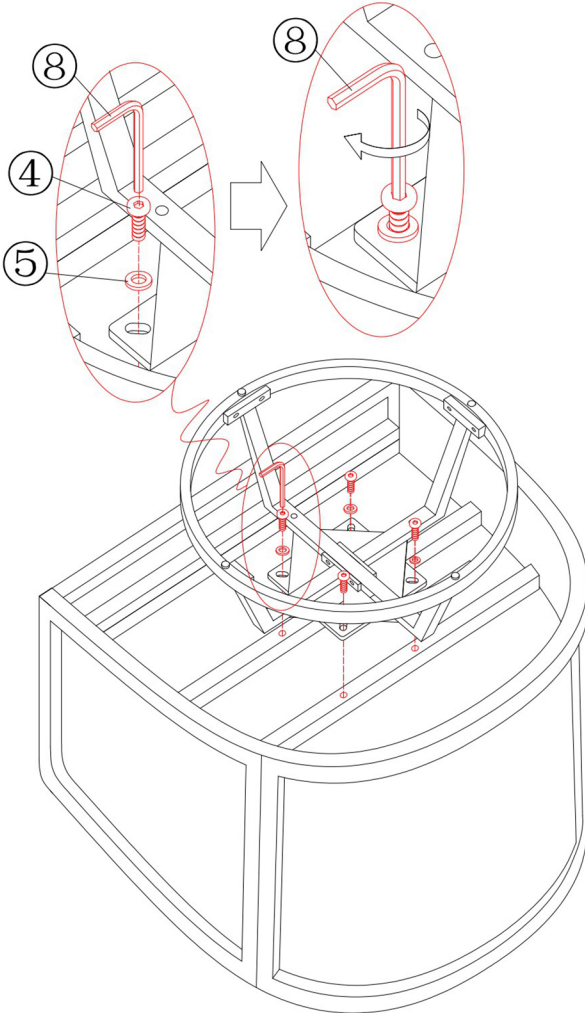

X2

Note: We suggest tighten all bolts by 30-50% first, check all bolts are in correct position before fully tighten.

step 8

Place the seat cushion (J) onto the chair.

Place the back cushion (I) onto the chair.

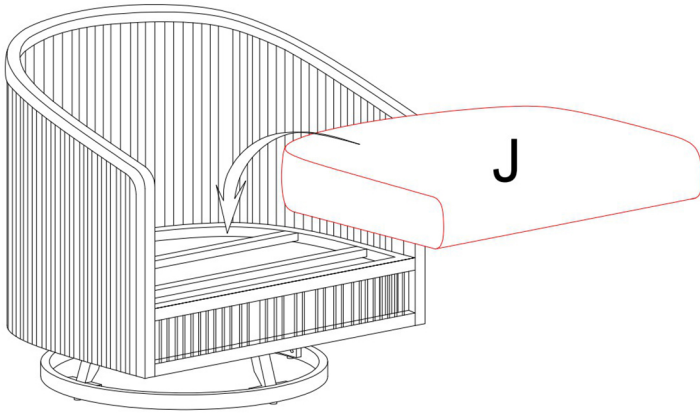

X2

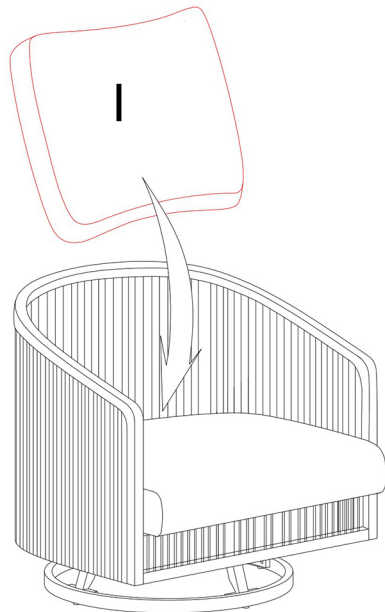

If the base is slightly unflat after install, simply adjust by rotating the foot nails underneath the base ring.

step 9

The assembly is completed, thank you for choosing our product, please enjoy!

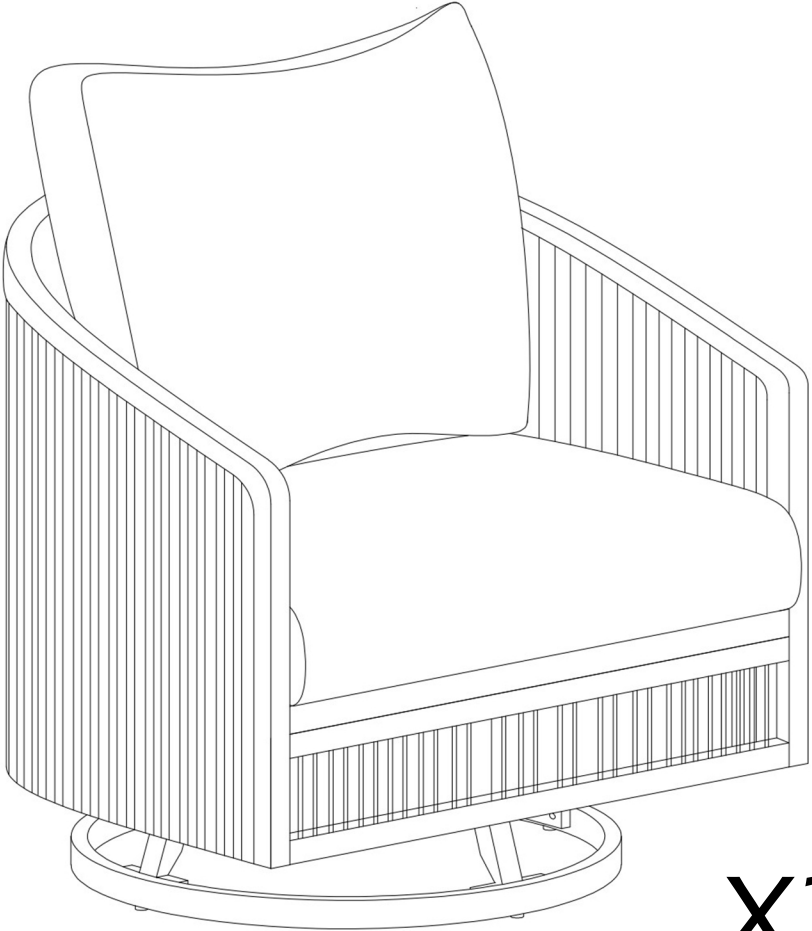

X2

WARRANTY

We strive to offer high quality product and we also try our best to satisfy each customer that order from us, no matter on products or services as needed. Each customer receives a record of their order, such as the order number or item receipt. For any items that are out of warranty period, you may still be able to purchase the replacement parts from our company if they are available.

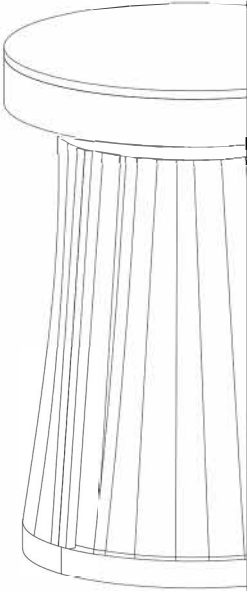

EXPLODED VIEW

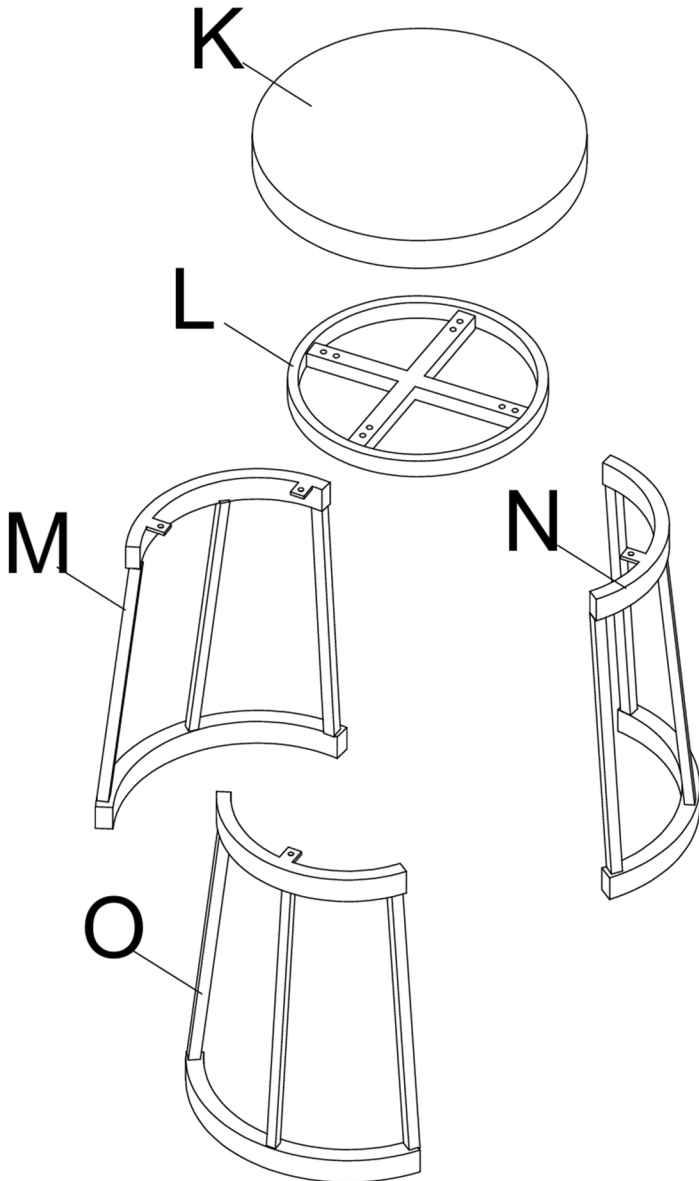

PARTS---coffee table

K*1

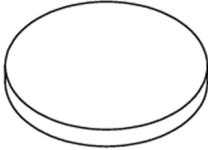

Stool top

L*1



Stool frame

M*1

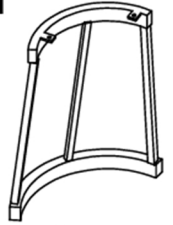

Leg

N*1

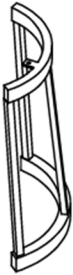

Leg

O*1

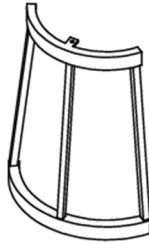

Leg

HARDWARE

TOOL LIST

NOTE: Designated with (★) We provide additional spare parts in the hardware package

②*10



★M6*35mm
Bolt

⑩*4



★M6*15mm
Bolt

⑤*14



★Flat washer

⑧*1

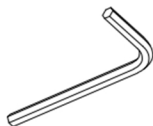

Allen key

Please make sure all hardware&packing material fitting the list. Especially some small accessories may be missing during transportation. Please contact us if you have any question.

step 1

Place the table top (K) upside down, then align the frame (L) to the holes on the table top as shown. Place one washer (5) onto each bolt (2) as shown, then tighten the bolts. Make sure they are correctly aligned before fully tighten the bolts.

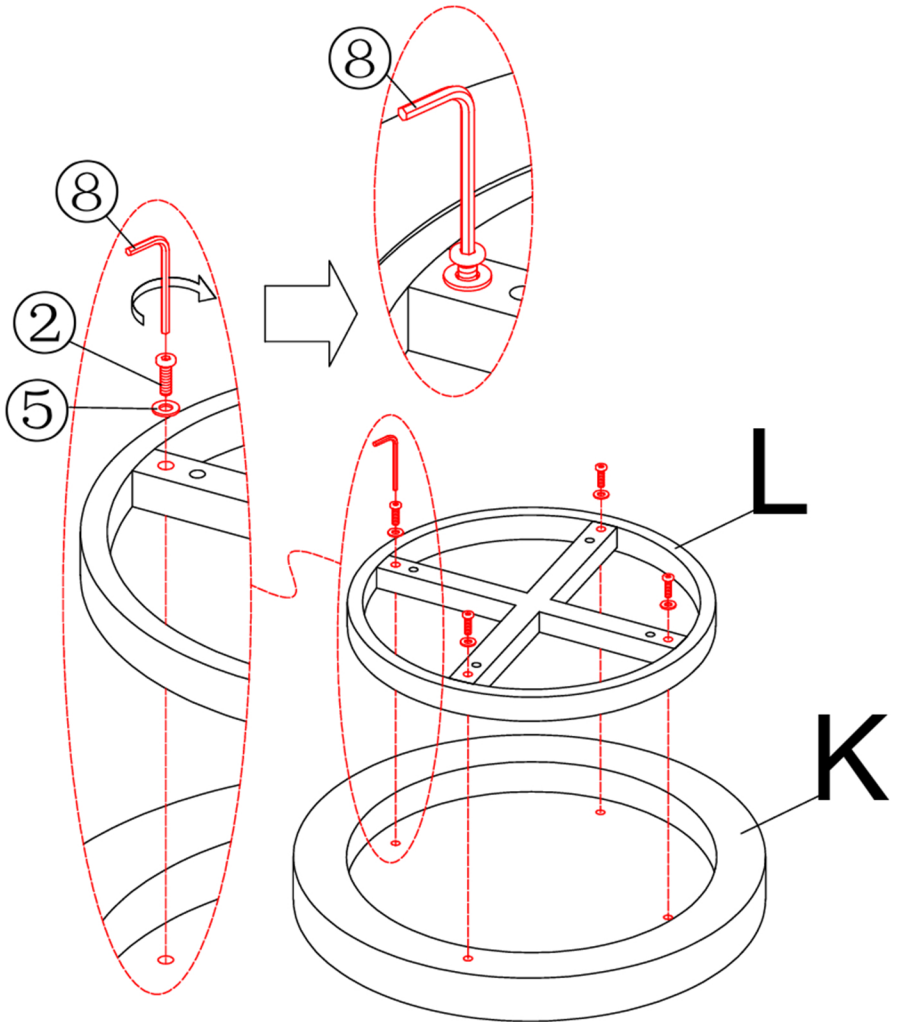

step 2

Place the legs (N,M,O) onto the table top (K) in orders as shown.

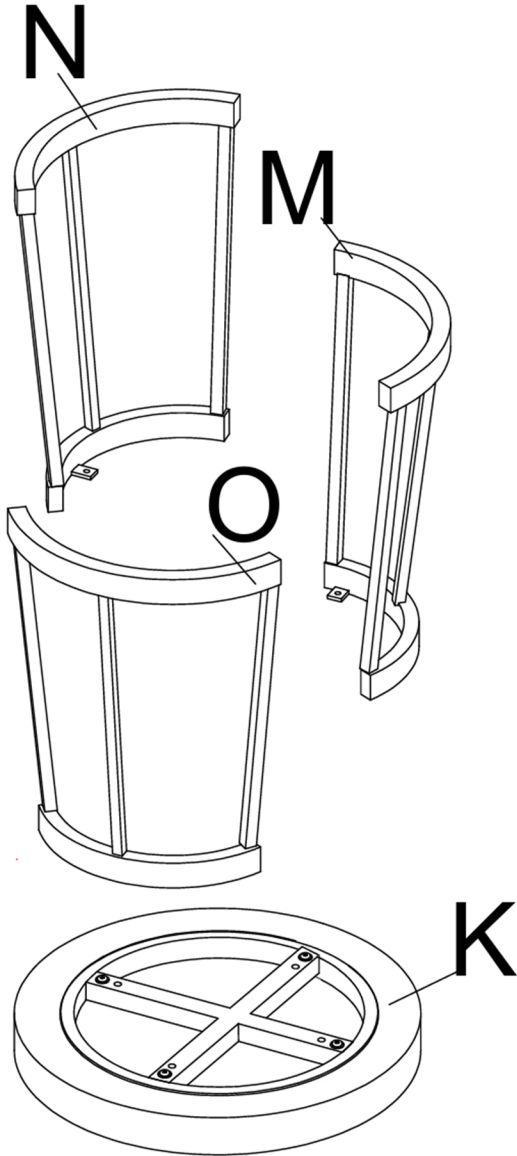

step 3

Install the table legs (N,M,O) onto the frame as shown. Place one flat washer (5) onto each bolt (10), then tighten all the bolts.

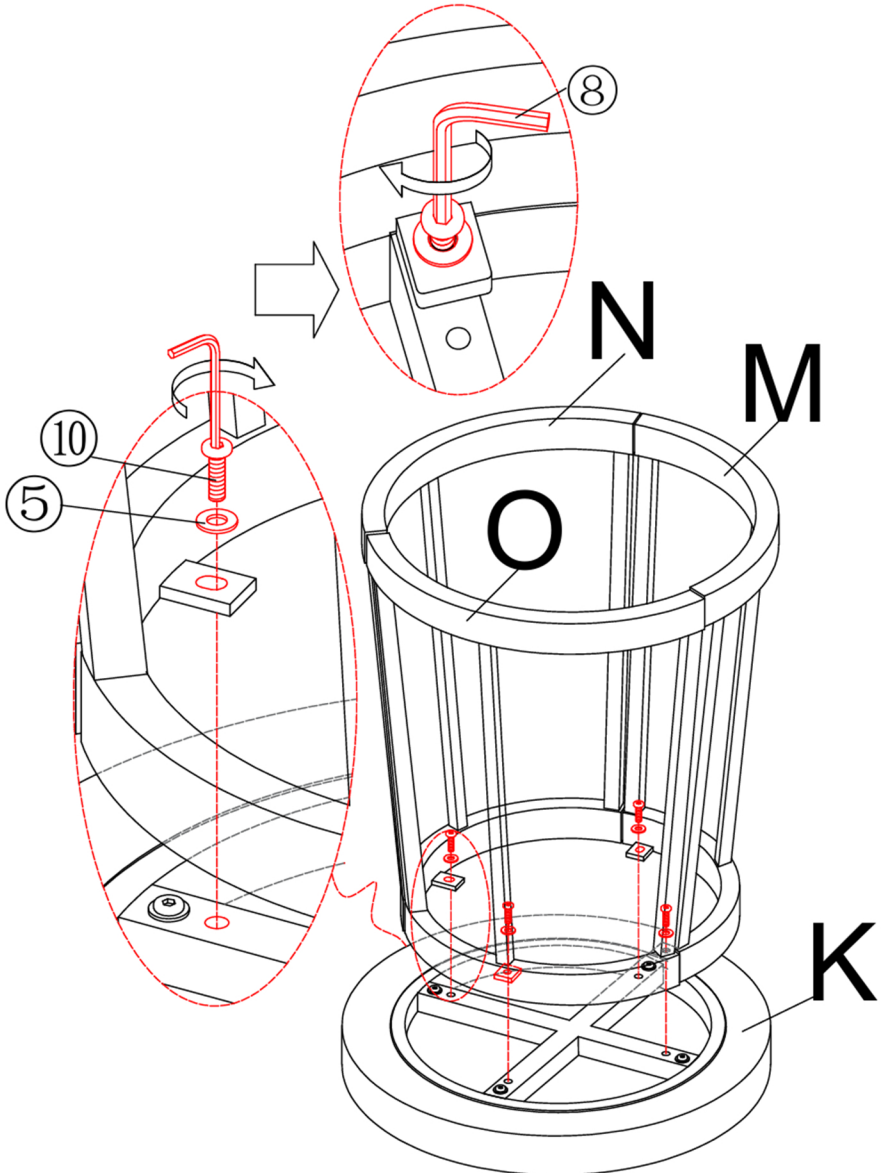

step 4

Fix each leg together by inserting the bolts (2) into the pre-drilled holes as shown, use the allen wrench (8) provided to tighten them. Place one flat washer (5) onto each bolt (2), make sure they are aligned correctly before fully tightened.

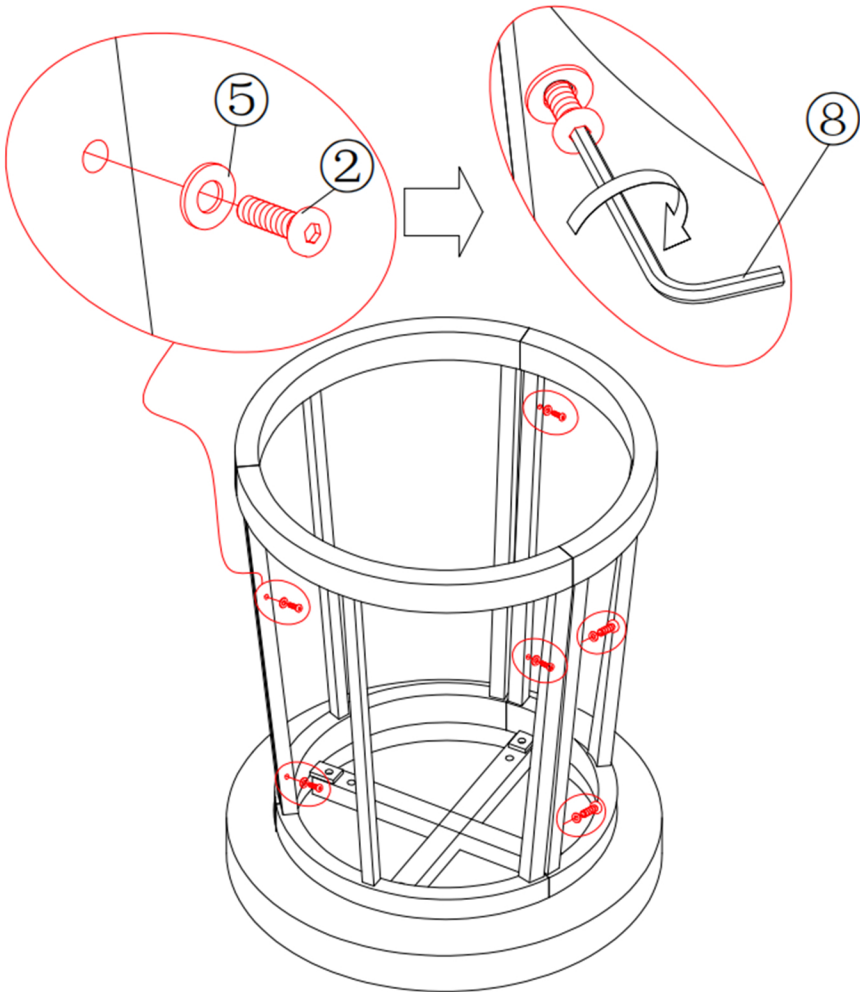

step 5

The assembly is completed, thank you for choosing our product ,please enjoy!

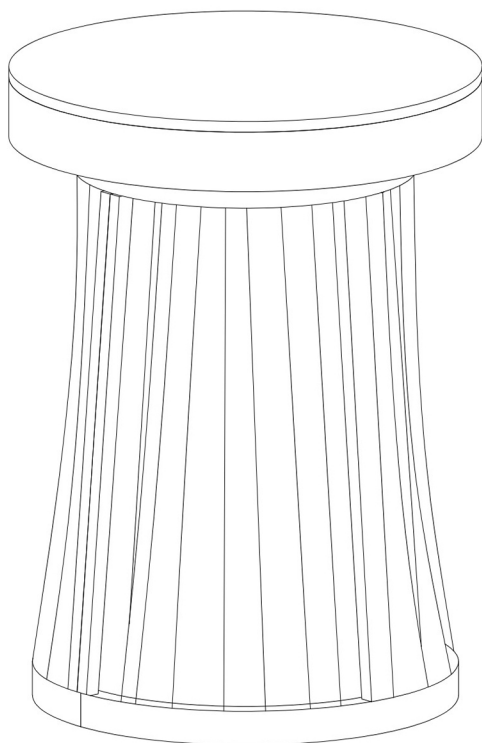

step 6

The assembly is completed, thank you for choosing our product, please enjoy!

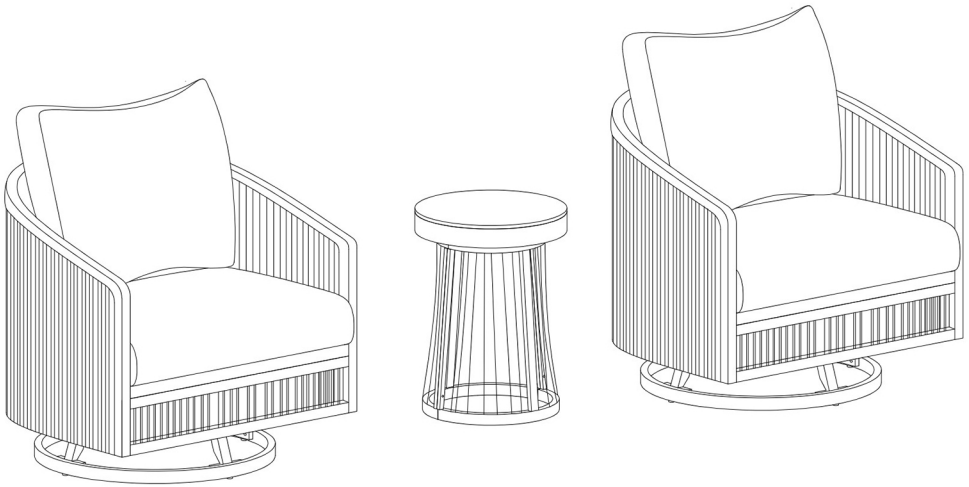

For better user experience, please carefully check all the screws, and make sure they are all fully tightened. (Use the allen wrench to twist each screw until it is fully tightened.)