

Installation instruction

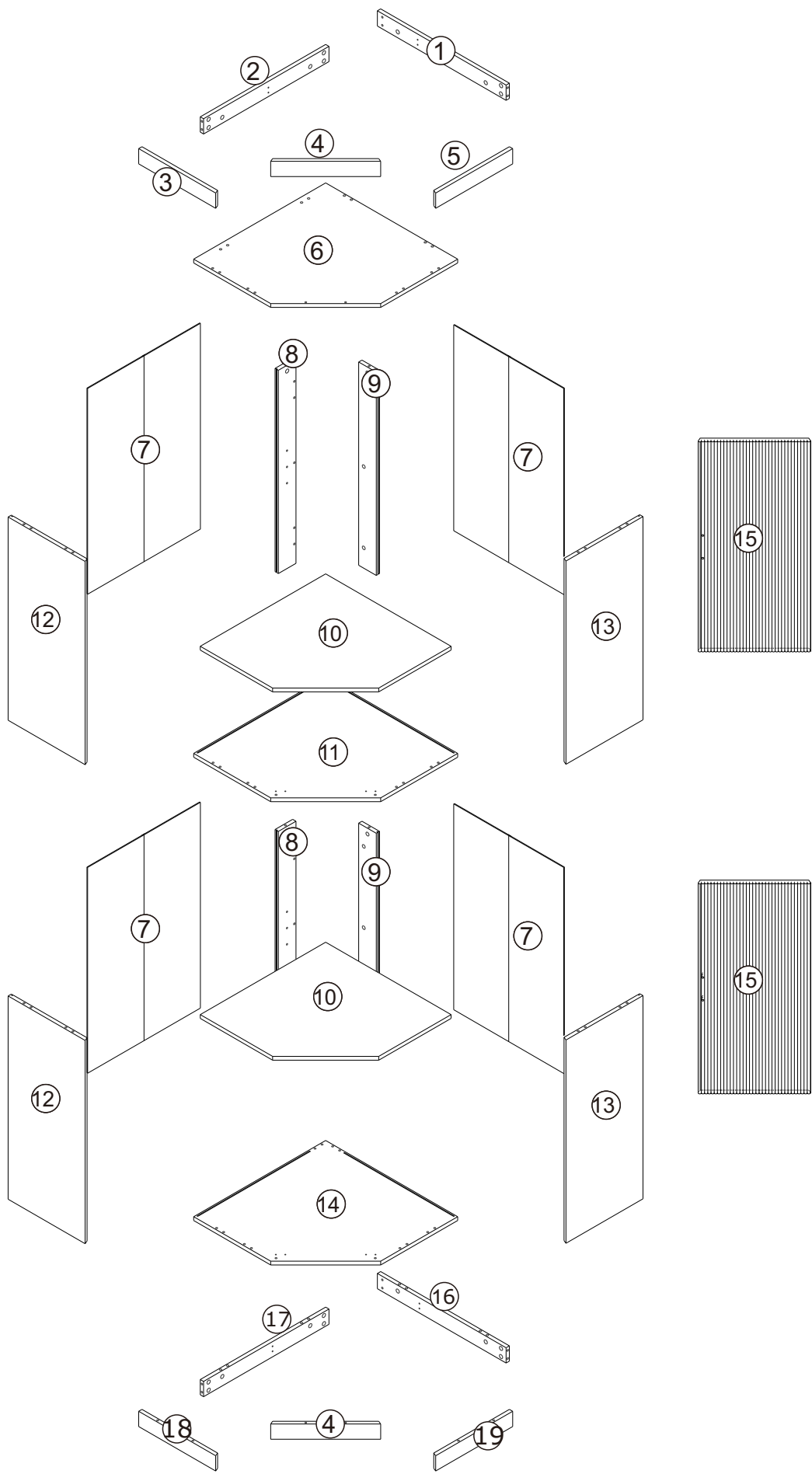

Parts and Operation Elements

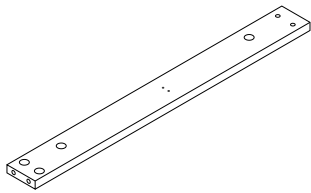

① 1pc

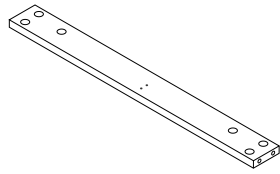

② 1pc

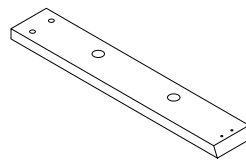

③ 1pc

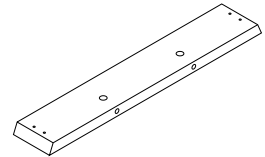

④ 2pcs

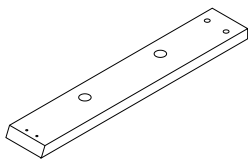

⑤ 1pc

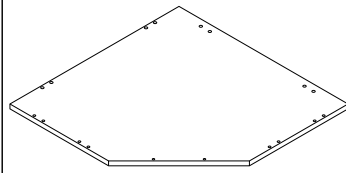

⑥ 1pc

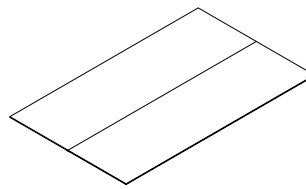

⑦ 4pcs

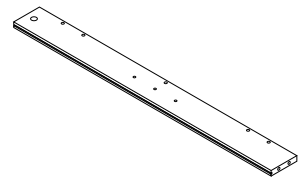

⑧ 2pcs

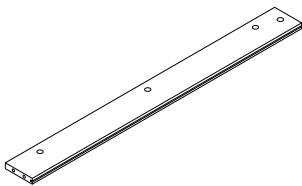

⑨ 2pcs

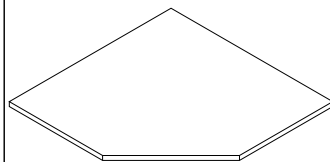

⑩ 2pcs

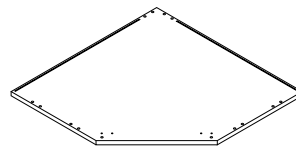

⑪ 1pc

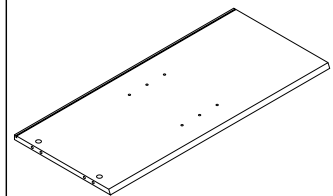

⑫ 2pcs

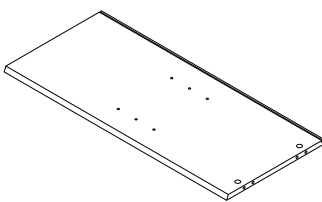

⑬ 2pcs

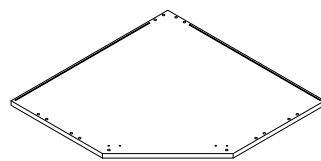

⑭ 1pc

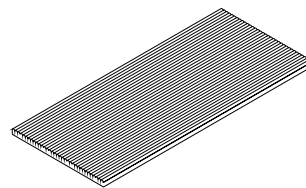

⑮ 2pcs

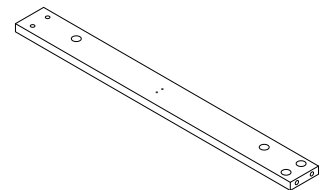

⑯ 1pc

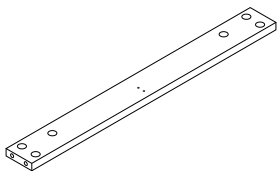

⑰ 1pc

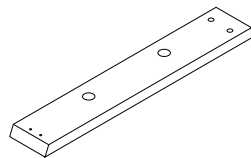



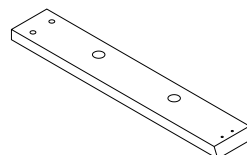





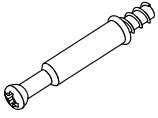

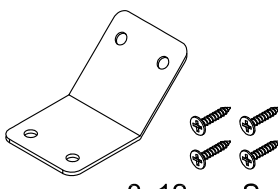
⑱ 1pc

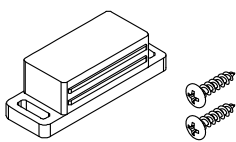

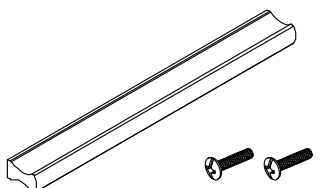
⑲ 1pc

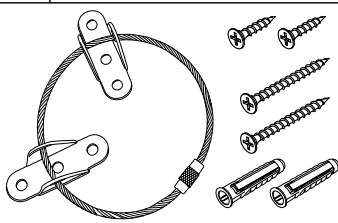
Hardware

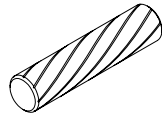
							
A	50+2pcs	B	50+2pcs	C	4pcs	D	12+1pcs
							
E	4pcs	F	10pcs	G	4pcs	H	2pcs
							
I	16pcs	J	1pc	K	4pcs	L	32+2pcs



SPARE BAG

THE SPARE BAG INCLUDED EXTRA HARDWARE FOR DAMAGED OR MISSING SMALL HARDWARE WHILE YOU ARE ASSEMBLING

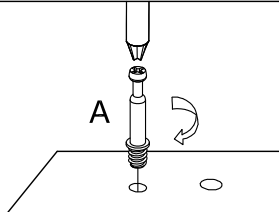
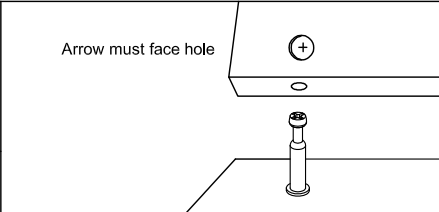
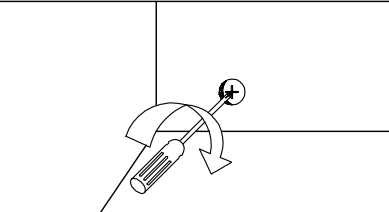
		
Gently screw cam bolt into the threaded anchor	Arrow must face hole	Screw the camlock firmly into locked position.

1

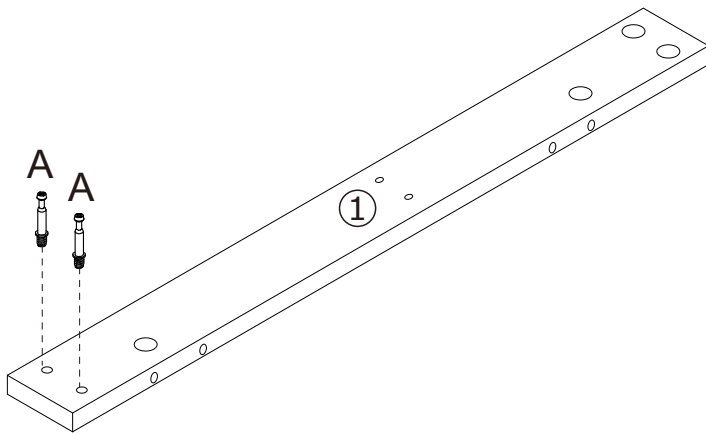
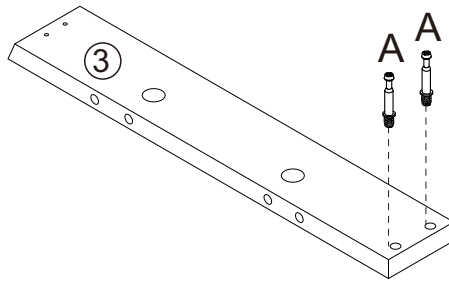
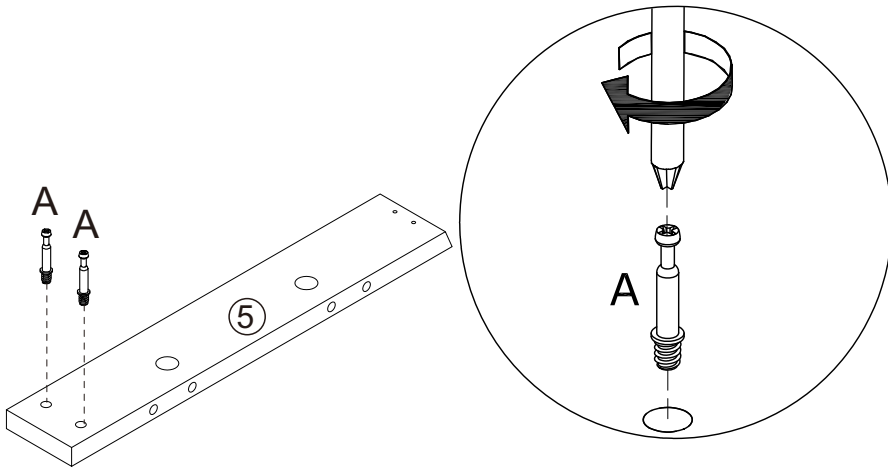
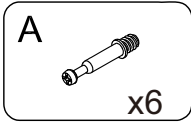

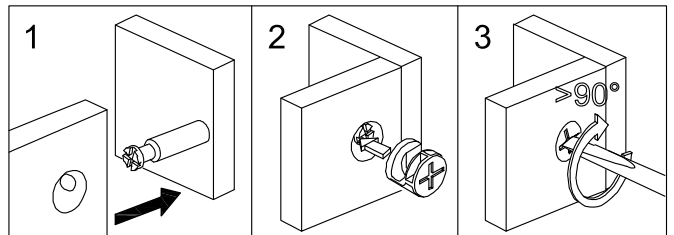
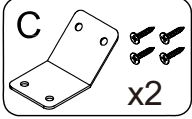
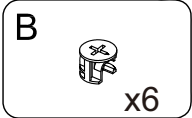
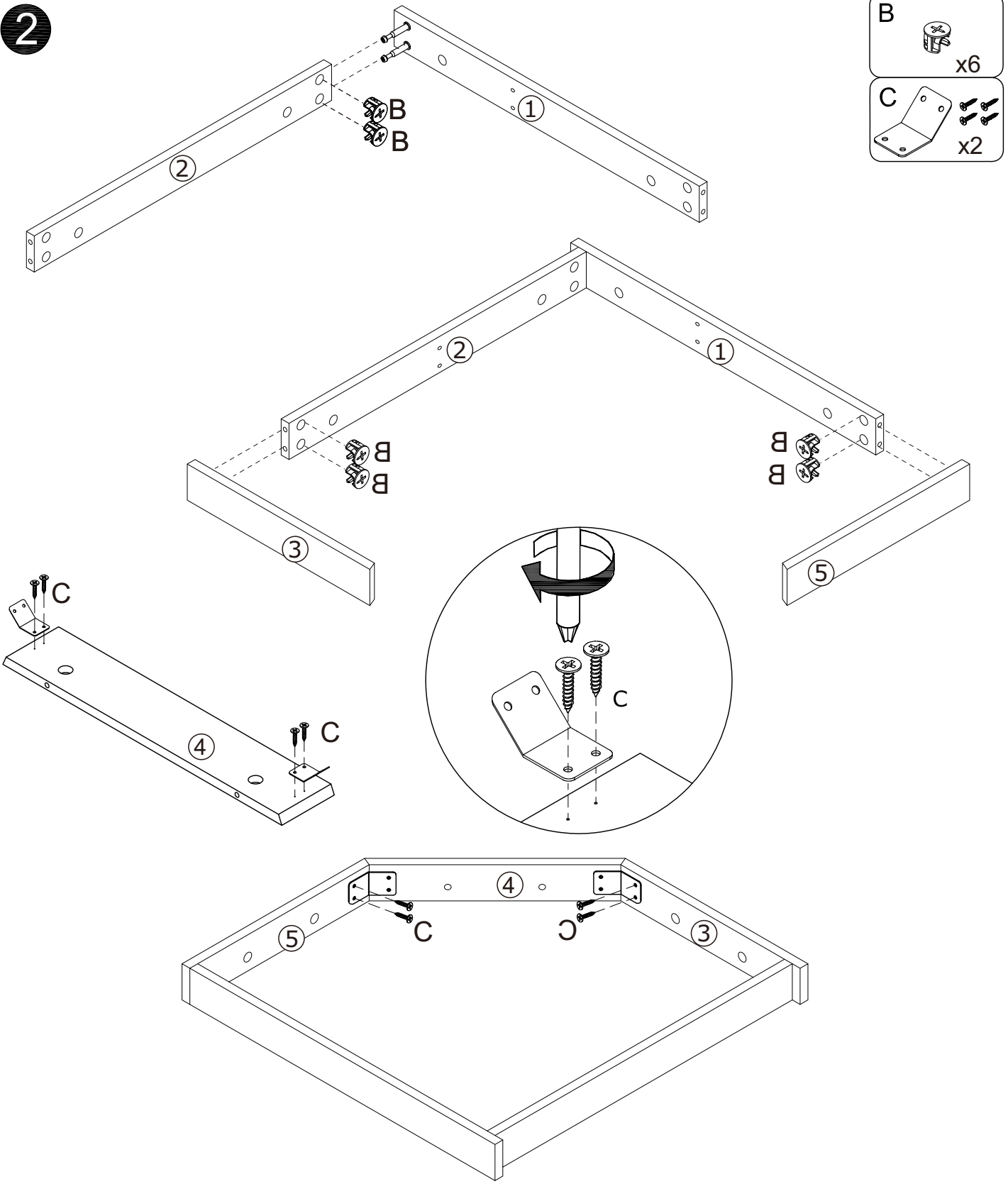

2

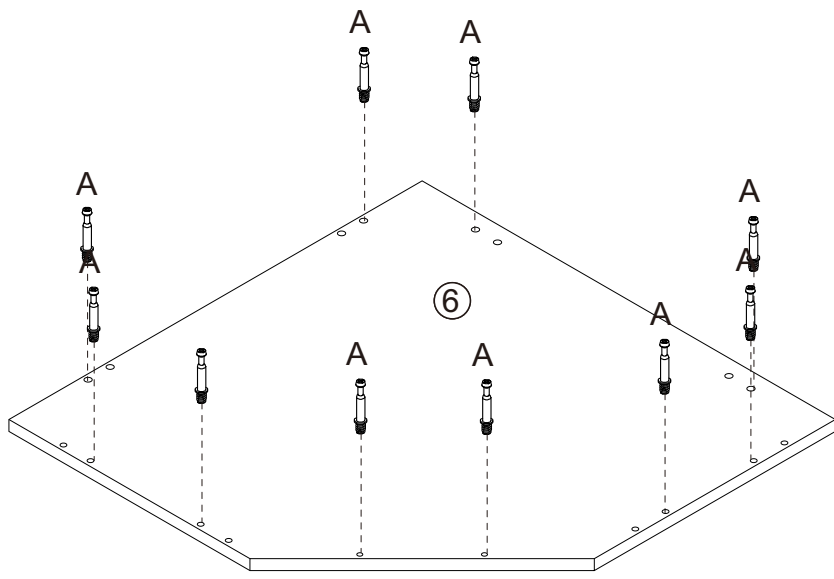

3



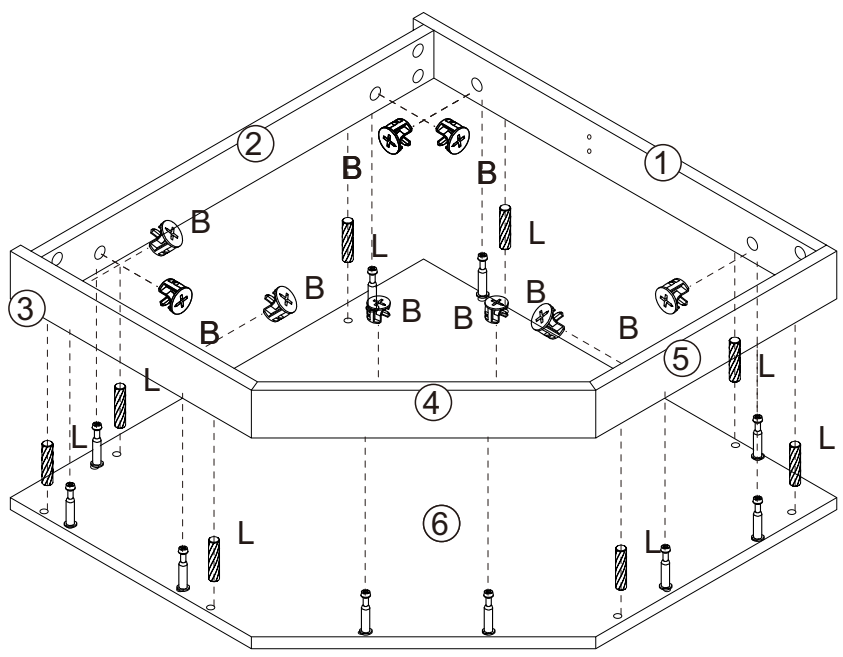

- A  x10
- B  x10
- L  x8

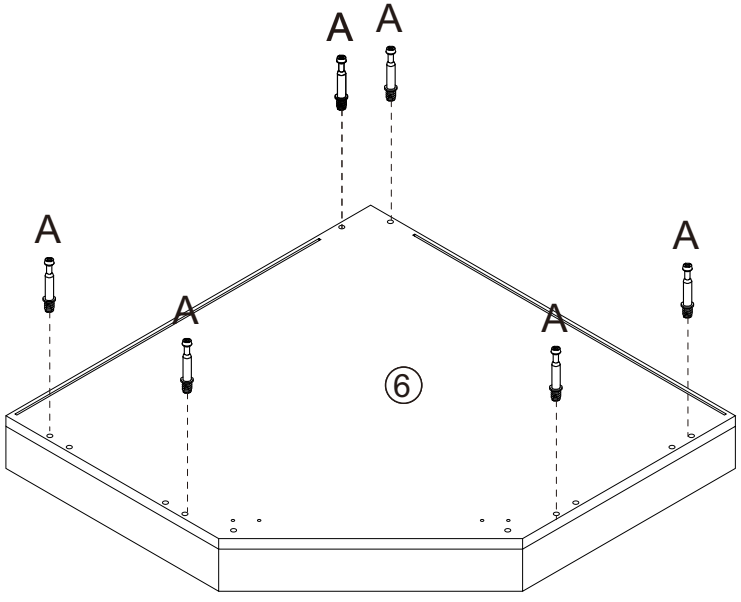

4



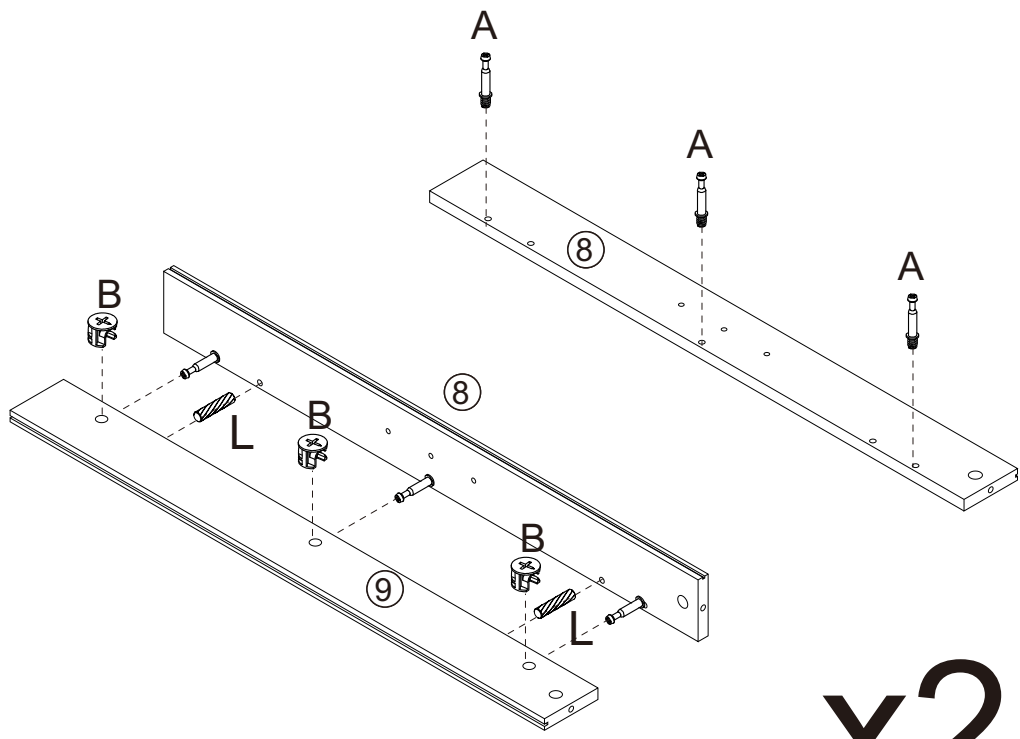

- A  x12
- B  x6
- L  x4



x2

5

- B  x6
- L  x4

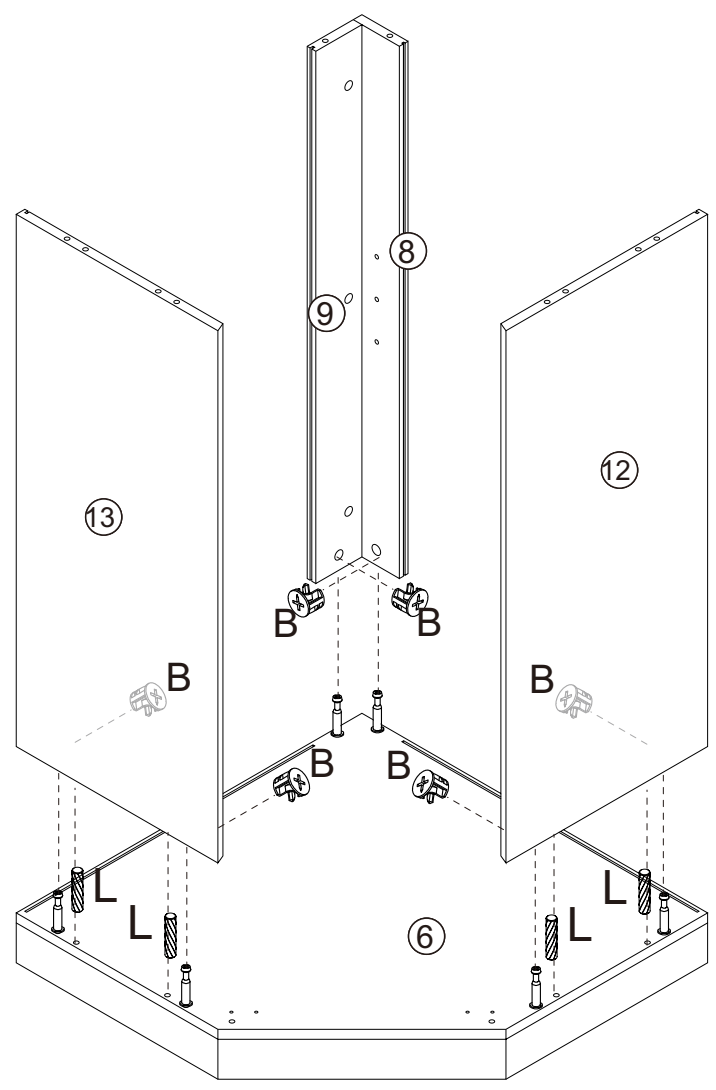

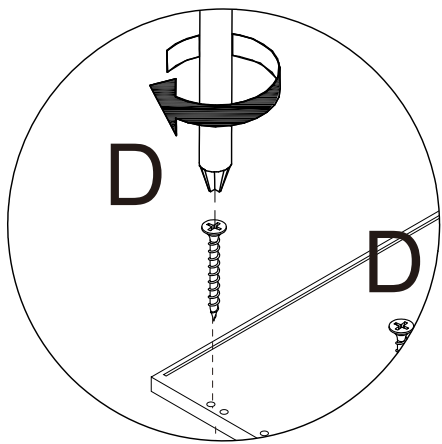
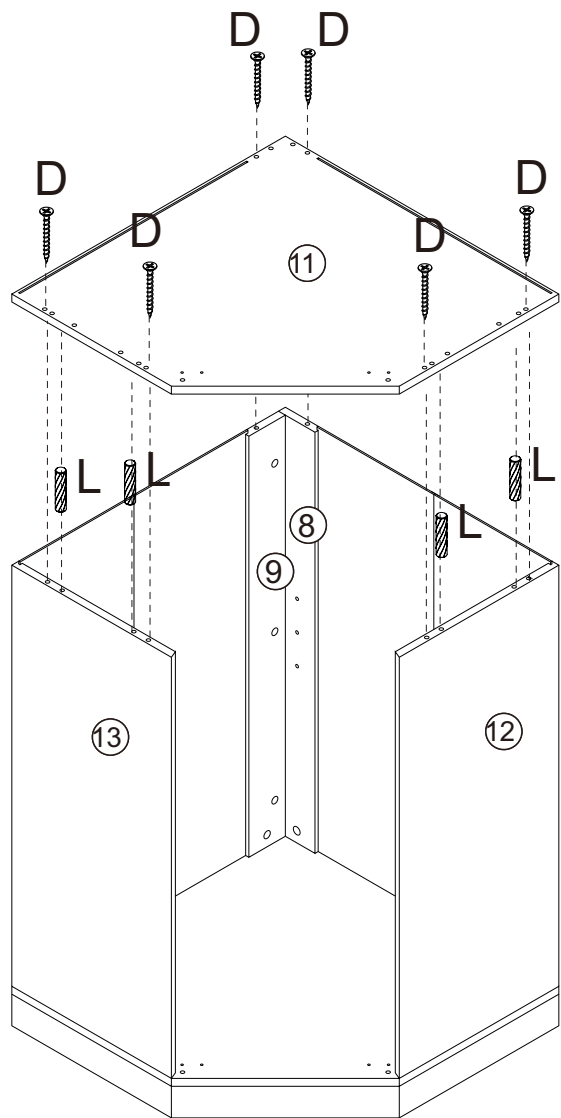
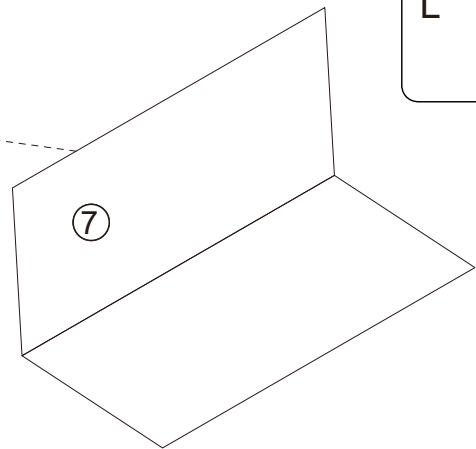
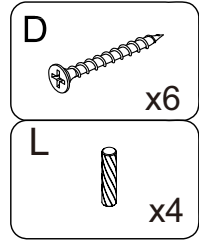
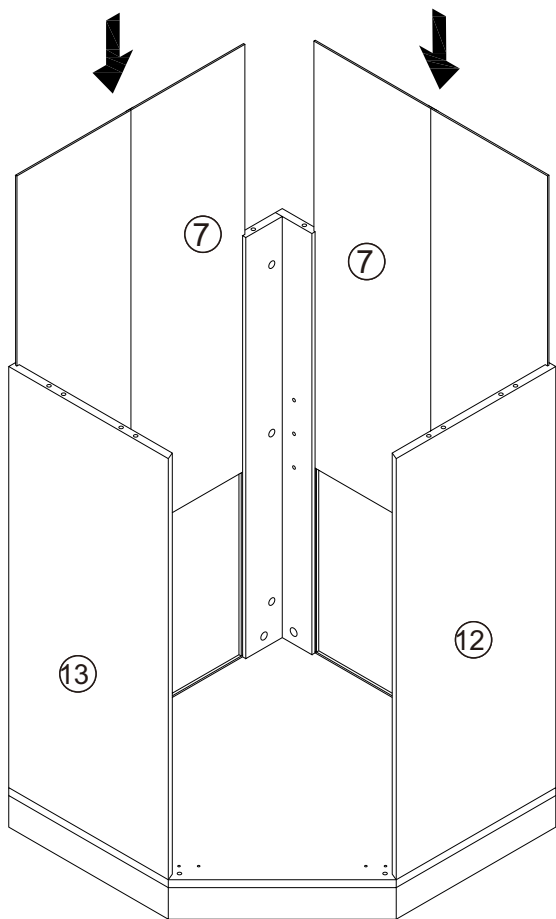

6



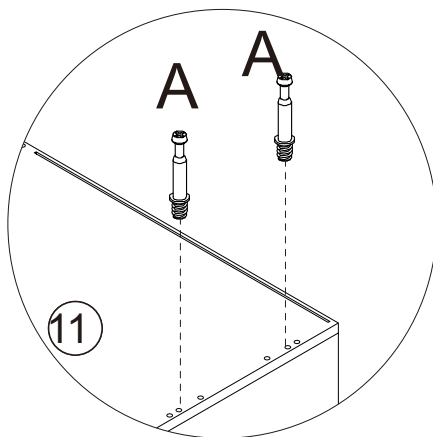
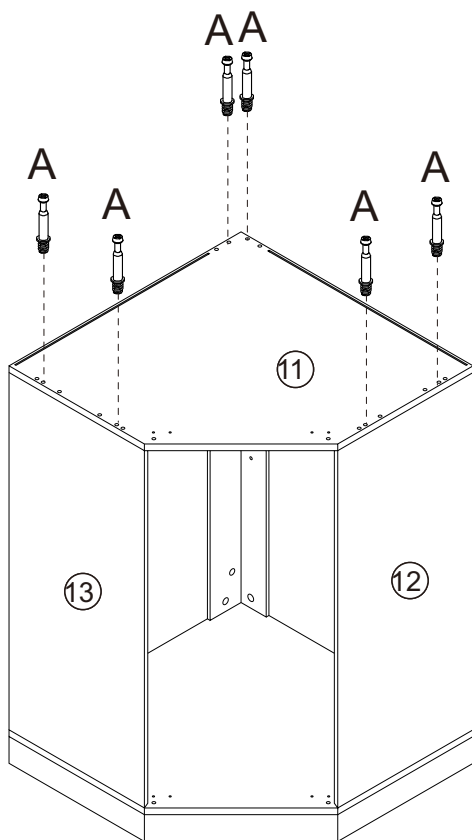

7

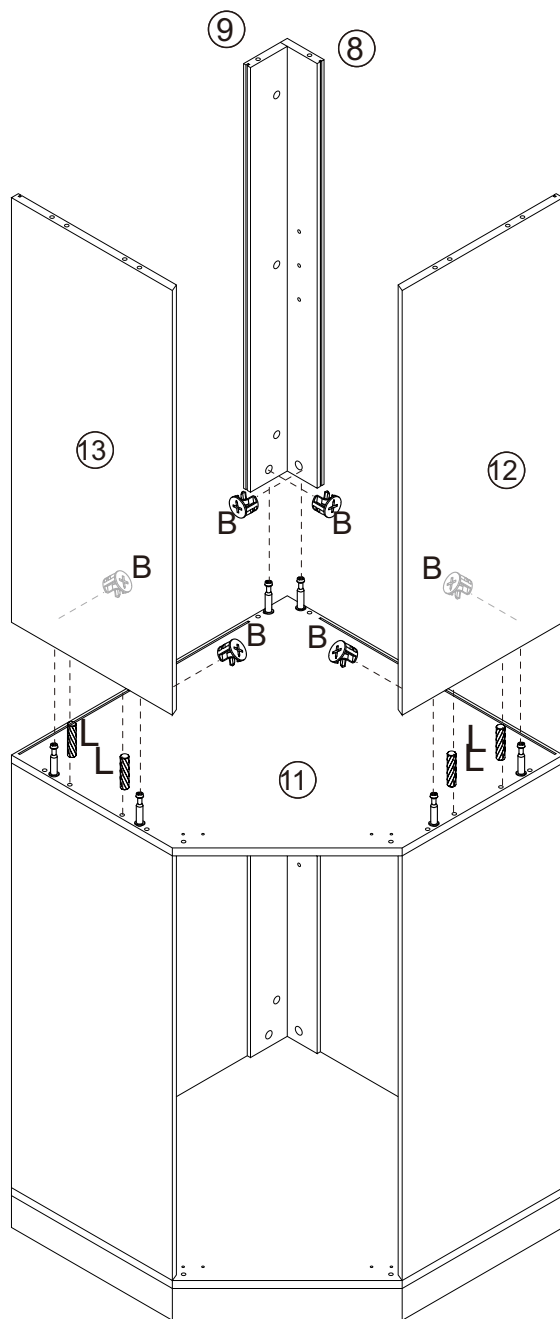

- A  x6
- B  x6
- L  x4



8

- D  x6
- L  x4

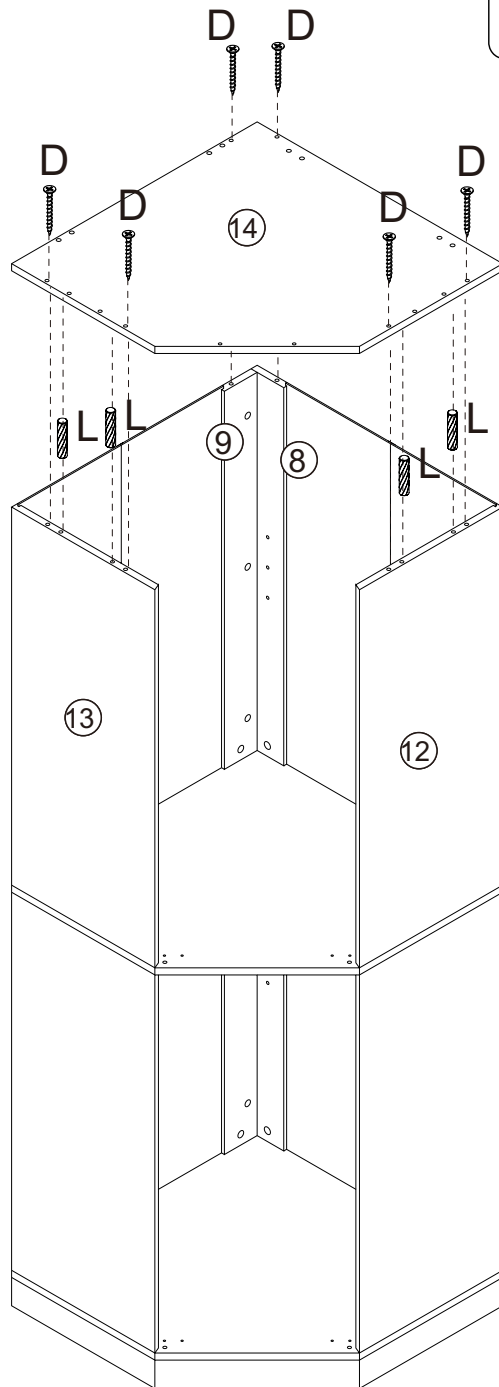
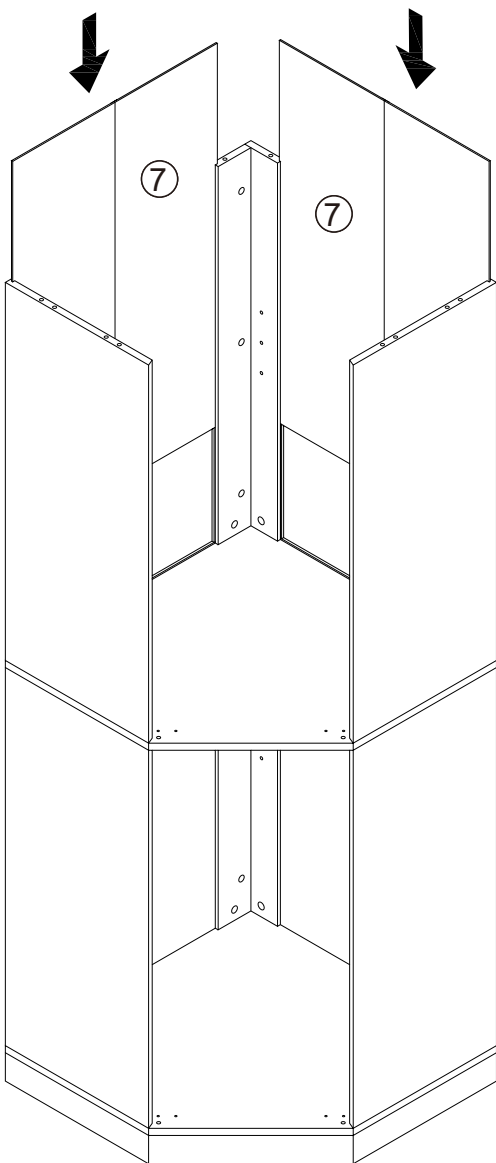

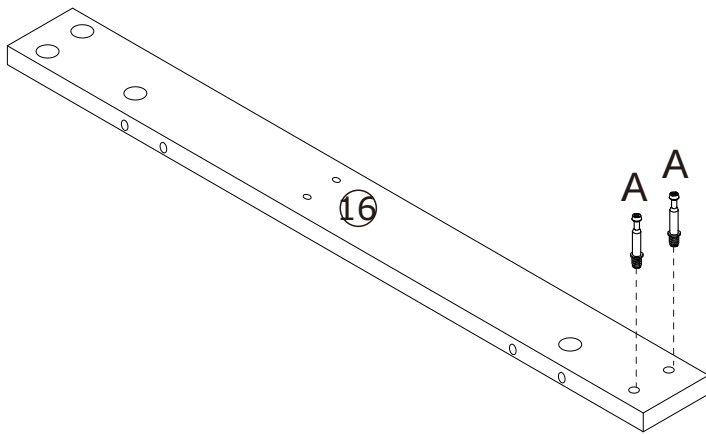
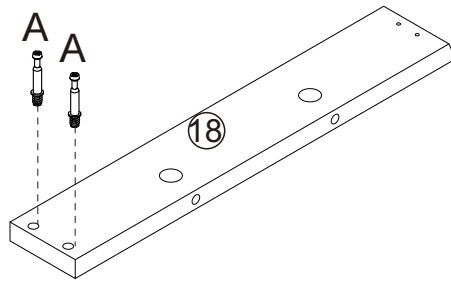
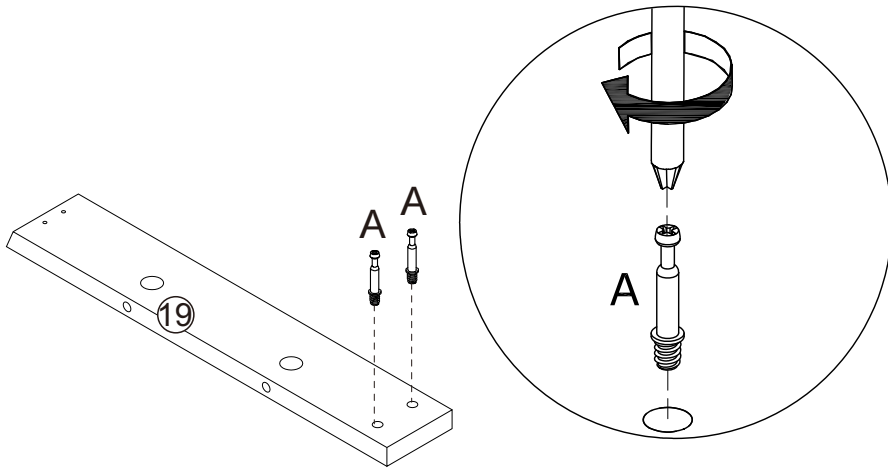
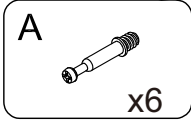

9



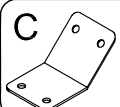

10

B  x6

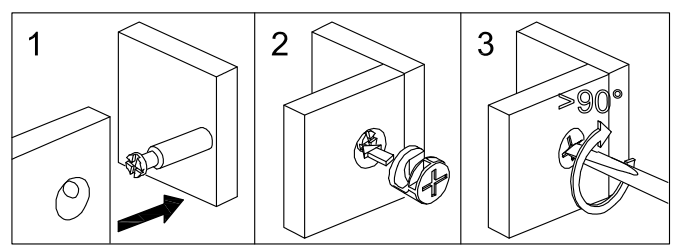
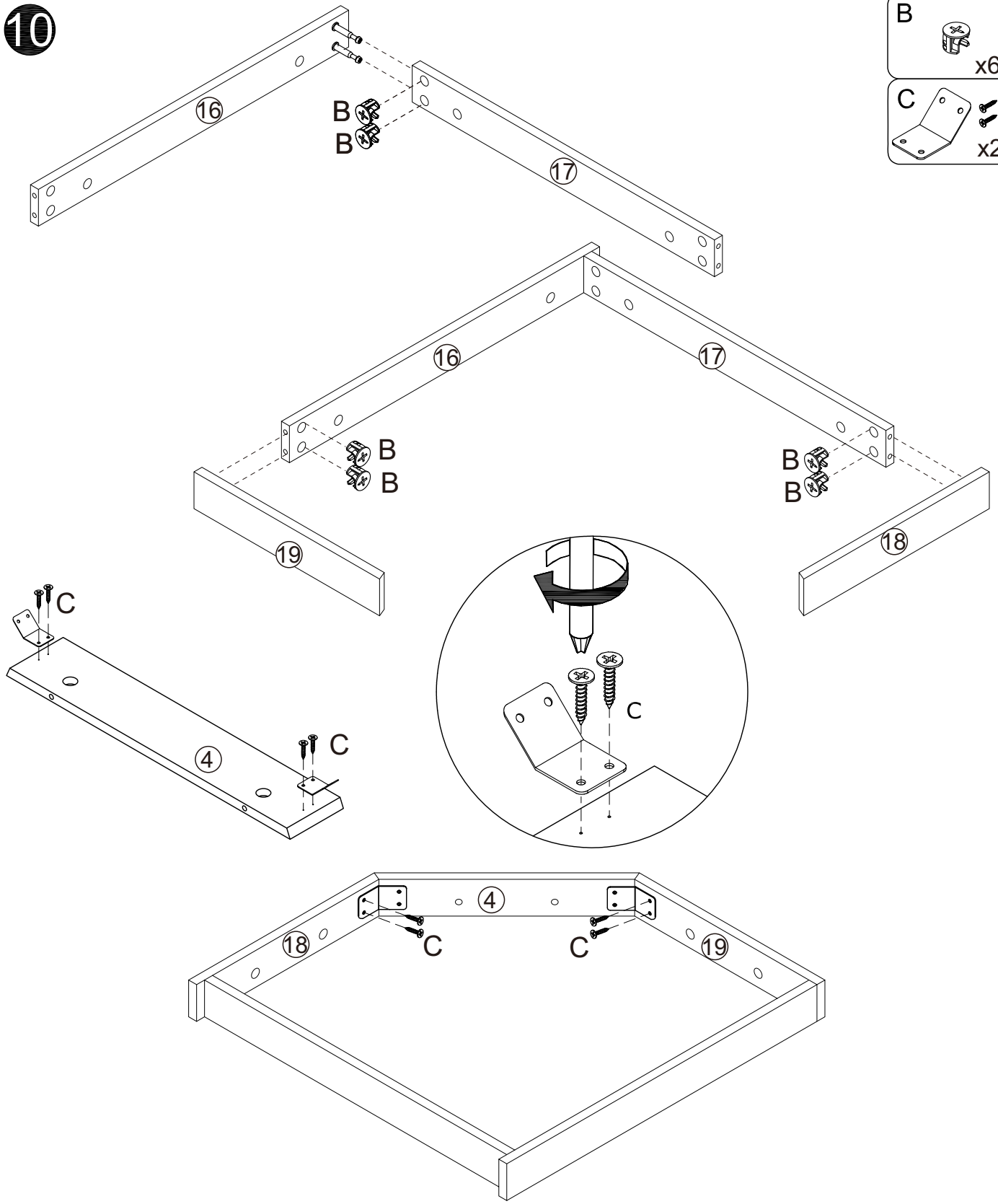
C   x2



11

- A  x10
- B  x10
- L  x4

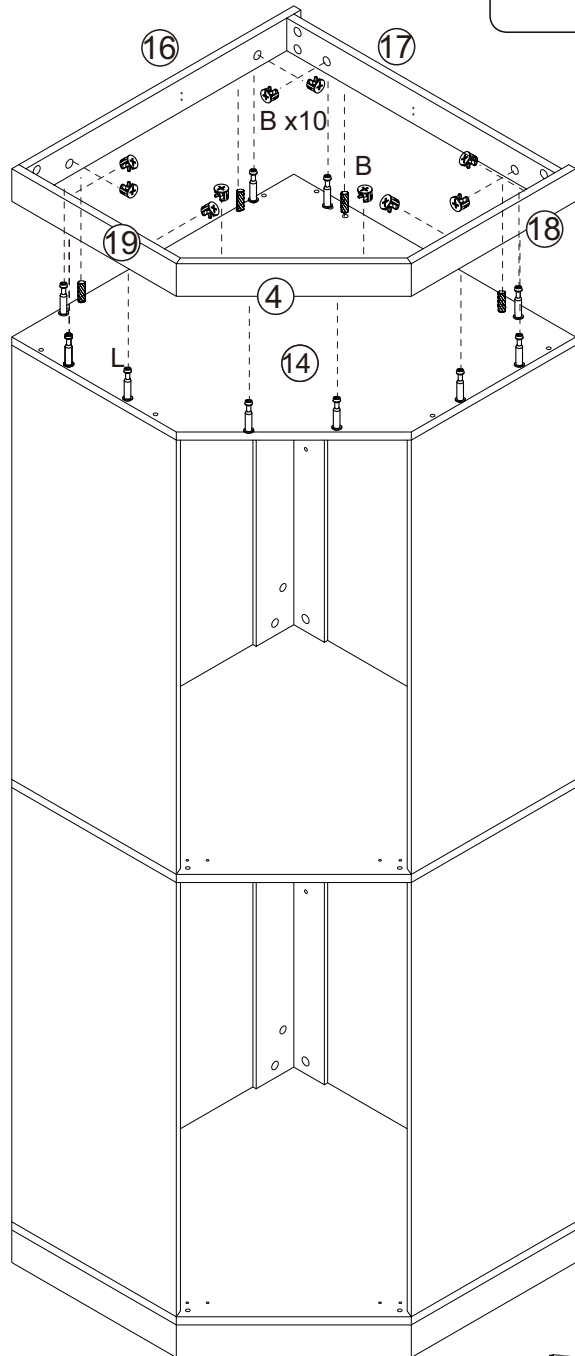
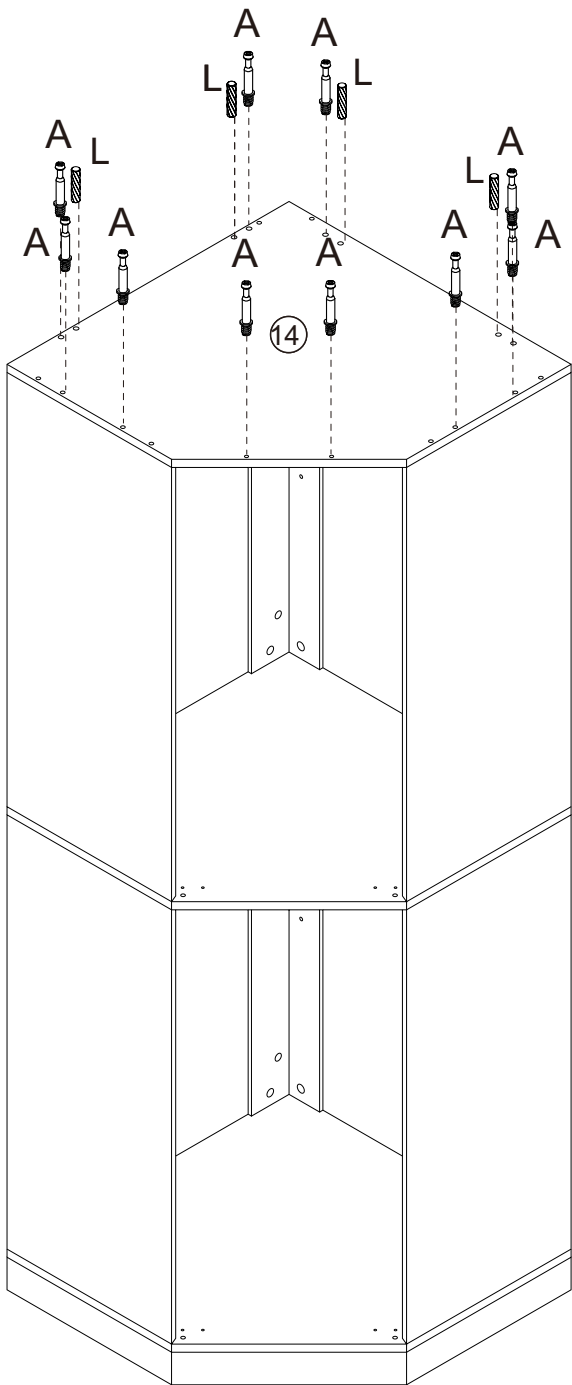

180°



12

F
x10

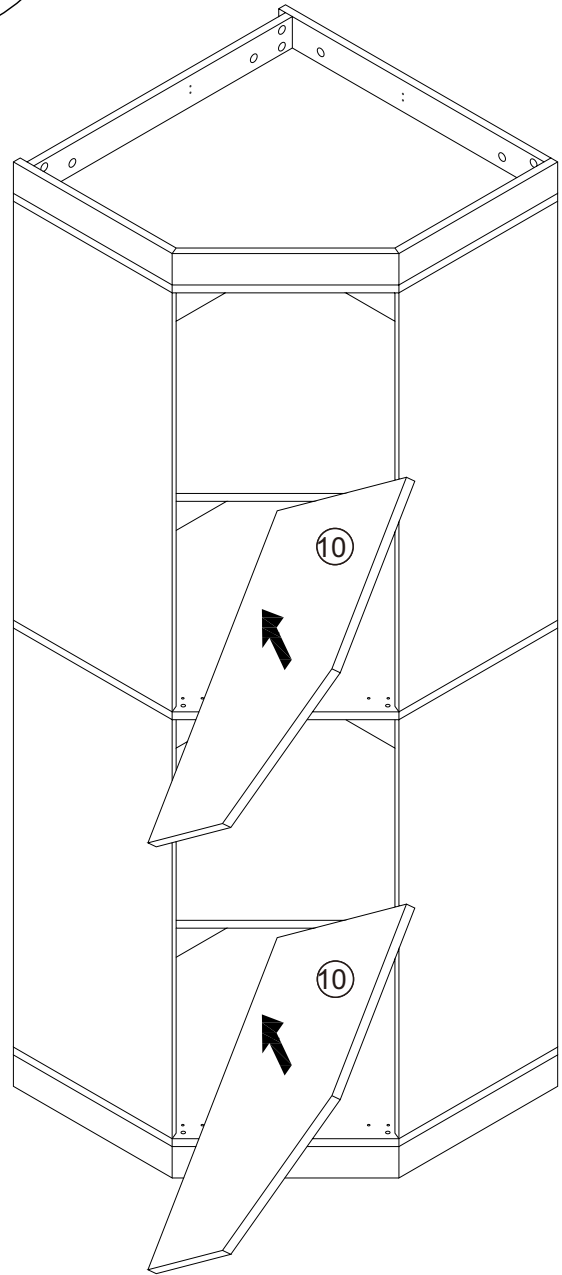
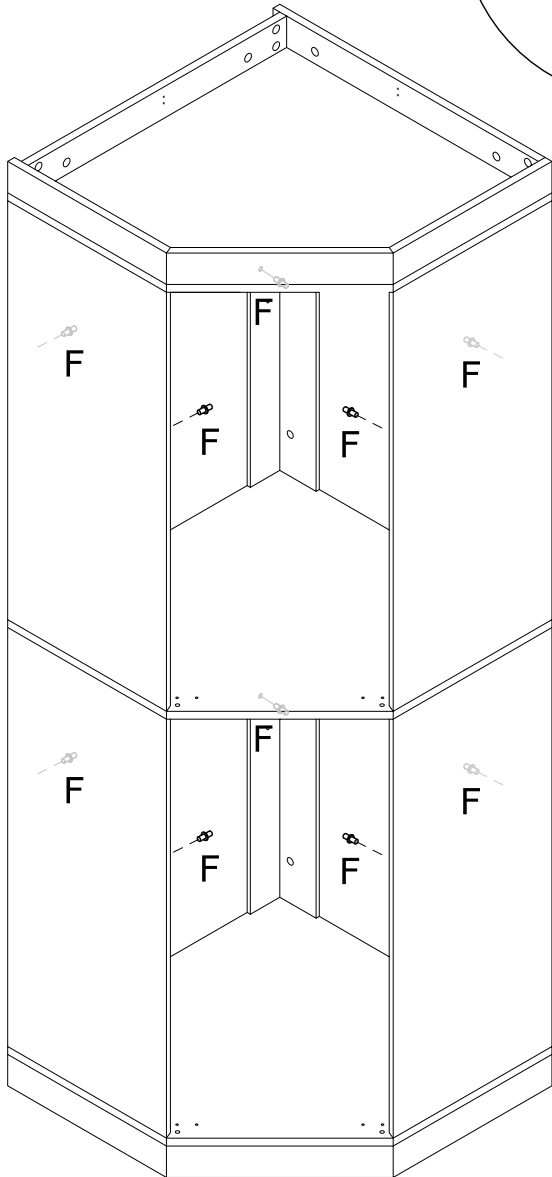
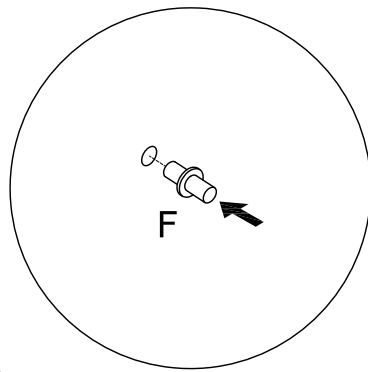

13

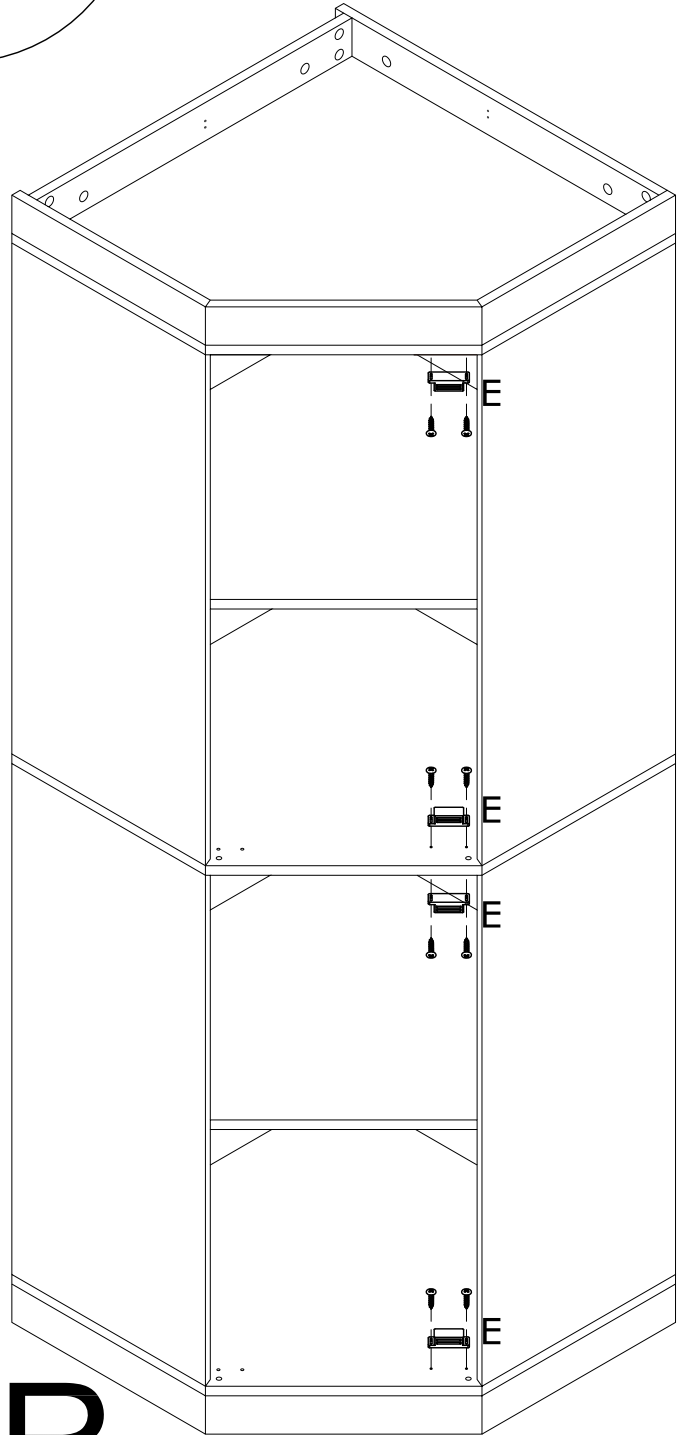
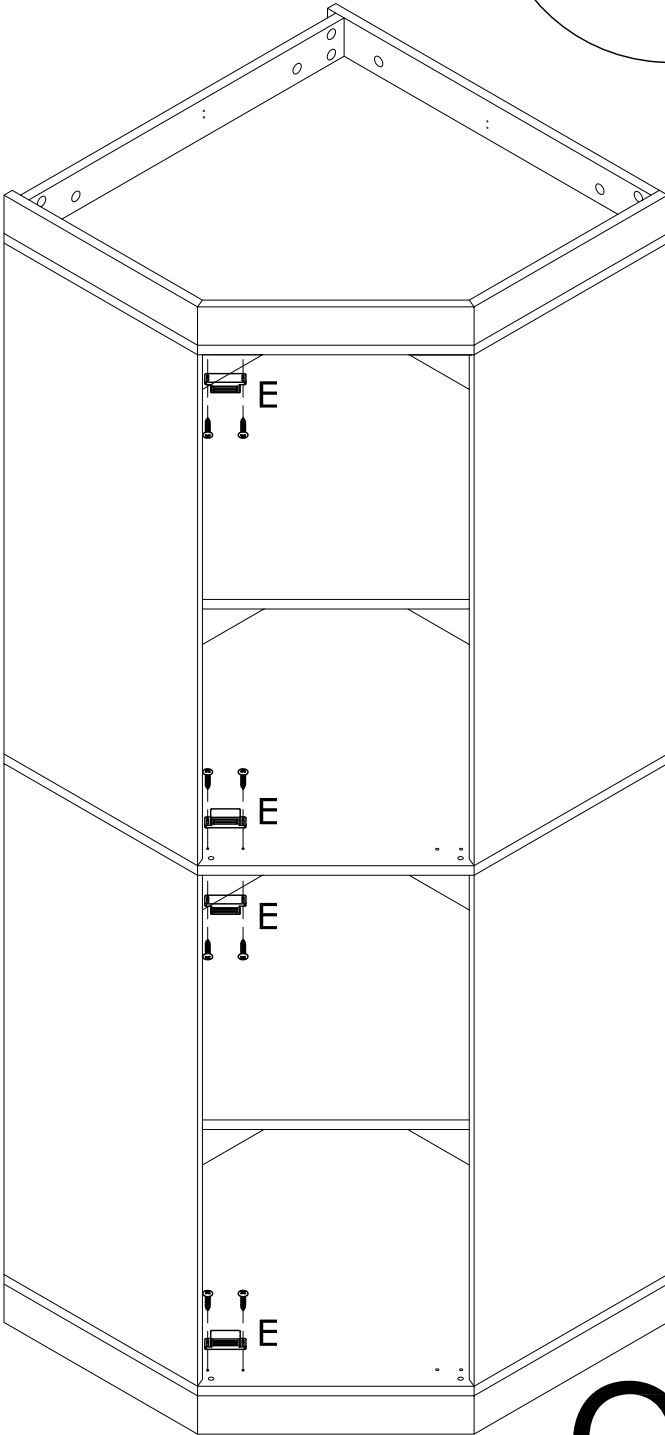
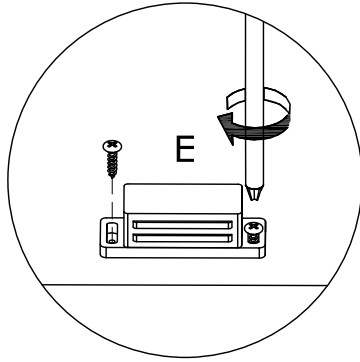
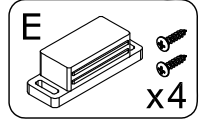

OR

14

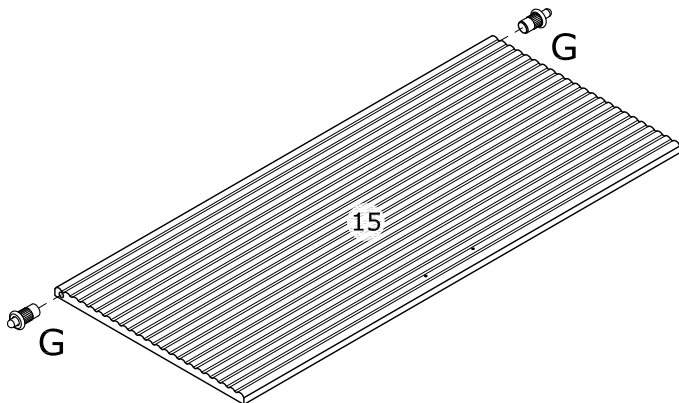
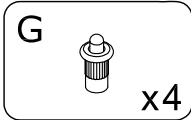

x2

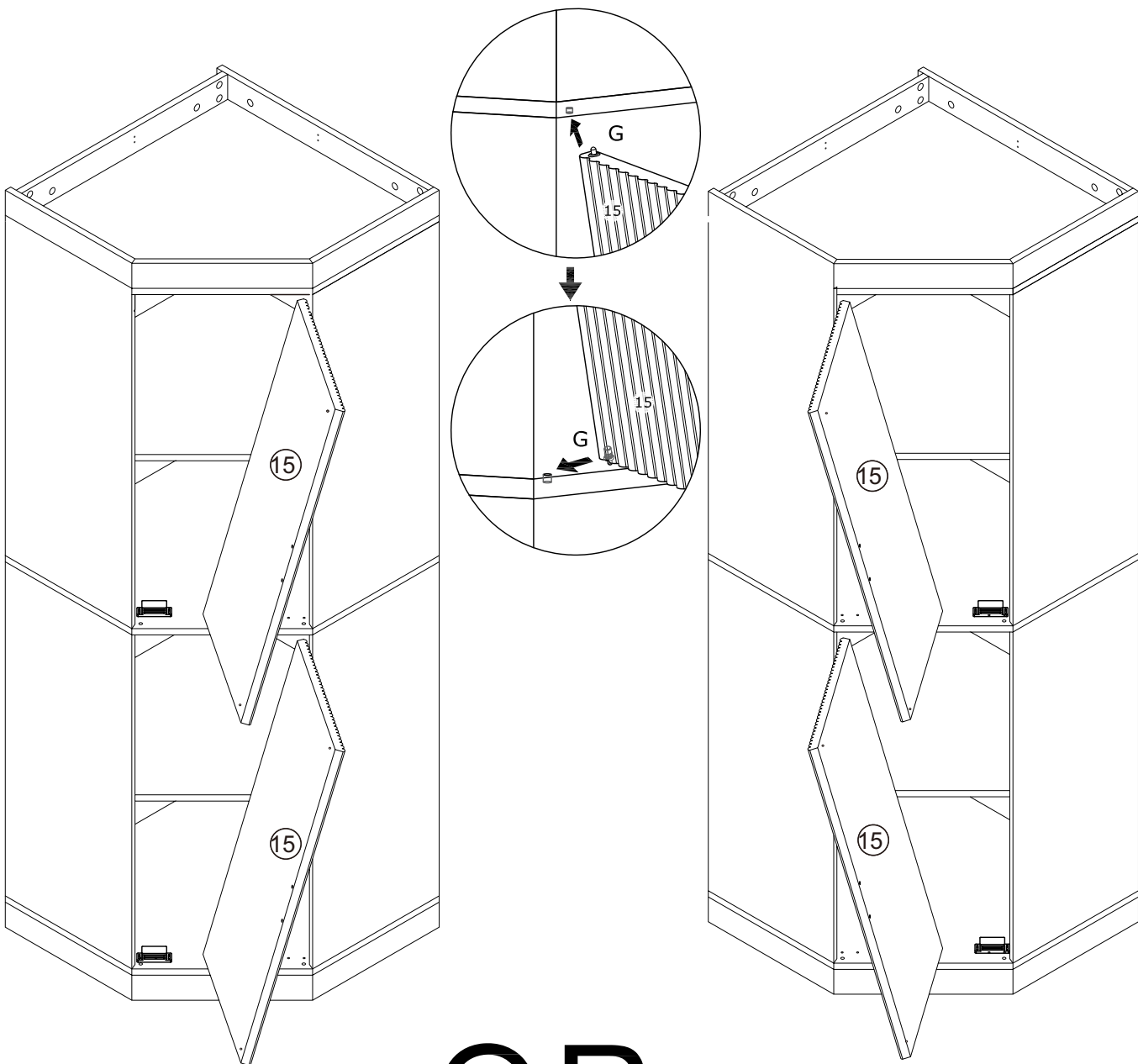

OR

15

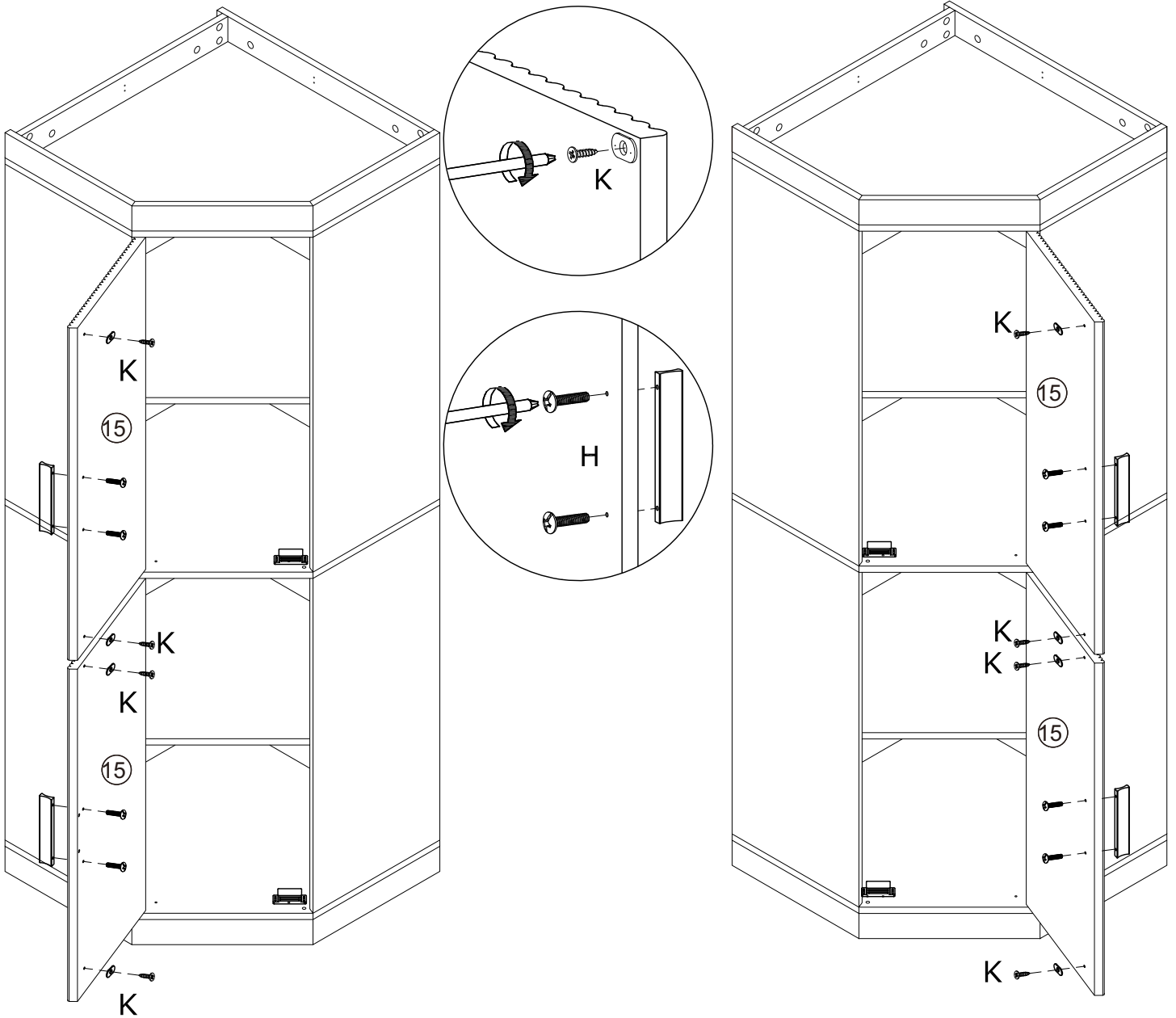
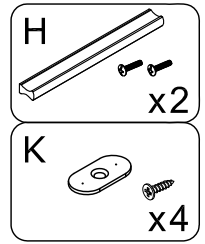

OR

16

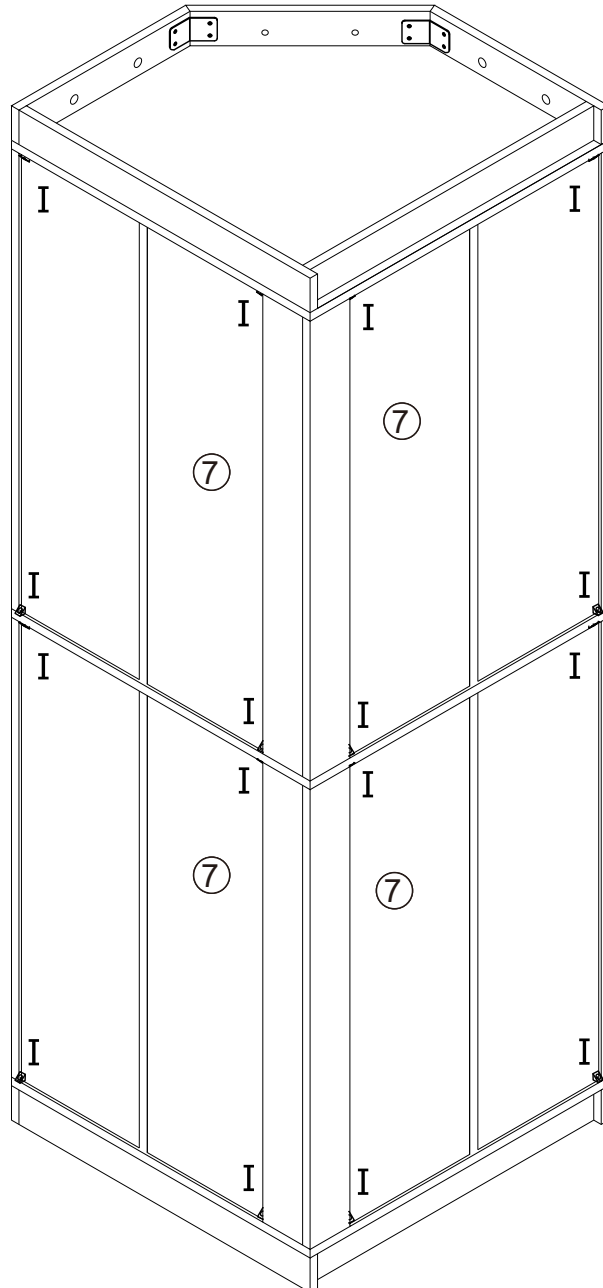
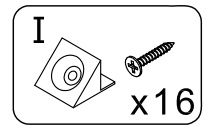
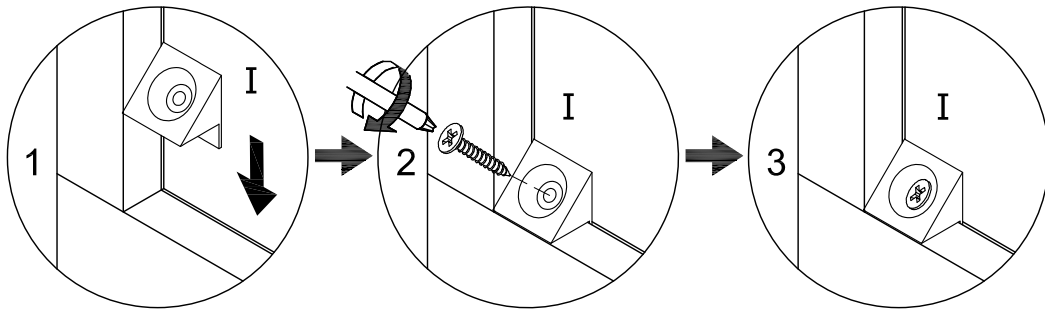

17

