

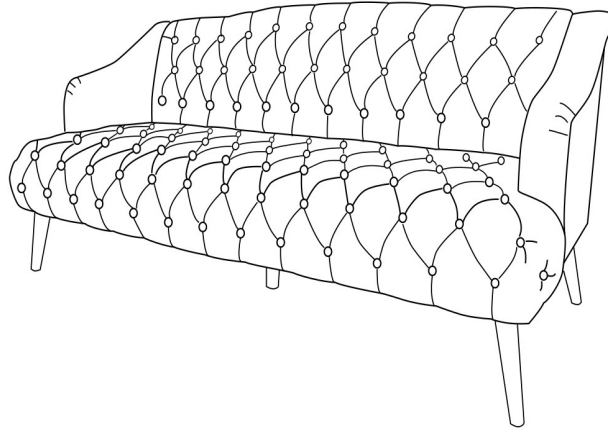



# Assembly Instructions

**Caution: You must read this before you proceed**

## 3 SEATER SOFA

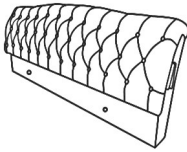
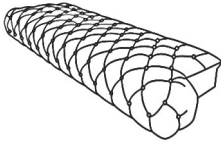





### Parts List

Label	Picture	Description	QTY
A		Backrest Panel	1
B		Seat Base	1
C		Left Side Panel	1
D		Right Side Panel	1
E		Leg	4

F		Middle Leg	1
---	---	------------	---





**Hardware**

Label	Picture	Description	QTY
①		Bolt	7
②		Flat Washer	7
③		Spring Washer	7
④		Plastic Washer	8
⑤		Allen Key	1

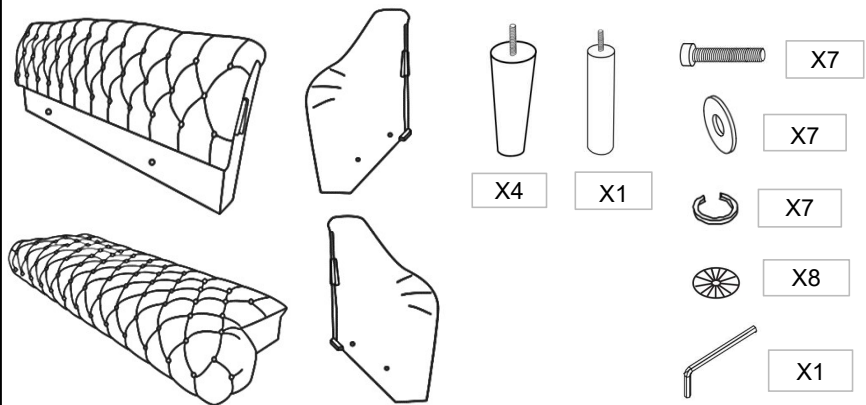
**Assembly Preparation**

Before Beginning Assembly:



-  • Read instructions, cover to cover-
-  • Have 2 adults on hand for assembly-
-  • Do not assemble on flooring or carpet-
-  • Assemble on a clean non-marring surface (packing foam)-
-  • Save all packaging until finished-

# Assembly Steps

## Overview

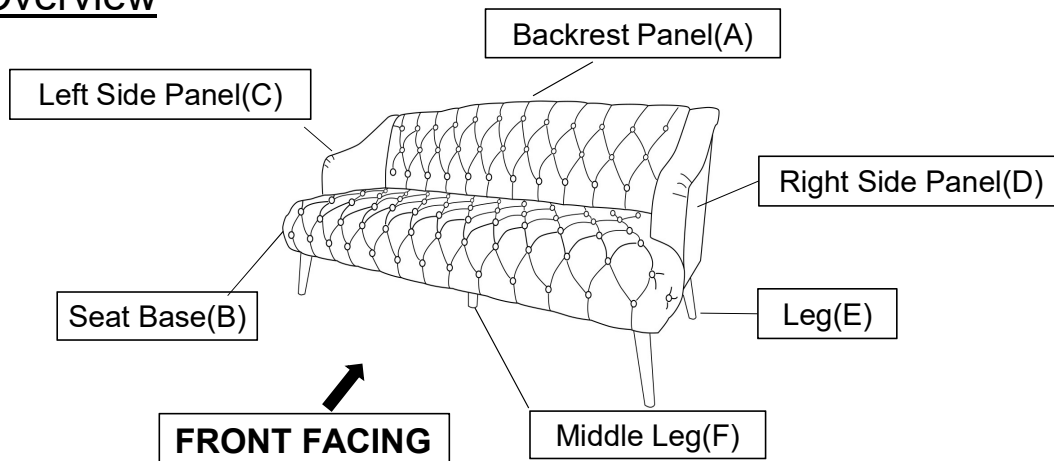

This 3 SEATER SOFA has multiple parts and may require up to 30 minutes to assemble. To give you an overview of the Loveseat parts, the above picture is to help you put the various parts into perspective. Please read through the instructions below to familiarise yourself with the parts and steps before assembly.

## Step 1

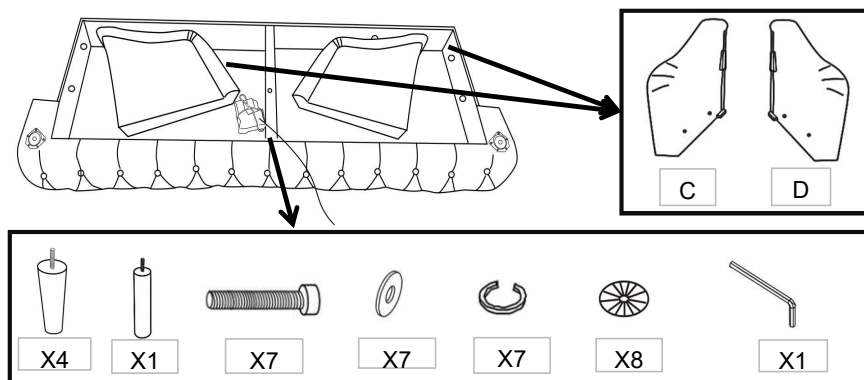

With Assistance from your adult partner, position the Seat Base(B) facedown on a clean, non-marring surface, as shown. Upzip the pouch and remove the Left&Right Side Panel(C)&(D) and Hardware package. Then close the pouch.

## Step 2

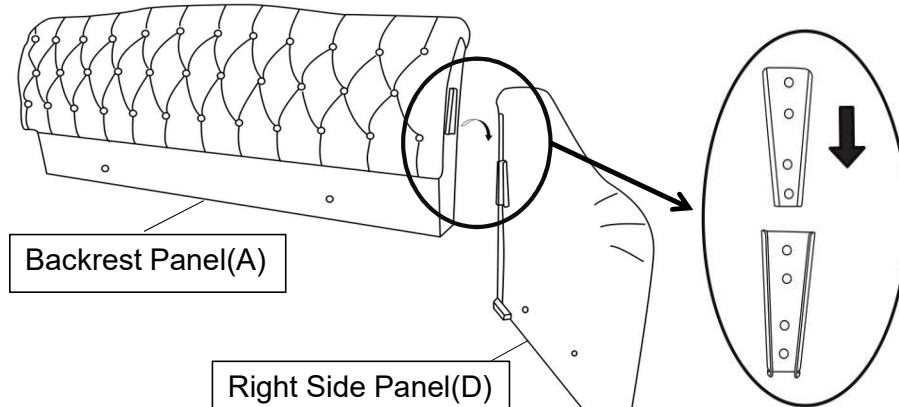

With assistance from your adult partner, lift the Right Side Panel(D) and insert the Connectors on the Right Side Panel(D) into the Connectors on the Backrest Panel(A).

Push firmly down on Right Side Panel(D) to ensure it is fully locked into position.

Repeat the same step to attach the Left Side Panel(C) to Backrest Panel(A).

### Step 3

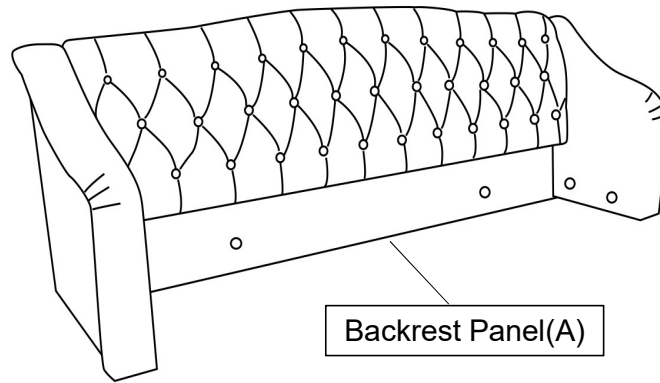

Stand the Backrest Panel(A) up as shown.

### Step 4

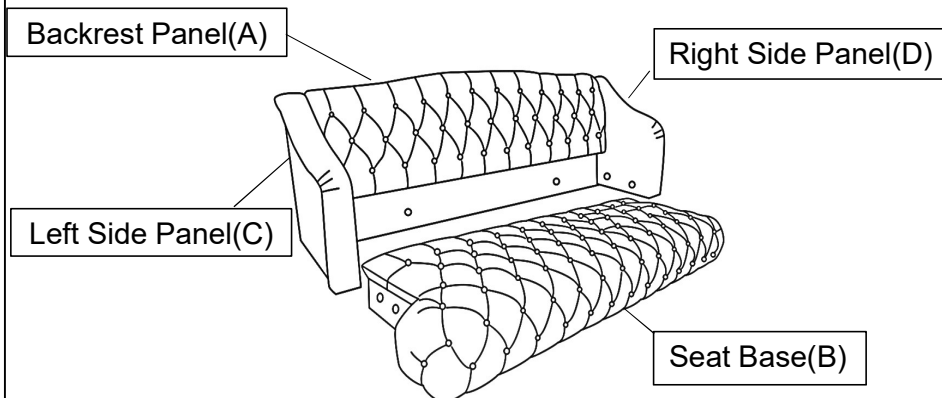

Attach the Seat Base(B) to the Backrest Panel(A) as shown above.

### Step 5

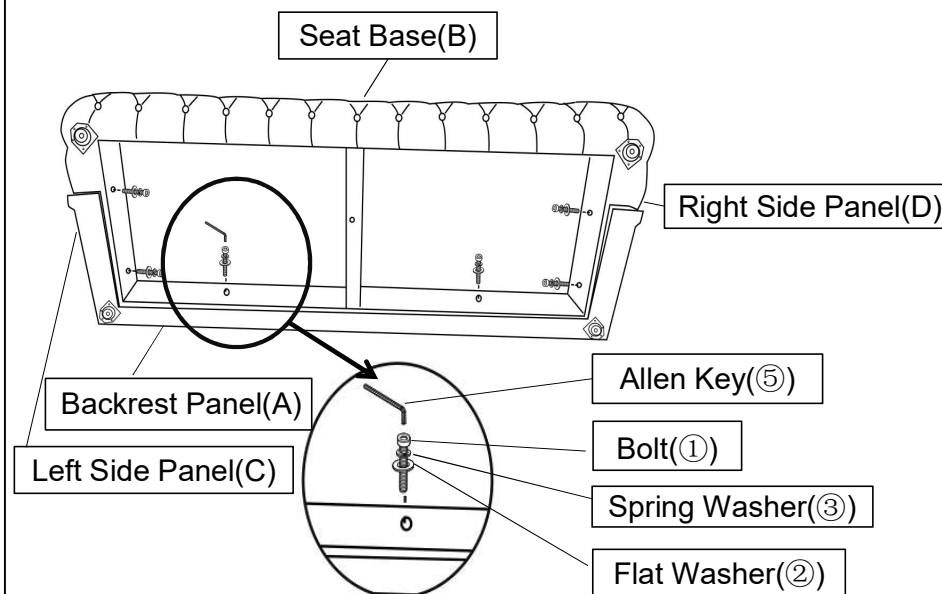

Align the mounting positions of the Seat Base(B) onto the Backrest Panel(A), Left Side Panel(C), Right Side Panel(D), and attach them with Bolts (①), Flat Washer(②), Spring Washer(③) with Allen Key(⑤). Tighten all the bolts by Allen Key(⑤).

### Step 6

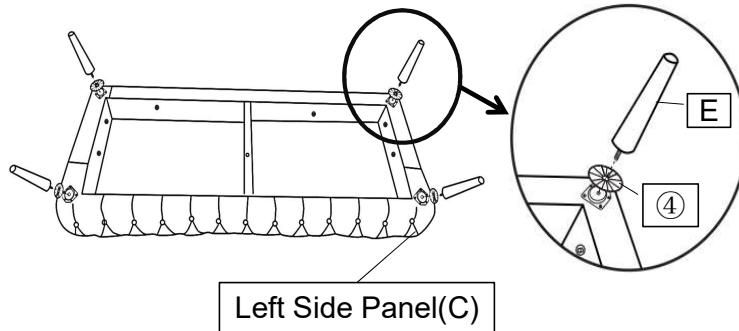

Install the Leg(E) into the bottom of the Left Side Panel(C) by placing one Plastic Washer(④) and tighten by turning the leg clockwise. Repeat the same step to install the remaining three legs(E). **Do not fully tighten the Legs.**

### Step 7

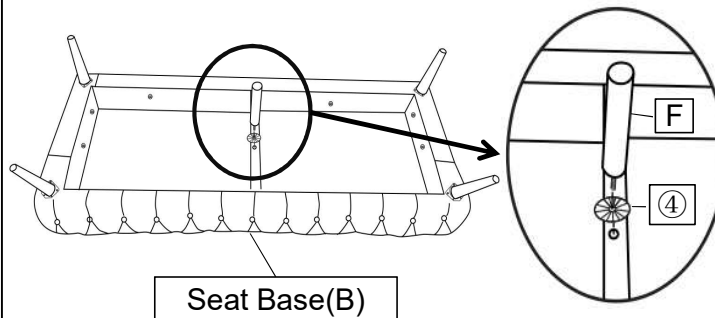

Install the Middle Leg(F) into the bottom of the Seat Base(B) by placing one Plastic Washer(④) and tighten by turning the leg clockwise. **DO NOT OVER TIGHTEN.**

### Step 8

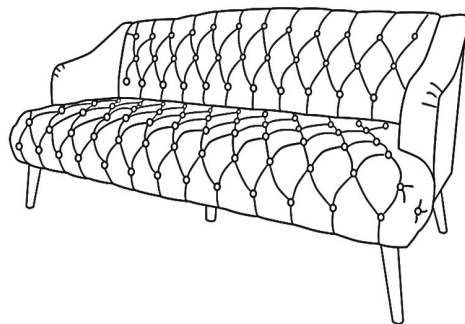





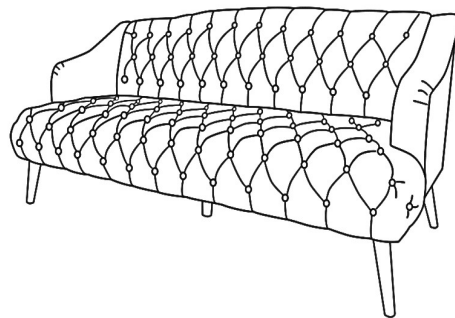

























Stand the Sofa up.  
 Place the Sofa on a LEVEL SURFACE.  
 Inspect it and make sure all parts are adequately connected.  
 Gently and carefully, sit on the Sofa.  
 This pressure will help the Legs and Seat Base reach full alignment status.  
 Then get off the Sofa and carefully place the Sofa facedown.  
**Then proceed to tighten all Bolts at all joints in a sequential manner.  
 If there are still wobbles, loosen the Bolts and execute the same process.**

**Step 9**



Your 3 Seater Sofa is ready for use.  
 This 3 Seater Sofa can only be used on a flat, level surface.

**Care & Maintenance**

- 

 Do not put hot items directly on furniture surface
  - 

 Do not clean furniture with harsh cleansers or polish.
  - 

 Do not place furniture under direct sunlight.
  - 

 Do not place furniture near heating or cooling vents.
  - 

 Do not write on furniture without a padded barrier to protect the surface.
  - 

 Do not place furniture outside . For indoor use only .
  - 

 Not for commercial use. For residential use only .
  - 

 Stains may be removed with mild soap solution and damp cloth.
  - 

 Children should not climb or jump on the furniture.
- 
- 

 Dust and pick-up spills using a clean, non-colored, lint-free cloth .