

# **INSTRUCTION MANUAL**

## **Caning Dining Chair**

IF YOU PURCHASED THE CHAIR ONLINE AND HAVE ANY  
QUESTIONS OR CONCERNS  
PLEASE CONTACT US WITH EMAIL OR TEXT

**Email: [hiwarrantyservice@outlook.com](mailto:hiwarrantyservice@outlook.com)**  
**TEXT: +1 628-263-4608**

### **WARNING:**

Proper use of the chair is for single person seating only. The chair is not to be used for standing purposes and will not function as a stool or stepladder. Use on even surfaces only. Chair tested for use at weight of 250lb (113.4kg). Improper use of this product or failure to use as directed may result in injury. Not intended for commercial use.

### **IMPORTANT:**

Please read all the instructions and warnings before assembling. In order to make the whole product adjust to the best, please install all the screws on the product before fully tighten.

### **SAFETY INFORMATION:**









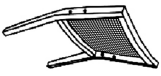

- Keep all children and pets away from assembly area. Children and pets should be supervised when they are in the area of the product construction.
- Keep assembly area at least 6 feet from any obstruction such as a fence, garage, house, overhanging branches, laundry line or electrical wires.
- Some parts may contain sharp edges. When assembling and using this product, basic safety precautions should always be followed to reduce the risk of personal injury and damage to the product. Please read all instructions before assembly and use.
- Check all bolts for tightness before use. **IMPORTANT** - check and tighten bolts often to keep them secure!
- The chair is not to be used for standing purposes and will not function as a stool or step-ladder. Use on even surfaces only.
- The chair use at wight of 250lb (113.4kg). Improper use of this product or failure to use as directed may result in injury. Not intended for commercial use.

### **CARE & MAINTENANCE:**

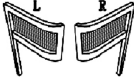
- **SPILLS:** Immediately wipe up the spill using a white damp cloth. Repeat process until stain is gone.
- **RATTAN PRODUCT CARE:** Before using, clean the product completely with a soft dry towel. When not in use, wipe free of any dirt or loose objects, wash with a mild solution of soap and water, rinse thoroughly and dry completely. Do not use strong detergent or abrasive cleaners. Over time nuts and bolts can loosen. Occasionally, check nuts and bolts on all chairs and tables, re-tighten if necessary.

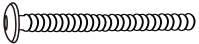
To prolong the life of the product, do not use it in a humid environment or outdoors and avoid placing it in direct sunlight or too close to heat sources.

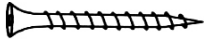
## Parts List

A		1PC	F		4PCS
B		1PC	G		4PCS
C		1SET	H		1PC
D		10PCS	I		1PC
E		2PCS	J		1PC

## Operating Instructions

**Step 1 :** Assemble the left/right armrest C to chair back A by using screw D . Don't fully tighten bolts at this step .

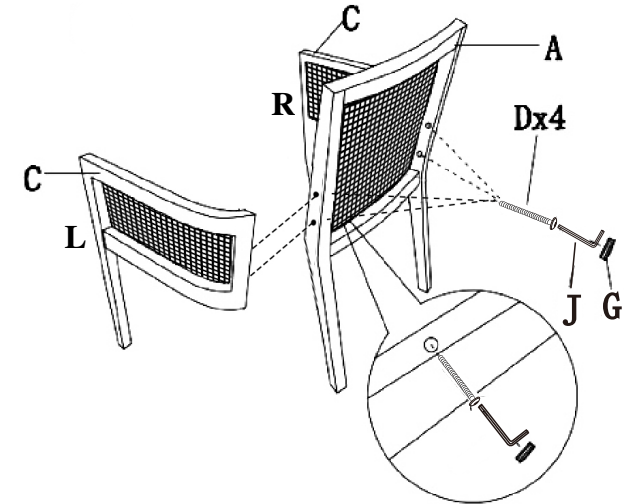

**Step 2 :** Put the dowel pin into the middle hole of chair back A as below shown , then insert chair base B to align for connection

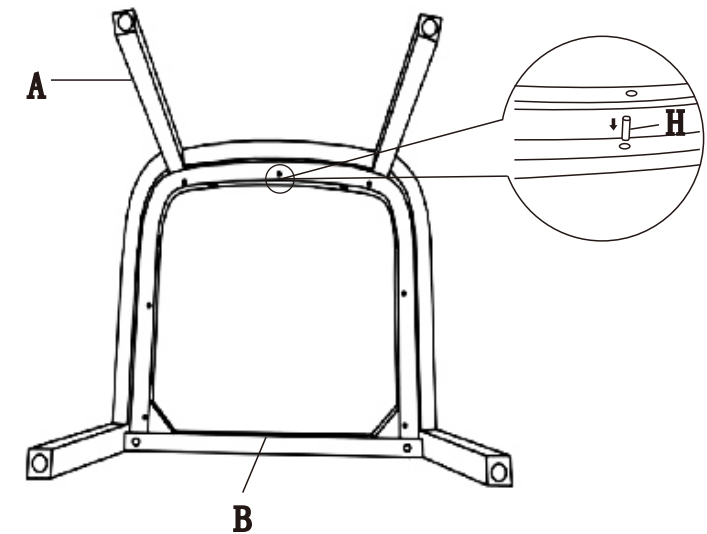

**Step 3 :** Assemble chair B using screw D and attach foot pat F .  
You can fully tighten all the bolts now .

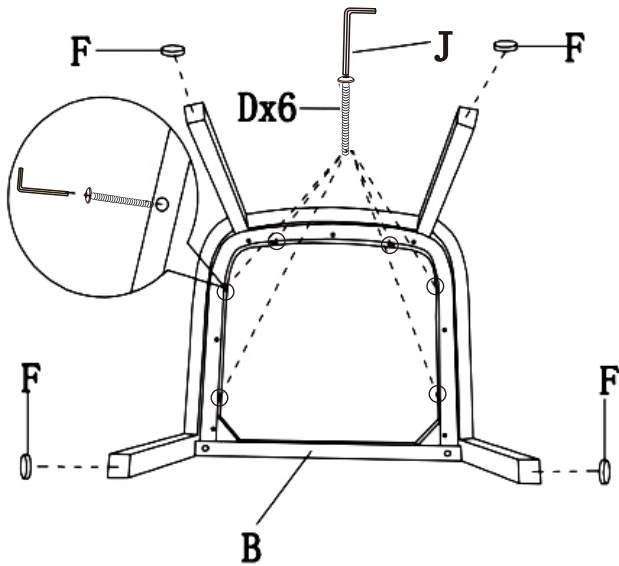

**Step 4 :** Fasten and secure the base by using the tapping screw E .

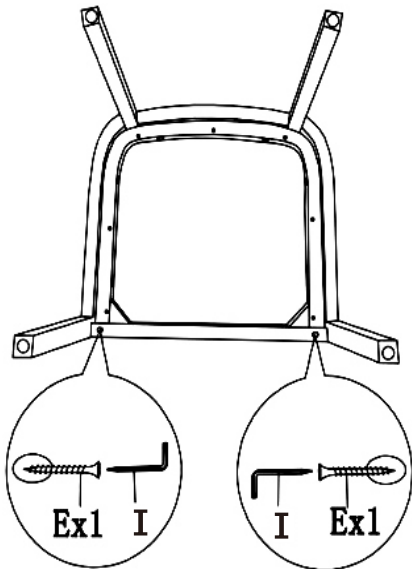

**Step 5 :** Now the Caning chair is fully assembled and ready to use !

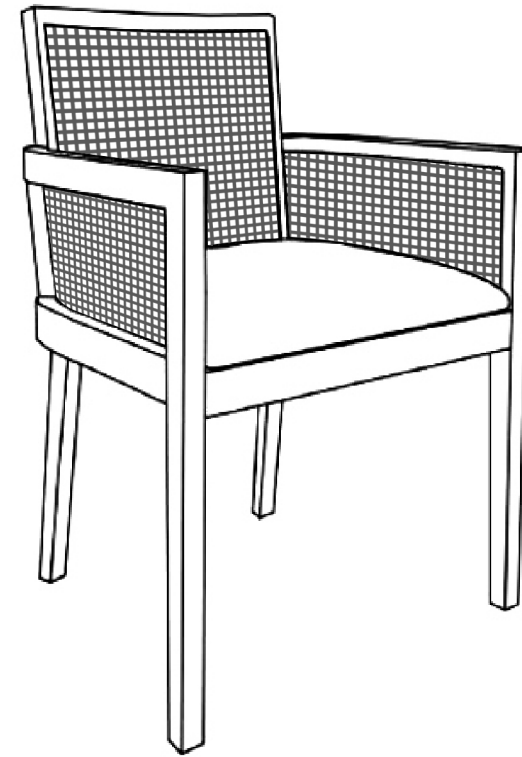

IF YOU PURCHASED THE CHAIR ONLINE  
AND HAVE ANY QUESTIONS OR CONCERNS  
PLEASE CONTACT US WITH EMAIL OR TEXT

EMAIL: [hiwarrantyservice@outlook.com](mailto:hiwarrantyservice@outlook.com)  
TEXT : +1 628-263-4608