

# CHAIR & TABLE COMPANY

## ASSEMBLY INSTRUCTION

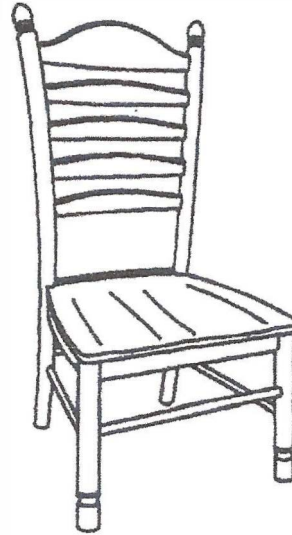

### PARTS LIST

1 CHAIR BACK FRAME	1 PC
2 SEAT	1 PC
3 FRONT LEG (RIGHT)	1 PC
4 FRONT LEG (LEFT)	1 PC
5 FRONT STRETCHER	1 PC
6 SIDE STRETCHER	2 PCS

### HARDWARE LIST

A	JCBC SCREW M6 x 40MM	3 PCS
B	JCBC SCREW M6 x 60MM	4 PCS
C	JCBC SCREW M6 x 70MM	4 PCS
D	SPRING WASHER 1/4"	11 PCS
E	FLAT WASHER 1/4" x 19MM	11 PCS
F	M4 ALLEN KEY (BALL SHAPE) LONG	1 PCS
G	PAN HEAD SCREW M4 x 38MM	6 PCS

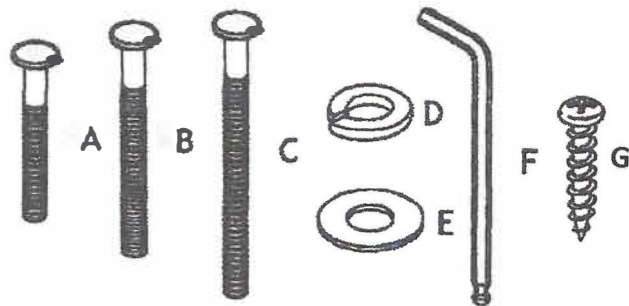
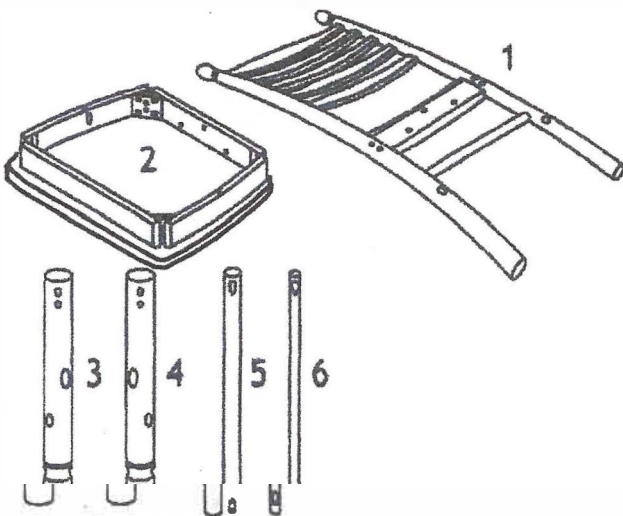

### TOOLS REQUIRED (NOT INCLUDED) :



Phillips Head Screw Driver

### **IMPORTANT NOTE :**

- Place all wooden parts on a clean and smooth surface such as a rug or carpet to avoid the parts from being scratched. Check to be sure that you have all parts and hardware. Remove all wrapping materials, including staples & packing straps before you start to assemble.
- Keep all hardware parts out of reach of children.
- **DO NOT TIGHTEN BOLTS/SCREWS UNTIL ALL COMPLETELY ASSEMBLED.**

# ASSEMBLY INSTRUCTION

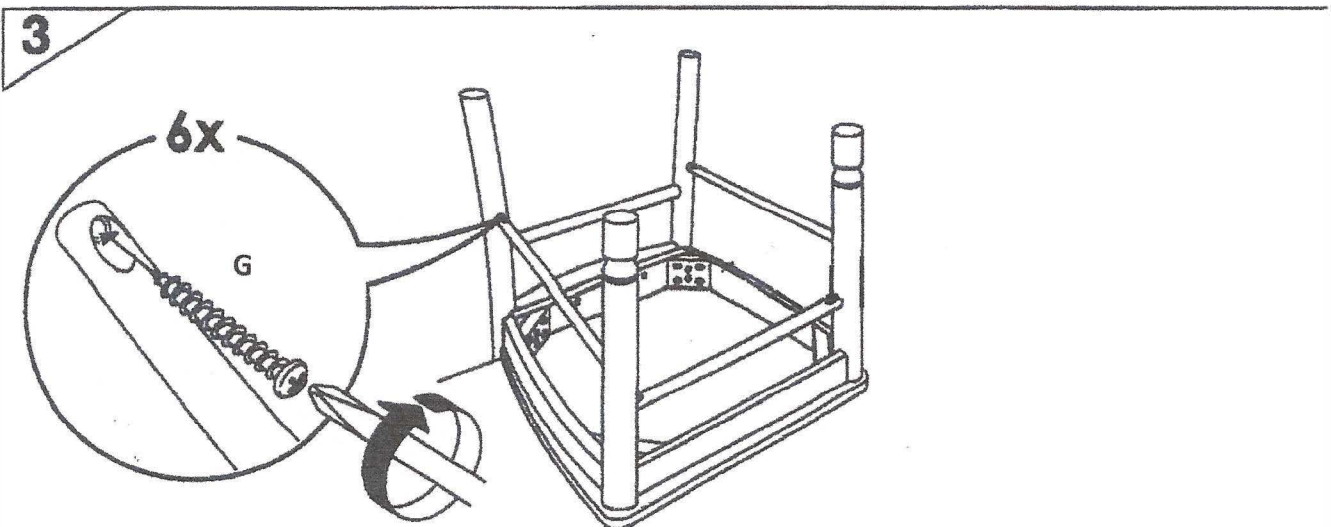
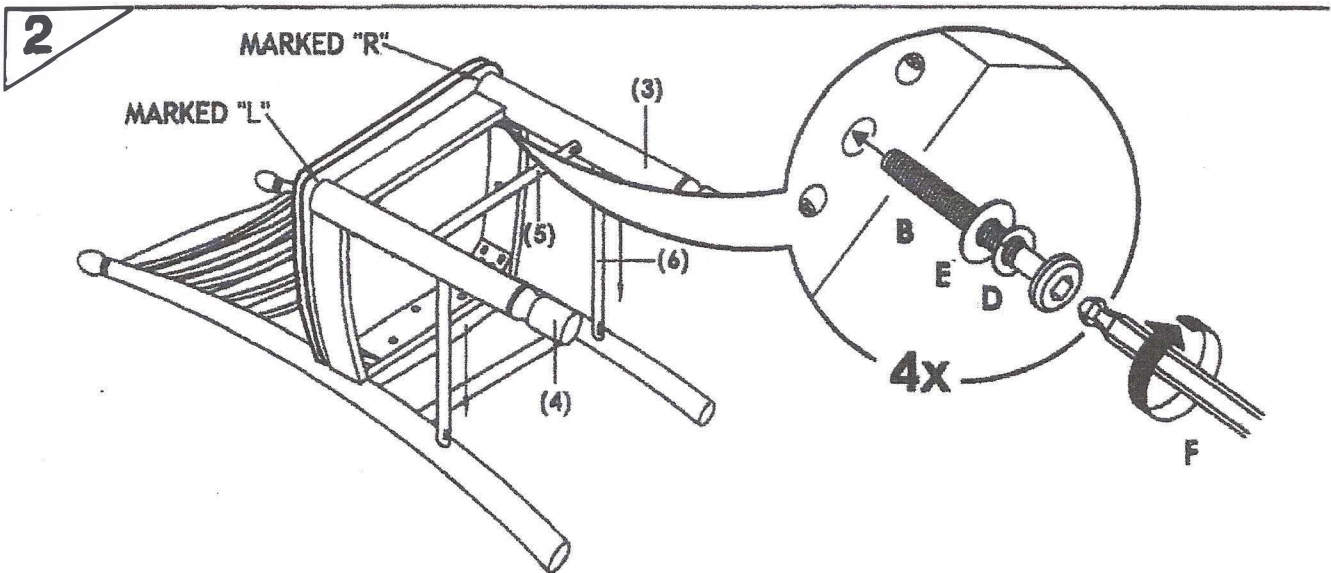
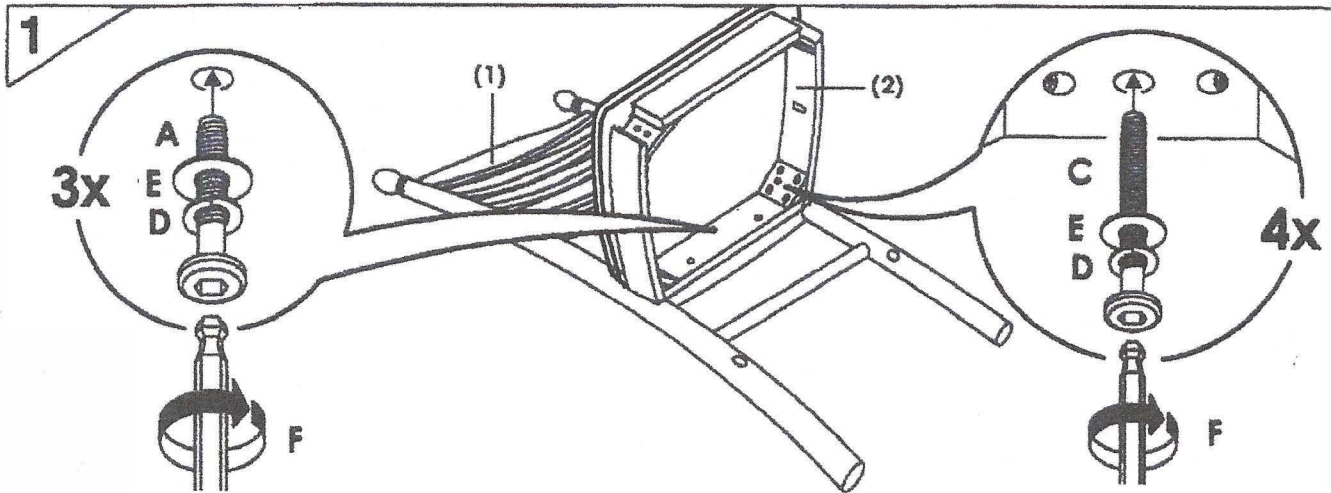

## CARE AND MAINTENANCE !

- The touch of a soft cloth is all the maintenance your wood pieces will ever need. Never use harsh chemicals or abrasive cleaners, as they could mark or destroy finish.