

## Recommended Maximum Weight

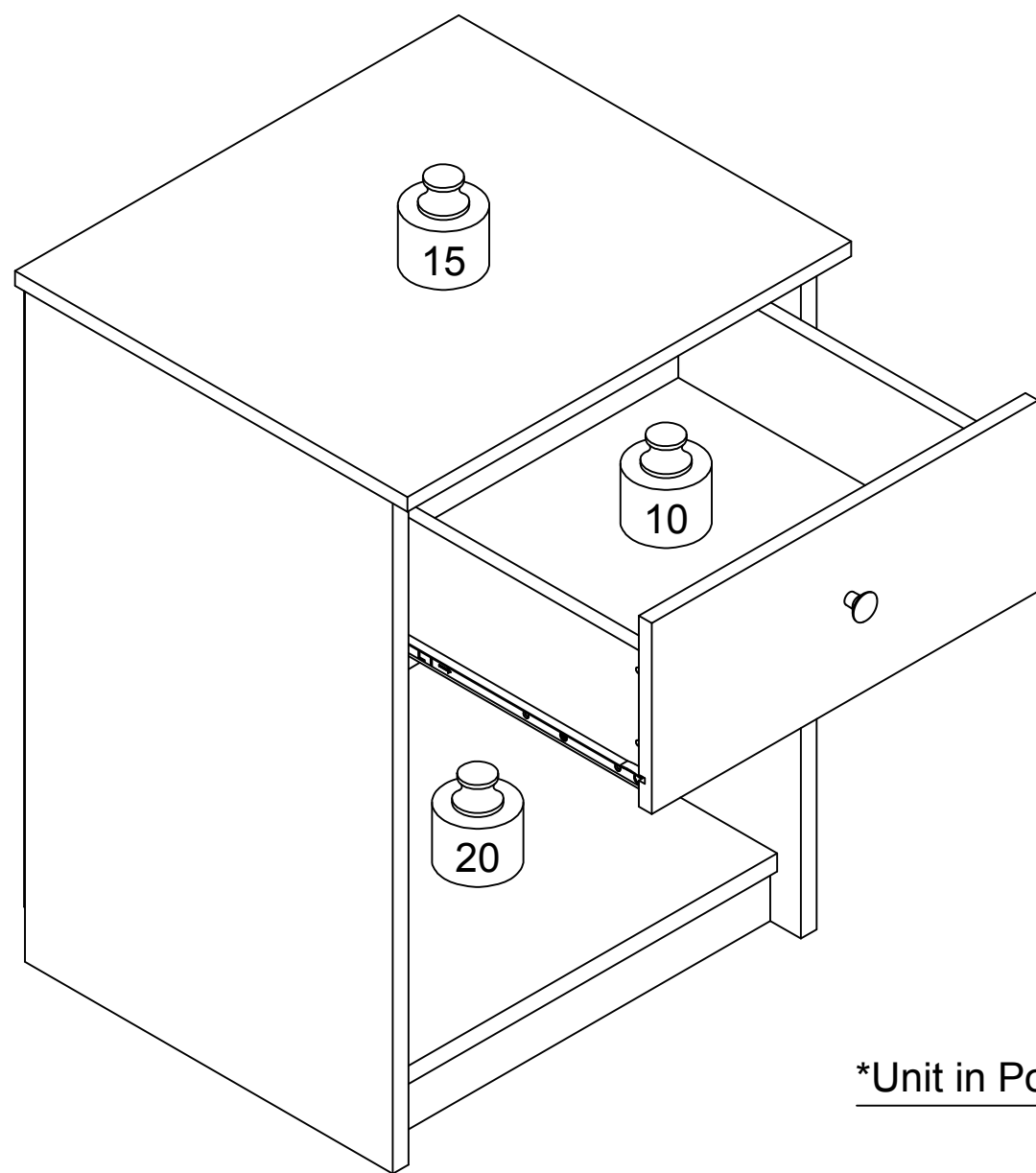

\*Unit in Pound(lbs.)

### **WARNING:**

>This unit has been designed to support the maximum loads shown. Exceeding these load limits could cause sagging, instability, product collapse, and/or serious injury.

>DO NOT allow children to climb on unit.

> Put heavier items on lower shelves.



## **Assembly Instruction**

Nightstand With One Drawer

00:30

Approx. 30 minutes



Recomm. 1 Person

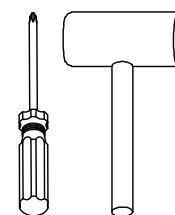

Tool Required

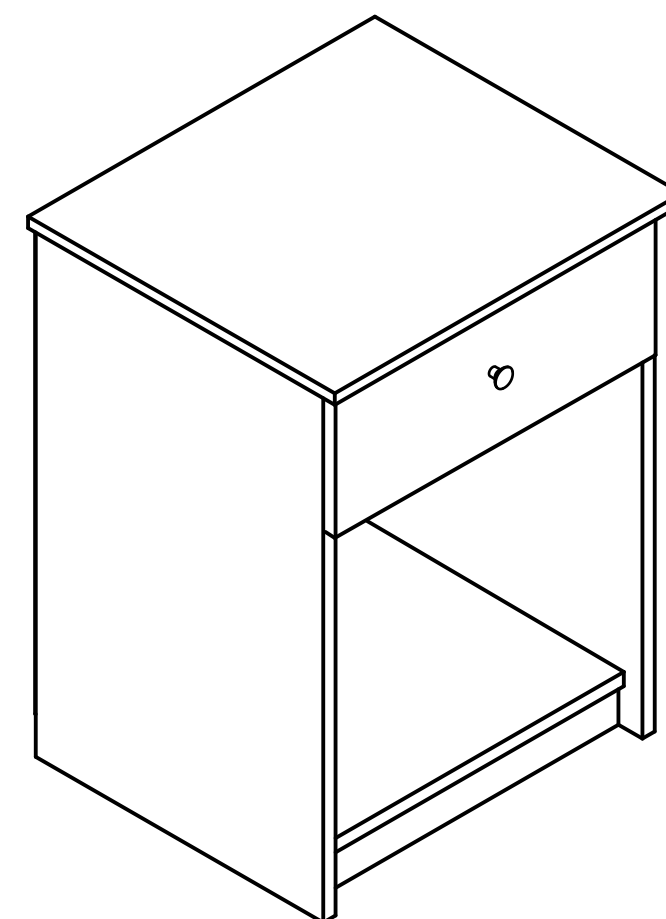

## EXPLODED VIEW

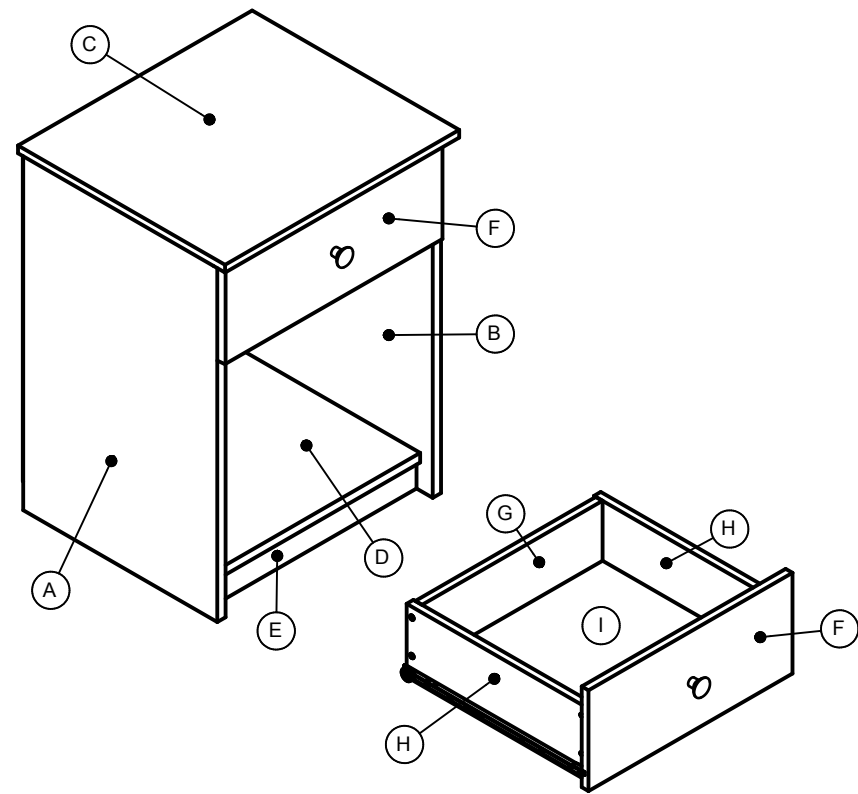

## PARTS LIST

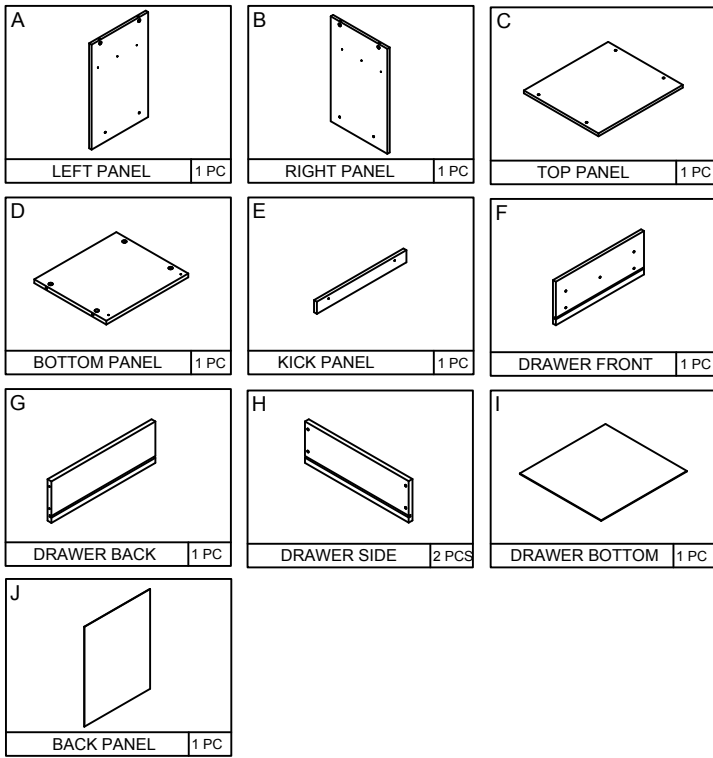

## HARDWARE LIST

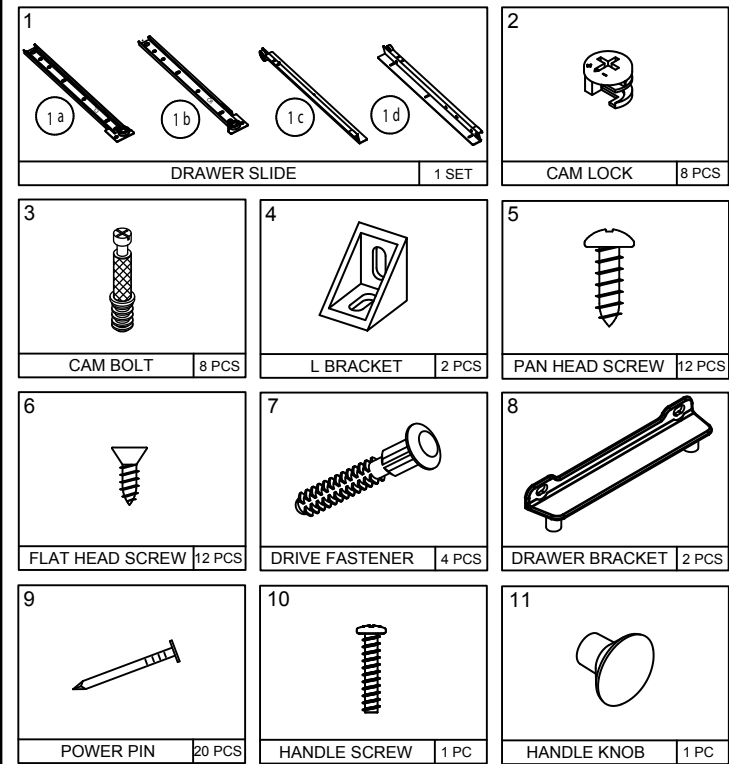

## USEFUL HINTS BEFORE YOU START:

1. Read each step carefully before starting.
2. It is important that each step is performed in correct order to avoid difficulties.
3. Identify, soft and count the parts before assembly.
4. Assemble your furniture on packaging cardboard to prevent scratch or damage.
5. Clean the product with mild cleanser using soft damped cloth. Do not use harsh or abrasive cleanser.
6. Using incompatible hardware might cause damage to product.

## STEP 9

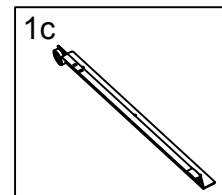

DRAWER SLIDE | 1 PC

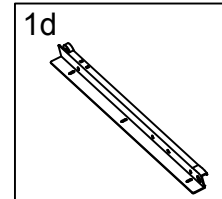

DRAWER SLIDE | 1 PC

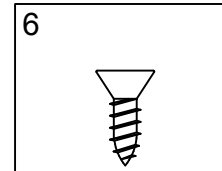

FLAT HEAD SCREW | 6 PCS

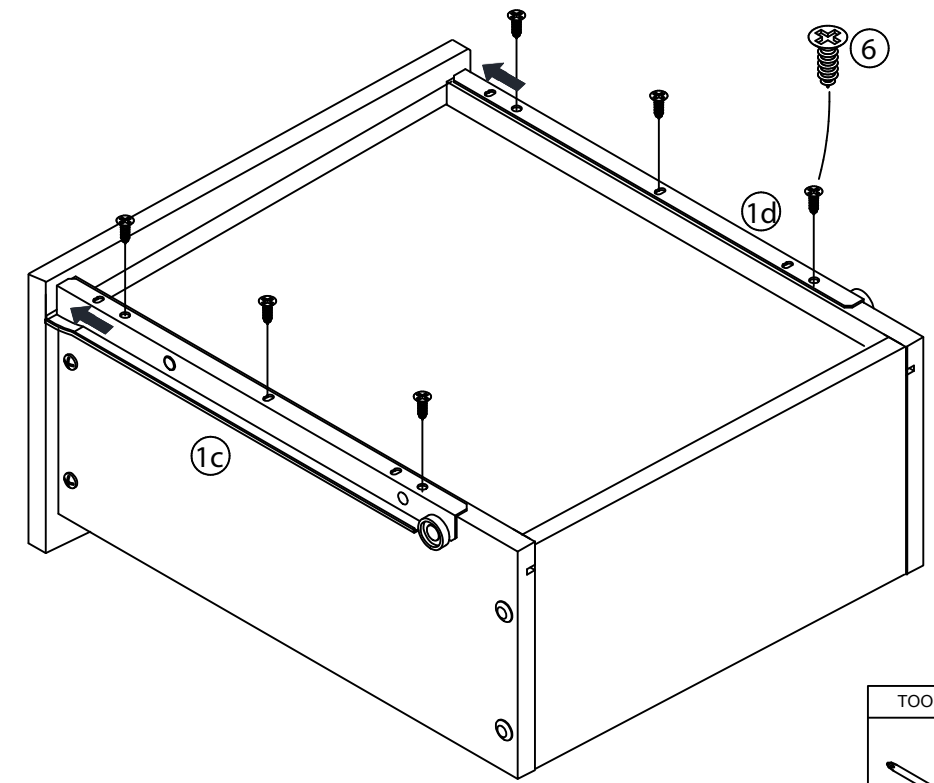

TOOL REQUIRED

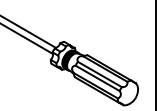

## STEP 10

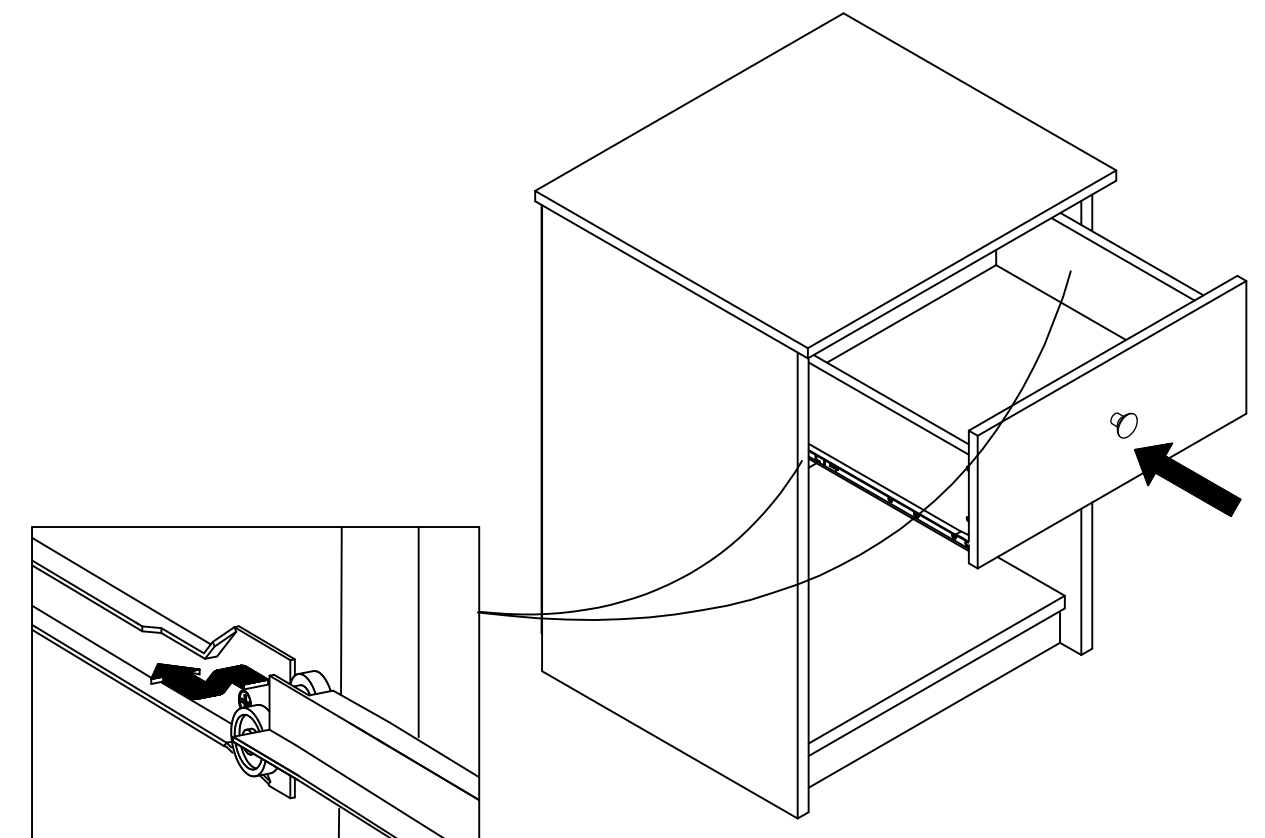

# STEP 7

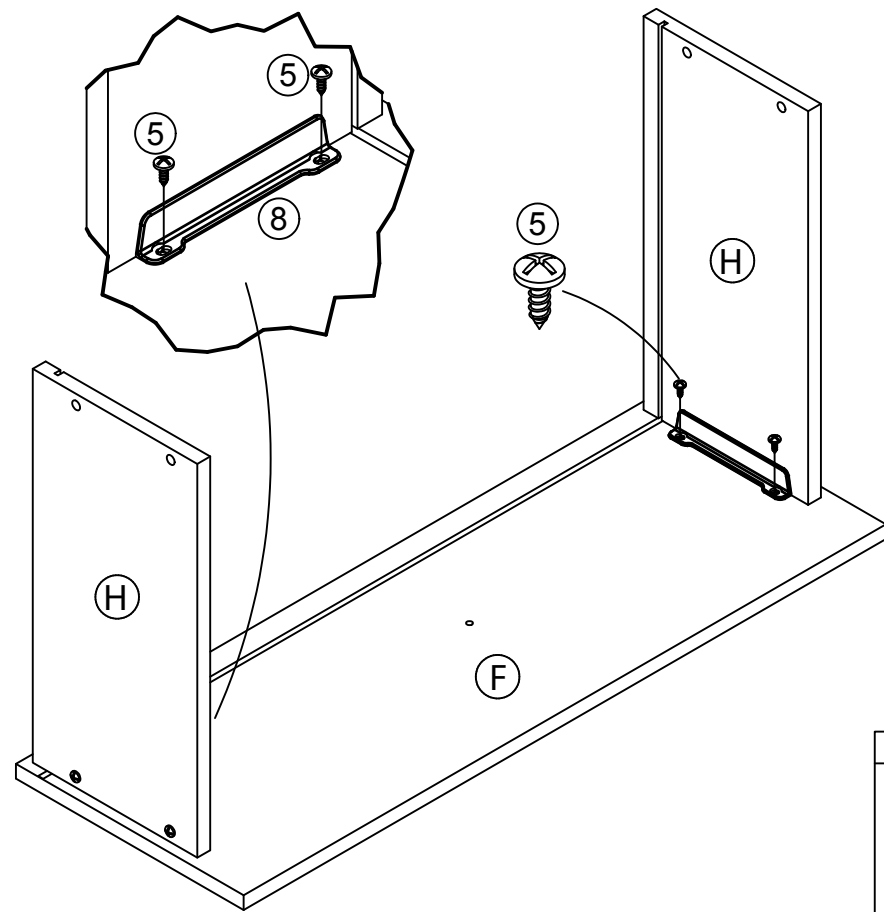

5

PAN HEAD SCREW 4 PCS

TOOL REQUIRED

# STEP 8

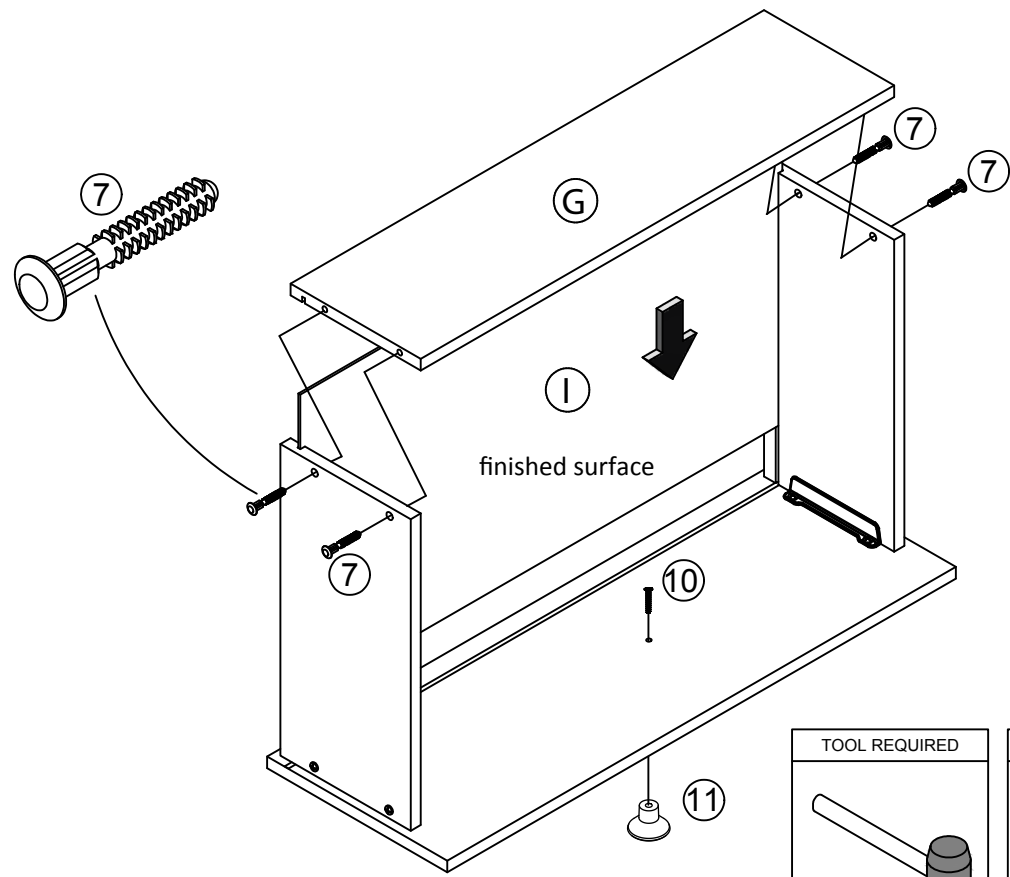

10

HANDLE SCREW 1 PC

11

HANDLE KNOB 1 PC

7

DRIVER FASTENER 4 PCS

TOOL REQUIRED

TOOL REQUIRED

# STEP 1

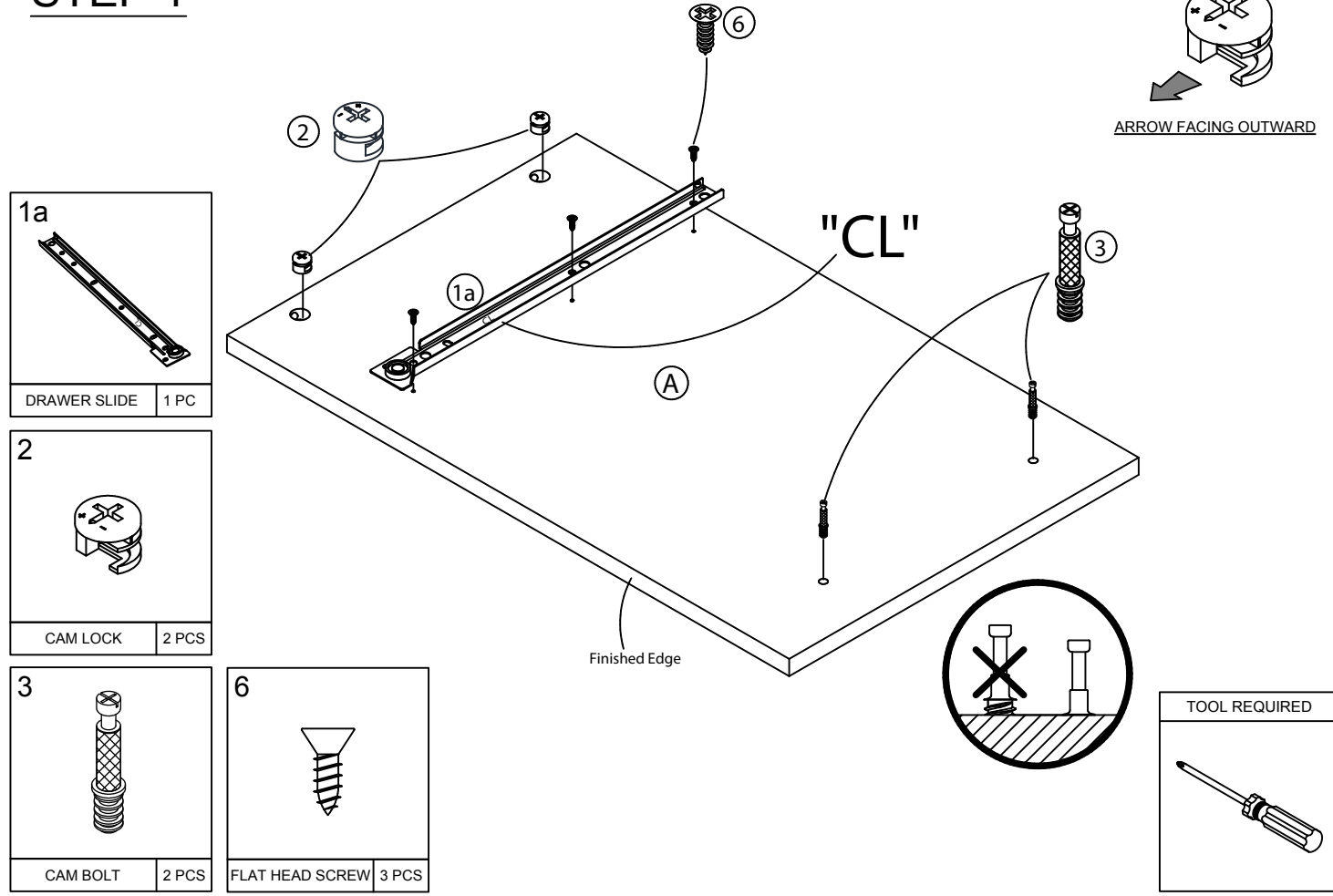

1a

DRAWER SLIDE 1 PC

2

CAM LOCK 2 PCS

3

CAM BOLT 2 PCS

6

FLAT HEAD SCREW 3 PCS

ARROW FACING OUTWARD

TOOL REQUIRED

# STEP 2

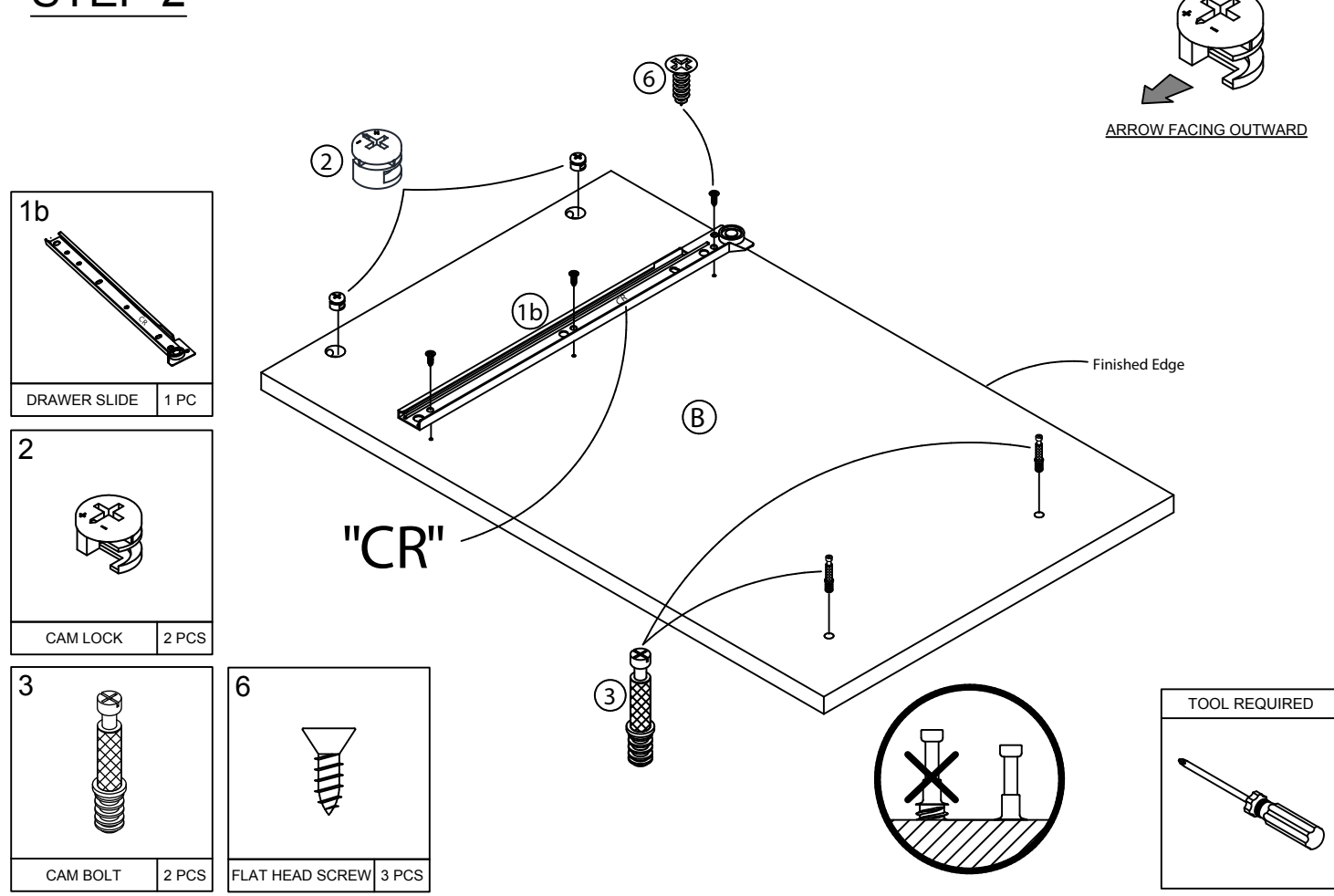

1b

DRAWER SLIDE 1 PC

2

CAM LOCK 2 PCS

3

CAM BOLT 2 PCS

6

FLAT HEAD SCREW 3 PCS

ARROW FACING OUTWARD

TOOL REQUIRED

### STEP 3

STEP 3.1

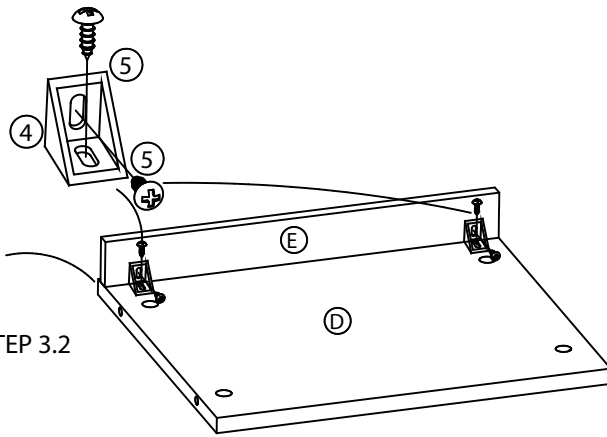
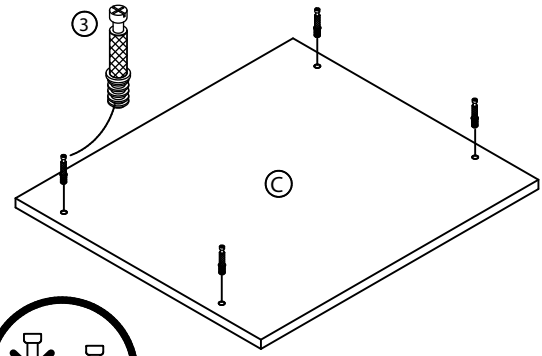

STEP 3.3

Finished Edge

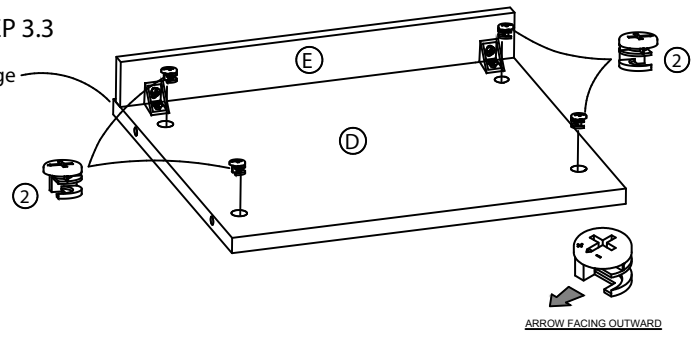

TOOL REQUIRED

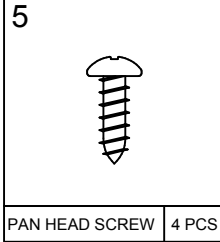
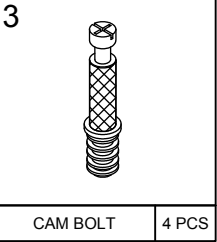
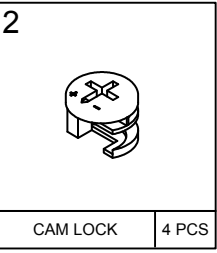
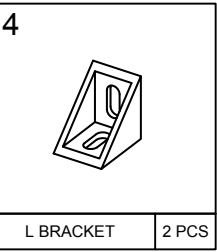
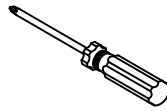

### STEP 4

STEP 4.2

Finished Edge

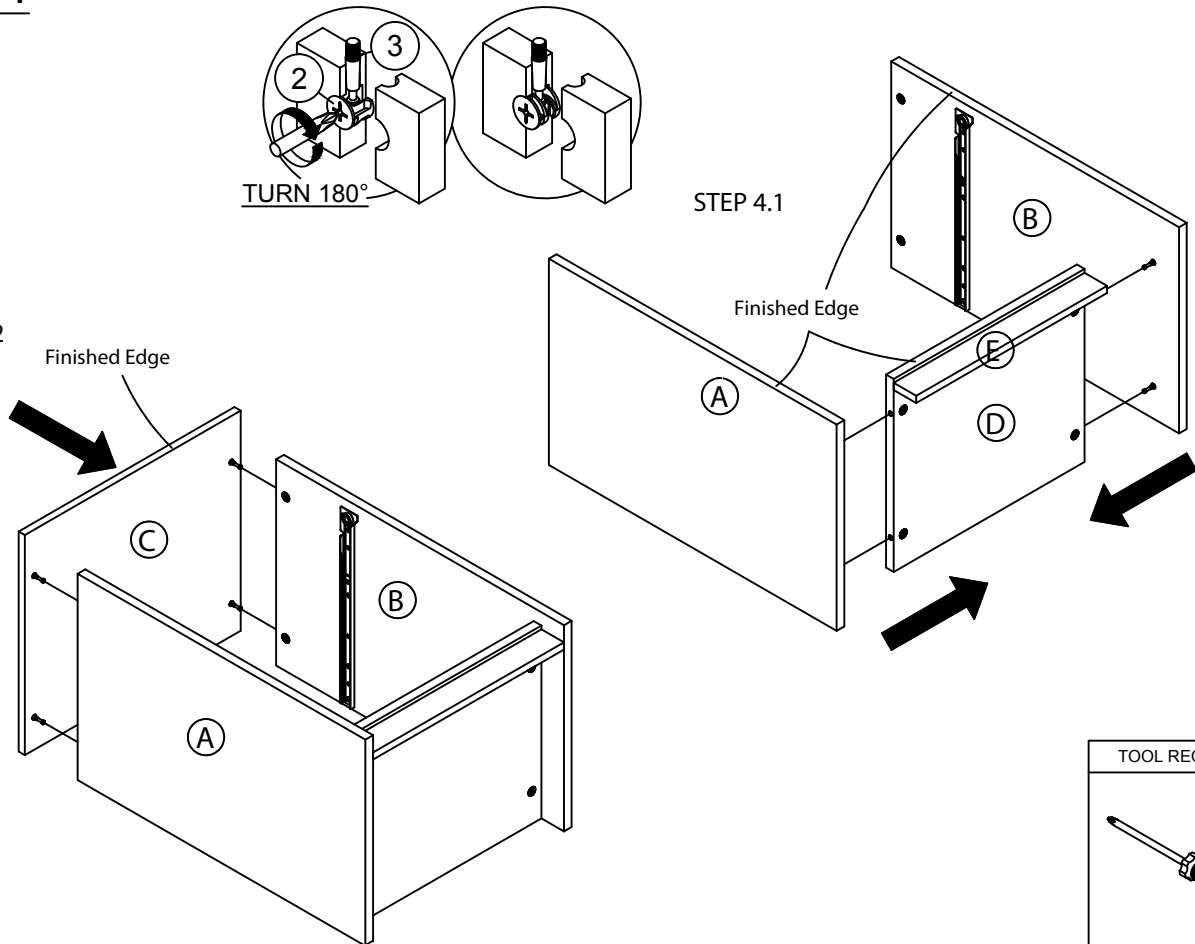

STEP 4.1

Finished Edge

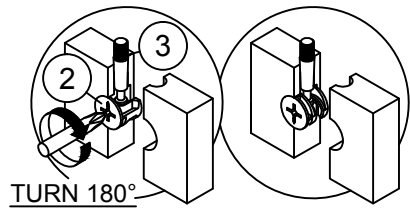

TOOL REQUIRED

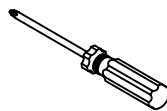

### STEP 5

TURN 180°

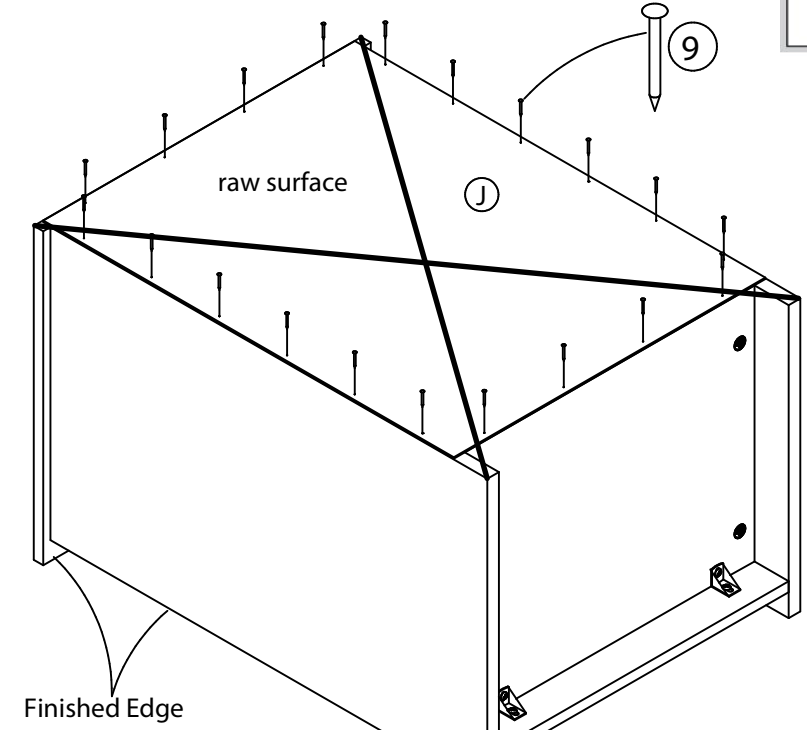
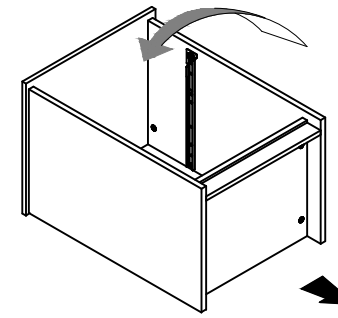

**WARNING**

WATCH YOUR HANDS AND FINGERS



TOOL REQUIRED

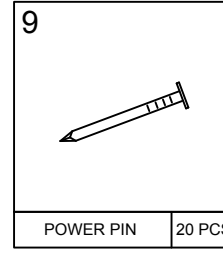
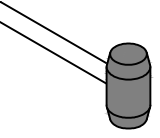

### STEP 6

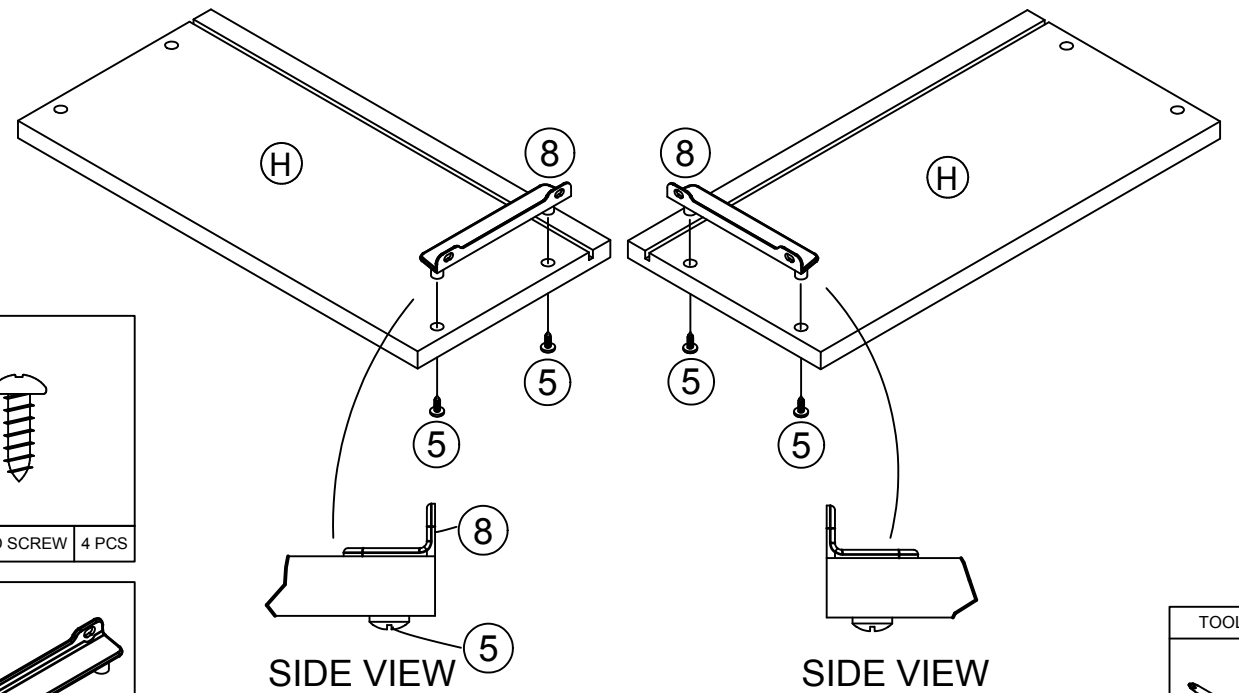
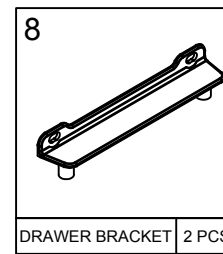
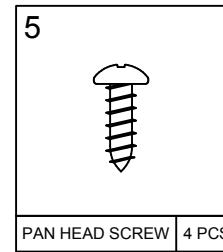

TOOL REQUIRED

